

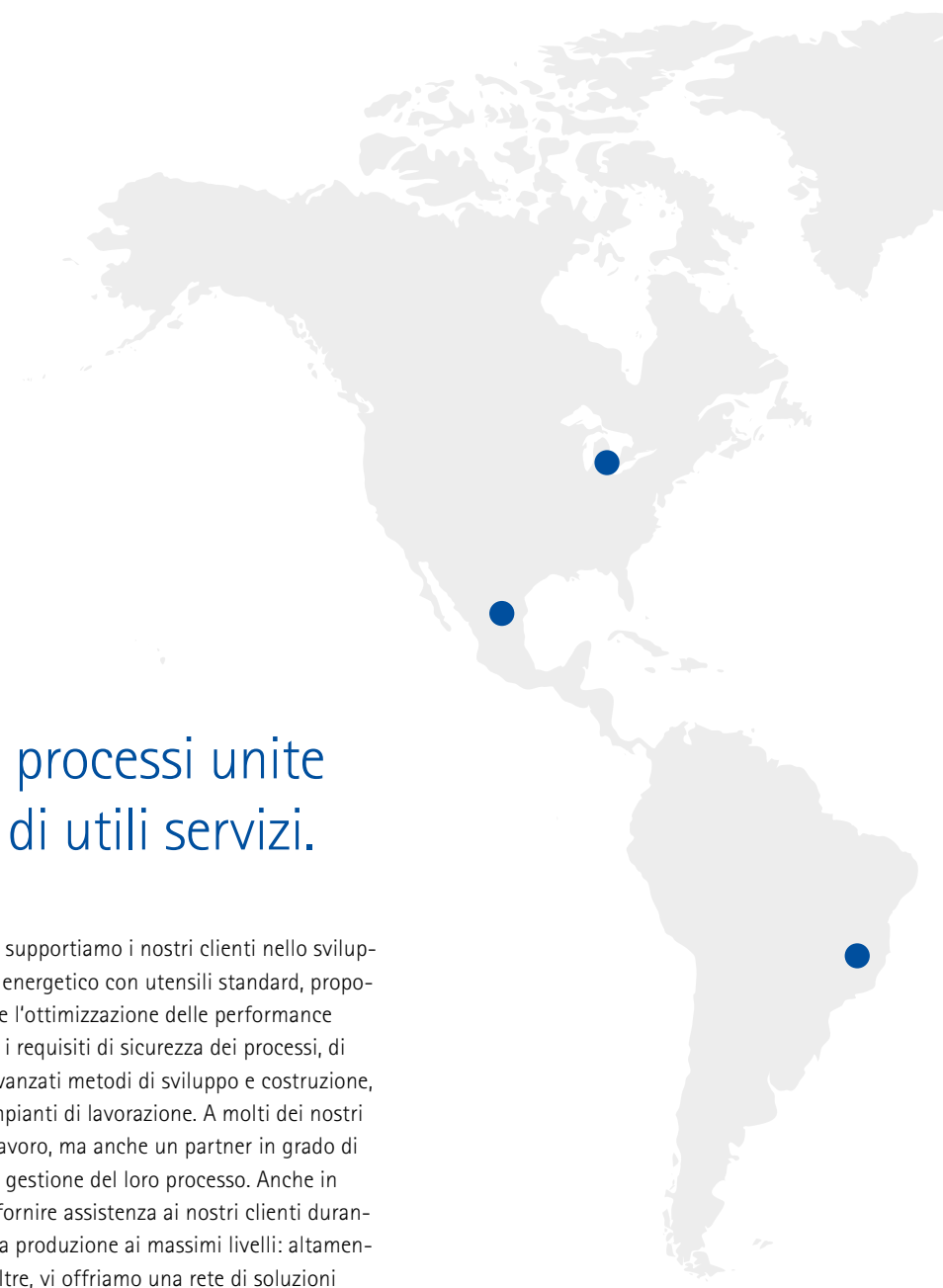

Il Vostro partner tecnologico per l'asportazione truciolo

LAVORAZIONE DI FORI



Soluzioni di utensili e processi unite ad una vasta gamma di utili servizi.

Ci riteniamo un partner tecnologico di alto livello, e supportiamo i nostri clienti nello sviluppo di processi di produzione efficienti e a risparmio energetico con utensili standard, proponendo anche soluzioni personalizzate degli utensili e l'ottimizzazione delle performance dell'utensile stesso. I nostri utensili soddisfano tutti i requisiti di sicurezza dei processi, di precisione e di facilità d'utilizzo. Come? Grazie ad avanzati metodi di sviluppo e costruzione, nonché a una produzione dotata dei più moderni impianti di lavorazione. A molti dei nostri clienti non serve solo l'utensile ottimale per il loro lavoro, ma anche un partner in grado di assumersi l'incarico dell'intera progettazione e della gestione del loro processo. Anche in questo caso siamo a Vostra disposizione. Possiamo fornire assistenza ai nostri clienti durante tutte le fasi di produzione e manteniamo la vostra produzione ai massimi livelli: altamente produttiva, conveniente e con processi sicuri. Inoltre, vi offriamo una rete di soluzioni complete per tutti i servizi che fanno da corollario al vero e proprio processo di lavorazione.

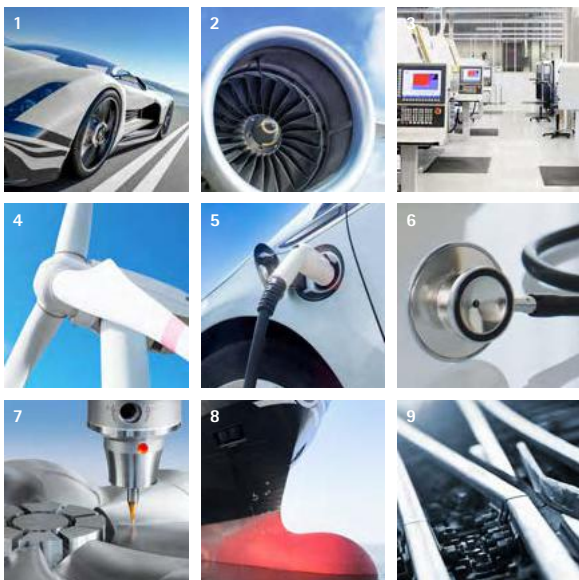

Settori

- 1 Settore automobilistico
- 2 Ingegneria aerospaziale
- 3 Ingegneria meccanica
- 4 Produzione di energia
- 5 Mobilità elettrica
- 6 Ingegneria medica
- 7 Costruzione di stampi e matrici
- 8 Costruzione navale
- 9 Trasporto ferroviario

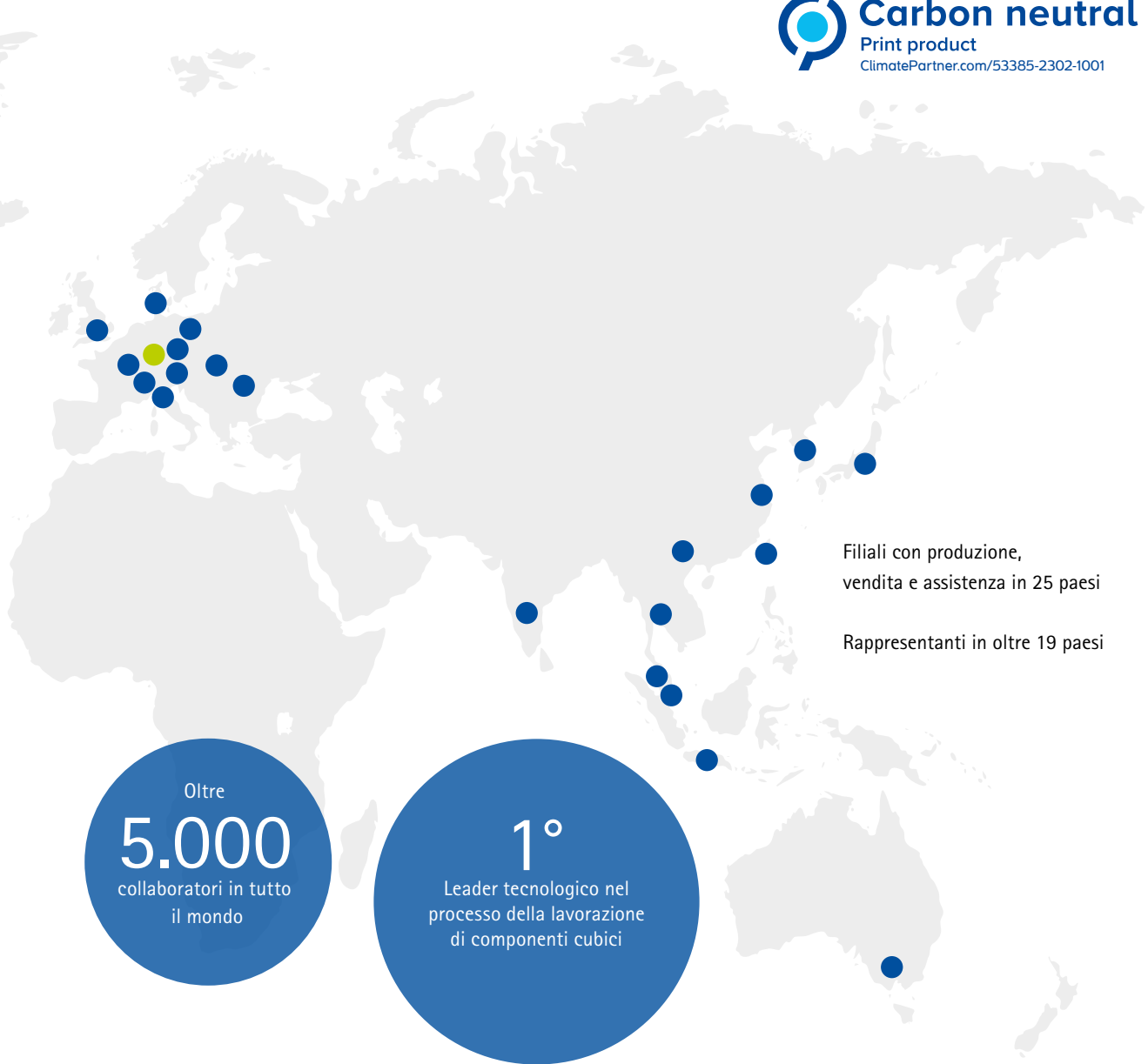

Oltre
5.000
collaboratori in tutto
il mondo

1°
Leader tecnologico nel
processo della lavorazione
di componenti cubici



Campi di applicazione del prodotto

- 1 Alesatura e barenatura di precisione
- 2 Foratura, barenatura e svasatura
- 3 Fresatura
- 4 Tornitura
- 5 Utensili a movimentazione interna
- 6 Sistemi di serraggio
- 7 Presettaggio, misurazione e stoccaggio
- 8 Servizi



INDICE

01 Introduzione

Competenza nella lavorazione di fori	6
Panoramica prodotti	8

02 Foratura

Panoramica prodotti, panoramica serie, guida per la selezione, codice di denominazione ..	12
Foratura	
Utensili di foratura in metallo duro integrale	29
Utensili di foratura a fissaggio meccanico	183
Foratura con inserti a fissaggio meccanico	239
Foratura pilota	245
Foratura a gradino	257
Foratura profonda	267
Foratura-alesatura	289
Soluzioni speciali	300

03 Alesatura e barenatura di precisione

Panoramica prodotti	306
Alesatori fissi a più taglienti	311
Utensili con pattini di guida	477
Soluzioni per grandi diametri	560
Soluzioni speciali	572

04 Svasatura

Utensili di svasatura	585
-----------------------------	-----

05 Barenatura e tornitura

Panoramica prodotti	596
Soluzioni speciali	598
ModulBore	613
Cartucce	643
Inserti a fissaggio meccanico	663

06 Allegato tecnico

Allegato tecnico	737
------------------------	-----

COMPETENZA NELLA LAVORAZIONE DI FORI

L'utensile ottimale per ogni applicazione

Partendo da una produzione incentrata su strumenti personalizzati volti a realizzare soluzioni di lavorazione specifiche per il cliente, MAPAL ha sviluppato un vasto assortimento standard per la lavorazione di fori.

MAPAL è uno dei maggiori offerenti, a livello mondiale, di utensili in metallo duro integrale nel campo della foratura. L'assortimento di punte in metallo duro integrale comprende soluzioni per la lavorazione sicura e conveniente di pressoché qualsiasi materiale, ed è completato da moderni sistemi a testina intercambiabile per la massima redditività.

Per la lavorazione fine di fori sono disponibili alesatori fissi a più taglienti, utensili con pattini di guida, alesatori monotagliente, il sistema EasyAdjust (sistema EA), inserti a fissaggio meccanico con affilatura di precisione e soluzioni per grandi diametri fino a 400 mm.

Gli utensili con inserti a fissaggio meccanico svolgono un ruolo di primo piano nel campo della barenatura. Particolarmente convenienti sono gli inserti a fissaggio meccanico positivi radiali per barenatura e tornitura. Per le operazioni di barenatura più complesse sono invece disponibili inserti a fissaggio tangenziale.



Foratura



MAPAL propone un vasto assortimento standard di punte in metallo duro integrale per tutte le operazioni di lavorazione. Accanto a utensili a due e tre taglienti per la foratura, sono disponibili anche punte pilota, punte a gradino, punte per foratura profonda nonché foratori-alesatori per foratura e alesatura in un'unica fase di lavorazione. La gamma comprende inoltre punte in metallo duro integrale con sistema a testina intercambiabile e inserti a fissaggio meccanico.

Che si tratti di ghisa, metalli non ferrosi, acciaio, moderni materiali per costruzioni leggere o di difficile lavorazione, MAPAL offre la punta più adatta per qualsiasi tipo di materiale.

Alesatura e barenatura di precisione



L'alesatura e la barenatura di precisione sono i processi più comunemente utilizzati nella lavorazione fine di fori, e convincono grazie ai risultati particolarmente precisi. A seconda della complessità della lavorazione e dei requisiti in termini di precisione e superficie, MAPAL offre sempre la soluzione più adatta.

Gli alesatori fissi a più taglienti consentono elevati avanzamenti e riducono notevolmente i tempi di lavorazione. L'assortimento include alesatori monoblocco in metallo duro, cermet o HSS, nonché alesatori a testina intercambiabile HPR con attacco HFS ad alta precisione. Per la lavorazione di grandi diametri fino a 400 mm è disponibile un programma HPR modulare.

Gli utensili con pattini di guida sono garanzia di massima precisione. Oltre ad alesatori monotagliente, fanno parte dell'assortimento standard il sistema EasyAdjust per un presettaggio degli utensili facile e veloce, così come inserti a fissaggio meccanico con affilatura di precisione.

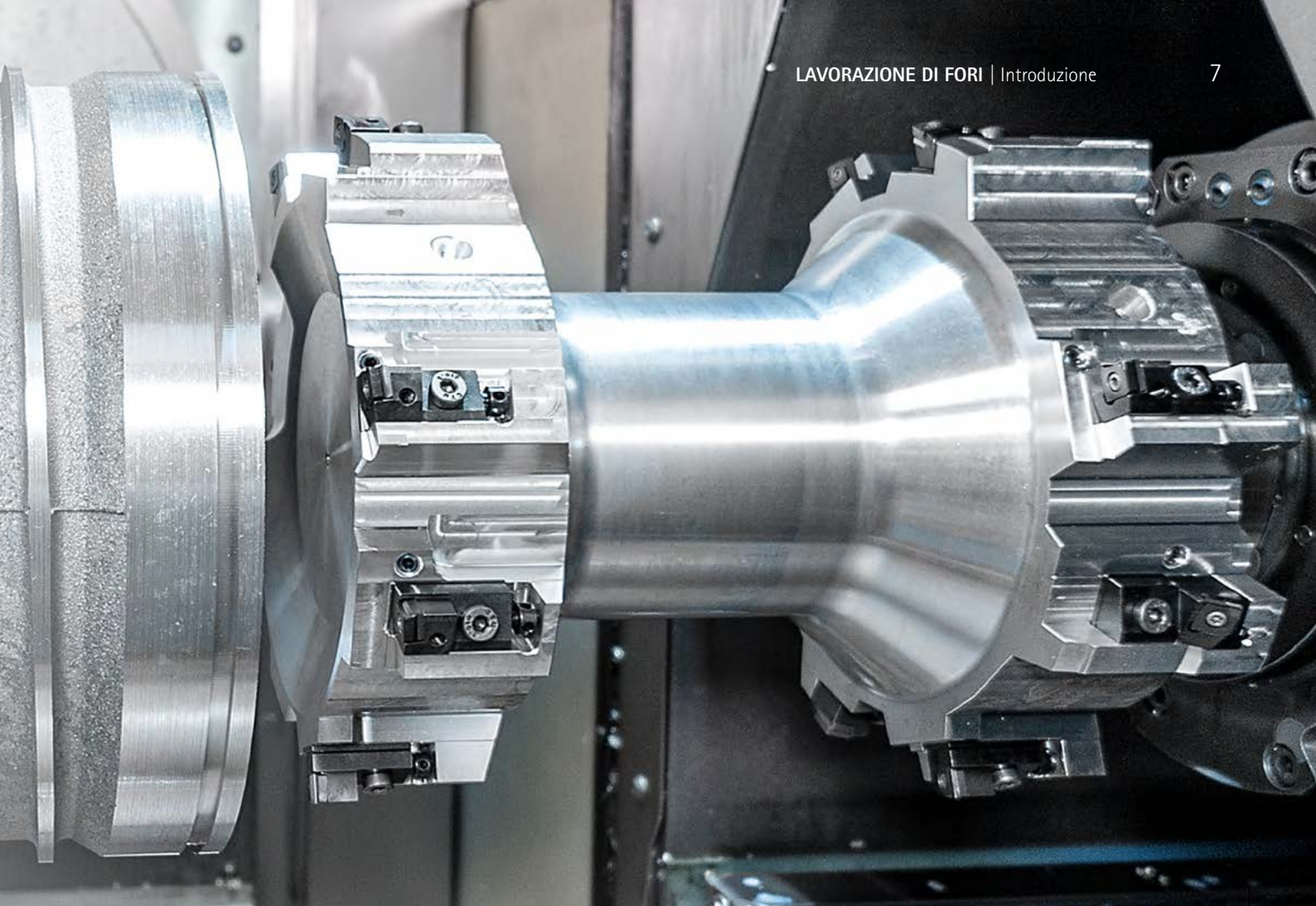

Svasatura



Gli utensili di svasatura a passo estremamente differenziato targati MAPAL hanno segnato nuovi traguardi nel campo della svasatura. Disponibili in versione HSS e in metallo duro integrale, lavorano con forze assiali e radiali sensibilmente ridotte rispetto ai comuni utensili di svasatura. I vantaggi sono evidenti: essi consentono infatti non solo di ottenere una migliore qualità superficiale, ma garantiscono anche un'elevata durata utile degli utensili ed eccellenti collegamenti per viti e rivetti.

Barenatura e tornitura



MAPAL offre diverse idee e soluzioni di utensile per barenatura e tornitura. Progettate per soddisfare svariati requisiti, assicurano flessibilità, redditività e sicurezza dei processi anche nelle applicazioni più complesse. L'assortimento include tra l'altro cartucce, inserti a fissaggio meccanico di tipo radiale e tangenziale, soluzioni personalizzate con inserti a fissaggio meccanico o taglienti in PCD e la gamma per barenatura ModulBore, prodotta specificamente in base alle esigenze dei clienti.

PANORAMICA PRODOTTI



1 | Foratura

- 1.1** Utensili di foratura in metallo duro integrale (da pagina 29)
- 1.2** Utensili di foratura a fissaggio meccanico (da pagina 183)
 - Foratura con inserti a fissaggio meccanico (da pagina 239)
- 1.3** Foratura pilota (da pagina 245)
- 1.4** Foratura a gradino (da pagina 257)
- 1.5** Foratura profonda (da pagina 267)
- 1.6** Foratura-alesatura (da pagina 289)

2 | Alesatura e barenatura di precisione

- 2.1** Alesatore ad alte prestazioni | FXR (da pagina 316)
- 2.2** Alesatore a testina intercambiabile | HPR (da pagina 368)
 - Alesatori ad alte prestazioni con rivestimento | MOR/MRF (da pagina 350)
- 2.3** Alesatore monotagliante (da pagina 478)
- 2.4** Sistema EasyAdjust (da pagina 514)
- 2.5** Soluzioni per grandi diametri (da pagina 560)



3 | Svasatura

3.1 Utensili di svasatura (da pagina 586)

4 | Barenatura e tornitura

4.1 Soluzioni speciali con PCD (da pagina 598)

4.2 Soluzioni speciali con inserti a fissaggio meccanico (da pagina 604)

4.3 ModulBore (da pagina 613)

4.4 Cartucce (da pagina 643)

4.5 Inserti a fissaggio meccanico (da pagina 663)

FORATURA

Punte ottimali per pressoché qualsiasi applicazione e materiale.





PANORAMICA PRODOTTI

Per la foratura, MAPAL propone un vasto assortimento standard per pressoché tutte le operazioni di lavorazione, composto sia da punte in metallo duro integrale che da punte ad inserto intercambiabile. L'assortimento comprende punte universali così come utensili per la lavorazione di ghisa, metalli non ferrosi, acciai, materiali per costruzioni leggere e materiali di difficile lavorazione ad asportazione truciolo. Fanno inoltre parte dell'offerta speciali soluzioni a tre taglienti per la lavorazione ad alta velocità e ad alto avanzamento.

Per soddisfare anche le esigenze più specifiche, MAPAL propone punte personalizzate con riporto in PCD. Allo stesso modo, è altresì possibile realizzare punte in metallo duro integrale su misura capaci di rispondere ai singoli requisiti imposti dal cliente. Attivo su scala mondiale, il servizio di riaffilatura garantisce per tutti gli utensili una qualità pari all'originale e massima redditività.



Basic Line:
utensili universali, vasto campo di applicazione, bassi costi di acquisto





Performance Line:
utensili ad alte prestazioni, vasto campo di applicazione, elevata produttività nella produzione di serie



Expert Line:
utensili specifici per le applicazioni selezionate, massima precisione e massima produttività

Punta in metallo duro integrale			Punta pilota
			
<p>Utensili di foratura in metallo duro integrale</p> <p>Punta in metallo duro integrale per pressoché qualsiasi materiale in tre diverse tipologie di prestazione.</p> <ul style="list-style-type: none"> - MEGA-Drill - Punta in metallo duro integrale a due taglienti con rivestimento e geometria ottimali per la lavorazione di qualsiasi materiale - Tritan-Drill - Punta in metallo duro integrale per massimo avanzamento con tagliente trasversale autocentrante per situazioni di foratura difficili - ECU-Drill - Assortimento selezionato estremamente conveniente con un ottimo rapporto qualità prezzo <p>Range di \varnothing: 0,50 - 25,00 mm Profondità di foratura: 3xD 4xD 5xD 6xD 8xD 12xD</p> <p>P M K N C S H</p>	<p>Utensili di foratura a fissaggio meccanico</p> <p>Foratura con impiego di metallo duro ridotto al minimo in condizioni di massima stabilità e precisione.</p> <ul style="list-style-type: none"> - Punta con inserto QTD - Sistema conveniente con inserti intercambiabili - Punta ad inserto intercambiabile TTD - Punta ad inserto intercambiabile a due taglienti con cinque diverse testine di foratura - Punta ad inserto intercambiabile TTD-Tritan - Avanzamento maggiore fino al doppio rispetto alle punte ad inserto intercambiabile a due taglienti. Elevata sicurezza dei processi e stabilità anche in situazioni di foratura difficili <p>Range di \varnothing: 9,00 - 50,00 mm Profondità di foratura: 1xD 1,5xD 3xD 5xD</p> <p>P M K N C S H</p>	<p>Utensili di foratura con inserti a fissaggio meccanico</p> <p>Utensili di foratura in alluminio con inserti a fissaggio meccanico con rivestimento diamantato CVD.</p> <ul style="list-style-type: none"> - Inserti a fissaggio meccanico a tre taglienti con rivestimento diamantato CVD per la massima produttività e redditività - Foratura da AISi1 fino a AISi12 - Con adduzione interna del refrigerante, possibilità anche di lubrificazione miniale - Soluzioni su misura per: \varnothing 16 - 54,9 mm <p>Range di \varnothing: 16,00 - 54,90 mm Profondità di foratura: Fino a 3xD</p> <p>N</p>	<p>Foratura pilota</p> <p>Esecuzione di fori di centraggio secondo DIN.</p> <ul style="list-style-type: none"> - Tritan-Spot-Drill - Punta pilota a tre taglienti per situazioni di foratura impegnative, pensata specificamente per punte tre taglienti - ECU-Centre-Drill - Realizzazione di fori di centraggio secondo DIN in componenti con rotazione simmetrica - CPD-Spot-Drill - Punta a centrare a due taglienti con attacco CFS <p>Range di \varnothing: 0,50 - 20,00 mm</p> <p>P M K S</p>
Pagina 29	Pagina 183	Pagina 239	Pagina 245

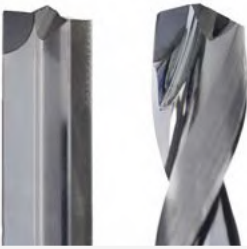

Punta a gradino	Punta per foratura profonda	Foratore-alesatore	Soluzioni speciali
			
<p>Foratura a gradino</p> <p>Realizzazione di prefori e smussature di filettature metriche.</p> <ul style="list-style-type: none"> - Tritan-Step-Drill - Punta a gradino a tre taglienti con tagliente trasversale autocentrante per la lavorazione i fori da maschiare senza movimenti oscillatori - MEGA-Step-Drill - Punta a gradino a due taglienti per la realizzazione di fori da maschiare <p>Range di \varnothing: 2,50 - 17,50 mm</p> <p>P M</p>	<p>Foratura profonda</p> <p>Efficiente realizzazione di fori profondi fino a 40xD, nella totale sicurezza dei processi.</p> <ul style="list-style-type: none"> - MEGA-Deep-Drill - Punta per foratura profonda con adduzione interna del refrigerante per la lavorazione in totale sicurezza dei processi di fori profondi fino a 40xD - MEGA-Pilot-Drill - Punta pilota specifica per MEGA-Deep-Drill <p>Range di \varnothing: 1,00 - 16,00 mm</p> <p>Profondità di foratura:</p> <p>12xD 20xD 25xD 30xD 40xD</p> <p>P M K N</p>	<p>Foratura-alesatura</p> <p>Foratura e alesatura in un'unica fase di lavoro.</p> <p>Tritan-Drill-Reamer:</p> <ul style="list-style-type: none"> - Soluzione più precisa per foratura-alesatura - Tre taglienti e sei margini di guida - Tagliente trasversale autocentrante per un migliore centraggio - Alta precisione di posizionamento - Ottima circolarità - Con adduzione interna del refrigerante - Versioni tolleranza $\pm 0,003$ mm e H7 <p>Range di \varnothing: 3,80 - 20,05 mm</p> <p>Profondità di foratura:</p> <p>3xD 5xD</p> <p>P K N</p>	<p>Soluzioni speciali</p> <ul style="list-style-type: none"> - Soluzioni speciali specifiche per l'applicazione nel settore delle punte in metallo duro integrale - Punte con riporto in PCD appositamente progettate per la lavorazione specifica di alluminio e CFRP - L'assortimento include semplici punte a scanalatura dritta con riporto in PCD fino a punte elicoidali a gradino con riporto in PCD - Centro di competenza leader a livello mondiale per utensili in PCD con sede a Pforzheim
Pagina 257	Pagina 267	Pagina 289	Pagina 300

PANORAMICA SERIE

Utensili di foratura in metallo duro integrale

PUNTE MEGA

Punte in metallo duro integrale a due taglienti con rivestimento e geometria ottimali per la lavorazione di qualsiasi materiale.



MEGA-Drill

- Rivestimento e geometria studiati appositamente in base al materiale
- Vasto campo di applicazioni
- Contiene punta per foratura profonda, punta a gradini e micropunta per qualsiasi applicazione

Classe di prodotto: Idoneità del materiale: Profondità di foratura:

Perfor
ance
LINE

P M K
N C S H

3xD 4xD
5xD 8xD 12xD

Range di ϕ : 0,50 - 25,00 mm



MEGA-Speed-Drill

- Punta ad elevata velocità con due taglienti
- Profilo della scanalatura sottoposto a finissima levigatura per una rapida asportazione dei trucioli
- Tre margini di guida riducono l'attrito e le vibrazioni

Classe di prodotto: Idoneità del materiale: Profondità di foratura:

Expert
LINE

P M
K S

3xD 8xD
8xD 12xD

Range di ϕ : 3,00 - 20,00 mm



MEGA-Quadro-Drill

- Quattro margini di guida per massimizzare la qualità del foro, la coassialità e la precisione di posizionamento
- Ottima circolarità e tolleranze diametro

Classe di prodotto: Idoneità del materiale: Profondità di foratura:

Perfor
ance
LINE

P
K

5xD
8xD 12xD

Range di ϕ : 3,00 - 20,00 mm



MEGA-180°-Drill

- Foratura a fondo piatto
- Foratura pilota su superfici inclinate fino a 45°

Classe di prodotto: Idoneità del materiale: Profondità di foratura:

Expert
LINE

P M
K N

3xD
5xD

Range di ϕ : 3,00 - 20,00 mm



PUNTA TRITAN

Punte in metallo duro integrale per massimo avanzamento con tagliente trasversale autocentrante per situazioni di foratura difficili.



PUNTA ECU

Assortimento selezionato estremamente conveniente con un ottimo rapporto qualità prezzo.



Tritan-Drill

- Utensili robusti con angoli del tagliente molto stabili
- Nessun movimento oscillatorio in fase di lavorazione
- Asportazione dei trucioli ottimale



Classe di prodotto:



Idoneità del materiale:



Profondità di foratura:

3xD	8xD
8xD	12xD

Range di ϕ : 4,00 - 20,00 mm

ECU-Drill

- Assortimento selezionato conveniente
- Materiale da taglio e rivestimenti specifici per materiale in lavorazione



Classe di prodotto:



Idoneità del materiale:



Profondità di foratura:









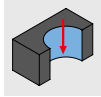
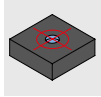

3xD	5xD
8xD	12xD

Range di ϕ : 3,00 - 20,00 mm

COME SCEGLIERE UNA PUNTA

Passo dopo passo verso la punta giusta

Siete alla ricerca, ad esempio, di una punta integrale per la lavorazione dell'acciaio temprato? La presente guida per la selezione vi condurrà passo dopo passo alla punta giusta.

1	Applicazione	Selezionate la vostra applicazione principale.	>	 Foratura	 Foratura pilota
2	Design	Selezionate la versione dell'utensile che preferite.	>	 Monolitico	 Innesto QTS
3	Classe di prodotto	Scegliete una classe di prodotto.	>	 Basic LINE	Basic Line: utensili universali, vasto campo di applicazione, bassi costi di acquisto
4	Idoneità del materiale	Selezionate il materiale dei pezzi da lavorare secondo i gruppi di materiale MAPAL (GTM). I GTM sono riportati sulla pagina pieghevole alla fine del catalogo.	>	 P Acciaio	 M Acciaio inossidabile
5	Caratteristiche del componente	Verificate i requisiti che l'utensile deve soddisfare attraverso le caratteristiche di foratura.	>	 HFC Lavorazione ad alto avanzamento	 HSC Lavorazione ad alta velocità
			>	 IT7 Tolleranza di foratura raggiungibile \geq IT	 H7 Serie selezionata in H7
6	Versione	Assicuratevi che le caratteristiche della geometria corrispondano ai vostri requisiti.	>	Range di diametro	Numero di taglianti
7	Prodotto	Selezionate la vostra punta. I prodotti della serie selezionata per il magazzino sono disponibili con un breve preavviso, mentre i prodotti con caratteristiche configurabili sono liberamente configurabili entro limiti predefiniti.	>		Serie selezionata per il magazzino



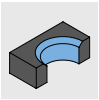

Foratura a gradino

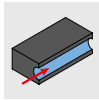

Foratura profonda

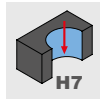

Foratura-alesatura



Attacco TTS



Attacco CFS



Con inserto a fissaggio meccanico



Performance Line: utensili ad alte prestazioni, vasto campo di applicazione, elevata produttività nella produzione di serie



Expert Line: utensili specifici per le applicazioni selezionate, massima precisione e massima produttività



Ghisa



Metalli non ferrosi e materiali sintetici

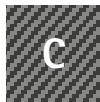

Materiali composti



Superleghe e titanio



Acciaio temprato e acciaio fuso

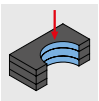

Foratura a pacco

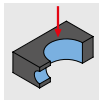

Foratura trasversale

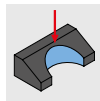

Ingresso inclinato del foro

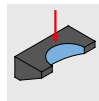

Uscita inclinata del foro

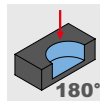

Fondo di foratura piano 180°



Tolleranza diametro di affilatura utensile



Profondità di foratura massima

Numero margini di guida



Adduzione del refrigerante



Prodotto con caratteristiche configurabili

BORE MACHINING | Drilling from solid 19

Step 1: Application Step 2: Design Step 3: Product category Step 4: Material suitability Step 5: Part features Step 6: Design

Design				Product			
ø [mm]	z	ngc*		Product name	Specification		Page
3 - 25	2	2	✓	MEGA-Drill-Steel-Plus	SCD600, 601		51
2 - 20	2	2	✓	MEGA-Drill-Inox	SCD120, 121		129
2,8 - 20	2	2	✓	MEGA-Drill-Alu	SCD131		151
2,55 - 20	2	2	✓	MEGA-Drill-Hardened	SCD140		82
0,5 - 12	2	2		MEGA-Drill-Composite-IMD	SCD250		156
0,8 - 2,99	2	2	✓	MICRO-Drill-Steel	SCD371		79

6 → **7** →



Foratura (1/2)

Design	Classe di prodotto	Idoneità del materiale						Caratteristica di foratura							Profondità di foratura											
		P	M	K	N	C	S	H	HFC	HSC	180°	Tolleranza	3xD	4xD	5xD	6xD	8xD	12xD								
Performance LINE	Performance LINE	■		■				■				✓	✓					IT9	✓		✓					
		■	■	■	■		■												IT9	✓		✓				
					■															IT9	✓		✓		✓	
									■											IT9		✓				
				■		■	■													IT9			✓		✓	✓
				■		■										✓				IT9			✓		✓	✓
																				IT9						
Expert LINE	Expert LINE	■	■	■	■				✓		✓	✓	✓	✓				IT9			✓		✓	✓		
		■	■	■					✓		✓	✓	✓	✓				IT9	✓		✓		✓	✓		
		■	■	■						✓									IT9	✓		✓		✓		
		■	■	■						✓									IT9	✓		✓		✓	✓	
		■	■				■			✓									IT9			✓		✓	✓	
				■						✓									IT9			✓				
		■	■	■											✓				IT9	✓		✓				
					■											✓			IT9	✓		✓				
						■													IT9			✓				
				■	■	■													IT9		✓		✓			
Basic LINE	Basic LINE	■	■	■														IT9		✓		✓				
		■		■															IT9	✓		✓		✓	✓	
				■	■														IT9			✓		✓		

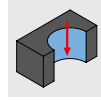
Fase 1:
ApplicazioneFase 2:
DesignFase 3:
Classe di prodottoFase 4:
Idoneità del materialeFase 5:
Caratteristiche del com-
ponenteFase 6:
Versione

	Versione				Prodotto			
	ø [mm]	z	n _{FF} *		Nome del prodotto	Specifiche		Pagina
	3 - 25	2	2	✓	MEGA-Drill-Steel-Plus	SCD600, 601		51
	2 - 20	2	2	✓	MEGA-Drill-Inox	SCD120, 121		129
	2,8 - 20	2	2	✓	MEGA-Drill-Alu	SCD131		151
	2,55 - 20	2	2		MEGA-Drill-Hardened	SCD140		82
	0,5 - 12	2	2		MEGA-Drill-Composite-MD	SCD250		156
	0,8 - 2,99	2	2	✓	MICRO-Drill-Steel	SCD371		79
	3 - 20	2	4	✓	MEGA-Quadro-Drill-Plus	SCD610, 611		70
	4 - 20	3	3	✓	Tritan-Drill-Uni-Plus	SCD631		30
	4 - 20	3	3	✓	Tritan-Drill-Steel	SCD661		85
	3 - 20	2	3	✓	MEGA-Speed-Drill-Uni	SCD221		36
	3 - 20	2	3	✓	MEGA-Speed-Drill-Steel	SCD621		95
	3 - 20	2	3	✓	MEGA-Speed-Drill-Inox	SCD411		142
	3 - 20	2	3	✓	MEGA-Speed-Drill-Iron	SCD421		150
	3 - 20	2	4	✓	MEGA-180°-Drill	SCD231		105
	3 - 20	2	4	✓	MEGA-180°-Drill-Alu	SCD241		160
	3 - 12	2	2		MEGA-Drill-Composite-UDX	SCD270, 271		158
	3 - 20	2	2	✓	ECU-Drill-Uni	SCD350, 351		42
	3 - 20	2	2	✓	ECU-Drill-Steel	SCD360, 361		111
	4,8 - 11,6	2	4	✓	ECU-G-Drill	SCD211		164

* n_{FF} = numero dei margini di guida

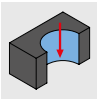

Foratura (2/2)

Design	Classe di prodotto	Idoneità del materiale						Caratteristica di foratura							Profondità di foratura												
		P	M	K	N	C	S	H	HFC	HSC							Tolleranza	1xD	1,5xD	3xD		5xD	8xD	12xD			
	Performance LINE	■		■														IT9	✓		✓	✓	✓	✓			
		■		■															IT9	✓		✓	✓	✓	✓		
		■	■	■	■			■											IT9	✓		✓	✓	✓	✓		
					■															IT9	✓		✓	✓	✓	✓	
						■														IT9	✓		✓	✓	✓	✓	
	Expert LINE	■		■					✓		✓	✓	✓	✓				IT9			✓	✓	✓				
		■		■															IT10		✓	✓	✓	✓	✓		
		■		■															IT10		✓	✓	✓	✓	✓		
		■	■	■															IT10		✓	✓	✓	✓	✓		
					■															IT10		✓	✓	✓	✓	✓	
						■														IT10		✓	✓	✓	✓	✓	
	Performance LINE	■		■														IT10		✓	✓	✓	✓	✓			
		■		■															IT10		✓	✓	✓	✓	✓		
	Performance LINE	■	■	■														IT9	✓	✓	✓						
		■		■															IT9	✓	✓	✓					

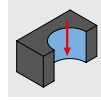
Fase 1:
ApplicazioneFase 2:
DesignFase 3:
Classe di prodottoFase 4:
Idoneità del materialeFase 5:
Caratteristiche del com-
ponenteFase 6:
Versione

	Versione				Prodotto			
	ø [mm]	z	n _{FF} *		Nome del prodotto	Specifiche		Pagina
	12 - 45	2	4	✓	Testina di foratura intercambiabile TTD Uni-Plus	01P-Uni-Plus		206
	12 - 45	2	3	✓	Testina di foratura intercambiabile TTD Steel	04-Steel		207
	12 - 45	2	3	✓	Testina di foratura intercambiabile TTD Inox	02-Inox		209
	12 - 45	2	4	✓	Testina di foratura intercambiabile TTD Iron	05-Iron		211
	12 - 45	2	4	✓	Testina di foratura intercambiabile TTD Alu	03-Alu		212
	12 - 32,49	3	3	✓	Testina di foratura intercambiabile TTD-Tritan Uni	01-Uni		230
	9 - 50	2	2	✓	Inserito QTD Steel	01-Steel		186
	14 - 32	2	2	✓	Inserito QTD Steel-Pyramid	05-Pyramid		188
	10 - 33	2	2	✓	Tipo inserto QTD Uni, forma EK	10-Uni		190
	9 - 50	2	2	✓	Inserito QTD Inox	02-Inox		191
	9 - 50	2	2	✓	Inserito QTD Iron	04-Iron		193
	9 - 50	2	2	✓	Inserito QTD Alu	03-Alu		194
	16 - 54,9	1	4	✓	Inserito a fissaggio meccanico WOGT	WOGT-X40		241

* n_{FF} = numero dei margini di guida

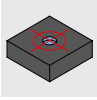

Foratura pilota

Design	Classe di prodotto	Idoneità del materiale						Caratteristica di foratura							Profondità di foratura					
		P	M	K	N	C	S	H	HFC	HSC	180°	Tolleranza	1xD	1,5xD	3xD	5xD	8xD	12xD		
	Expert LINE	■	■	■	■	■	■	■												
	Basic LINE	■	■	■	■	■	■	■												
	Basic LINE	■	■	■	■	■	■	■												

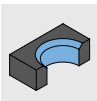

Foratura a gradino

Design	Classe di prodotto	Idoneità del materiale						Caratteristica di foratura							Profondità di foratura						
		P	M	K	N	C	S	H	HFC	HSC	180°	Tolleranza	1xD	1,5xD	3xD	5xD	8xD	12xD			
	Expert LINE	■	■	■	■	■	■	■	✓											IT9	
	Performance LINE	■	■	■	■	■	■	■													IT9



Foratura profonda

Design	Classe di prodotto	Idoneità del materiale						Caratteristica di foratura							Profondità di foratura							
		P	M	K	N	C	S	H	HFC	HSC	180°	Tolleranza	15xD	20xD	25xD	30xD	40xD					
	Performance LINE	■	■	■	■	■	■	■														
	Performance LINE	■	■	■	■	■	■	■				✓										IT9
	Performance LINE	■	■	■	■	■	■	■				✓										IT9



Foratura-alesatura

Design	Classe di prodotto	Idoneità del materiale						Caratteristica di foratura							Profondità di foratura							
		P	M	K	N	C	S	H	HFC	HSC	180°	Tolleranza	1xD	1,5xD	3xD	5xD	8xD	12xD				
	Expert LINE	■	■	■	■	■	■	■														IT7

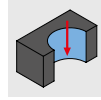
Fase 1:
ApplicazioneFase 2:
DesignFase 3:
Classe di prodottoFase 4:
Idoneità del materialeFase 5:
Caratteristiche del componenteFase 6:
Versione

Versione					Prodotto			
Ø [mm]	z	η _{FF} *			Nome del prodotto	Specifiche		Pagina
4 - 20	3	0			Tritan-Spot-Drill-Steel	SCD670		246
0,5 - 2,5	2	2			ECU-Centre-Drill	SCD450		248
8 - 20	2	0			CPD-Spot-Drill	CPD100		249

Versione					Prodotto			
Ø [mm]	z	η _{FF} *			Nome del prodotto	Specifiche		Pagina
3,98 - 17,50	3	3	✓		Tritan-Step-Drill-Steel	SCD561		258
2,5 - 14	2	2	✓		MEGA-Step-Drill-Steel-Plus	SCD590, 591		259

Versione					Prodotto			
Ø [mm]	z	η _{FF} *			Nome del prodotto	Specifiche		Pagina
1 - 3	2	2	✓		MEGA-Pilot-Drill	SCD581		268
1 - 16	2	4	✓		MEGA-Deep-Drill	SCD171		269
3 - 12	2	4	✓		MEGA-Deep-Drill-Alu	SCD181		278

Versione					Prodotto			
Ø [mm]	z	η _{FF} *			Nome del prodotto	Specifiche		Pagina
3,80 - 20,05	3		✓		Tritan-Drill-Reamer	SDR301		292

*η_{FF} = numero dei margini di guida

Codice di denominazione

Punta in metallo duro integrale

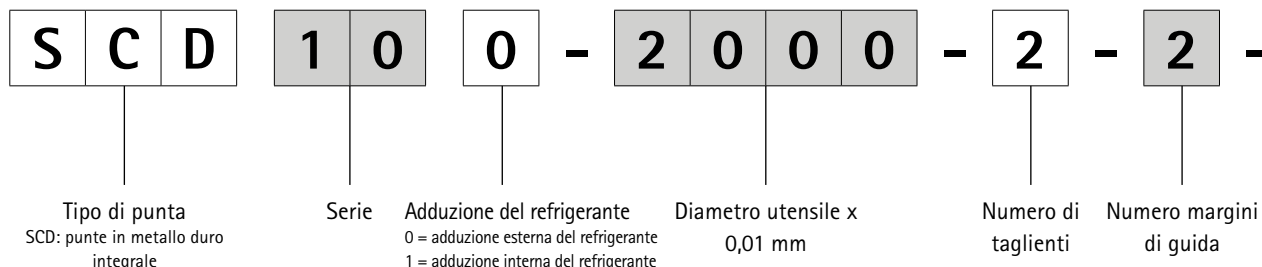

Foratore-alesatore

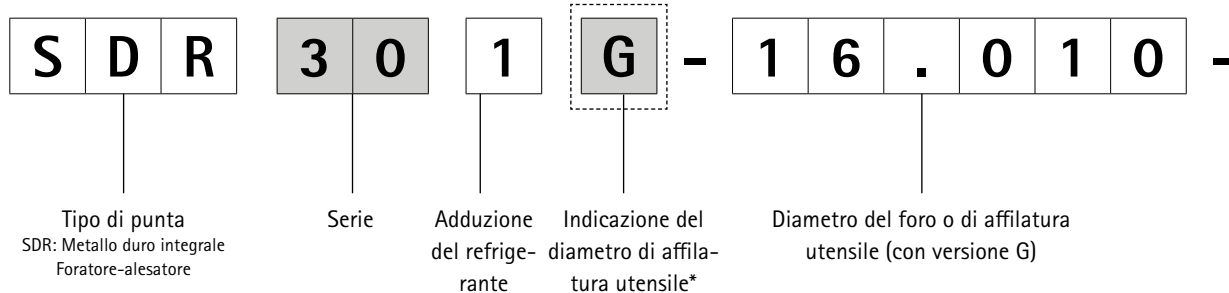

Sistema di cambio QTD e TTD

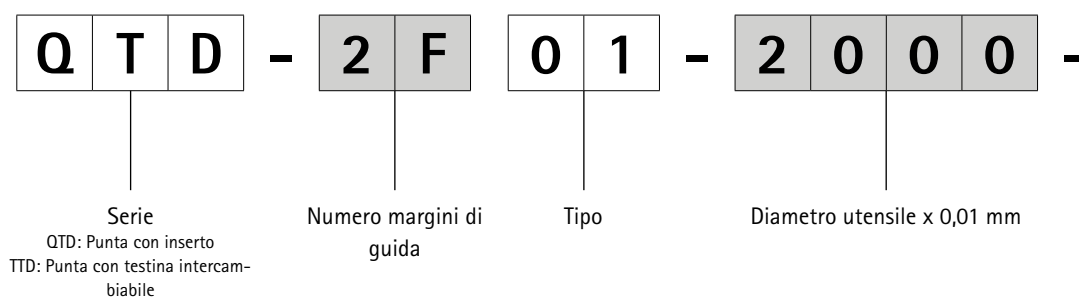

* Indicazione data solo per la versione G

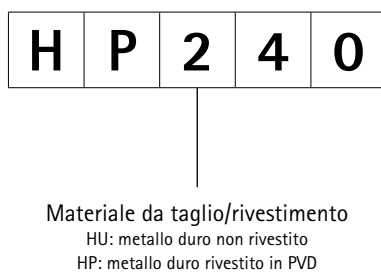
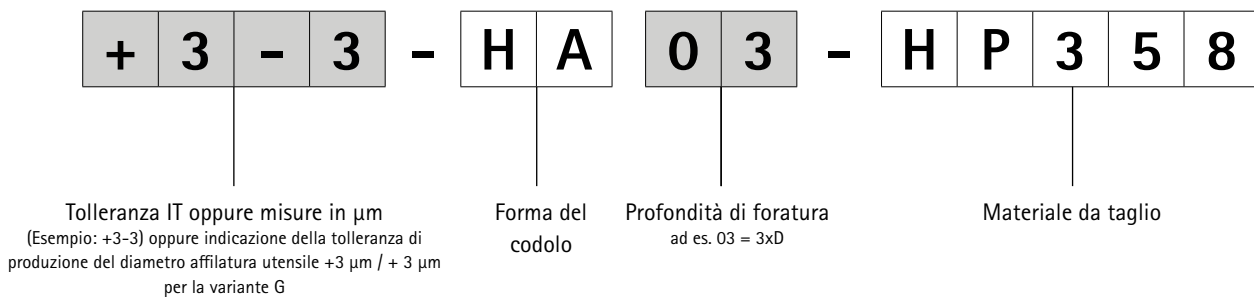
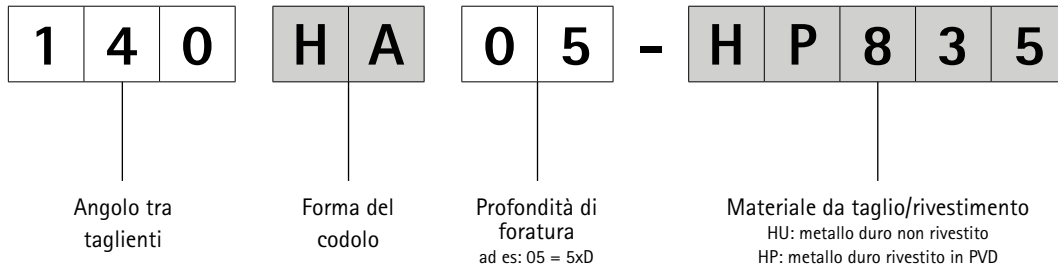

Codice di denominazione

Sistema di cambio TTD-Tritan

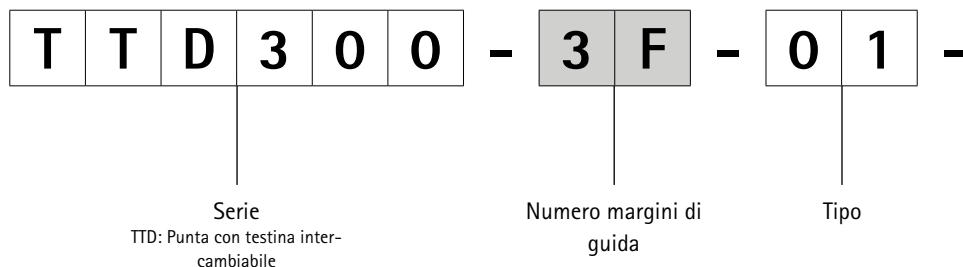

Assortimento supporti TTS per TTD-Tritan

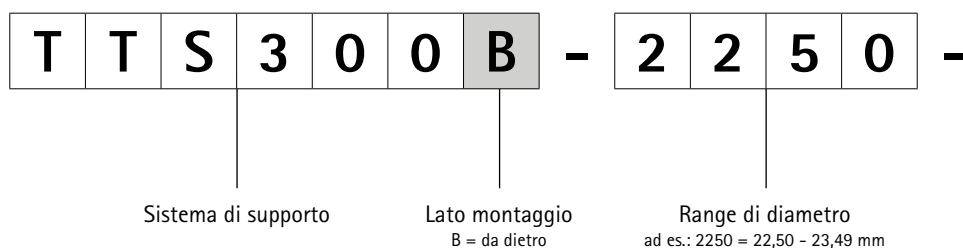

Assortimento supporti QTS per QTD

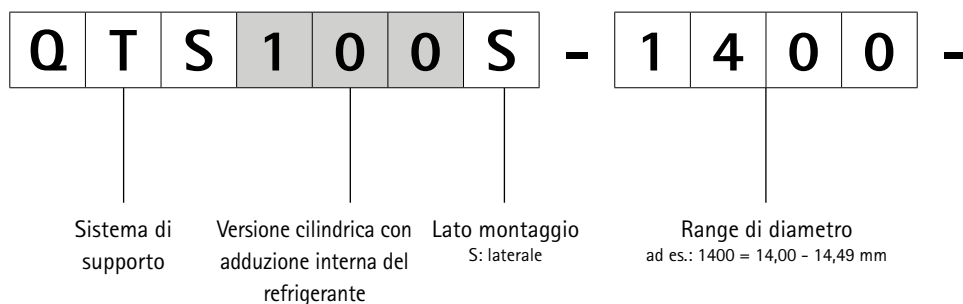

Assortimento supporti TTS per TTD

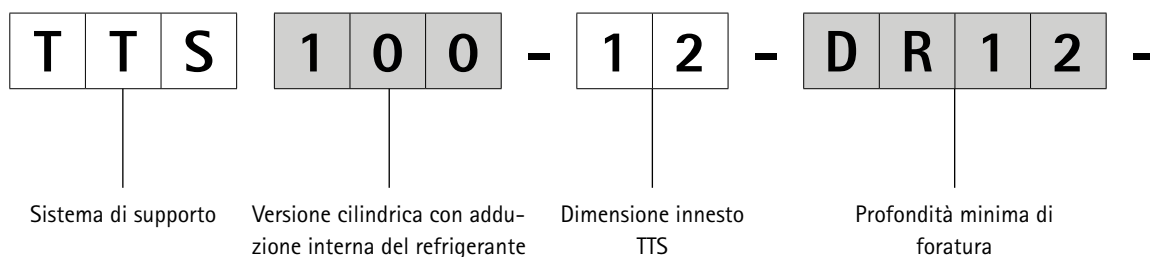

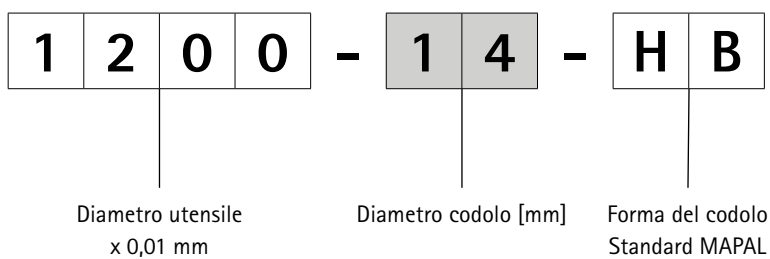
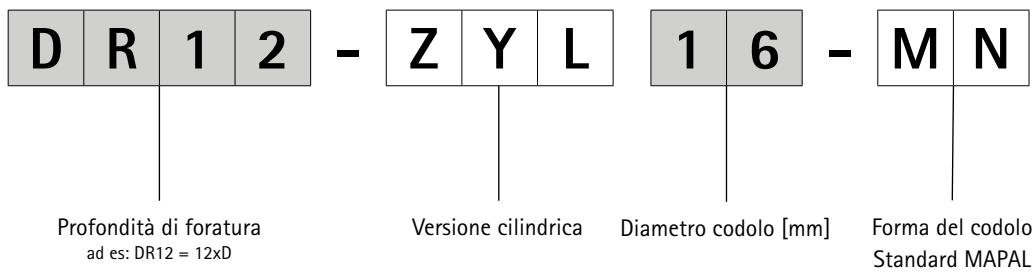
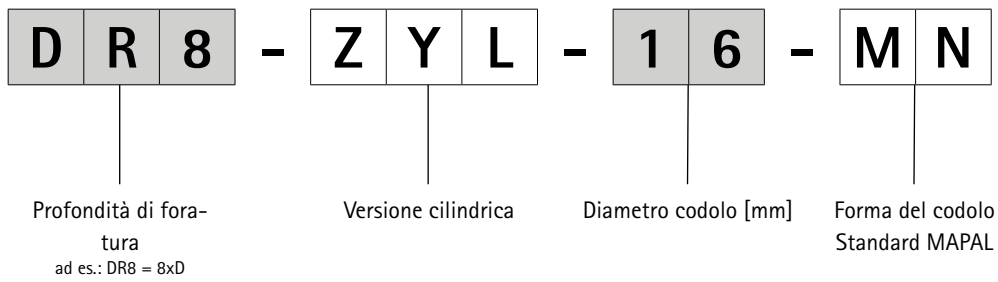
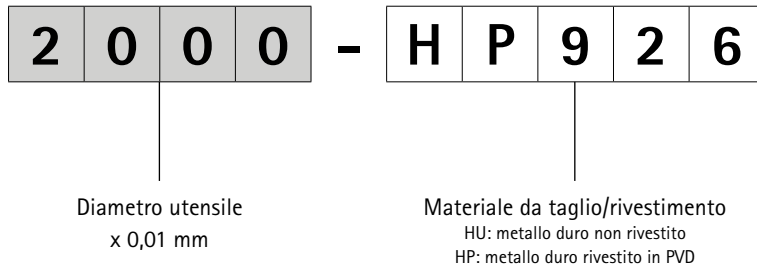



UTENSILI DI FORATURA IN METALLO DURO INTEGRALE

Impiego universale

Tritan-Drill-Uni-Plus	30
MEGA-Speed-Drill-Uni	36
ECU-Drill-Uni	42

Acciaio e acciaio temprato

MEGA-Drill-Steel-Plus	51
MEGA-Quadro-Drill-Plus	70
MICRO-Drill-Steel	79
MEGA-Drill-Hardened	82
Tritan-Drill-Steel	85
MEGA-Speed-Drill-Steel	95
MEGA-180°-Drill	105
ECU-Drill-Steel	111

Acciaio inossidabile e ghisa

MEGA-Drill-Inox	129
MEGA-Speed-Drill-Inox	142
MEGA-Speed-Drill-Iron	150

Alluminio e materiali compositi

MEGA-Drill-Alu	151
MEGA-Drill-Composite-MD	156
MEGA-Drill-Composite-UDX	158
MEGA-180°-Drill-Alu	160
ECU-G-Drill	164

Allegato tecnico

Parametri di lavorazione consigliati	166
--	-----



Tritan-Drill-Uni-Plus

Punta elicoidale in metallo duro integrale

SCD631 (5xD), adduzione interna del refrigerante, prodotto successivo a Tritan-Drill-Uni (SCD44)

Versione:

Diametro punta: 4,00 – 20,00 mm
 Tolleranza di foratura: IT 9 (raggiungibile)
 Materiale da taglio: HP358
 Numero di taglienti: 3
 Numero margini di guida: 3
 Angolo tra taglienti: 140°
 Angolo dell'elica: 30°

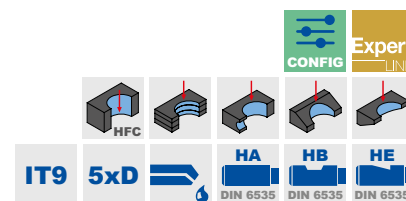
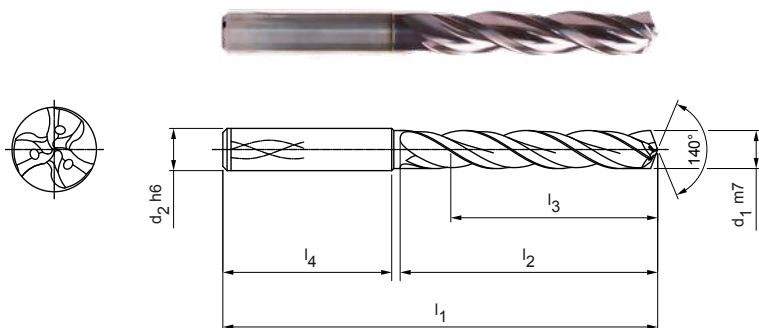

Serie selezionata per il magazzino con forma del codolo HA

Dimensioni						Forma del codolo HA	
d ₁ m7	d ₂ h6	l ₁	l ₂	l ₃	l ₄	Specifiche	Codice
4,00	6	74	36	29	36	SCD631-0400-3-3-140HA05-HP358	31037282
4,10	6	74	36	29	36	SCD631-0410-3-3-140HA05-HP358	31037283
4,20	6	74	36	29	36	SCD631-0420-3-3-140HA05-HP358	31037284
4,30	6	74	36	29	36	SCD631-0430-3-3-140HA05-HP358	31037285
4,50	6	74	36	29	36	SCD631-0450-3-3-140HA05-HP358	31037287
4,80	6	82	44	35	36	SCD631-0480-3-3-140HA05-HP358	31037290
5,00	6	82	44	35	36	SCD631-0500-3-3-140HA05-HP358	31037292
5,10	6	82	44	35	36	SCD631-0510-3-3-140HA05-HP358	31037293
5,20	6	82	44	35	36	SCD631-0520-3-3-140HA05-HP358	31037294
5,30	6	82	44	35	36	SCD631-0530-3-3-140HA05-HP358	31037295
5,50	6	82	44	35	36	SCD631-0550-3-3-140HA05-HP358	31037297
5,55	6	82	44	35	36	SCD631-0555-3-3-140HA05-HP358	31307521
5,60	6	82	44	35	36	SCD631-0560-3-3-140HA05-HP358	31037298
5,70	6	82	44	35	36	SCD631-0570-3-3-140HA05-HP358	31037299
5,80	6	82	44	35	36	SCD631-0580-3-3-140HA05-HP358	31037300
5,90	6	82	44	35	36	SCD631-0590-3-3-140HA05-HP358	31037301
6,00	6	82	44	35	36	SCD631-0600-3-3-140HA05-HP358	31037302
6,10	8	91	53	43	36	SCD631-0610-3-3-140HA05-HP358	31037303
6,20	8	91	53	43	36	SCD631-0620-3-3-140HA05-HP358	31037304
6,30	8	91	53	43	36	SCD631-0630-3-3-140HA05-HP358	31037305
6,40	8	91	53	43	36	SCD631-0640-3-3-140HA05-HP358	31037306
6,50	8	91	53	43	36	SCD631-0650-3-3-140HA05-HP358	31037307
6,70	8	91	53	43	36	SCD631-0670-3-3-140HA05-HP358	31037309
6,80	8	91	53	43	36	SCD631-0680-3-3-140HA05-HP358	31037310
6,90	8	91	53	43	36	SCD631-0690-3-3-140HA05-HP358	31037311
7,00	8	91	53	43	36	SCD631-0700-3-3-140HA05-HP358	31037312
7,40	8	91	53	43	36	SCD631-0740-3-3-140HA05-HP358	31037316
7,50	8	91	53	43	36	SCD631-0750-3-3-140HA05-HP358	31037317
7,70	8	91	53	43	36	SCD631-0770-3-3-140HA05-HP358	31037319
7,80	8	91	53	43	36	SCD631-0780-3-3-140HA05-HP358	31037320
7,90	8	91	53	43	36	SCD631-0790-3-3-140HA05-HP358	31037321
8,00	8	91	53	43	36	SCD631-0800-3-3-140HA05-HP358	31037322
8,10	10	103	61	49	40	SCD631-0810-3-3-140HA05-HP358	31037323
8,50	10	103	61	49	40	SCD631-0850-3-3-140HA05-HP358	31037327
8,60	10	103	61	49	40	SCD631-0860-3-3-140HA05-HP358	31037328

Tritan-Drill-Uni-Plus | Punta elicoidale in metallo duro integrale SCD631 (5xD), adduzione interna del refrigerante

Dimensioni						Forma del codolo HA	
d ₁ m7	d ₂ h6	l ₁	l ₂	l ₃	l ₄	Specifiche	Codice
8,80	10	103	61	49	40	SCD631-0880-3-3-140HA05-HP358	31037330
9,00	10	103	61	49	40	SCD631-0900-3-3-140HA05-HP358	31037332
9,30	10	103	61	49	40	SCD631-0930-3-3-140HA05-HP358	31037335
9,50	10	103	61	49	40	SCD631-0950-3-3-140HA05-HP358	31037337
9,80	10	103	61	49	40	SCD631-0980-3-3-140HA05-HP358	31037340
9,90	10	103	61	49	40	SCD631-0990-3-3-140HA05-HP358	31037341
10,00	10	103	61	49	40	SCD631-1000-3-3-140HA05-HP358	31037342
10,20	12	118	71	56	45	SCD631-1020-3-3-140HA05-HP358	31037344
10,50	12	118	71	56	45	SCD631-1050-3-3-140HA05-HP358	31037347
11,00	12	118	71	56	45	SCD631-1100-3-3-140HA05-HP358	31037352
11,20	12	118	71	56	45	SCD631-1120-3-3-140HA05-HP358	31037354
11,50	12	118	71	56	45	SCD631-1150-3-3-140HA05-HP358	31037357
11,70	12	118	71	56	45	SCD631-1170-3-3-140HA05-HP358	31037359
11,80	12	118	71	56	45	SCD631-1180-3-3-140HA05-HP358	31037360
12,00	12	118	71	56	45	SCD631-1200-3-3-140HA05-HP358	31037362
12,50	14	124	77	60	45	SCD631-1250-3-3-140HA05-HP358	31037364
13,00	14	124	77	60	45	SCD631-1300-3-3-140HA05-HP358	31037366
13,50	14	124	77	60	45	SCD631-1350-3-3-140HA05-HP358	31037368
13,80	14	124	77	60	45	SCD631-1380-3-3-140HA05-HP358	31037369
14,00	14	124	77	60	45	SCD631-1400-3-3-140HA05-HP358	31037370
14,50	16	133	83	63	48	SCD631-1450-3-3-140HA05-HP358	31037372
14,80	16	133	83	63	48	SCD631-1480-3-3-140HA05-HP358	31037373
15,00	16	133	83	63	48	SCD631-1500-3-3-140HA05-HP358	31037374
15,50	16	133	83	63	48	SCD631-1550-3-3-140HA05-HP358	31037376
16,00	16	133	83	63	48	SCD631-1600-3-3-140HA05-HP358	31037378
17,00	18	143	93	71	48	SCD631-1700-3-3-140HA05-HP358	31037382
17,50	18	143	93	71	48	SCD631-1750-3-3-140HA05-HP358	31037384
18,00	18	143	93	71	48	SCD631-1800-3-3-140HA05-HP358	31037386
18,50	20	153	101	77	50	SCD631-1850-3-3-140HA05-HP358	31037388
19,80	20	153	101	77	50	SCD631-1980-3-3-140HA05-HP358	31037393
20,00	20	153	101	77	50	SCD631-2000-3-3-140HA05-HP358	31037394

Caratteristiche configurabili

**Diametro:**

Diametro a libera scelta a passi da 0,01 mm

**Forma del codolo:**

Forma del codolo: HB | HE

**Specifiche:**

SCD631-[diametro]-3-3-140[forma del codolo]05-HP358

Dimensioni serie configurabile

d ₁ min.	d ₁ max.	d ₂ h6	l ₁	l ₂	l ₃	l ₄
4,00	4,70	6	74	36	29	36
4,71	6,00	6	82	44	35	36
6,01	8,00	8	91	53	43	36
8,01	10,00	10	103	61	49	40
10,01	12,00	12	118	71	56	45
12,01	14,00	14	124	77	60	45
14,01	16,00	16	133	83	63	48
16,01	18,00	18	143	93	71	48
18,01	20,00	20	153	101	77	50

Esempio:

SCD631-0431-3-3-140HE05-HP358

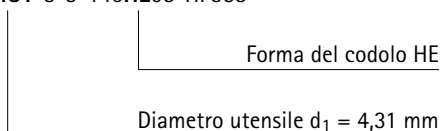

Misure in mm.

Per i parametri di lavorazione consigliati, vedere la fine del capitolo.

Versioni speciali e altri rivestimenti disponibili su richiesta.

Tritan-Drill-Uni-Plus

Punta elicoidale in metallo duro integrale

SCD631 (8xD), adduzione interna del refrigerante, prodotto successivo a Tritan-Drill-Uni (SCD44)

Versione:

Diametro punta: 4,00 – 20,00 mm
 Tolleranza di foratura: IT 9 (raggiungibile)
 Materiale da taglio: HP358
 Numero di taglienti: 3
 Numero margini di guida: 3
 Angolo tra taglienti: 135°
 Angolo dell'elica: 30°

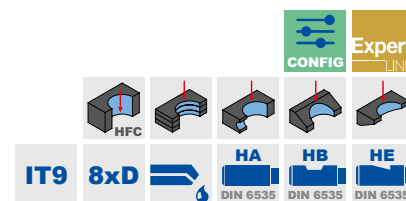
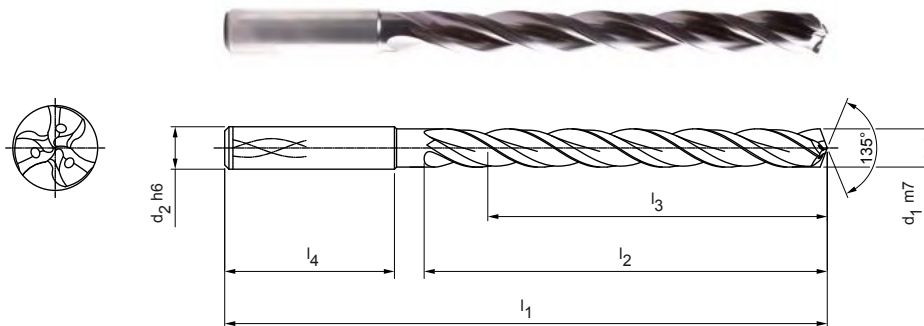

Serie selezionata per il magazzino con forma del codolo HA

Dimensioni						Forma del codolo HA	
d ₁ m7	d ₂ h6	l ₁	l ₂	l ₃	l ₄	Specifiche	Codice
4,00	6	81	43	36	36	SCD631-0400-3-3-135HA08-HP358	31037395
4,10	6	81	43	36	36	SCD631-0410-3-3-135HA08-HP358	31037396
4,30	6	81	43	36	36	SCD631-0430-3-3-135HA08-HP358	31037398
4,50	6	81	43	36	36	SCD631-0450-3-3-135HA08-HP358	31037400
4,60	6	81	43	36	36	SCD631-0460-3-3-135HA08-HP358	31037401
4,70	6	81	43	36	36	SCD631-0470-3-3-135HA08-HP358	31037402
4,90	6	95	57	48	36	SCD631-0490-3-3-135HA08-HP358	31037404
5,00	6	95	57	48	36	SCD631-0500-3-3-135HA08-HP358	31037405
5,03	6	95	57	48	36	SCD631-0503-3-3-135HA08-HP358	31266415
5,10	6	95	57	48	36	SCD631-0510-3-3-135HA08-HP358	31037406
5,20	6	95	57	48	36	SCD631-0520-3-3-135HA08-HP358	31037407
5,50	6	95	57	48	36	SCD631-0550-3-3-135HA08-HP358	31037410
5,60	6	95	57	48	36	SCD631-0560-3-3-135HA08-HP358	31037411
5,80	6	95	57	48	36	SCD631-0580-3-3-135HA08-HP358	31037413
6,00	6	95	57	48	36	SCD631-0600-3-3-135HA08-HP358	31037415
6,10	8	114	76	64	36	SCD631-0610-3-3-135HA08-HP358	31037416
6,50	8	114	76	64	36	SCD631-0650-3-3-135HA08-HP358	31037420
6,80	8	114	76	64	36	SCD631-0680-3-3-135HA08-HP358	31037423
6,90	8	114	76	64	36	SCD631-0690-3-3-135HA08-HP358	31037424
7,00	8	114	76	64	36	SCD631-0700-3-3-135HA08-HP358	31037425
7,10	8	114	76	64	36	SCD631-0710-3-3-135HA08-HP358	31037426
7,50	8	114	76	64	36	SCD631-0750-3-3-135HA08-HP358	31037430
7,80	8	114	76	64	36	SCD631-0780-3-3-135HA08-HP358	31037433
7,90	8	114	76	64	36	SCD631-0790-3-3-135HA08-HP358	31037434
8,00	8	114	76	64	36	SCD631-0800-3-3-135HA08-HP358	31037435
8,50	10	142	95	80	40	SCD631-0850-3-3-135HA08-HP358	31037440
8,80	10	142	95	80	40	SCD631-0880-3-3-135HA08-HP358	31037443
9,00	10	142	95	80	40	SCD631-0900-3-3-135HA08-HP358	31037445
9,10	10	142	95	80	40	SCD631-0910-3-3-135HA08-HP358	31037446
9,40	10	142	95	80	40	SCD631-0940-3-3-135HA08-HP358	31037449
9,50	10	142	95	80	40	SCD631-0950-3-3-135HA08-HP358	31037450
9,80	10	142	95	80	40	SCD631-0980-3-3-135HA08-HP358	31037453
10,00	10	142	95	80	40	SCD631-1000-3-3-135HA08-HP358	31037455
11,00	12	162	114	96	45	SCD631-1100-3-3-135HA08-HP358	31037465
11,80	12	162	114	96	45	SCD631-1180-3-3-135HA08-HP358	31037473

Tritan-Drill-Uni-Plus | Punta elicoidale in metallo duro integrale SCD631 (8xD), adduzione interna del refrigerante

Dimensioni						Forma del codolo HA	
d ₁ m7	d ₂ h6	l ₁	l ₂	l ₃	l ₄	Specifiche	Codice
12,00	12	162	114	96	45	SCD631-1200-3-3-135HA08-HP358	31037475
12,50	14	178	133	112	45	SCD631-1250-3-3-135HA08-HP358	31037477
13,00	14	178	133	112	45	SCD631-1300-3-3-135HA08-HP358	31037479
13,50	14	178	133	112	45	SCD631-1350-3-3-135HA08-HP358	31037481
14,00	14	178	133	112	45	SCD631-1400-3-3-135HA08-HP358	31037483
15,00	16	203	152	128	48	SCD631-1500-3-3-135HA08-HP358	31037487
16,00	16	203	152	128	48	SCD631-1600-3-3-135HA08-HP358	31037491
17,00	18	222	171	144	48	SCD631-1700-3-3-135HA08-HP358	31037495

Caratteristiche configurabili

**Diametro:**

Diametro a libera scelta a passi da 0,01 mm

**Forma del codolo:**

Forma del codolo: HB | HE

Specifiche:

SCD631-[diametro]-3-3-140[forma del codolo]08-HP358

Dimensioni serie configurabile

d ₁ min.	d ₁ max.	d ₂ h6	l ₁	l ₂	l ₃	l ₄
4,00	4,70	6	81	43	36	36
4,71	6,00	6	95	57	48	36
6,01	8,00	8	114	76	64	36
8,01	10,00	10	142	95	80	40
10,01	12,00	12	162	114	96	45
12,01	14,00	14	178	133	112	45
14,01	16,00	16	203	152	128	48
16,01	18,00	18	222	171	144	48
18,01	20,00	20	243	190	160	50

Esempio:

SCD631-0431-3-3-140HE08-HP358

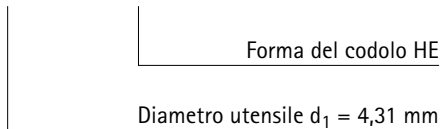

Misure in mm.

Per i parametri di lavorazione consigliati, vedere la fine del capitolo.

Versioni speciali e altri rivestimenti disponibili su richiesta.

Tritan-Drill-Uni-Plus

Punta elicoidale in metallo duro integrale

SCD631 (12xD), adduzione interna del refrigerante, prodotto successivo a Tritan-Drill-Uni (SCD44)

Versione:

Diametro punta: 4,00 – 20,00 mm
 Tolleranza di foratura: IT 9 (raggiungibile)
 Materiale da taglio: HP358
 Numero di taglianti: 3
 Numero margini di guida: 3
 Angolo tra taglianti: 135°
 Angolo dell'elica: 30°

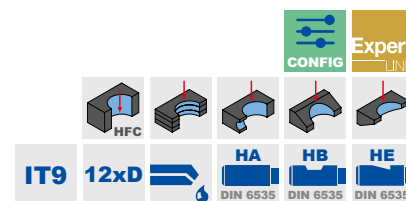
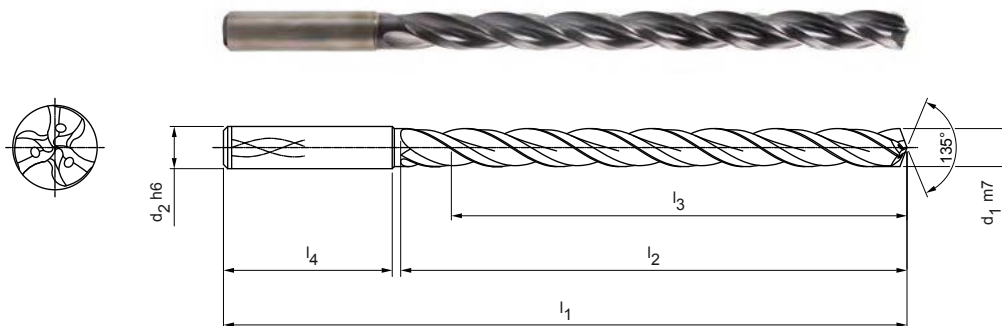

Serie selezionata per il magazzino con forma del codolo HA

Dimensioni						Forma del codolo HA	
d ₁ m7	d ₂ h6	l ₁	l ₂	l ₃	l ₄	Specifiche	Codice
4,00	6	102	64	58	36	SCD631-0400-3-3-135HA12-HP358	31035357
4,10	6	102	64	58	36	SCD631-0410-3-3-135HA12-HP358	31035358
4,20	6	102	64	58	36	SCD631-0420-3-3-135HA12-HP358	31035359
4,30	6	102	64	58	36	SCD631-0430-3-3-135HA12-HP358	31035360
4,50	6	102	64	58	36	SCD631-0450-3-3-135HA12-HP358	31035362
4,60	6	102	64	58	36	SCD631-0460-3-3-135HA12-HP358	31035363
4,70	6	102	64	58	36	SCD631-0470-3-3-135HA12-HP358	31035364
4,80	6	116	78	70	36	SCD631-0480-3-3-135HA12-HP358	31035365
5,00	6	116	78	70	36	SCD631-0500-3-3-135HA12-HP358	31035367
5,10	6	116	78	70	36	SCD631-0510-3-3-135HA12-HP358	31035368
5,20	6	116	78	70	36	SCD631-0520-3-3-135HA12-HP358	31035369
5,40	6	116	78	70	36	SCD631-0540-3-3-135HA12-HP358	31035371
5,50	6	116	78	70	36	SCD631-0550-3-3-135HA12-HP358	31035372
5,80	6	116	78	70	36	SCD631-0580-3-3-135HA12-HP358	31035375
6,00	6	116	78	70	36	SCD631-0600-3-3-135HA12-HP358	31035377
6,10	8	146	108	94	36	SCD631-0610-3-3-135HA12-HP358	31035378
6,20	8	146	108	94	36	SCD631-0620-3-3-135HA12-HP358	31035379
6,50	8	146	108	94	36	SCD631-0650-3-3-135HA12-HP358	31035382
6,60	8	146	108	94	36	SCD631-0660-3-3-135HA12-HP358	31035383
6,80	8	146	108	94	36	SCD631-0680-3-3-135HA12-HP358	31035385
7,00	8	146	108	94	36	SCD631-0700-3-3-135HA12-HP358	31035387
7,50	8	146	108	94	36	SCD631-0750-3-3-135HA12-HP358	31035392
7,80	8	146	108	94	36	SCD631-0780-3-3-135HA12-HP358	31035395
8,00	8	146	108	94	36	SCD631-0800-3-3-135HA12-HP358	31035397
8,50	10	162	120	110	40	SCD631-0850-3-3-135HA12-HP358	31035402
9,00	10	162	120	110	40	SCD631-0900-3-3-135HA12-HP358	31035407
9,50	10	162	120	110	40	SCD631-0950-3-3-135HA12-HP358	31035412
9,80	10	162	120	110	40	SCD631-0980-3-3-135HA12-HP358	31035415
9,90	10	162	120	110	40	SCD631-0990-3-3-135HA12-HP358	31035416
10,00	10	162	120	110	40	SCD631-1000-3-3-135HA12-HP358	31035417
10,20	12	204	156	142	45	SCD631-1020-3-3-135HA12-HP358	31035419
10,50	12	204	156	142	45	SCD631-1050-3-3-135HA12-HP358	31035422
11,00	12	204	156	142	45	SCD631-1100-3-3-135HA12-HP358	31035427
11,30	12	204	156	142	45	SCD631-1130-3-3-135HA12-HP358	31035430
11,80	12	204	156	142	45	SCD631-1180-3-3-135HA12-HP358	31035435

Tritan-Drill-Uni-Plus | Punta elicoidale in metallo duro integrale SCD631 (12xD), adduzione interna del refrigerante

Dimensioni						Forma del codolo HA	
d ₁ m7	d ₂ h6	l ₁	l ₂	l ₃	l ₄	Specifiche	Codice
12,00	12	204	156	142	45	SCD631-1200-3-3-135HA12-HP358	31035437
12,50	14	230	182	166	45	SCD631-1250-3-3-135HA12-HP358	31035439
13,00	14	230	182	166	45	SCD631-1300-3-3-135HA12-HP358	31035441
13,50	14	230	182	166	45	SCD631-1350-3-3-135HA12-HP358	31035443
13,80	14	230	182	166	45	SCD631-1380-3-3-135HA12-HP358	31035444
14,00	14	230	182	166	45	SCD631-1400-3-3-135HA12-HP358	31035445
15,00	16	260	208	192	48	SCD631-1500-3-3-135HA12-HP358	31035449
15,80	16	260	208	192	48	SCD631-1580-3-3-135HA12-HP358	31035452
16,00	16	260	208	192	48	SCD631-1600-3-3-135HA12-HP358	31035453

Caratteristiche configurabili

**Diametro:**

Diametro a libera scelta a passi da 0,01 mm

**Forma del codolo:**

Forma del codolo: HB | HE

Specifiche:

SCD631-[diametro]-3-3-140[forma del codolo]12-HP358

Dimensioni serie configurabile

d ₁ min.	d ₁ max.	d ₂ h6	l ₁	l ₂	l ₃	l ₄
4,00	4,70	6	102	64	58	36
4,71	6,00	6	116	78	70	36
6,01	8,00	8	146	108	94	36
8,01	10,00	10	162	120	110	40
10,01	12,00	12	204	156	142	45
12,01	14,00	14	230	182	166	45
14,01	16,00	16	260	208	192	48
16,01	18,00	18	285	234	216	48
18,01	20,00	20	310	258	240	50

Esempio:

SCD631-0431-3-3-140HE12-HP358

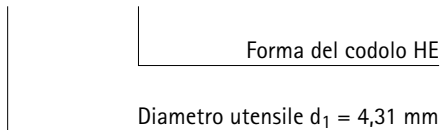

Misure in mm.

Per i parametri di lavorazione consigliati, vedere la fine del capitolo.

Versioni speciali e altri rivestimenti disponibili su richiesta.

MEGA-Speed-Drill-Uni

Punta elicoidale in metallo duro integrale
SCD221 (3xD), adduzione interna del refrigerante

Versione:

Diametro punta: 3,00 – 20,00 mm
Tolleranza di foratura: \geq IT 9
Materiale da taglio: HP374
Numero di taglienti: 2
Numero margini di guida: 3
Angolo tra taglienti: 135°
Angolo dell'elica: 30°

Applicazione

Per lavorazioni ad alta velocità.

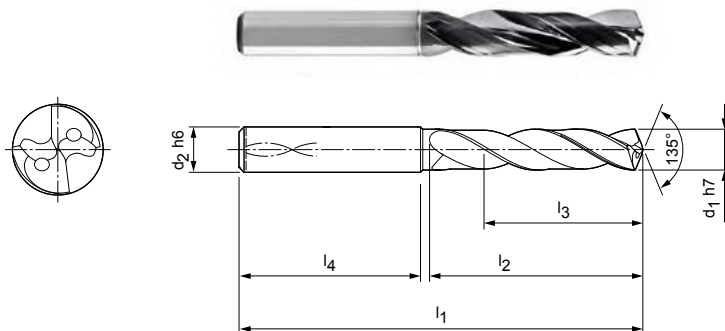

Serie selezionata per il magazzino con forma del codolo HA

Dimensioni						Forma del codolo HA	
d_1 h7	d_2 h6	l_1	l_2	l_3	l_4	Specifiche	Codice
3,00	6	62	20	14	36	SCD221-0300-2-3-135HA03-HP374	30404127
3,10	6	62	20	14	36	SCD221-0310-2-3-135HA03-HP374	30404128
3,20	6	62	20	14	36	SCD221-0320-2-3-135HA03-HP374	30404129
3,30	6	62	20	14	36	SCD221-0330-2-3-135HA03-HP374	30404130
3,40	6	62	20	14	36	SCD221-0340-2-3-135HA03-HP374	30404131
3,50	6	62	20	14	36	SCD221-0350-2-3-135HA03-HP374	30404132
3,70	6	62	20	14	36	SCD221-0370-2-3-135HA03-HP374	30404134
4,00	6	66	24	17	36	SCD221-0400-2-3-135HA03-HP374	30404137
4,20	6	66	24	17	36	SCD221-0420-2-3-135HA03-HP374	30404139
4,30	6	66	24	17	36	SCD221-0430-2-3-135HA03-HP374	30404140
4,50	6	66	24	17	36	SCD221-0450-2-3-135HA03-HP374	30404142
5,00	6	66	28	20	36	SCD221-0500-2-3-135HA03-HP374	30404148
5,10	6	66	28	20	36	SCD221-0510-2-3-135HA03-HP374	30404149
5,20	6	66	28	20	36	SCD221-0520-2-3-135HA03-HP374	30404150
5,50	6	66	28	20	36	SCD221-0550-2-3-135HA03-HP374	30404153
5,55	6	66	28	20	36	SCD221-0555-2-3-135HA03-HP374	30404154
5,60	6	66	28	20	36	SCD221-0560-2-3-135HA03-HP374	30404155
5,80	6	66	28	20	36	SCD221-0580-2-3-135HA03-HP374	30404157
6,00	6	66	28	20	36	SCD221-0600-2-3-135HA03-HP374	30404159
6,30	8	79	34	24	36	SCD221-0630-2-3-135HA03-HP374	30404162
6,50	8	79	34	24	36	SCD221-0650-2-3-135HA03-HP374	30404164
6,80	8	79	34	24	36	SCD221-0680-2-3-135HA03-HP374	30404167
6,90	8	79	34	24	36	SCD221-0690-2-3-135HA03-HP374	30404168
7,00	8	79	34	24	36	SCD221-0700-2-3-135HA03-HP374	30404169
7,40	8	79	41	29	36	SCD221-0740-2-3-135HA03-HP374	30404173
7,50	8	79	41	29	36	SCD221-0750-2-3-135HA03-HP374	30404175
7,80	8	79	41	29	36	SCD221-0780-2-3-135HA03-HP374	30404178
8,00	8	79	41	29	36	SCD221-0800-2-3-135HA03-HP374	30404180
8,50	10	89	47	35	40	SCD221-0850-2-3-135HA03-HP374	30404185
8,60	10	89	47	35	40	SCD221-0860-2-3-135HA03-HP374	30404186
8,80	10	89	47	35	40	SCD221-0880-2-3-135HA03-HP374	30404188
9,00	10	89	47	35	40	SCD221-0900-2-3-135HA03-HP374	30404190
9,50	10	89	47	35	40	SCD221-0950-2-3-135HA03-HP374	30404195
9,80	10	89	47	35	40	SCD221-0980-2-3-135HA03-HP374	30404198
9,90	10	89	47	35	40	SCD221-0990-2-3-135HA03-HP374	30404199

MEGA-Speed-Drill-Uni | Punta elicoidale in metallo duro integrale SCD221 (3xD), adduzione interna del refrigerante

Dimensioni						Forma del codolo HA	
d ₁ h7	d ₂ h6	l ₁	l ₂	l ₃	l ₄	Specifiche	Codice
10,00	10	89	47	35	40	SCD221-1000-2-3-135HA03-HP374	30404200
10,20	12	102	55	40	45	SCD221-1020-2-3-135HA03-HP374	30404202
10,30	12	102	55	40	45	SCD221-1030-2-3-135HA03-HP374	30404203
10,50	12	102	55	40	45	SCD221-1050-2-3-135HA03-HP374	30404205
10,60	12	102	55	40	45	SCD221-1060-2-3-135HA03-HP374	30404206
11,00	12	102	55	40	45	SCD221-1100-2-3-135HA03-HP374	30404210
11,50	12	102	55	40	45	SCD221-1150-2-3-135HA03-HP374	30404215
11,60	12	102	55	40	45	SCD221-1160-2-3-135HA03-HP374	30404216
11,80	12	102	55	40	45	SCD221-1180-2-3-135HA03-HP374	30404219
12,00	12	102	55	40	45	SCD221-1200-2-3-135HA03-HP374	30404221
12,50	14	107	60	43	45	SCD221-1250-2-3-135HA03-HP374	30404222
13,00	14	107	60	43	45	SCD221-1300-2-3-135HA03-HP374	30404224
13,50	14	107	60	43	45	SCD221-1350-2-3-135HA03-HP374	30404225
14,00	14	107	60	43	45	SCD221-1400-2-3-135HA03-HP374	30404227
14,50	16	115	65	45	48	SCD221-1450-2-3-135HA03-HP374	30404228
15,00	16	115	65	45	48	SCD221-1500-2-3-135HA03-HP374	30404230
16,00	16	115	65	45	48	SCD221-1600-2-3-135HA03-HP374	30404233
17,00	18	123	73	51	48	SCD221-1700-2-3-135HA03-HP374	30404236
17,50	18	123	73	51	48	SCD221-1750-2-3-135HA03-HP374	30404237
17,80	18	123	73	51	48	SCD221-1780-2-3-135HA03-HP374	30404238
18,00	18	123	73	51	48	SCD221-1800-2-3-135HA03-HP374	30404239
18,50	20	131	79	55	50	SCD221-1850-2-3-135HA03-HP374	30404240
19,50	20	131	79	55	50	SCD221-1950-2-3-135HA03-HP374	30404243
20,00	20	131	79	55	50	SCD221-2000-2-3-135HA03-HP374	30404245

Caratteristiche configurabili

**Diametro:**

Diametro a libera scelta a passi da 0,01 mm

**Forma del codolo:**

Forma del codolo: HB | HE

Specifiche:

SCD221-[diametro]-3-3-140[forma del codolo]03-HP358

Dimensioni serie configurabile

d ₁ min.	d ₁ max.	d ₂ h6	l ₁	l ₂	l ₃	l ₄
3,00	3,70	6	62	20	14	36
3,71	4,70	6	66	24	17	36
4,71	6,00	6	66	28	20	36
6,01	8,00	8	79	34	24	36
8,01	10,00	10	89	47	35	40
10,01	12,00	12	102	55	40	45
12,01	14,00	14	107	60	43	45
14,01	16,00	16	115	65	45	48
16,01	18,00	18	123	73	51	48
18,01	20,00	20	131	79	55	50

Esempio:

SCD221-0431-3-3-140HE03-HP358

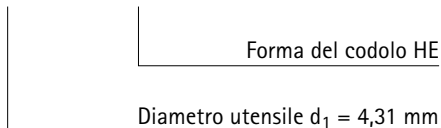

Misure in mm.

Per i parametri di lavorazione consigliati, vedere la fine del capitolo.

Versioni speciali e altri rivestimenti disponibili su richiesta.

MEGA-Speed-Drill-Uni

Punta elicoidale in metallo duro integrale
SCD221 (5xD), adduzione interna del refrigerante

Versione:
 Diametro punta: 3,00 – 20,00 mm
 Tolleranza di foratura: \geq IT 9
 Materiale da taglio: HP374
 Numero di taglienti: 2
 Numero margini di guida: 3
 Angolo tra taglienti: 135°
 Angolo dell'elica: 30°

Applicazione
 Per lavorazioni ad alta velocità.

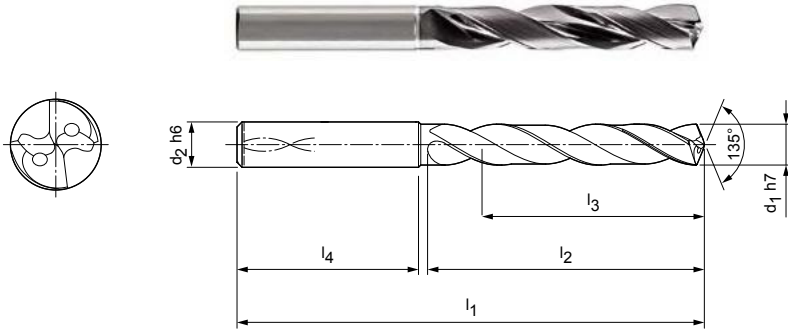

Serie selezionata per il magazzino con forma del codolo HA

Dimensioni						Forma del codolo HA	
d ₁ h7	d ₂ h6	l ₁	l ₂	l ₃	l ₄	Specifiche	Codice
3,00	6	66	28	23	36	SCD221-0300-2-3-135HA05-HP374	30392925
3,10	6	66	28	23	36	SCD221-0310-2-3-135HA05-HP374	30392926
3,20	6	66	28	23	36	SCD221-0320-2-3-135HA05-HP374	30392927
3,30	6	66	28	23	36	SCD221-0330-2-3-135HA05-HP374	30392928
3,40	6	66	28	23	36	SCD221-0340-2-3-135HA05-HP374	30392929
3,50	6	66	28	23	36	SCD221-0350-2-3-135HA05-HP374	30392930
3,70	6	66	28	23	36	SCD221-0370-2-3-135HA05-HP374	30392932
4,00	6	74	36	29	36	SCD221-0400-2-3-135HA05-HP374	30392935
4,20	6	74	36	29	36	SCD221-0420-2-3-135HA05-HP374	30392937
4,30	6	74	36	29	36	SCD221-0430-2-3-135HA05-HP374	30392938
4,50	6	74	36	29	36	SCD221-0450-2-3-135HA05-HP374	30392940
5,00	6	82	44	35	36	SCD221-0500-2-3-135HA05-HP374	30392946
5,10	6	82	44	35	36	SCD221-0510-2-3-135HA05-HP374	30392947
5,20	6	82	44	35	36	SCD221-0520-2-3-135HA05-HP374	30392948
5,50	6	82	44	35	36	SCD221-0550-2-3-135HA05-HP374	30392951
5,60	6	82	44	35	36	SCD221-0560-2-3-135HA05-HP374	30392953
5,80	6	82	44	35	36	SCD221-0580-2-3-135HA05-HP374	30392955
6,00	6	82	44	35	36	SCD221-0600-2-3-135HA05-HP374	30392957
6,50	8	91	53	43	36	SCD221-0650-2-3-135HA05-HP374	30392962
6,60	8	91	53	43	36	SCD221-0660-2-3-135HA05-HP374	30392963
6,80	8	91	53	43	36	SCD221-0680-2-3-135HA05-HP374	30392965
6,90	8	91	53	43	36	SCD221-0690-2-3-135HA05-HP374	30392966
7,00	8	91	53	43	36	SCD221-0700-2-3-135HA05-HP374	30392967
7,40	8	91	53	43	36	SCD221-0740-2-3-135HA05-HP374	30392971
7,50	8	91	53	43	36	SCD221-0750-2-3-135HA05-HP374	30392972
7,80	8	91	53	43	36	SCD221-0780-2-3-135HA05-HP374	30392975
8,00	8	91	53	43	36	SCD221-0800-2-3-135HA05-HP374	30392977
8,50	10	103	61	49	40	SCD221-0850-2-3-135HA05-HP374	30392982
8,60	10	103	61	49	40	SCD221-0860-2-3-135HA05-HP374	30392983
8,80	10	103	61	49	40	SCD221-0880-2-3-135HA05-HP374	30392985
9,00	10	103	61	49	40	SCD221-0900-2-3-135HA05-HP374	30392987
9,50	10	103	61	49	40	SCD221-0950-2-3-135HA05-HP374	30392992
9,70	10	103	61	49	40	SCD221-0970-2-3-135HA05-HP374	30392994
9,80	10	103	61	49	40	SCD221-0980-2-3-135HA05-HP374	30392995
10,00	10	103	61	49	40	SCD221-1000-2-3-135HA05-HP374	30392997

MEGA-Speed-Drill-Uni | Punta elicoidale in metallo duro integrale SCD221 (5xD), adduzione interna del refrigerante

Dimensioni						Forma del codolo HA	
d ₁ h7	d ₂ h6	l ₁	l ₂	l ₃	l ₄	Specifiche	Codice
10,20	12	118	71	56	45	SCD221-1020-2-3-135HA05-HP374	30392999
10,30	12	118	71	56	45	SCD221-1030-2-3-135HA05-HP374	30393000
10,50	12	118	71	56	45	SCD221-1050-2-3-135HA05-HP374	30393002
11,00	12	118	71	56	45	SCD221-1100-2-3-135HA05-HP374	30393007
11,50	12	118	71	56	45	SCD221-1150-2-3-135HA05-HP374	30393012
11,80	12	118	71	56	45	SCD221-1180-2-3-135HA05-HP374	30393015
12,00	12	118	71	56	45	SCD221-1200-2-3-135HA05-HP374	30393017
12,50	14	124	77	60	45	SCD221-1250-2-3-135HA05-HP374	30393018
13,00	14	124	77	60	45	SCD221-1300-2-3-135HA05-HP374	30393020
13,50	14	124	77	60	45	SCD221-1350-2-3-135HA05-HP374	30393021
13,80	14	124	77	60	45	SCD221-1380-2-3-135HA05-HP374	30393022
14,00	14	124	77	60	45	SCD221-1400-2-3-135HA05-HP374	30393023
14,50	16	133	83	63	48	SCD221-1450-2-3-135HA05-HP374	30393024
15,00	16	133	83	63	48	SCD221-1500-2-3-135HA05-HP374	30393026
15,50	16	133	83	63	48	SCD221-1550-2-3-135HA05-HP374	30393027
15,80	16	133	83	63	48	SCD221-1580-2-3-135HA05-HP374	30393028
16,00	16	133	83	63	48	SCD221-1600-2-3-135HA05-HP374	30393029
16,80	18	143	93	71	48	SCD221-1680-2-3-135HA05-HP374	30393031
17,00	18	143	93	71	48	SCD221-1700-2-3-135HA05-HP374	30393032
17,50	18	143	93	71	48	SCD221-1750-2-3-135HA05-HP374	30393033
17,80	18	143	93	71	48	SCD221-1780-2-3-135HA05-HP374	30393034
18,00	18	143	93	71	48	SCD221-1800-2-3-135HA05-HP374	30393035
18,50	20	153	101	77	50	SCD221-1850-2-3-135HA05-HP374	30393036
18,80	20	153	101	77	50	SCD221-1880-2-3-135HA05-HP374	30393037
19,00	20	153	101	77	50	SCD221-1900-2-3-135HA05-HP374	30393038
20,00	20	153	101	77	50	SCD221-2000-2-3-135HA05-HP374	30393041

Caratteristiche configurabili

**Diametro:**

Diametro a libera scelta a passi da 0,01 mm

**Forma del codolo:**

Forma del codolo: HB | HE

Specifiche:

SCD221-[diametro]-3-3-140[forma del codolo]05-HP358

Dimensioni serie configurabile

d ₁ min.	d ₁ max.	d ₂ h6	l ₁	l ₂	l ₃	l ₄
3,00	3,70	6	66	28	23	36
3,71	4,70	6	74		29	36
4,71	6,00	6	82	44	35	36
6,01	8,00	8	91	53	43	36
8,01	10,00	10	103	61	49	40
10,01	12,00	12	118	71	56	45
12,01	14,00	14	124	77	60	45
14,01	16,00	16	133	83	63	48
16,01	18,00	18	143	93	71	48
18,01	20,00	20	153	101	77	50

Esempio:

SCD221-0431-3-3-140HE05-HP374

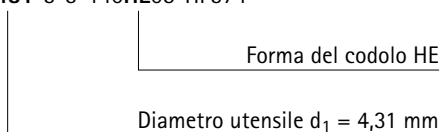

Misure in mm.

Per i parametri di lavorazione consigliati, vedere la fine del capitolo.

Versioni speciali e altri rivestimenti disponibili su richiesta.

MEGA-Speed-Drill-Uni

Punta elicoidale in metallo duro integrale
SCD221 (8xD), adduzione interna del refrigerante

Versione:

Diametro punta: 3,00 – 20,00 mm
Tolleranza di foratura: \geq IT 9
Materiale da taglio: HP374
Numero di taglienti: 2
Numero margini di guida: 3
Angolo tra taglienti: 135°
Angolo dell'elica: 30°

Applicazione

Per lavorazioni ad alta velocità.

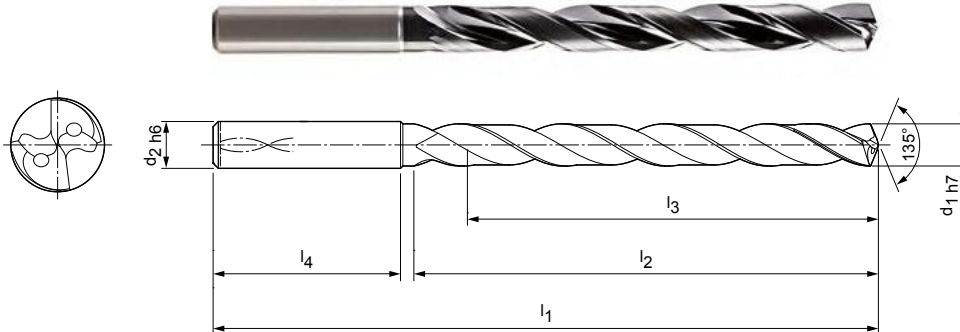

Serie selezionata per il magazzino con forma del codolo HA

Dimensioni						Forma del codolo HA	
d ₁ h7	d ₂ h6	l ₁	l ₂	l ₃	l ₄	Specifiche	Codice
3,00	6	72	34	29	36	SCD221-0300-2-3-135HA08-HP374	30404000
3,20	6	72	34	29	36	SCD221-0320-2-3-135HA08-HP374	30404002
3,30	6	72	34	29	36	SCD221-0330-2-3-135HA08-HP374	30404003
3,40	6	72	34	29	36	SCD221-0340-2-3-135HA08-HP374	30404004
3,50	6	72	34	29	36	SCD221-0350-2-3-135HA08-HP374	30404005
3,70	6	72	34	29	36	SCD221-0370-2-3-135HA08-HP374	30404007
4,00	6	81	43	36	36	SCD221-0400-2-3-135HA08-HP374	30404010
4,10	6	81	43	36	36	SCD221-0410-2-3-135HA08-HP374	30404011
4,20	6	81	43	36	36	SCD221-0420-2-3-135HA08-HP374	30404012
4,30	6	81	43	36	36	SCD221-0430-2-3-135HA08-HP374	30404013
4,50	6	81	43	36	36	SCD221-0450-2-3-135HA08-HP374	30404015
4,80	6	95	57	48	36	SCD221-0480-2-3-135HA08-HP374	30404019
5,00	6	95	57	48	36	SCD221-0500-2-3-135HA08-HP374	30404021
5,10	6	95	57	48	36	SCD221-0510-2-3-135HA08-HP374	30404022
5,20	6	95	57	48	36	SCD221-0520-2-3-135HA08-HP374	30404023
5,40	6	95	57	48	36	SCD221-0540-2-3-135HA08-HP374	30404025
5,50	6	95	57	48	36	SCD221-0550-2-3-135HA08-HP374	30404026
5,80	6	95	57	48	36	SCD221-0580-2-3-135HA08-HP374	30404030
6,00	6	95	57	48	36	SCD221-0600-2-3-135HA08-HP374	30404032
6,10	8	114	76	64	36	SCD221-0610-2-3-135HA08-HP374	30404033
6,40	8	114	76	64	36	SCD221-0640-2-3-135HA08-HP374	30404036
6,50	8	114	76	64	36	SCD221-0650-2-3-135HA08-HP374	30404037
6,80	8	114	76	64	36	SCD221-0680-2-3-135HA08-HP374	30404040
7,00	8	114	76	64	36	SCD221-0700-2-3-135HA08-HP374	30404043
7,50	8	114	76	64	36	SCD221-0750-2-3-135HA08-HP374	30404048
7,80	8	114	76	64	36	SCD221-0780-2-3-135HA08-HP374	30404051
8,00	8	114	76	64	36	SCD221-0800-2-3-135HA08-HP374	30404053
8,50	10	142	95	80	40	SCD221-0850-2-3-135HA08-HP374	30404058
9,00	10	142	95	80	40	SCD221-0900-2-3-135HA08-HP374	30404063
9,30	10	142	95	80	40	SCD221-0930-2-3-135HA08-HP374	30404066
9,50	10	142	95	80	40	SCD221-0950-2-3-135HA08-HP374	30404068
9,60	10	142	95	80	40	SCD221-0960-2-3-135HA08-HP374	30404069
9,80	10	142	95	80	40	SCD221-0980-2-3-135HA08-HP374	30404071
10,00	10	142	95	80	40	SCD221-1000-2-3-135HA08-HP374	30404073
10,20	12	162	114	96	45	SCD221-1020-2-3-135HA08-HP374	30404075

MEGA-Speed-Drill-Uni | Punta elicoidale in metallo duro integrale SCD221 (8xD), adduzione interna del refrigerante

Dimensioni						Forma del codolo HA	
d ₁ h7	d ₂ h6	l ₁	l ₂	l ₃	l ₄	Specifiche	Codice
10,50	12	162	114	96	45	SCD221-1050-2-3-135HA08-HP374	30404078
11,00	12	162	114	96	45	SCD221-1100-2-3-135HA08-HP374	30404083
11,40	12	162	114	96	45	SCD221-1140-2-3-135HA08-HP374	30404088
11,80	12	162	114	96	45	SCD221-1180-2-3-135HA08-HP374	30404092
12,00	12	162	114	96	45	SCD221-1200-2-3-135HA08-HP374	30404094
12,50	14	178	133	112	45	SCD221-1250-2-3-135HA08-HP374	30404095
13,00	14	178	133	112	45	SCD221-1300-2-3-135HA08-HP374	30404097
13,50	14	178	133	112	45	SCD221-1350-2-3-135HA08-HP374	30404098
14,00	14	178	133	112	45	SCD221-1400-2-3-135HA08-HP374	30404100
15,00	16	203	152	128	48	SCD221-1500-2-3-135HA08-HP374	30404103
16,00	16	203	152	128	48	SCD221-1600-2-3-135HA08-HP374	30404106
17,50	18	222	171	144	48	SCD221-1750-2-3-135HA08-HP374	30404110

Caratteristiche configurabili

**Diametro:**

Diametro a libera scelta a passi da 0,01 mm

**Forma del codolo:**

Forma del codolo: HB | HE

Specifiche:

SCD221-[diametro]-3-3-140[forma del codolo]08-HP374

Dimensioni serie configurabile

d ₁ min.	d ₁ max.	d ₂ h6	l ₁	l ₂	l ₃	l ₄
3,00	3,70	6	72	34	29	36
3,71	4,70	6	81	43	36	36
4,80	6,00	6	95	57	48	36
6,01	8,00	8	114	76	64	36
8,01	10,00	10	142	95	80	40
10,01	12,00	12	162	114	96	45
12,01	14,00	14	178	133	112	45
14,01	16,00	16	203	152	128	48
16,01	18,00	18	222	171	144	48
18,01	20,00	20	243	190	160	50

Esempio:

SCD221-0431-3-3-140HE08-HP374

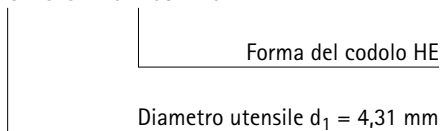

Misure in mm.

Per i parametri di lavorazione consigliati, vedere la fine del capitolo.

Versioni speciali e altri rivestimenti disponibili su richiesta.

ECU-Drill-Uni

Punta elicoidale in metallo duro integrale
SCD351 (4xD), adduzione interna del refrigerante

Versione:

Diametro punta: 3,00 - 20,00 mm
Tolleranza di foratura: \geq IT 9
Materiale da taglio: HP765
Numero di taglienti: 2
Angolo tra taglienti: 140°
Angolo dell'elica: 30°

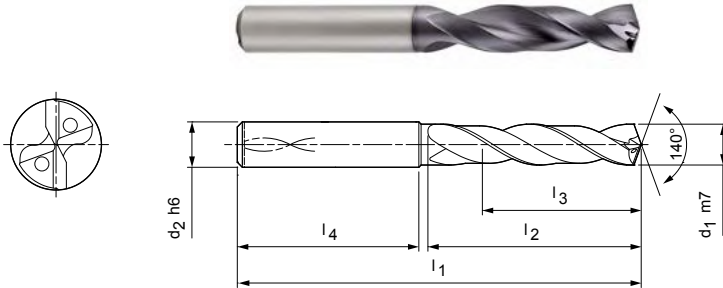

Serie selezionata per il magazzino con forma del codolo HA

Dimensioni						Forma del codolo HA	
d ₁ m7	d ₂ h6	l ₁	l ₂	l ₃	l ₄	Specifiche	Codice
3,00	6	62	22	16	36	SCD351-0300-2-2-140HA04-HP765	30421828
3,10	6	62	22	16	36	SCD351-0310-2-2-140HA04-HP765	30421829
3,20	6	62	22	16	36	SCD351-0320-2-2-140HA04-HP765	30421830
3,30	6	62	22	16	36	SCD351-0330-2-2-140HA04-HP765	30421831
3,40	6	62	22	16	36	SCD351-0340-2-2-140HA04-HP765	30421832
3,50	6	62	22	16	36	SCD351-0350-2-2-140HA04-HP765	30421833
3,60	6	62	22	16	36	SCD351-0360-2-2-140HA04-HP765	30421834
3,70*	6	62	22	16	36	SCD351-0370-2-2-140HA04-HP765	30421835
3,80	6	66	26	22	36	SCD351-0380-2-2-140HA04-HP765	30421836
3,90	6	66	26	22	36	SCD351-0390-2-2-140HA04-HP765	30421837
4,00	6	66	26	22	36	SCD351-0400-2-2-140HA04-HP765	30421838
4,10	6	66	26	22	36	SCD351-0410-2-2-140HA04-HP765	30421839
4,20	6	66	26	22	36	SCD351-0420-2-2-140HA04-HP765	30421840
4,30	6	66	26	22	36	SCD351-0430-2-2-140HA04-HP765	30421842
4,40	6	66	26	22	36	SCD351-0440-2-2-140HA04-HP765	30421843
4,50	6	66	26	22	36	SCD351-0450-2-2-140HA04-HP765	30421844
4,60	6	66	26	22	36	SCD351-0460-2-2-140HA04-HP765	30421845
4,65*	6	66	26	22	36	SCD351-0465-2-2-140HA04-HP765	30421846
4,70	6	66	26	22	36	SCD351-0470-2-2-140HA04-HP765	30421847
4,80	6	66	30	24	36	SCD351-0480-2-2-140HA04-HP765	30421848
4,90	6	66	30	24	36	SCD351-0490-2-2-140HA04-HP765	30421849
5,00	6	66	30	24	36	SCD351-0500-2-2-140HA04-HP765	30421850
5,10	6	66	30	24	36	SCD351-0510-2-2-140HA04-HP765	30421851
5,20	6	66	30	24	36	SCD351-0520-2-2-140HA04-HP765	30421852
5,30	6	66	30	24	36	SCD351-0530-2-2-140HA04-HP765	30421853
5,40	6	66	30	24	36	SCD351-0540-2-2-140HA04-HP765	30421854
5,50	6	66	30	24	36	SCD351-0550-2-2-140HA04-HP765	30421855
5,55*	6	66	30	24	36	SCD351-0555-2-2-140HA04-HP765	30421856
5,60	6	66	30	24	36	SCD351-0560-2-2-140HA04-HP765	30421857
5,70	6	66	30	24	36	SCD351-0570-2-2-140HA04-HP765	30421858
5,80	6	66	30	24	36	SCD351-0580-2-2-140HA04-HP765	30421859
5,90	6	66	30	24	36	SCD351-0590-2-2-140HA04-HP765	30421860
6,00	6	66	30	24	36	SCD351-0600-2-2-140HA04-HP765	30421861
6,10	8	79	38	30	36	SCD351-0610-2-2-140HA04-HP765	30421862

ECU-Drill-Uni | Punta elicoidale in metallo duro integrale SCD351 (4xD), adduzione interna del refrigerante

Dimensioni						Forma del codolo HA	
d ₁ m7	d ₂ h6	l ₁	l ₂	l ₃	l ₄	Specifiche	Codice
6,20	8	79	38	30	36	SCD351-0620-2-2-140HA04-HP765	30421863
6,30	8	79	38	30	36	SCD351-0630-2-2-140HA04-HP765	30421864
6,40	8	79	38	30	36	SCD351-0640-2-2-140HA04-HP765	30421865
6,50	8	79	38	30	36	SCD351-0650-2-2-140HA04-HP765	30421866
6,60	8	79	38	30	36	SCD351-0660-2-2-140HA04-HP765	30421867
6,70	8	79	38	30	36	SCD351-0670-2-2-140HA04-HP765	30421868
6,80	8	79	38	30	36	SCD351-0680-2-2-140HA04-HP765	30421869
6,90	8	79	38	30	36	SCD351-0690-2-2-140HA04-HP765	30421870
7,00	8	79	38	30	36	SCD351-0700-2-2-140HA04-HP765	30421871
7,10	8	79	42	34	36	SCD351-0710-2-2-140HA04-HP765	30421872
7,20	8	79	42	34	36	SCD351-0720-2-2-140HA04-HP765	30421873
7,30	8	79	42	34	36	SCD351-0730-2-2-140HA04-HP765	30421874
7,40	8	79	42	34	36	SCD351-0740-2-2-140HA04-HP765	30421875
7,45*	8	79	42	34	36	SCD351-0745-2-2-140HA04-HP765	30569196
7,50	8	79	42	34	36	SCD351-0750-2-2-140HA04-HP765	30421876
7,60	8	79	42	34	36	SCD351-0760-2-2-140HA04-HP765	30421878
7,70	8	79	42	34	36	SCD351-0770-2-2-140HA04-HP765	30421879
7,80	8	79	42	34	36	SCD351-0780-2-2-140HA04-HP765	30421880
7,90	8	79	42	34	36	SCD351-0790-2-2-140HA04-HP765	30421881
8,00	8	79	42	34	36	SCD351-0800-2-2-140HA04-HP765	30421882
8,10	10	89	49	38	40	SCD351-0810-2-2-140HA04-HP765	30421883
8,20	10	89	49	38	40	SCD351-0820-2-2-140HA04-HP765	30421884
8,30	10	89	49	38	40	SCD351-0830-2-2-140HA04-HP765	30421885
8,40	10	89	49	38	40	SCD351-0840-2-2-140HA04-HP765	30421886
8,50	10	89	49	38	40	SCD351-0850-2-2-140HA04-HP765	30421887
8,60	10	89	49	38	40	SCD351-0860-2-2-140HA04-HP765	30421888
8,70	10	89	49	38	40	SCD351-0870-2-2-140HA04-HP765	30421889
8,80	10	89	49	38	40	SCD351-0880-2-2-140HA04-HP765	30421890
8,90	10	89	49	38	40	SCD351-0890-2-2-140HA04-HP765	30421891
9,00	10	89	49	38	40	SCD351-0900-2-2-140HA04-HP765	30421892
9,10	10	89	49	38	40	SCD351-0910-2-2-140HA04-HP765	30421893
9,20	10	89	49	38	40	SCD351-0920-2-2-140HA04-HP765	30421894
9,30*	10	89	49	40	40	SCD351-0930-2-2-140HA04-HP765	30421896
9,40	10	89	49	40	40	SCD351-0940-2-2-140HA04-HP765	30421897
9,50	10	89	49	40	40	SCD351-0950-2-2-140HA04-HP765	30421898
9,60	10	89	49	40	40	SCD351-0960-2-2-140HA04-HP765	30421899
9,70	10	89	49	40	40	SCD351-0970-2-2-140HA04-HP765	30421900
9,80	10	89	49	40	40	SCD351-0980-2-2-140HA04-HP765	30421901
9,90	10	89	49	40	40	SCD351-0990-2-2-140HA04-HP765	30421902
10,00	10	89	49	40	40	SCD351-1000-2-2-140HA04-HP765	30421903
10,10	12	102	56	45	45	SCD351-1010-2-2-140HA04-HP765	30421904
10,20	12	102	56	45	45	SCD351-1020-2-2-140HA04-HP765	30421905
10,30	12	102	56	45	45	SCD351-1030-2-2-140HA04-HP765	30421906
10,40	12	102	56	45	45	SCD351-1040-2-2-140HA04-HP765	30421907
10,50	12	102	56	45	45	SCD351-1050-2-2-140HA04-HP765	30421908
10,60	12	102	56	45	45	SCD351-1060-2-2-140HA04-HP765	30421909
10,70	12	102	56	45	45	SCD351-1070-2-2-140HA04-HP765	30421910
10,80	12	102	56	45	45	SCD351-1080-2-2-140HA04-HP765	30421911
10,90	12	102	56	45	45	SCD351-1090-2-2-140HA04-HP765	30421912
11,00	12	102	56	45	45	SCD351-1100-2-2-140HA04-HP765	30421913
11,10	12	102	56	45	45	SCD351-1110-2-2-140HA04-HP765	30421914
11,20*	12	102	56	45	45	SCD351-1120-2-2-140HA04-HP765	30421915
11,50	12	102	56	45	45	SCD351-1150-2-2-140HA04-HP765	30421918
11,70	12	102	56	45	45	SCD351-1170-2-2-140HA04-HP765	30421920
11,80	12	102	56	45	45	SCD351-1180-2-2-140HA04-HP765	30421921

Prosegue alla pagina seguente.

ECU-Drill-Uni | Punta elicoidale in metallo duro integrale SCD351 (4xD), adduzione interna del refrigerante

Dimensioni						Forma del codolo HA	
d ₁ m7	d ₂ h6	l ₁	l ₂	l ₃	l ₄	Specifiche	Codice
11,90	12	102	56	45	45	SCD351-1190-2-2-140HA04-HP765	30421922
12,00	12	102	56	45	45	SCD351-1200-2-2-140HA04-HP765	30421923
12,20	14	107	61	50	45	SCD351-1220-2-2-140HA04-HP765	30421924
12,50	14	107	61	50	45	SCD351-1250-2-2-140HA04-HP765	30421925
12,70	14	107	61	50	45	SCD351-1270-2-2-140HA04-HP765	30421926
12,80	14	107	61	50	45	SCD351-1280-2-2-140HA04-HP765	30421927
13,00	14	107	61	50	45	SCD351-1300-2-2-140HA04-HP765	30421928
13,50	14	107	61	50	45	SCD351-1350-2-2-140HA04-HP765	30421929
13,80	14	107	61	50	45	SCD351-1380-2-2-140HA04-HP765	30421931
14,00	14	107	61	50	45	SCD351-1400-2-2-140HA04-HP765	30421932
14,20	16	115	65	51	48	SCD351-1420-2-2-140HA04-HP765	30421934
14,50	16	115	65	51	48	SCD351-1450-2-2-140HA04-HP765	30421935
14,80	16	115	65	51	48	SCD351-1480-2-2-140HA04-HP765	30421936
15,00	16	115	65	51	48	SCD351-1500-2-2-140HA04-HP765	30421937
15,10	16	115	65	51	48	SCD351-1510-2-2-140HA04-HP765	30421938
15,20	16	115	65	51	48	SCD351-1520-2-2-140HA04-HP765	30421939
15,50	16	115	65	51	48	SCD351-1550-2-2-140HA04-HP765	30421941
15,70	16	115	65	51	48	SCD351-1570-2-2-140HA04-HP765	30421942
15,80	16	115	65	51	48	SCD351-1580-2-2-140HA04-HP765	30421943
16,00	16	115	65	51	48	SCD351-1600-2-2-140HA04-HP765	30421944
16,50	18	123	73	53	48	SCD351-1650-2-2-140HA04-HP765	30421946
16,80	18	123	73	53	48	SCD351-1680-2-2-140HA04-HP765	30569199
17,00	18	123	73	53	48	SCD351-1700-2-2-140HA04-HP765	30421947
17,30	18	123	73	53	48	SCD351-1730-2-2-140HA04-HP765	30421949
17,50	18	123	73	53	48	SCD351-1750-2-2-140HA04-HP765	30421950
17,70	18	123	73	53	48	SCD351-1770-2-2-140HA04-HP765	30421951
18,00	18	123	73	53	48	SCD351-1800-2-2-140HA04-HP765	30421952
18,50	20	131	79	55	50	SCD351-1850-2-2-140HA04-HP765	30421953
19,00	20	131	79	55	50	SCD351-1900-2-2-140HA04-HP765	30421954
19,50	20	131	79	55	50	SCD351-1950-2-2-140HA04-HP765	30421956
20,00	20	131	79	55	50	SCD351-2000-2-2-140HA04-HP765	30421957

Caratteristiche configurabili



Forma del codolo:
Forma del codolo: HB | HE

**Specifiche:**

SCD351-0430-3-3-140[forma del codolo]04-HP765

Esempio:

SCD351-0430-3-3-140HE04-HP765

Forma del codolo HE

Misure in mm.

* Specifica per la prefabbricazione di fori da maschiare per maschi a filettare.

Per i parametri di lavorazione consigliati, vedere la fine del capitolo.

Versioni speciali e altri rivestimenti disponibili su richiesta.

ECU-Drill-Uni

Punta elicoidale in metallo duro integrale
SCD350 (4xD), adduzione esterna del refrigerante

Versione:

Diametro punta: 3,00 - 20,00 mm
Tolleranza di foratura: \geq IT 9
Materiale da taglio: HP765
Numero di taglienti: 2
Angolo tra taglienti: 140°
Angolo dell'elica: 30°

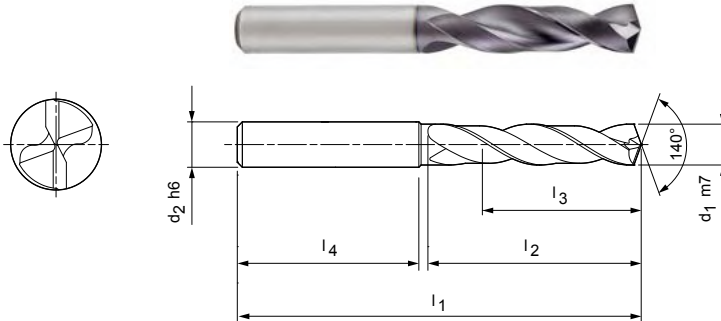

Serie selezionata per il magazzino con forma del codolo HA

Dimensioni						Forma del codolo HA	
d ₁ m7	d ₂ h6	l ₁	l ₂	l ₃	l ₄	Specifiche	Codice
3,00	6	62	22	16	36	SCD350-0300-2-2-140HA04-HP765	30421694
3,10	6	62	22	16	36	SCD350-0310-2-2-140HA04-HP765	30421696
3,20	6	62	22	16	36	SCD350-0320-2-2-140HA04-HP765	30421697
3,30	6	62	22	16	36	SCD350-0330-2-2-140HA04-HP765	30421698
3,40	6	62	22	16	36	SCD350-0340-2-2-140HA04-HP765	30421699
3,50	6	62	22	16	36	SCD350-0350-2-2-140HA04-HP765	30421700
3,60	6	62	22	16	36	SCD350-0360-2-2-140HA04-HP765	30421701
3,70*	6	62	22	16	36	SCD350-0370-2-2-140HA04-HP765	30421703
3,80	6	66	26	22	36	SCD350-0380-2-2-140HA04-HP765	30421704
3,90	6	66	26	22	36	SCD350-0390-2-2-140HA04-HP765	30421705
4,00	6	66	26	22	36	SCD350-0400-2-2-140HA04-HP765	30421706
4,10	6	66	26	22	36	SCD350-0410-2-2-140HA04-HP765	30421707
4,20	6	66	26	22	36	SCD350-0420-2-2-140HA04-HP765	30421708
4,30	6	66	26	22	36	SCD350-0430-2-2-140HA04-HP765	30421709
4,40	6	66	26	22	36	SCD350-0440-2-2-140HA04-HP765	30421710
4,50	6	66	26	22	36	SCD350-0450-2-2-140HA04-HP765	30421711
4,60	6	66	26	22	36	SCD350-0460-2-2-140HA04-HP765	30421712
4,65*	6	66	26	22	36	SCD350-0465-2-2-140HA04-HP765	30421713
4,70	6	66	26	22	36	SCD350-0470-2-2-140HA04-HP765	30421714
4,80	6	66	30	24	36	SCD350-0480-2-2-140HA04-HP765	30421715
4,90	6	66	30	24	36	SCD350-0490-2-2-140HA04-HP765	30421716
5,00	6	66	30	24	36	SCD350-0500-2-2-140HA04-HP765	30421717
5,10	6	66	30	24	36	SCD350-0510-2-2-140HA04-HP765	30421718
5,20	6	66	30	24	36	SCD350-0520-2-2-140HA04-HP765	30421719
5,30	6	66	30	24	36	SCD350-0530-2-2-140HA04-HP765	30421720
5,40	6	66	30	24	36	SCD350-0540-2-2-140HA04-HP765	30421721
5,50	6	66	30	24	36	SCD350-0550-2-2-140HA04-HP765	30421722
5,55*	6	66	30	24	36	SCD350-0555-2-2-140HA04-HP765	30421723
5,60	6	66	30	24	36	SCD350-0560-2-2-140HA04-HP765	30421725
5,70	6	66	30	24	36	SCD350-0570-2-2-140HA04-HP765	30421726
5,80	6	66	30	24	36	SCD350-0580-2-2-140HA04-HP765	30421727
5,90	6	66	30	24	36	SCD350-0590-2-2-140HA04-HP765	30421728
6,00	6	66	30	24	36	SCD350-0600-2-2-140HA04-HP765	30421731
6,10	8	79	38	30	36	SCD350-0610-2-2-140HA04-HP765	30421732

ECU-Drill-Uni | Punta elicoidale in metallo duro integrale SCD350 (4xD), adduzione esterna del refrigerante

Dimensioni						Forma del codolo HA	
d ₁ m7	d ₂ h6	l ₁	l ₂	l ₃	l ₄	Specifiche	Codice
6,20	8	79	38	30	36	SCD350-0620-2-2-140HA04-HP765	30421733
6,30	8	79	38	30	36	SCD350-0630-2-2-140HA04-HP765	30421734
6,40	8	79	38	30	36	SCD350-0640-2-2-140HA04-HP765	30421735
6,50	8	79	38	30	36	SCD350-0650-2-2-140HA04-HP765	30421736
6,60	8	79	38	30	36	SCD350-0660-2-2-140HA04-HP765	30421737
6,70	8	79	38	30	36	SCD350-0670-2-2-140HA04-HP765	30421738
6,80	8	79	38	30	36	SCD350-0680-2-2-140HA04-HP765	30421739
6,90	8	79	38	30	36	SCD350-0690-2-2-140HA04-HP765	30421740
7,00	8	79	38	30	36	SCD350-0700-2-2-140HA04-HP765	30421741
7,10	8	79	42	34	36	SCD350-0710-2-2-140HA04-HP765	30421742
7,20	8	79	42	34	36	SCD350-0720-2-2-140HA04-HP765	30421743
7,30	8	79	42	34	36	SCD350-0730-2-2-140HA04-HP765	30421744
7,40	8	79	42	34	36	SCD350-0740-2-2-140HA04-HP765	30421745
7,50	8	79	42	34	36	SCD350-0750-2-2-140HA04-HP765	30421746
7,60	8	79	42	34	36	SCD350-0760-2-2-140HA04-HP765	30421748
7,70	8	79	42	34	36	SCD350-0770-2-2-140HA04-HP765	30421749
7,80	8	79	42	34	36	SCD350-0780-2-2-140HA04-HP765	30421750
7,90	8	79	42	34	36	SCD350-0790-2-2-140HA04-HP765	30421751
8,00	8	79	42	34	36	SCD350-0800-2-2-140HA04-HP765	30421752
8,10	10	89	49	38	40	SCD350-0810-2-2-140HA04-HP765	30421753
8,20	10	89	49	38	40	SCD350-0820-2-2-140HA04-HP765	30421754
8,30	10	89	49	38	40	SCD350-0830-2-2-140HA04-HP765	30421755
8,40	10	89	49	38	40	SCD350-0840-2-2-140HA04-HP765	30421756
8,50	10	89	49	38	40	SCD350-0850-2-2-140HA04-HP765	30421757
8,60	10	89	49	38	40	SCD350-0860-2-2-140HA04-HP765	30421758
8,70	10	89	49	38	40	SCD350-0870-2-2-140HA04-HP765	30421759
8,80	10	89	49	38	40	SCD350-0880-2-2-140HA04-HP765	30421760
8,90	10	89	49	38	40	SCD350-0890-2-2-140HA04-HP765	30421761
9,00	10	89	49	38	40	SCD350-0900-2-2-140HA04-HP765	30421762
9,10	10	89	49	38	40	SCD350-0910-2-2-140HA04-HP765	30421763
9,20	10	89	49	38	40	SCD350-0920-2-2-140HA04-HP765	30421764
9,30*	10	89	49	40	40	SCD350-0930-2-2-140HA04-HP765	30421766
9,40	10	89	49	40	40	SCD350-0940-2-2-140HA04-HP765	30421767
9,50	10	89	49	40	40	SCD350-0950-2-2-140HA04-HP765	30421768
9,60	10	89	49	40	40	SCD350-0960-2-2-140HA04-HP765	30421769
9,70	10	89	49	40	40	SCD350-0970-2-2-140HA04-HP765	30421770
9,80	10	89	49	40	40	SCD350-0980-2-2-140HA04-HP765	30421771
9,90	10	89	49	40	40	SCD350-0990-2-2-140HA04-HP765	30421772
10,00	10	89	49	40	40	SCD350-1000-2-2-140HA04-HP765	30421773
10,10	12	102	56	45	45	SCD350-1010-2-2-140HA04-HP765	30421774
10,20	12	102	56	45	45	SCD350-1020-2-2-140HA04-HP765	30421775
10,30	12	102	56	45	45	SCD350-1030-2-2-140HA04-HP765	30421776
10,40	12	102	56	45	45	SCD350-1040-2-2-140HA04-HP765	30421777
10,50	12	102	56	45	45	SCD350-1050-2-2-140HA04-HP765	30421778
10,60	12	102	56	45	45	SCD350-1060-2-2-140HA04-HP765	30421779
10,80	12	102	56	45	45	SCD350-1080-2-2-140HA04-HP765	30421781
10,90	12	102	56	45	45	SCD350-1090-2-2-140HA04-HP765	30421782
11,00	12	102	56	45	45	SCD350-1100-2-2-140HA04-HP765	30421783
11,10	12	102	56	45	45	SCD350-1110-2-2-140HA04-HP765	30421784
11,20*	12	102	56	45	45	SCD350-1120-2-2-140HA04-HP765	30421785
11,30	12	102	56	45	45	SCD350-1130-2-2-140HA04-HP765	30421786
11,40	12	102	56	45	45	SCD350-1140-2-2-140HA04-HP765	30421787
11,50	12	102	56	45	45	SCD350-1150-2-2-140HA04-HP765	30421788
11,60	12	102	56	45	45	SCD350-1160-2-2-140HA04-HP765	30421789
11,70	12	102	56	45	45	SCD350-1170-2-2-140HA04-HP765	30421790

ECU-Drill-Uni | Punta elicoidale in metallo duro integrale SCD350 (4xD), adduzione esterna del refrigerante

Dimensioni						Forma del codolo HA	
d ₁ m7	d ₂ h6	l ₁	l ₂	l ₃	l ₄	Specifiche	Codice
11,80	12	102	56	45	45	SCD350-1180-2-2-140HA04-HP765	30421791
12,00	12	102	56	45	45	SCD350-1200-2-2-140HA04-HP765	30421793
12,20	14	107	61	50	45	SCD350-1220-2-2-140HA04-HP765	30421794
12,50	14	107	61	50	45	SCD350-1250-2-2-140HA04-HP765	30421795
12,80	14	107	61	50	45	SCD350-1280-2-2-140HA04-HP765	30421798
13,00	14	107	61	50	45	SCD350-1300-2-2-140HA04-HP765	30421799
13,50	14	107	61	50	45	SCD350-1350-2-2-140HA04-HP765	30421800
13,80	14	107	61	50	45	SCD350-1380-2-2-140HA04-HP765	30421802
14,00	14	107	61	50	45	SCD350-1400-2-2-140HA04-HP765	30421803
14,20	16	115	65	51	48	SCD350-1420-2-2-140HA04-HP765	30421804
14,50	16	115	65	51	48	SCD350-1450-2-2-140HA04-HP765	30421805
14,80	16	115	65	51	48	SCD350-1480-2-2-140HA04-HP765	30421807
15,00	16	115	65	51	48	SCD350-1500-2-2-140HA04-HP765	30421808
15,10	16	115	65	51	48	SCD350-1510-2-2-140HA04-HP765	30421809
15,20	16	115	65	51	48	SCD350-1520-2-2-140HA04-HP765	30421810
15,50	16	115	65	51	48	SCD350-1550-2-2-140HA04-HP765	30421811
15,70	16	115	65	51	48	SCD350-1570-2-2-140HA04-HP765	30421813
15,80	16	115	65	51	48	SCD350-1580-2-2-140HA04-HP765	30421814
16,00	16	115	65	51	48	SCD350-1600-2-2-140HA04-HP765	30421815
16,50	18	123	73	53	48	SCD350-1650-2-2-140HA04-HP765	30421817
17,00	18	123	73	53	48	SCD350-1700-2-2-140HA04-HP765	30421818
17,50	18	123	73	53	48	SCD350-1750-2-2-140HA04-HP765	30421820
17,70	18	123	73	53	48	SCD350-1770-2-2-140HA04-HP765	30421821
18,00	18	123	73	53	48	SCD350-1800-2-2-140HA04-HP765	30421822
18,50	20	131	79	55	50	SCD350-1850-2-2-140HA04-HP765	30421823
19,00	20	131	79	55	50	SCD350-1900-2-2-140HA04-HP765	30421824
19,50	20	131	79	55	50	SCD350-1950-2-2-140HA04-HP765	30421826
20,00	20	131	79	55	50	SCD350-2000-2-2-140HA04-HP765	30421827

Caratteristiche configurabili



Forma del codolo:

Forma del codolo: HB | HE



Specifiche:

SCD350-0430-3-3-140[forma del codolo]04-HP765

Esempio:

SCD350-0430-3-3-140HE04-HP765

Forma del codolo HE

Misure in mm.

* Specifica per la prefabbricazione di fori da maschiare per maschi a filettare.

Per i parametri di lavorazione consigliati, vedere la fine del capitolo.

Versioni speciali e altri rivestimenti disponibili su richiesta.

ECU-Drill-Uni

Punta elicoidale in metallo duro integrale
SCD351 (6xD), adduzione interna del refrigerante

Versione:

Diametro punta: 3,00 - 20,00 mm
Tolleranza di foratura: \geq IT 9
Materiale da taglio: HP765
Numero di taglienti: 2
Angolo tra taglienti: 140°
Angolo dell'elica: 30°

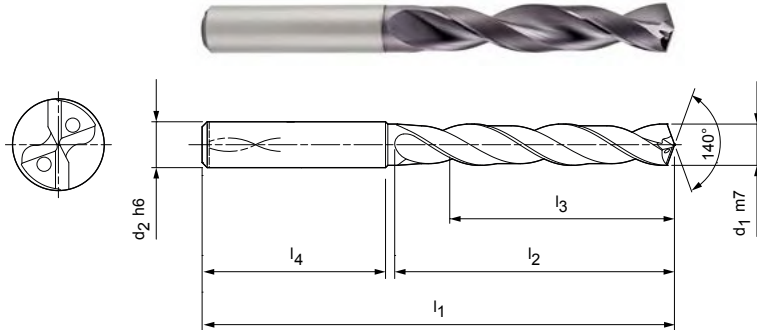

Serie selezionata per il magazzino con forma del codolo HA

Dimensioni						Forma del codolo HA	
d ₁ m7	d ₂ h6	l ₁	l ₂	l ₃	l ₄	Specifiche	Codice
3,00	6	66	28	23	36	SCD351-0300-2-2-140HA06-HP765	30421958
3,10	6	66	28	23	36	SCD351-0310-2-2-140HA06-HP765	30421959
3,20	6	66	28	23	36	SCD351-0320-2-2-140HA06-HP765	30421960
3,30	6	66	28	23	36	SCD351-0330-2-2-140HA06-HP765	30421961
3,40	6	66	28	23	36	SCD351-0340-2-2-140HA06-HP765	30421962
3,50	6	66	28	23	36	SCD351-0350-2-2-140HA06-HP765	30421963
3,60	6	66	28	23	36	SCD351-0360-2-2-140HA06-HP765	30421964
3,70*	6	66	28	23	36	SCD351-0370-2-2-140HA06-HP765	30421965
3,80	6	74	36	29	36	SCD351-0380-2-2-140HA06-HP765	30421966
3,90	6	74	36	29	36	SCD351-0390-2-2-140HA06-HP765	30421967
4,00	6	74	36	29	36	SCD351-0400-2-2-140HA06-HP765	30421968
4,10	6	74	36	29	36	SCD351-0410-2-2-140HA06-HP765	30421969
4,20	6	74	36	29	36	SCD351-0420-2-2-140HA06-HP765	30421970
4,30	6	74	36	29	36	SCD351-0430-2-2-140HA06-HP765	30421971
4,40	6	74	36	29	36	SCD351-0440-2-2-140HA06-HP765	30421972
4,50	6	74	36	29	36	SCD351-0450-2-2-140HA06-HP765	30421973
4,60	6	74	36	29	36	SCD351-0460-2-2-140HA06-HP765	30421974
4,65*	6	74	36	29	36	SCD351-0465-2-2-140HA06-HP765	30421975
4,70	6	74	36	29	36	SCD351-0470-2-2-140HA06-HP765	30421976
4,80	6	82	44	35	36	SCD351-0480-2-2-140HA06-HP765	30421977
4,90	6	82	44	35	36	SCD351-0490-2-2-140HA06-HP765	30421978
5,00	6	82	44	35	36	SCD351-0500-2-2-140HA06-HP765	30421979
5,10	6	82	44	35	36	SCD351-0510-2-2-140HA06-HP765	30421980
5,20	6	82	44	35	36	SCD351-0520-2-2-140HA06-HP765	30421981
5,30	6	82	44	35	36	SCD351-0530-2-2-140HA06-HP765	30421982
5,40	6	82	44	35	36	SCD351-0540-2-2-140HA06-HP765	30421983
5,50	6	82	44	35	36	SCD351-0550-2-2-140HA06-HP765	30421984
5,55*	6	82	44	35	36	SCD351-0555-2-2-140HA06-HP765	30421985
5,60	6	82	44	35	36	SCD351-0560-2-2-140HA06-HP765	30421987
5,70	6	82	44	35	36	SCD351-0570-2-2-140HA06-HP765	30421988
5,80	6	82	44	35	36	SCD351-0580-2-2-140HA06-HP765	30421989
5,90	6	82	44	35	36	SCD351-0590-2-2-140HA06-HP765	30421990
6,00	6	82	44	35	36	SCD351-0600-2-2-140HA06-HP765	30421991
6,10	8	91	53	43	36	SCD351-0610-2-2-140HA06-HP765	30421992
6,20	8	91	53	43	36	SCD351-0620-2-2-140HA06-HP765	30421993

ECU-Drill-Uni | Punta elicoidale in metallo duro integrale SCD351 (6xD), adduzione interna del refrigerante

Dimensioni						Forma del codolo HA	
d ₁ m7	d ₂ h6	l ₁	l ₂	l ₃	l ₄	Specifiche	Codice
6,30	8	91	53	43	36	SCD351-0630-2-2-140HA06-HP765	30421994
6,40	8	91	53	43	36	SCD351-0640-2-2-140HA06-HP765	30421995
6,50	8	91	53	43	36	SCD351-0650-2-2-140HA06-HP765	30421996
6,60	8	91	53	43	36	SCD351-0660-2-2-140HA06-HP765	30421997
6,70	8	91	53	43	36	SCD351-0670-2-2-140HA06-HP765	30421998
6,80	8	91	53	43	36	SCD351-0680-2-2-140HA06-HP765	30421999
6,90	8	91	53	43	36	SCD351-0690-2-2-140HA06-HP765	30422000
7,00	8	91	53	43	36	SCD351-0700-2-2-140HA06-HP765	30422001
7,10	8	91	53	43	36	SCD351-0710-2-2-140HA06-HP765	30422002
7,20	8	91	53	43	36	SCD351-0720-2-2-140HA06-HP765	30422003
7,30	8	91	53	43	36	SCD351-0730-2-2-140HA06-HP765	30422004
7,40	8	91	53	43	36	SCD351-0740-2-2-140HA06-HP765	30422005
7,45*	8	91	53	43	36	SCD351-0745-2-2-140HA06-HP765	30569230
7,50	8	91	53	43	36	SCD351-0750-2-2-140HA06-HP765	30422006
7,60	8	91	53	43	36	SCD351-0760-2-2-140HA06-HP765	30422008
7,70	8	91	53	43	36	SCD351-0770-2-2-140HA06-HP765	30422009
7,80	8	91	53	43	36	SCD351-0780-2-2-140HA06-HP765	30422010
7,90	8	91	53	43	36	SCD351-0790-2-2-140HA06-HP765	30422011
8,00	8	91	53	43	36	SCD351-0800-2-2-140HA06-HP765	30422012
8,10	10	103	61	49	40	SCD351-0810-2-2-140HA06-HP765	30422013
8,20	10	103	61	49	40	SCD351-0820-2-2-140HA06-HP765	30422014
8,30	10	103	61	49	40	SCD351-0830-2-2-140HA06-HP765	30422015
8,40	10	103	61	49	40	SCD351-0840-2-2-140HA06-HP765	30422016
8,50	10	103	61	49	40	SCD351-0850-2-2-140HA06-HP765	30422017
8,60	10	103	61	49	40	SCD351-0860-2-2-140HA06-HP765	30422018
8,70	10	103	61	49	40	SCD351-0870-2-2-140HA06-HP765	30422019
8,80	10	103	61	49	40	SCD351-0880-2-2-140HA06-HP765	30422020
8,90	10	103	61	49	40	SCD351-0890-2-2-140HA06-HP765	30422021
9,00	10	103	61	49	40	SCD351-0900-2-2-140HA06-HP765	30422022
9,10	10	103	61	49	40	SCD351-0910-2-2-140HA06-HP765	30422023
9,20	10	103	61	49	40	SCD351-0920-2-2-140HA06-HP765	30422024
9,30*	10	103	61	49	40	SCD351-0930-2-2-140HA06-HP765	30422026
9,40	10	103	61	49	40	SCD351-0940-2-2-140HA06-HP765	30422027
9,50	10	103	61	49	40	SCD351-0950-2-2-140HA06-HP765	30422028
9,60	10	103	61	49	40	SCD351-0960-2-2-140HA06-HP765	30422029
9,70	10	103	61	49	40	SCD351-0970-2-2-140HA06-HP765	30422030
9,80	10	103	61	49	40	SCD351-0980-2-2-140HA06-HP765	30422031
9,90	10	103	61	49	40	SCD351-0990-2-2-140HA06-HP765	30422032
10,00	10	103	61	49	40	SCD351-1000-2-2-140HA06-HP765	30422033
10,10	12	118	71	56	45	SCD351-1010-2-2-140HA06-HP765	30422034
10,20	12	118	71	56	45	SCD351-1020-2-2-140HA06-HP765	30422035
10,30	12	118	71	56	45	SCD351-1030-2-2-140HA06-HP765	30422036
10,40	12	118	71	56	45	SCD351-1040-2-2-140HA06-HP765	30422037
10,50	12	118	71	56	45	SCD351-1050-2-2-140HA06-HP765	30422038
10,60	12	118	71	56	45	SCD351-1060-2-2-140HA06-HP765	30422039
10,70	12	118	71	56	45	SCD351-1070-2-2-140HA06-HP765	30422040
10,80	12	118	71	56	45	SCD351-1080-2-2-140HA06-HP765	30422041
10,90	12	118	71	56	45	SCD351-1090-2-2-140HA06-HP765	30422042
11,00	12	118	71	56	45	SCD351-1100-2-2-140HA06-HP765	30422043
11,10	12	118	71	56	45	SCD351-1110-2-2-140HA06-HP765	30422044
11,20*	12	118	71	56	45	SCD351-1120-2-2-140HA06-HP765	30422045
11,30	12	118	71	56	45	SCD351-1130-2-2-140HA06-HP765	30422046
11,50	12	118	71	56	45	SCD351-1150-2-2-140HA06-HP765	30422048
11,60	12	118	71	56	45	SCD351-1160-2-2-140HA06-HP765	30422049
11,80	12	118	71	56	45	SCD351-1180-2-2-140HA06-HP765	30422051
11,90	12	118	71	56	45	SCD351-1190-2-2-140HA06-HP765	30422052
12,00	12	118	71	56	45	SCD351-1200-2-2-140HA06-HP765	30422053

Prosegue alla pagina seguente.

ECU-Drill-Uni | Punta elicoidale in metallo duro integrale SCD351 (6xD), adduzione interna del refrigerante

Dimensioni						Forma del codolo HA	
d ₁ m7	d ₂ h6	l ₁	l ₂	l ₃	l ₄	Specifiche	Codice
12,20	14	124	77	60	45	SCD351-1220-2-2-140HA06-HP765	30422054
12,50	14	124	77	60	45	SCD351-1250-2-2-140HA06-HP765	30422055
12,70	14	124	77	60	45	SCD351-1270-2-2-140HA06-HP765	30422056
12,80	14	124	77	60	45	SCD351-1280-2-2-140HA06-HP765	30422057
13,00	14	124	77	60	45	SCD351-1300-2-2-140HA06-HP765	30422058
13,50	14	124	77	60	45	SCD351-1350-2-2-140HA06-HP765	30422059
13,70	14	124	77	60	45	SCD351-1370-2-2-140HA06-HP765	30422060
13,80	14	124	77	60	45	SCD351-1380-2-2-140HA06-HP765	30422061
14,00	14	124	77	60	45	SCD351-1400-2-2-140HA06-HP765	30422062
14,20	16	133	83	63	48	SCD351-1420-2-2-140HA06-HP765	30422063
14,50	16	133	83	63	48	SCD351-1450-2-2-140HA06-HP765	30422064
14,80	16	133	83	63	48	SCD351-1480-2-2-140HA06-HP765	30422066
15,00	16	133	83	63	48	SCD351-1500-2-2-140HA06-HP765	30422067
15,50	16	133	83	63	48	SCD351-1550-2-2-140HA06-HP765	30422069
15,70	16	133	83	63	48	SCD351-1570-2-2-140HA06-HP765	30422070
15,80	16	133	83	63	48	SCD351-1580-2-2-140HA06-HP765	30422071
16,00	16	133	83	63	48	SCD351-1600-2-2-140HA06-HP765	30422072
16,50	18	143	93	71	48	SCD351-1650-2-2-140HA06-HP765	30422073
17,00	18	143	93	71	48	SCD351-1700-2-2-140HA06-HP765	30422074
17,50	18	143	93	71	48	SCD351-1750-2-2-140HA06-HP765	30422075
18,00	18	143	93	71	48	SCD351-1800-2-2-140HA06-HP765	30422076
18,50	20	153	101	77	50	SCD351-1850-2-2-140HA06-HP765	30422077
19,00	20	153	101	77	50	SCD351-1900-2-2-140HA06-HP765	30422078
19,50	20	153	101	77	50	SCD351-1950-2-2-140HA06-HP765	30422079
20,00	20	153	101	77	50	SCD351-2000-2-2-140HA06-HP765	30422080

Caratteristiche configurabili



Forma del codolo:
Forma del codolo: HB | HE

**Specifiche:**

SCD351-0430-3-3-140[forma del codolo]06-HP765

Esempio:

SCD351-0430-3-3-140HE06-HP765

Forma del codolo HE

Misure in mm.

* Specifica per la prefabbricazione di fori da maschiare per maschi a filettare.

Per i parametri di lavorazione consigliati, vedere la fine del capitolo.

Versioni speciali e altri rivestimenti disponibili su richiesta.

MEGA-Drill-Steel-Plus

Punta elicoidale in metallo duro integrale

SCD600 (3xD), adduzione esterna del refrigerante, prodotto successivo a MEGA-Step-Drill-Steel (SCD10)

Versione:

Diametro punta:	3,00 – 25,00 mm
Tolleranza di foratura:	≥ IT 9
Materiale da taglio:	HP358
Numero di taglienti:	2
Numero margini di guida:	2
Angolo tra taglienti:	140°
Angolo dell'elica:	30°

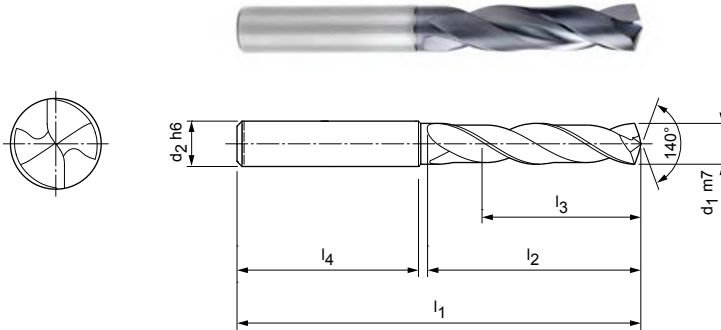

Serie selezionata per il magazzino con forma del codolo HA

Dimensioni						Forma del codolo HA	
d ₁ m7	d ₂ h6	l ₁	l ₂	l ₃	l ₄	Specifiche	Codice
3,00	6	62	20	14	36	SCD600-0300-2-2-140HA03-HP358	30801131
3,10	6	62	20	14	36	SCD600-0310-2-2-140HA03-HP358	30801132
3,15	6	62	20	14	36	SCD600-0315-2-2-140HA03-HP358	30801133
3,20	6	62	20	14	36	SCD600-0320-2-2-140HA03-HP358	30801134
3,25	6	62	20	14	36	SCD600-0325-2-2-140HA03-HP358	30801136
3,30	6	62	20	14	36	SCD600-0330-2-2-140HA03-HP358	30801137
3,40	6	62	20	14	36	SCD600-0340-2-2-140HA03-HP358	30801138
3,50	6	62	20	14	36	SCD600-0350-2-2-140HA03-HP358	30801139
3,60	6	62	20	14	36	SCD600-0360-2-2-140HA03-HP358	30801140
3,70*	6	62	20	14	36	SCD600-0370-2-2-140HA03-HP358	30801141
3,80	6	66	24	17	36	SCD600-0380-2-2-140HA03-HP358	30801142
3,85	6	66	24	17	36	SCD600-0385-2-2-140HA03-HP358	30801143
3,90	6	66	24	17	36	SCD600-0390-2-2-140HA03-HP358	30801144
4,00	6	66	24	17	36	SCD600-0400-2-2-140HA03-HP358	30801145
4,10	6	66	24	17	36	SCD600-0410-2-2-140HA03-HP358	30801146
4,20	6	66	24	17	36	SCD600-0420-2-2-140HA03-HP358	30801147
4,25	6	66	24	17	36	SCD600-0425-2-2-140HA03-HP358	30801148
4,30	6	66	24	17	36	SCD600-0430-2-2-140HA03-HP358	30801149
4,35	6	66	24	17	36	SCD600-0435-2-2-140HA03-HP358	30801150
4,40	6	66	24	17	36	SCD600-0440-2-2-140HA03-HP358	30801151
4,45	6	66	24	17	36	SCD600-0445-2-2-140HA03-HP358	30801152
4,50	6	66	24	17	36	SCD600-0450-2-2-140HA03-HP358	30801153
4,60	6	66	24	17	36	SCD600-0460-2-2-140HA03-HP358	30801154
4,65*	6	66	24	17	36	SCD600-0465-2-2-140HA03-HP358	30801155
4,70	6	66	24	17	36	SCD600-0470-2-2-140HA03-HP358	30801156
4,80	6	66	28	20	36	SCD600-0480-2-2-140HA03-HP358	30801157
4,90	6	66	28	20	36	SCD600-0490-2-2-140HA03-HP358	30801158
4,95	6	66	28	20	36	SCD600-0495-2-2-140HA03-HP358	30801159
5,00	6	66	28	20	36	SCD600-0500-2-2-140HA03-HP358	30801160
5,05	6	66	28	20	36	SCD600-0505-2-2-140HA03-HP358	30801161
5,10	6	66	28	20	36	SCD600-0510-2-2-140HA03-HP358	30801162
5,20	6	66	28	20	36	SCD600-0520-2-2-140HA03-HP358	30801163
5,30	6	66	28	20	36	SCD600-0530-2-2-140HA03-HP358	30801164
5,40	6	66	28	20	36	SCD600-0540-2-2-140HA03-HP358	30801165
5,50	6	66	28	20	36	SCD600-0550-2-2-140HA03-HP358	30801166

MEGA-Drill-Steel-Plus | Punta elicoidale in metallo duro integrale SCD600 (3xD), adduzione esterna del refrigerante

Dimensioni						Forma del codolo HA	
d ₁ m7	d ₂ h6	l ₁	l ₂	l ₃	l ₄	Specifiche	Codice
5,55*	6	66	28	20	36	SCD600-0555-2-2-140HA03-HP358	30801167
5,60	6	66	28	20	36	SCD600-0560-2-2-140HA03-HP358	30801168
5,70	6	66	28	20	36	SCD600-0570-2-2-140HA03-HP358	30801169
5,75	6	66	28	20	36	SCD600-0575-2-2-140HA03-HP358	30801170
5,80	6	66	28	20	36	SCD600-0580-2-2-140HA03-HP358	30801171
5,90	6	66	28	20	36	SCD600-0590-2-2-140HA03-HP358	30801172
5,95	6	66	28	20	36	SCD600-0595-2-2-140HA03-HP358	30801173
6,00	6	66	28	20	36	SCD600-0600-2-2-140HA03-HP358	30801174
6,10	8	79	34	24	36	SCD600-0610-2-2-140HA03-HP358	30801175
6,20	8	79	34	24	36	SCD600-0620-2-2-140HA03-HP358	30801176
6,30	8	79	34	24	36	SCD600-0630-2-2-140HA03-HP358	30801177
6,40	8	79	34	24	36	SCD600-0640-2-2-140HA03-HP358	30801178
6,50	8	79	34	24	36	SCD600-0650-2-2-140HA03-HP358	30801179
6,60	8	79	34	24	36	SCD600-0660-2-2-140HA03-HP358	30801180
6,70	8	79	34	24	36	SCD600-0670-2-2-140HA03-HP358	30801181
6,80	8	79	34	24	36	SCD600-0680-2-2-140HA03-HP358	30801182
6,90	8	79	34	24	36	SCD600-0690-2-2-140HA03-HP358	30801183
7,00	8	79	34	24	36	SCD600-0700-2-2-140HA03-HP358	30801184
7,10	8	79	41	29	36	SCD600-0710-2-2-140HA03-HP358	30801185
7,20	8	79	41	29	36	SCD600-0720-2-2-140HA03-HP358	30801186
7,30	8	79	41	29	36	SCD600-0730-2-2-140HA03-HP358	30801187
7,40	8	79	41	29	36	SCD600-0740-2-2-140HA03-HP358	30801188
7,45*	8	79	41	29	36	SCD600-0745-2-2-140HA03-HP358	30801189
7,50	8	79	41	29	36	SCD600-0750-2-2-140HA03-HP358	30801190
7,60	8	79	41	29	36	SCD600-0760-2-2-140HA03-HP358	30801191
7,70	8	79	41	29	36	SCD600-0770-2-2-140HA03-HP358	30801192
7,80	8	79	41	29	36	SCD600-0780-2-2-140HA03-HP358	30801193
7,90	8	79	41	29	36	SCD600-0790-2-2-140HA03-HP358	30801194
8,00	8	79	41	29	36	SCD600-0800-2-2-140HA03-HP358	30801195
8,10	10	89	47	35	40	SCD600-0810-2-2-140HA03-HP358	30801196
8,20	10	89	47	35	40	SCD600-0820-2-2-140HA03-HP358	30801197
9,10	10	89	47	35	40	SCD600-0910-2-2-140HA03-HP358	30801206
9,20	10	89	47	35	40	SCD600-0920-2-2-140HA03-HP358	30801207
9,30*	10	89	47	35	40	SCD600-0930-2-2-140HA03-HP358	30801208
9,35	10	89	47	35	40	SCD600-0935-2-2-140HA03-HP358	30801209
9,50	10	89	47	35	40	SCD600-0950-2-2-140HA03-HP358	30801212
9,60	10	89	47	35	40	SCD600-0960-2-2-140HA03-HP358	30801213
9,70	10	89	47	35	40	SCD600-0970-2-2-140HA03-HP358	30801214
9,80	10	89	47	35	40	SCD600-0980-2-2-140HA03-HP358	30801215
9,90	10	89	47	35	40	SCD600-0990-2-2-140HA03-HP358	30801216
10,00	10	89	47	35	40	SCD600-1000-2-2-140HA03-HP358	30801217
10,10	12	102	55	40	45	SCD600-1010-2-2-140HA03-HP358	30801218
10,20	12	102	55	40	45	SCD600-1020-2-2-140HA03-HP358	30801219
10,30	12	102	55	40	45	SCD600-1030-2-2-140HA03-HP358	30801220
10,40	12	102	55	40	45	SCD600-1040-2-2-140HA03-HP358	30801221
10,50	12	102	55	40	45	SCD600-1050-2-2-140HA03-HP358	30801222
10,55	12	102	55	40	45	SCD600-1055-2-2-140HA03-HP358	30801223
10,60	12	102	55	40	45	SCD600-1060-2-2-140HA03-HP358	30801224
10,70	12	102	55	40	45	SCD600-1070-2-2-140HA03-HP358	30801225
10,80	12	102	55	40	45	SCD600-1080-2-2-140HA03-HP358	30801227
10,90	12	102	55	40	45	SCD600-1090-2-2-140HA03-HP358	30801228
11,00	12	102	55	40	45	SCD600-1100-2-2-140HA03-HP358	30801229
11,10	12	102	55	40	45	SCD600-1110-2-2-140HA03-HP358	30801230
11,20*	12	102	55	40	45	SCD600-1120-2-2-140HA03-HP358	30801231
11,25	12	102	55	40	45	SCD600-1125-2-2-140HA03-HP358	30801232
11,30	12	102	55	40	45	SCD600-1130-2-2-140HA03-HP358	30801233
11,35	12	102	55	40	45	SCD600-1135-2-2-140HA03-HP358	30801234

MEGA-Drill-Steel-Plus | Punta elicoidale in metallo duro integrale SCD600 (3xD), adduzione esterna del refrigerante

Dimensioni						Forma del codolo HA	
d ₁ m7	d ₂ h6	l ₁	l ₂	l ₃	l ₄	Specifiche	Codice
11,40	12	102	55	40	45	SCD600-1140-2-2-140HA03-HP358	30801235
11,50	12	102	55	40	45	SCD600-1150-2-2-140HA03-HP358	30801237
11,60	12	102	55	40	45	SCD600-1160-2-2-140HA03-HP358	30801238
11,70	12	102	55	40	45	SCD600-1170-2-2-140HA03-HP358	30801239
11,80	12	102	55	40	45	SCD600-1180-2-2-140HA03-HP358	30801240
11,90	12	102	55	40	45	SCD600-1190-2-2-140HA03-HP358	30801241
12,00	12	102	55	40	45	SCD600-1200-2-2-140HA03-HP358	30801242
12,15	14	107	60	43	45	SCD600-1215-2-2-140HA03-HP358	30801243
12,25	14	107	60	43	45	SCD600-1225-2-2-140HA03-HP358	30801244
12,50	14	107	60	43	45	SCD600-1250-2-2-140HA03-HP358	30801245
12,55	14	107	60	43	45	SCD600-1255-2-2-140HA03-HP358	30801246
12,70	14	107	60	43	45	SCD600-1270-2-2-140HA03-HP358	30801247
12,80	14	107	60	43	45	SCD600-1280-2-2-140HA03-HP358	30801248
13,00	14	107	60	43	45	SCD600-1300-2-2-140HA03-HP358	30801250
13,10	14	107	60	43	45	SCD600-1310-2-2-140HA03-HP358	30801251
13,30	14	107	60	43	45	SCD600-1330-2-2-140HA03-HP358	30801252
13,35	14	107	60	43	45	SCD600-1335-2-2-140HA03-HP358	30801253
13,50	14	107	60	43	45	SCD600-1350-2-2-140HA03-HP358	30801254
13,70	14	107	60	43	45	SCD600-1370-2-2-140HA03-HP358	30801255
13,80	14	107	60	43	45	SCD600-1380-2-2-140HA03-HP358	30801256
14,00	14	107	60	43	45	SCD600-1400-2-2-140HA03-HP358	30801257
14,20	16	115	65	45	48	SCD600-1420-2-2-140HA03-HP358	30801258
14,50	16	115	65	45	48	SCD600-1450-2-2-140HA03-HP358	30801259
14,80	16	115	65	45	48	SCD600-1480-2-2-140HA03-HP358	30801260
15,00	16	115	65	45	48	SCD600-1500-2-2-140HA03-HP358	30801261
15,10	16	115	65	45	48	SCD600-1510-2-2-140HA03-HP358	30801262
15,25	16	115	65	45	48	SCD600-1525-2-2-140HA03-HP358	30801263
15,30	16	115	65	45	48	SCD600-1530-2-2-140HA03-HP358	30801264
15,35	16	115	65	45	48	SCD600-1535-2-2-140HA03-HP358	30801265
15,50	16	115	65	45	48	SCD600-1550-2-2-140HA03-HP358	30801266
15,60	16	115	65	45	48	SCD600-1560-2-2-140HA03-HP358	30801267
15,80	16	115	65	45	48	SCD600-1580-2-2-140HA03-HP358	30801268
16,00	16	115	65	45	48	SCD600-1600-2-2-140HA03-HP358	30801269
16,05	18	123	73	51	48	SCD600-1605-2-2-140HA03-HP358	30801270
16,50	18	123	73	51	48	SCD600-1650-2-2-140HA03-HP358	30801271
16,80	18	123	73	51	48	SCD600-1680-2-2-140HA03-HP358	30801272
17,00	18	123	73	51	48	SCD600-1700-2-2-140HA03-HP358	30801274
17,50	18	123	73	51	48	SCD600-1750-2-2-140HA03-HP358	30801275
17,80	18	123	73	51	48	SCD600-1780-2-2-140HA03-HP358	30801277
18,00	18	123	73	51	48	SCD600-1800-2-2-140HA03-HP358	30801278
18,50	20	131	79	55	50	SCD600-1850-2-2-140HA03-HP358	30801279
19,00	20	131	79	55	50	SCD600-1900-2-2-140HA03-HP358	30801282
19,35	20	131	79	55	50	SCD600-1935-2-2-140HA03-HP358	30801283
19,60	20	131	79	55	50	SCD600-1960-2-2-140HA03-HP358	30801285
19,80	20	131	79	55	50	SCD600-1980-2-2-140HA03-HP358	30801286
20,00	20	131	79	55	50	SCD600-2000-2-2-140HA03-HP358	30801287

Prosegue alla pagina seguente.

MEGA-Drill-Steel-Plus | Punta elicoidale in metallo duro integrale SCD600 (3xD), adduzione esterna del refrigerante

Caratteristiche configurabili

**Diametro:**

Diametro a libera scelta a passi da 0,01 mm

**Forma del codolo:**

Forma del codolo: HB | HE

Specifiche:

SCD600-[diametro]-3-3-140[forma del codolo]03-HP358

Dimensioni serie configurabile

d ₁ min.	d ₁ max.	d ₂ h6	l ₁	l ₂	l ₃	l ₄
3,00	3,70	6	62	20	14	36
3,71	4,70	6	66	24	17	36
4,71	6,00	6	66	28	20	36
6,01	7,00	8	79	34	24	36
7,01	8,00	8	79	41	29	36
8,01	10,00	10	89	47	35	40
10,01	12,00	12	102	55	40	45
12,01	14,00	14	107	60	43	45
14,01	16,00	16	115	65	45	48
16,01	18,00	18	123	73	51	48
18,01	20,00	20	131	79	55	50

Esempio:

SCD600-0431-3-3-140HE03-HP358

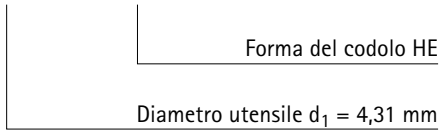

Misure in mm.

* Specifica per la prefabbricazione di fori da maschiare per maschi a filettare.

Per i parametri di lavorazione consigliati, vedere la fine del capitolo.

Versioni speciali e altri rivestimenti disponibili su richiesta.

MEGA-Drill-Steel-Plus

Punta elicoidale in metallo duro integrale

SCD601 (3xD), adduzione interna del refrigerante, prodotto successivo a MEGA-Drill-Steel (SCD10)

Versione:

Diametro punta:	3,00 – 25,00 mm
Tolleranza di foratura:	≥ IT 9
Materiale da taglio:	HP358
Numero di taglienti:	2
Numero margini di guida:	2
Angolo tra taglienti:	140°
Angolo dell'elica:	30°

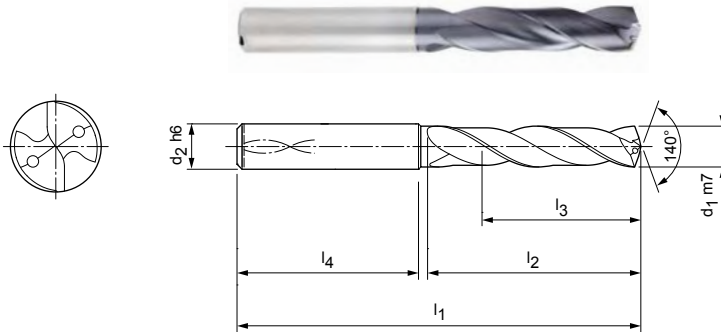

Serie selezionata per il magazzino con forma del codolo HA

Dimensioni						Forma del codolo HA	
d ₁ m7	d ₂ h6	l ₁	l ₂	l ₃	l ₄	Specifiche	Codice
3,00	6	62	20	14	36	SCD601-0300-2-2-140HA03-HP358	30802107
3,10	6	62	20	14	36	SCD601-0310-2-2-140HA03-HP358	30802108
3,15	6	62	20	14	36	SCD601-0315-2-2-140HA03-HP358	30802109
3,20	6	62	20	14	36	SCD601-0320-2-2-140HA03-HP358	30802110
3,22	6	62	20	14	36	SCD601-0322-2-2-140HA03-HP358	30802111
3,25	6	62	20	14	36	SCD601-0325-2-2-140HA03-HP358	30802112
3,30	6	62	20	14	36	SCD601-0330-2-2-140HA03-HP358	30802113
3,40	6	62	20	14	36	SCD601-0340-2-2-140HA03-HP358	30802115
3,50	6	62	20	14	36	SCD601-0350-2-2-140HA03-HP358	30802116
3,60	6	62	20	14	36	SCD601-0360-2-2-140HA03-HP358	30802117
3,70*	6	62	20	14	36	SCD601-0370-2-2-140HA03-HP358	30802118
3,80	6	66	24	17	36	SCD601-0380-2-2-140HA03-HP358	30802119
3,85	6	66	24	17	36	SCD601-0385-2-2-140HA03-HP358	30802120
3,90	6	66	24	17	36	SCD601-0390-2-2-140HA03-HP358	30802121
4,00	6	66	24	17	36	SCD601-0400-2-2-140HA03-HP358	30802122
4,10	6	66	24	17	36	SCD601-0410-2-2-140HA03-HP358	30802123
4,20	6	66	24	17	36	SCD601-0420-2-2-140HA03-HP358	30802124
4,25	6	66	24	17	36	SCD601-0425-2-2-140HA03-HP358	30802125
4,30	6	66	24	17	36	SCD601-0430-2-2-140HA03-HP358	30802126
4,40	6	66	24	17	36	SCD601-0440-2-2-140HA03-HP358	30802129
4,50	6	66	24	17	36	SCD601-0450-2-2-140HA03-HP358	30802131
4,60	6	66	24	17	36	SCD601-0460-2-2-140HA03-HP358	30802132
4,65*	6	66	24	17	36	SCD601-0465-2-2-140HA03-HP358	30802133
4,70	6	66	24	17	36	SCD601-0470-2-2-140HA03-HP358	30802134
4,80	6	66	28	20	36	SCD601-0480-2-2-140HA03-HP358	30802135
4,90	6	66	28	20	36	SCD601-0490-2-2-140HA03-HP358	30802136
4,95	6	66	28	20	36	SCD601-0495-2-2-140HA03-HP358	30802137
5,00	6	66	28	20	36	SCD601-0500-2-2-140HA03-HP358	30802138
5,05	6	66	28	20	36	SCD601-0505-2-2-140HA03-HP358	30802139
5,10	6	66	28	20	36	SCD601-0510-2-2-140HA03-HP358	30802140
5,20	6	66	28	20	36	SCD601-0520-2-2-140HA03-HP358	30802141
5,30	6	66	28	20	36	SCD601-0530-2-2-140HA03-HP358	30802142
5,40	6	66	28	20	36	SCD601-0540-2-2-140HA03-HP358	30802143
5,50	6	66	28	20	36	SCD601-0550-2-2-140HA03-HP358	30802144
5,55*	6	66	28	20	36	SCD601-0555-2-2-140HA03-HP358	30802145

MEGA-Drill-Steel-Plus | Punta elicoidale in metallo duro integrale SCD601 (3xD), adduzione interna del refrigerante

Dimensioni						Forma del codolo HA	
d ₁ m7	d ₂ h6	l ₁	l ₂	l ₃	l ₄	Specifiche	Codice
5,60	6	66	28	20	36	SCD601-0560-2-2-140HA03-HP358	30802146
5,70	6	66	28	20	36	SCD601-0570-2-2-140HA03-HP358	30802147
5,75	6	66	28	20	36	SCD601-0575-2-2-140HA03-HP358	30802148
5,80	6	66	28	20	36	SCD601-0580-2-2-140HA03-HP358	30802149
5,90	6	66	28	20	36	SCD601-0590-2-2-140HA03-HP358	30802150
5,95	6	66	28	20	36	SCD601-0595-2-2-140HA03-HP358	30802151
6,00	6	66	28	20	36	SCD601-0600-2-2-140HA03-HP358	30802152
6,10	8	79	34	24	36	SCD601-0610-2-2-140HA03-HP358	30802153
6,20	8	79	34	24	36	SCD601-0620-2-2-140HA03-HP358	30802154
6,30	8	79	34	24	36	SCD601-0630-2-2-140HA03-HP358	30802155
6,40	8	79	34	24	36	SCD601-0640-2-2-140HA03-HP358	30802156
6,50	8	79	34	24	36	SCD601-0650-2-2-140HA03-HP358	30802157
6,60	8	79	34	24	36	SCD601-0660-2-2-140HA03-HP358	30802158
6,70	8	79	34	24	36	SCD601-0670-2-2-140HA03-HP358	30802159
6,80	8	79	34	24	36	SCD601-0680-2-2-140HA03-HP358	30802160
6,90	8	79	34	24	36	SCD601-0690-2-2-140HA03-HP358	30802161
7,00	8	79	34	24	36	SCD601-0700-2-2-140HA03-HP358	30802162
7,10	8	79	41	29	36	SCD601-0710-2-2-140HA03-HP358	30802163
7,20	8	79	41	29	36	SCD601-0720-2-2-140HA03-HP358	30802164
7,30	8	79	41	29	36	SCD601-0730-2-2-140HA03-HP358	30802165
7,40	8	79	41	29	36	SCD601-0740-2-2-140HA03-HP358	30802166
7,45*	8	79	41	29	36	SCD601-0745-2-2-140HA03-HP358	30802167
7,50	8	79	41	29	36	SCD601-0750-2-2-140HA03-HP358	30802168
7,60	8	79	41	29	36	SCD601-0760-2-2-140HA03-HP358	30802169
7,70	8	79	41	29	36	SCD601-0770-2-2-140HA03-HP358	30802170
7,80	8	79	41	29	36	SCD601-0780-2-2-140HA03-HP358	30802171
7,90	8	79	41	29	36	SCD601-0790-2-2-140HA03-HP358	30802172
8,00	8	79	41	29	36	SCD601-0800-2-2-140HA03-HP358	30802173
8,10	10	89	47	35	40	SCD601-0810-2-2-140HA03-HP358	30802174
8,20	10	89	47	35	40	SCD601-0820-2-2-140HA03-HP358	30802175
8,30	10	89	47	35	40	SCD601-0830-2-2-140HA03-HP358	30802176
8,40	10	89	47	35	40	SCD601-0840-2-2-140HA03-HP358	30802177
8,50	10	89	47	35	40	SCD601-0850-2-2-140HA03-HP358	30802178
8,60	10	89	47	35	40	SCD601-0860-2-2-140HA03-HP358	30802179
8,70	10	89	47	35	40	SCD601-0870-2-2-140HA03-HP358	30802180
8,80	10	89	47	35	40	SCD601-0880-2-2-140HA03-HP358	30802181
8,90	10	89	47	35	40	SCD601-0890-2-2-140HA03-HP358	30802182
9,00	10	89	47	35	40	SCD601-0900-2-2-140HA03-HP358	30802183
9,10	10	89	47	35	40	SCD601-0910-2-2-140HA03-HP358	30802184
9,20	10	89	47	35	40	SCD601-0920-2-2-140HA03-HP358	30802185
9,30*	10	89	47	35	40	SCD601-0930-2-2-140HA03-HP358	30802186
9,35	10	89	47	35	40	SCD601-0935-2-2-140HA03-HP358	30802187
9,40	10	89	47	35	40	SCD601-0940-2-2-140HA03-HP358	30802188
9,50	10	89	47	35	40	SCD601-0950-2-2-140HA03-HP358	30802190
9,60	10	89	47	35	40	SCD601-0960-2-2-140HA03-HP358	30802191
9,70	10	89	47	35	40	SCD601-0970-2-2-140HA03-HP358	30802192
9,80	10	89	47	35	40	SCD601-0980-2-2-140HA03-HP358	30802193
9,90	10	89	47	35	40	SCD601-0990-2-2-140HA03-HP358	30802194
10,00	10	89	47	35	40	SCD601-1000-2-2-140HA03-HP358	30802195
10,10	12	102	55	40	45	SCD601-1010-2-2-140HA03-HP358	30802196
10,20	12	102	55	40	45	SCD601-1020-2-2-140HA03-HP358	30802197
10,30	12	102	55	40	45	SCD601-1030-2-2-140HA03-HP358	30802198
10,40	12	102	55	40	45	SCD601-1040-2-2-140HA03-HP358	30802199
10,50	12	102	55	40	45	SCD601-1050-2-2-140HA03-HP358	30802200
10,55	12	102	55	40	45	SCD601-1055-2-2-140HA03-HP358	30802201
10,60	12	102	55	40	45	SCD601-1060-2-2-140HA03-HP358	30802202
10,70	12	102	55	40	45	SCD601-1070-2-2-140HA03-HP358	30802203

MEGA-Drill-Steel-Plus | Punta elicoidale in metallo duro integrale SCD601 (3xD), adduzione interna del refrigerante

Dimensioni						Forma del codolo HA	
d ₁ m7	d ₂ h6	l ₁	l ₂	l ₃	l ₄	Specifiche	Codice
10,75	12	102	55	40	45	SCD601-1075-2-2-140HA03-HP358	30802204
10,80	12	102	55	40	45	SCD601-1080-2-2-140HA03-HP358	30802205
10,90	12	102	55	40	45	SCD601-1090-2-2-140HA03-HP358	30802206
11,00	12	102	55	40	45	SCD601-1100-2-2-140HA03-HP358	30802207
11,10	12	102	55	40	45	SCD601-1110-2-2-140HA03-HP358	30802208
11,20*	12	102	55	40	45	SCD601-1120-2-2-140HA03-HP358	30802209
11,25	12	102	55	40	45	SCD601-1125-2-2-140HA03-HP358	30802210
11,30	12	102	55	40	45	SCD601-1130-2-2-140HA03-HP358	30802211
11,45	12	102	55	40	45	SCD601-1145-2-2-140HA03-HP358	30802214
11,50	12	102	55	40	45	SCD601-1150-2-2-140HA03-HP358	30802215
11,60	12	102	55	40	45	SCD601-1160-2-2-140HA03-HP358	30802216
11,70	12	102	55	40	45	SCD601-1170-2-2-140HA03-HP358	30802217
11,80	12	102	55	40	45	SCD601-1180-2-2-140HA03-HP358	30802218
11,90	12	102	55	40	45	SCD601-1190-2-2-140HA03-HP358	30802219
12,00	12	102	55	40	45	SCD601-1200-2-2-140HA03-HP358	30802220
12,15	14	107	60	43	45	SCD601-1215-2-2-140HA03-HP358	30802221
12,20	14	107	60	43	45	SCD601-1220-2-2-140HA03-HP358	31307544
12,25	14	107	60	43	45	SCD601-1225-2-2-140HA03-HP358	30802222
12,50	14	107	60	43	45	SCD601-1250-2-2-140HA03-HP358	30802223
12,55	14	107	60	43	45	SCD601-1255-2-2-140HA03-HP358	30802224
12,70	14	107	60	43	45	SCD601-1270-2-2-140HA03-HP358	30802225
12,80	14	107	60	43	45	SCD601-1280-2-2-140HA03-HP358	30802226
12,90	14	107	60	43	45	SCD601-1290-2-2-140HA03-HP358	30802227
13,00	14	107	60	43	45	SCD601-1300-2-2-140HA03-HP358	30802228
13,10	14	107	60	43	45	SCD601-1310-2-2-140HA03-HP358	30802229
13,30	14	107	60	43	45	SCD601-1330-2-2-140HA03-HP358	30802230
13,35	14	107	60	43	45	SCD601-1335-2-2-140HA03-HP358	30802231
13,50	14	107	60	43	45	SCD601-1350-2-2-140HA03-HP358	30802232
13,70	14	107	60	43	45	SCD601-1370-2-2-140HA03-HP358	30802233
13,80	14	107	60	43	45	SCD601-1380-2-2-140HA03-HP358	30802234
14,00	14	107	60	43	45	SCD601-1400-2-2-140HA03-HP358	30802235
14,20	16	115	65	45	48	SCD601-1420-2-2-140HA03-HP358	30802236
14,50	16	115	65	45	48	SCD601-1450-2-2-140HA03-HP358	30802237
14,80	16	115	65	45	48	SCD601-1480-2-2-140HA03-HP358	30802238
15,00	16	115	65	45	48	SCD601-1500-2-2-140HA03-HP358	30802239
15,10	16	115	65	45	48	SCD601-1510-2-2-140HA03-HP358	30802240
15,25	16	115	65	45	48	SCD601-1525-2-2-140HA03-HP358	30802241
15,30	16	115	65	45	48	SCD601-1530-2-2-140HA03-HP358	30802242
15,35	16	115	65	45	48	SCD601-1535-2-2-140HA03-HP358	30802243
15,50	16	115	65	45	48	SCD601-1550-2-2-140HA03-HP358	30802244
15,60	16	115	65	45	48	SCD601-1560-2-2-140HA03-HP358	30802245
15,80	16	115	65	45	48	SCD601-1580-2-2-140HA03-HP358	30802246
16,00	16	115	65	45	48	SCD601-1600-2-2-140HA03-HP358	30802247
16,05	18	123	73	51	48	SCD601-1605-2-2-140HA03-HP358	30802248
16,50	18	123	73	51	48	SCD601-1650-2-2-140HA03-HP358	30802249
16,60	18	123	73	51	48	SCD601-1660-2-2-140HA03-HP358	31307545
16,90	18	123	73	51	48	SCD601-1690-2-2-140HA03-HP358	30802251
17,00	18	123	73	51	48	SCD601-1700-2-2-140HA03-HP358	30802252
17,50	18	123	73	51	48	SCD601-1750-2-2-140HA03-HP358	30802253
17,60	18	123	73	51	48	SCD601-1760-2-2-140HA03-HP358	30802254
17,80	18	123	73	51	48	SCD601-1780-2-2-140HA03-HP358	30802255
18,00	18	123	73	51	48	SCD601-1800-2-2-140HA03-HP358	30802256
18,50	20	131	79	55	50	SCD601-1850-2-2-140HA03-HP358	30802257
18,90	20	131	79	55	50	SCD601-1890-2-2-140HA03-HP358	30802259
19,00	20	131	79	55	50	SCD601-1900-2-2-140HA03-HP358	30802260
19,35	20	131	79	55	50	SCD601-1935-2-2-140HA03-HP358	30802261
19,50	20	131	79	55	50	SCD601-1950-2-2-140HA03-HP358	30802262

MEGA-Drill-Steel-Plus | Punta elicoidale in metallo duro integrale SCD601 (3xD), adduzione interna del refrigerante

Dimensioni						Forma del codolo HA	
d ₁ m7	d ₂ h6	l ₁	l ₂	l ₃	l ₄	Specifiche	Codice
19,80	20	131	79	55	50	SCD601-1980-2-2-140HA03-HP358	30802264
20,00	20	131	79	55	50	SCD601-2000-2-2-140HA03-HP358	30802265
21,00	25	151	93	66	56	SCD601-2100-2-2-140HA03-HP358	30802267
21,50	25	151	93	66	56	SCD601-2150-2-2-140HA03-HP358	30802268
22,00	25	151	93	66	56	SCD601-2200-2-2-140HA03-HP358	30802269
23,50	25	151	93	66	56	SCD601-2350-2-2-140HA03-HP358	30802272

Caratteristiche configurabili

**Diametro:**

Diametro a libera scelta a passi da 0,01 mm

**Forma del codolo:**

Forma del codolo: HB | HE

Specifiche:

SCD601-[diametro]-3-3-140[forma del codolo]03-HP358

Esempio:

SCD601-0431-3-3-140HE03-HP358

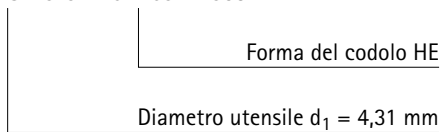

Dimensioni serie configurabile

d ₁ min.	d ₁ max.	d ₂ h6	l ₁	l ₂	l ₃	l ₄
3,00	3,70	6	62	20	14	36
3,71	4,70	6	66	24	17	36
4,71	6,00	6	66	28	20	36
6,01	7,00	8	79	34	24	36
7,01	8,00	8	79	41	29	36
8,01	10,00	10	89	47	35	40
10,01	12,00	12	102	55	40	45
12,01	14,00	14	107	60	43	45
14,01	16,00	16	115	65	45	48
16,01	18,00	18	123	73	51	48
18,01	20,00	20	131	79	55	50
20,01	25,00	25	151	93	66	56

Misure in mm.

* Specifica per la prefabbricazione di fori da maschiare per maschi a filettare.

Per i parametri di lavorazione consigliati, vedere la fine del capitolo.

Versioni speciali e altri rivestimenti disponibili su richiesta.

MEGA-Drill-Steel-Plus

Punta elicoidale in metallo duro integrale

SCD600 (5xD), adduzione esterna del refrigerante, prodotto successivo a MEGA-Drill-Steel (SCD10)

Versione:

Diametro punta:	3,00 – 20,00 mm
Tolleranza di foratura:	≥ IT 9
Materiale da taglio:	HP358
Numero di taglienti:	2
Numero margini di guida:	2
Angolo tra taglienti:	140°
Angolo dell'elica:	30°

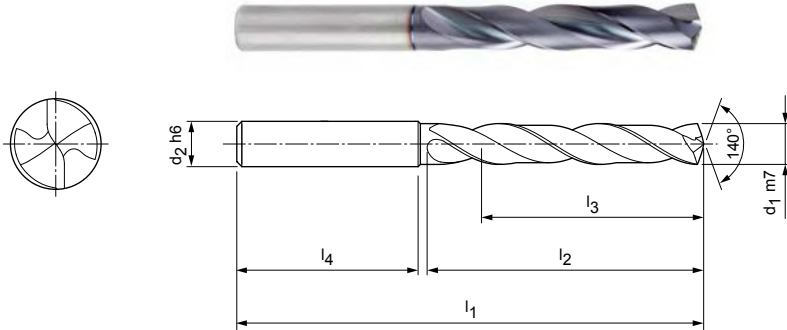

Serie selezionata per il magazzino con forma del codolo HA

Dimensioni						Forma del codolo HA	
d ₁ m7	d ₂ h6	l ₁	l ₂	l ₃	l ₄	Specifiche	Codice
3,00	6	66	28	23	36	SCD600-0300-2-2-140HA05-HP358	30801634
3,10	6	66	28	23	36	SCD600-0310-2-2-140HA05-HP358	30801635
3,15	6	66	28	23	36	SCD600-0315-2-2-140HA05-HP358	30801636
3,20	6	66	28	23	36	SCD600-0320-2-2-140HA05-HP358	30801637
3,25	6	66	28	23	36	SCD600-0325-2-2-140HA05-HP358	30801639
3,30	6	66	28	23	36	SCD600-0330-2-2-140HA05-HP358	30801640
3,40	6	66	28	23	36	SCD600-0340-2-2-140HA05-HP358	30801641
3,50	6	66	28	23	36	SCD600-0350-2-2-140HA05-HP358	30801642
3,60	6	66	28	23	36	SCD600-0360-2-2-140HA05-HP358	30801643
3,70	6	66	28	23	36	SCD600-0370-2-2-140HA05-HP358	30801644
3,80	6	74	36	29	36	SCD600-0380-2-2-140HA05-HP358	30801645
3,90	6	74	36	29	36	SCD600-0390-2-2-140HA05-HP358	30801647
4,00	6	74	36	29	36	SCD600-0400-2-2-140HA05-HP358	30801648
4,10	6	74	36	29	36	SCD600-0410-2-2-140HA05-HP358	30801649
4,20	6	74	36	29	36	SCD600-0420-2-2-140HA05-HP358	30801650
4,25	6	74	36	29	36	SCD600-0425-2-2-140HA05-HP358	30801651
4,30	6	74	36	29	36	SCD600-0430-2-2-140HA05-HP358	30801652
4,35	6	74	36	29	36	SCD600-0435-2-2-140HA05-HP358	30801653
4,40	6	74	36	29	36	SCD600-0440-2-2-140HA05-HP358	30801654
4,50	6	74	36	29	36	SCD600-0450-2-2-140HA05-HP358	30801656
4,60	6	74	36	29	36	SCD600-0460-2-2-140HA05-HP358	30801657
4,65	6	74	36	29	36	SCD600-0465-2-2-140HA05-HP358	30801658
4,70	6	74	36	29	36	SCD600-0470-2-2-140HA05-HP358	30801659
4,80	6	82	44	35	36	SCD600-0480-2-2-140HA05-HP358	30801660
4,90	6	82	44	35	36	SCD600-0490-2-2-140HA05-HP358	30801662
4,95	6	82	44	35	36	SCD600-0495-2-2-140HA05-HP358	30801663
5,00	6	82	44	35	36	SCD600-0500-2-2-140HA05-HP358	30801664
5,05	6	82	44	35	36	SCD600-0505-2-2-140HA05-HP358	30801665
5,10	6	82	44	35	36	SCD600-0510-2-2-140HA05-HP358	30801666
5,20	6	82	44	35	36	SCD600-0520-2-2-140HA05-HP358	30801667
5,30	6	82	44	35	36	SCD600-0530-2-2-140HA05-HP358	30801668
5,40	6	82	44	35	36	SCD600-0540-2-2-140HA05-HP358	30801669
5,50	6	82	44	35	36	SCD600-0550-2-2-140HA05-HP358	30801670
5,55	6	82	44	35	36	SCD600-0555-2-2-140HA05-HP358	30801671
5,60	6	82	44	35	36	SCD600-0560-2-2-140HA05-HP358	30801672

MEGA-Drill-Steel-Plus | Punta elicoidale in metallo duro integrale SCD600 (5xD), adduzione esterna del refrigerante

Dimensioni						Forma del codolo HA	
d ₁ m7	d ₂ h6	l ₁	l ₂	l ₃	l ₄	Specifiche	Codice
5,70	6	82	44	35	36	SCD600-0570-2-2-140HA05-HP358	30801673
5,75	6	82	44	35	36	SCD600-0575-2-2-140HA05-HP358	30801674
5,80	6	82	44	35	36	SCD600-0580-2-2-140HA05-HP358	30801675
5,90	6	82	44	35	36	SCD600-0590-2-2-140HA05-HP358	30801676
5,95	6	82	44	35	36	SCD600-0595-2-2-140HA05-HP358	30801677
6,00	6	82	44	35	36	SCD600-0600-2-2-140HA05-HP358	30801678
6,10	8	91	53	43	36	SCD600-0610-2-2-140HA05-HP358	30801679
6,20	8	91	53	43	36	SCD600-0620-2-2-140HA05-HP358	30801680
6,30	8	91	53	43	36	SCD600-0630-2-2-140HA05-HP358	30801681
6,40	8	91	53	43	36	SCD600-0640-2-2-140HA05-HP358	30801682
6,50	8	91	53	43	36	SCD600-0650-2-2-140HA05-HP358	30801683
6,60	8	91	53	43	36	SCD600-0660-2-2-140HA05-HP358	30801684
6,70	8	91	53	43	36	SCD600-0670-2-2-140HA05-HP358	30801685
6,80	8	91	53	43	36	SCD600-0680-2-2-140HA05-HP358	30801686
6,90	8	91	53	43	36	SCD600-0690-2-2-140HA05-HP358	30801687
7,00	8	91	53	43	36	SCD600-0700-2-2-140HA05-HP358	30801688
7,10	8	91	53	43	36	SCD600-0710-2-2-140HA05-HP358	30801689
7,20	8	91	53	43	36	SCD600-0720-2-2-140HA05-HP358	30801690
7,30	8	91	53	43	36	SCD600-0730-2-2-140HA05-HP358	30801691
7,40	8	91	53	43	36	SCD600-0740-2-2-140HA05-HP358	30801692
7,45	8	91	53	43	36	SCD600-0745-2-2-140HA05-HP358	30801693
7,50	8	91	53	43	36	SCD600-0750-2-2-140HA05-HP358	30801694
7,60	8	91	53	43	36	SCD600-0760-2-2-140HA05-HP358	30801695
7,80	8	91	53	43	36	SCD600-0780-2-2-140HA05-HP358	30801697
7,90	8	91	53	43	36	SCD600-0790-2-2-140HA05-HP358	30801698
8,00	8	91	53	43	36	SCD600-0800-2-2-140HA05-HP358	30801699
8,10	10	103	61	49	40	SCD600-0810-2-2-140HA05-HP358	30801700
8,20	10	103	61	49	40	SCD600-0820-2-2-140HA05-HP358	30801701
8,30	10	103	61	49	40	SCD600-0830-2-2-140HA05-HP358	30801702
8,40	10	103	61	49	40	SCD600-0840-2-2-140HA05-HP358	30801703
8,50	10	103	61	49	40	SCD600-0850-2-2-140HA05-HP358	30801704
8,60	10	103	61	49	40	SCD600-0860-2-2-140HA05-HP358	30801705
8,70	10	103	61	49	40	SCD600-0870-2-2-140HA05-HP358	30801706
8,80	10	103	61	49	40	SCD600-0880-2-2-140HA05-HP358	30801707
8,90	10	103	61	49	40	SCD600-0890-2-2-140HA05-HP358	30801708
9,00	10	103	61	49	40	SCD600-0900-2-2-140HA05-HP358	30801709
9,10	10	103	61	49	40	SCD600-0910-2-2-140HA05-HP358	30801710
9,20	10	103	61	49	40	SCD600-0920-2-2-140HA05-HP358	30801711
9,30	10	103	61	49	40	SCD600-0930-2-2-140HA05-HP358	30801712
9,50	10	103	61	49	40	SCD600-0950-2-2-140HA05-HP358	30801716
9,60	10	103	61	49	40	SCD600-0960-2-2-140HA05-HP358	30801717
9,70	10	103	61	49	40	SCD600-0970-2-2-140HA05-HP358	30801718
9,80	10	103	61	49	40	SCD600-0980-2-2-140HA05-HP358	30801719
9,90	10	103	61	49	40	SCD600-0990-2-2-140HA05-HP358	30801720
10,00	10	103	61	49	40	SCD600-1000-2-2-140HA05-HP358	30801721
10,10	12	118	71	56	45	SCD600-1010-2-2-140HA05-HP358	30801722
10,20	12	118	71	56	45	SCD600-1020-2-2-140HA05-HP358	30801723
10,30	12	118	71	56	45	SCD600-1030-2-2-140HA05-HP358	30801724
10,40	12	118	71	56	45	SCD600-1040-2-2-140HA05-HP358	30801725
10,50	12	118	71	56	45	SCD600-1050-2-2-140HA05-HP358	30801726
10,70	12	118	71	56	45	SCD600-1070-2-2-140HA05-HP358	30801729
10,75	12	118	71	56	45	SCD600-1075-2-2-140HA05-HP358	30801731
10,80	12	118	71	56	45	SCD600-1080-2-2-140HA05-HP358	30801732
11,00	12	118	71	56	45	SCD600-1100-2-2-140HA05-HP358	30801734
11,20	12	118	71	56	45	SCD600-1120-2-2-140HA05-HP358	30801736
11,25	12	118	71	56	45	SCD600-1125-2-2-140HA05-HP358	30801737
11,30	12	118	71	56	45	SCD600-1130-2-2-140HA05-HP358	30801738

MEGA-Drill-Steel-Plus | Punta elicoidale in metallo duro integrale SCD600 (5xD), adduzione esterna del refrigerante

Dimensioni						Forma del codolo HA	
d ₁ m7	d ₂ h6	l ₁	l ₂	l ₃	l ₄	Specifiche	Codice
11,35	12	118	71	56	45	SCD600-1135-2-2-140HA05-HP358	30801739
11,50	12	118	71	56	45	SCD600-1150-2-2-140HA05-HP358	30801742
11,80	12	118	71	56	45	SCD600-1180-2-2-140HA05-HP358	30801745
11,90	12	118	71	56	45	SCD600-1190-2-2-140HA05-HP358	30801746
12,00	12	118	71	56	45	SCD600-1200-2-2-140HA05-HP358	30801747
12,15	14	124	77	60	45	SCD600-1215-2-2-140HA05-HP358	30801748
12,25	14	124	77	60	45	SCD600-1225-2-2-140HA05-HP358	30801749
12,50	14	124	77	60	45	SCD600-1250-2-2-140HA05-HP358	30801750
12,70	14	124	77	60	45	SCD600-1270-2-2-140HA05-HP358	30801752
12,80	14	124	77	60	45	SCD600-1280-2-2-140HA05-HP358	30801753
12,90	14	124	77	60	45	SCD600-1290-2-2-140HA05-HP358	30801754
13,00	14	124	77	60	45	SCD600-1300-2-2-140HA05-HP358	30801755
13,10	14	124	77	60	45	SCD600-1310-2-2-140HA05-HP358	30801756
13,30	14	124	77	60	45	SCD600-1330-2-2-140HA05-HP358	30801757
13,35	14	124	77	60	45	SCD600-1335-2-2-140HA05-HP358	30801758
13,50	14	124	77	60	45	SCD600-1350-2-2-140HA05-HP358	30801759
13,80	14	124	77	60	45	SCD600-1380-2-2-140HA05-HP358	30801761
14,00	14	124	77	60	45	SCD600-1400-2-2-140HA05-HP358	30801762
14,20	16	133	83	63	48	SCD600-1420-2-2-140HA05-HP358	30801763
14,50	16	133	83	63	48	SCD600-1450-2-2-140HA05-HP358	30801764
14,80	16	133	83	63	48	SCD600-1480-2-2-140HA05-HP358	30801765
15,00	16	133	83	63	48	SCD600-1500-2-2-140HA05-HP358	30801766
15,10	16	133	83	63	48	SCD600-1510-2-2-140HA05-HP358	30801767
15,25	16	133	83	63	48	SCD600-1525-2-2-140HA05-HP358	30801768
15,30	16	133	83	63	48	SCD600-1530-2-2-140HA05-HP358	30801769
15,50	16	133	83	63	48	SCD600-1550-2-2-140HA05-HP358	30801771
15,80	16	133	83	63	48	SCD600-1580-2-2-140HA05-HP358	30801773
16,00	16	133	83	63	48	SCD600-1600-2-2-140HA05-HP358	30801774
16,50	18	143	93	71	48	SCD600-1650-2-2-140HA05-HP358	30801776
16,80	18	143	93	71	48	SCD600-1680-2-2-140HA05-HP358	30801777
17,00	18	143	93	71	48	SCD600-1700-2-2-140HA05-HP358	30801779
17,50	18	143	93	71	48	SCD600-1750-2-2-140HA05-HP358	30801780
17,60	18	143	93	71	48	SCD600-1760-2-2-140HA05-HP358	30801781
18,00	18	143	93	71	48	SCD600-1800-2-2-140HA05-HP358	30801783
18,50	20	153	101	77	50	SCD600-1850-2-2-140HA05-HP358	30801784
18,80	20	153	101	77	50	SCD600-1880-2-2-140HA05-HP358	30801785
18,90	20	153	101	77	50	SCD600-1890-2-2-140HA05-HP358	30801786
19,00	20	153	101	77	50	SCD600-1900-2-2-140HA05-HP358	30801787
19,50	20	153	101	77	50	SCD600-1950-2-2-140HA05-HP358	30801789
19,80	20	153	101	77	50	SCD600-1980-2-2-140HA05-HP358	30801791
20,00	20	153	101	77	50	SCD600-2000-2-2-140HA05-HP358	30801792

Prosegue alla pagina seguente.

MEGA-Drill-Steel-Plus | Punta elicoidale in metallo duro integrale SCD600 (5xD), adduzione esterna del refrigerante

Caratteristiche configurabili

**Diametro:**

Diametro a libera scelta a passi da 0,01 mm

**Forma del codolo:**

Forma del codolo: HB | HE

Specifiche:

SCD600-[diametro]-3-3-140[forma del codolo]05-HP358

Dimensioni serie configurabile

d ₁ min.	d ₁ max.	d ₂ h6	l ₁	l ₂	l ₃	l ₄
3,00	3,70	6	66	28	23	36
3,71	4,70	6	74	36	29	36
4,71	6,00	6	82	44	35	36
6,01	8,00	8	91	53	43	36
8,01	10,00	10	103	61	49	40
10,01	12,00	12	118	71	56	45
12,01	14,00	14	124	77	60	45
14,01	16,00	16	133	83	63	48
16,01	18,00	18	143	93	71	48
18,01	20,00	20	153	101	77	50

Esempio:

SCD600-0431-3-3-140HE05-HP358

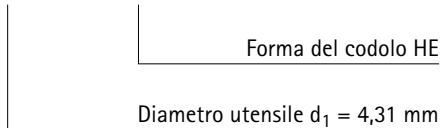

MEGA-Drill-Steel-Plus

Punta elicoidale in metallo duro integrale

SCD601 (5xD), adduzione interna del refrigerante, prodotto successivo a MEGA-Drill-Steel (SCD10)

Versione:

Diametro punta:	3,00 – 25,00 mm
Tolleranza di foratura:	≥ IT 9
Materiale da taglio:	HP358
Numero di taglienti:	2
Numero margini di guida:	2
Angolo tra taglienti:	140°
Angolo dell'elica:	30°

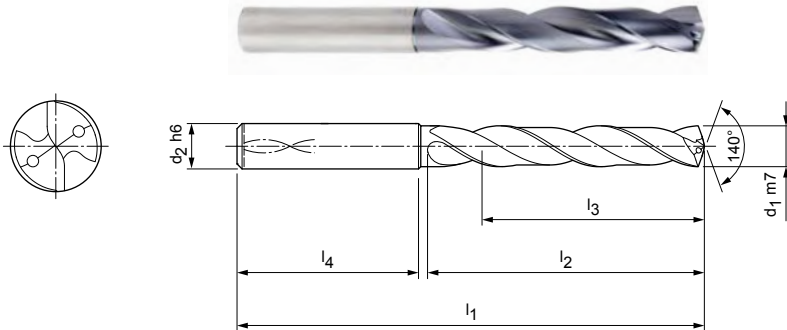

Serie selezionata per il magazzino con forma del codolo HA

Dimensioni						Forma del codolo HA	
d ₁ m7	d ₂ h6	l ₁	l ₂	l ₃	l ₄	Specifiche	Codice
3,00	6	66	28	23	36	SCD601-0300-2-2-140HA05-HP358	30802611
3,10	6	66	28	23	36	SCD601-0310-2-2-140HA05-HP358	30802612
3,15	6	66	28	23	36	SCD601-0315-2-2-140HA05-HP358	30802613
3,20	6	66	28	23	36	SCD601-0320-2-2-140HA05-HP358	30802614
3,25	6	66	28	23	36	SCD601-0325-2-2-140HA05-HP358	30802616
3,30	6	66	28	23	36	SCD601-0330-2-2-140HA05-HP358	30802617
3,40	6	66	28	23	36	SCD601-0340-2-2-140HA05-HP358	30802618
3,50	6	66	28	23	36	SCD601-0350-2-2-140HA05-HP358	30802619
3,60	6	66	28	23	36	SCD601-0360-2-2-140HA05-HP358	30802620
3,65	6	66	28	23	36	SCD601-0365-2-2-140HA05-HP358	31307546
3,70*	6	66	28	23	36	SCD601-0370-2-2-140HA05-HP358	30802621
3,80	6	74	36	29	36	SCD601-0380-2-2-140HA05-HP358	30802622
3,85	6	74	36	29	36	SCD601-0385-2-2-140HA05-HP358	30802623
3,90	6	74	36	29	36	SCD601-0390-2-2-140HA05-HP358	30802624
4,00	6	74	36	29	36	SCD601-0400-2-2-140HA05-HP358	30802625
4,10	6	74	36	29	36	SCD601-0410-2-2-140HA05-HP358	30802626
4,20	6	74	36	29	36	SCD601-0420-2-2-140HA05-HP3583	30802627
4,25	6	74	36	29	36	SCD601-0425-2-2-140HA05-HP358	30802628
4,30	6	74	36	29	36	SCD601-0430-2-2-140HA05-HP358	30802629
4,35	6	74	36	29	36	SCD601-0435-2-2-140HA05-HP358	30802630
4,40	6	74	36	29	36	SCD601-0440-2-2-140HA05-HP358	30802631
4,45	6	74	36	29	36	SCD601-0445-2-2-140HA05-HP358	30802632
4,50	6	74	36	29	36	SCD601-0450-2-2-140HA05-HP358	30802633
4,60	6	74	36	29	36	SCD601-0460-2-2-140HA05-HP358	30802634
4,65*	6	74	36	29	36	SCD601-0465-2-2-140HA05-HP358	30802635
4,70	6	74	36	29	36	SCD601-0470-2-2-140HA05-HP358	30802636
4,80	6	82	44	35	36	SCD601-0480-2-2-140HA05-HP358	30802637
4,90	6	82	44	35	36	SCD601-0490-2-2-140HA05-HP358	30802638
4,95	6	82	44	35	36	SCD601-0495-2-2-140HA05-HP358	30802639
5,00	6	82	44	35	36	SCD601-0500-2-2-140HA05-HP358	30802640
5,05	6	82	44	35	36	SCD601-0505-2-2-140HA05-HP358	30802641
5,10	6	82	44	35	36	SCD601-0510-2-2-140HA05-HP358	30802642
5,20	6	82	44	35	36	SCD601-0520-2-2-140HA05-HP358	30802643
5,30	6	82	44	35	36	SCD601-0530-2-2-140HA05-HP358	30802644
5,40	6	82	44	35	36	SCD601-0540-2-2-140HA05-HP358	30802645

MEGA-Drill-Steel-Plus | Punta elicoidale in metallo duro integrale SCD601 (5xD), adduzione interna del refrigerante

Dimensioni						Forma del codolo HA	
d ₁ m7	d ₂ h6	l ₁	l ₂	l ₃	l ₄	Specifiche	Codice
5,50	6	82	44	35	36	SCD601-0550-2-2-140HA05-HP358	30802646
5,55*	6	82	44	35	36	SCD601-0555-2-2-140HA05-HP358	30802647
5,60	6	82	44	35	36	SCD601-0560-2-2-140HA05-HP358	30802648
5,70	6	82	44	35	36	SCD601-0570-2-2-140HA05-HP358	30802649
5,75	6	82	44	35	36	SCD601-0575-2-2-140HA05-HP358	30802650
5,80	6	82	44	35	36	SCD601-0580-2-2-140HA05-HP358	30802651
5,90	6	82	44	35	36	SCD601-0590-2-2-140HA05-HP358	30802652
5,95	6	82	44	35	36	SCD601-0595-2-2-140HA05-HP358	30802653
6,00	6	82	44	35	36	SCD601-0600-2-2-140HA05-HP358	30802654
6,10	8	91	53	43	36	SCD601-0610-2-2-140HA05-HP358	30802655
6,20	8	91	53	43	36	SCD601-0620-2-2-140HA05-HP358	30802656
6,30	8	91	53	43	36	SCD601-0630-2-2-140HA05-HP358	30802657
6,40	8	91	53	43	36	SCD601-0640-2-2-140HA05-HP358	30802658
6,50	8	91	53	43	36	SCD601-0650-2-2-140HA05-HP358	30802659
6,60	8	91	53	43	36	SCD601-0660-2-2-140HA05-HP358	30802660
6,70	8	91	53	43	36	SCD601-0670-2-2-140HA05-HP358	30802661
6,80	8	91	53	43	36	SCD601-0680-2-2-140HA05-HP358	30802662
6,90	8	91	53	43	36	SCD601-0690-2-2-140HA05-HP358	30802663
7,00	8	91	53	43	36	SCD601-0700-2-2-140HA05-HP358	30802664
7,10	8	91	53	43	36	SCD601-0710-2-2-140HA05-HP358	30802665
7,20	8	91	53	43	36	SCD601-0720-2-2-140HA05-HP358	30802666
7,30	8	91	53	43	36	SCD601-0730-2-2-140HA05-HP358	30802667
7,40	8	91	53	43	36	SCD601-0740-2-2-140HA05-HP358	30802668
7,45*	8	91	53	43	36	SCD601-0745-2-2-140HA05-HP358	30802669
7,50	8	91	53	43	36	SCD601-0750-2-2-140HA05-HP358	30802670
7,60	8	91	53	43	36	SCD601-0760-2-2-140HA05-HP358	30802671
7,70	8	91	53	43	36	SCD601-0770-2-2-140HA05-HP358	30802672
7,80	8	91	53	43	36	SCD601-0780-2-2-140HA05-HP358	30802673
7,90	8	91	53	43	36	SCD601-0790-2-2-140HA05-HP358	30802674
8,00	8	91	53	43	36	SCD601-0800-2-2-140HA05-HP358	30802675
8,10	10	103	61	49	40	SCD601-0810-2-2-140HA05-HP358	30802676
8,20	10	103	61	49	40	SCD601-0820-2-2-140HA05-HP358	30802677
8,30	10	103	61	49	40	SCD601-0830-2-2-140HA05-HP358	30802678
8,40	10	103	61	49	40	SCD601-0840-2-2-140HA05-HP358	30802679
8,50	10	103	61	49	40	SCD601-0850-2-2-140HA05-HP358	30802680
8,60	10	103	61	49	40	SCD601-0860-2-2-140HA05-HP358	30802681
8,70	10	103	61	49	40	SCD601-0870-2-2-140HA05-HP358	30802682
8,80	10	103	61	49	40	SCD601-0880-2-2-140HA05-HP358	30802683
8,90	10	103	61	49	40	SCD601-0890-2-2-140HA05-HP358	30802684
9,00	10	103	61	49	40	SCD601-0900-2-2-140HA05-HP358	30802685
9,10	10	103	61	49	40	SCD601-0910-2-2-140HA05-HP358	30802686
9,20	10	103	61	49	40	SCD601-0920-2-2-140HA05-HP358	30802687
9,30*	10	103	61	49	40	SCD601-0930-2-2-140HA05-HP358	30802688
9,35	10	103	61	49	40	SCD601-0935-2-2-140HA05-HP358	30802689
9,40	10	103	61	49	40	SCD601-0940-2-2-140HA05-HP358	30802690
9,45	10	103	61	49	40	SCD601-0945-2-2-140HA05-HP358	30802691
9,50	10	103	61	49	40	SCD601-0950-2-2-140HA05-HP358	30802692
9,60	10	103	61	49	40	SCD601-0960-2-2-140HA05-HP358	30802693
9,70	10	103	61	49	40	SCD601-0970-2-2-140HA05-HP358	30802694
9,80	10	103	61	49	40	SCD601-0980-2-2-140HA05-HP358	30802695
9,90	10	103	61	49	40	SCD601-0990-2-2-140HA05-HP358	30802696
10,00	10	103	61	49	40	SCD601-1000-2-2-140HA05-HP358	30802697
10,10	12	118	71	56	45	SCD601-1010-2-2-140HA05-HP358	30802698
10,20	12	118	71	56	45	SCD601-1020-2-2-140HA05-HP358	30802699
10,30	12	118	71	56	45	SCD601-1030-2-2-140HA05-HP358	30802700
10,40	12	118	71	56	45	SCD601-1040-2-2-140HA05-HP358	30802701
10,50	12	118	71	56	45	SCD601-1050-2-2-140HA05-HP358	30802702

MEGA-Drill-Steel-Plus | Punta elicoidale in metallo duro integrale SCD601 (5xD), adduzione interna del refrigerante

Dimensioni						Forma del codolo HA	
d ₁ m7	d ₂ h6	l ₁	l ₂	l ₃	l ₄	Specifiche	Codice
10,55	12	118	71	56	45	SCD601-1055-2-2-140HA05-HP358	30802703
10,60	12	118	71	56	45	SCD601-1060-2-2-140HA05-HP358	30802704
10,70	12	118	71	56	45	SCD601-1070-2-2-140HA05-HP358	30802705
10,80	12	118	71	56	45	SCD601-1080-2-2-140HA05-HP358	30802707
10,90	12	118	71	56	45	SCD601-1090-2-2-140HA05-HP358	30802708
11,00	12	118	71	56	45	SCD601-1100-2-2-140HA05-HP358	30802709
11,10	12	118	71	56	45	SCD601-1110-2-2-140HA05-HP358	30802710
11,20*	12	118	71	56	45	SCD601-1120-2-2-140HA05-HP358	30802711
11,25	12	118	71	56	45	SCD601-1125-2-2-140HA05-HP358	30802712
11,30	12	118	71	56	45	SCD601-1130-2-2-140HA05-HP358	30802713
11,40	12	118	71	56	45	SCD601-1140-2-2-140HA05-HP358	30802715
11,50	12	118	71	56	45	SCD601-1150-2-2-140HA05-HP358	30802717
11,60	12	118	71	56	45	SCD601-1160-2-2-140HA05-HP358	30802718
11,70	12	118	71	56	45	SCD601-1170-2-2-140HA05-HP358	30802719
11,80	12	118	71	56	45	SCD601-1180-2-2-140HA05-HP358	30802720
11,90	12	118	71	56	45	SCD601-1190-2-2-140HA05-HP358	30802721
12,00	12	118	71	56	45	SCD601-1200-2-2-140HA05-HP358	30802722
12,15	14	124	77	60	45	SCD601-1215-2-2-140HA05-HP358	30802723
12,25	14	124	77	60	45	SCD601-1225-2-2-140HA05-HP358	30802724
12,30	14	124	77	60	45	SCD601-1230-2-2-140HA05-HP358	31201193
12,50	14	124	77	60	45	SCD601-1250-2-2-140HA05-HP358	30802725
12,55	14	124	77	60	45	SCD601-1255-2-2-140HA05-HP358	30802726
12,70	14	124	77	60	45	SCD601-1270-2-2-140HA05-HP358	30802727
12,80	14	124	77	60	45	SCD601-1280-2-2-140HA05-HP358	30802728
12,90	14	124	77	60	45	SCD601-1290-2-2-140HA05-HP358	30802729
13,00	14	124	77	60	45	SCD601-1300-2-2-140HA05-HP358	30802730
13,10	14	124	77	60	45	SCD601-1310-2-2-140HA05-HP358	30802731
13,30	14	124	77	60	45	SCD601-1330-2-2-140HA05-HP358	30802732
13,35	14	124	77	60	45	SCD601-1335-2-2-140HA05-HP358	30802733
13,50	14	124	77	60	45	SCD601-1350-2-2-140HA05-HP358	30802734
13,70	14	124	77	60	45	SCD601-1370-2-2-140HA05-HP358	30802735
13,80	14	124	77	60	45	SCD601-1380-2-2-140HA05-HP358	30802736
14,00	14	124	77	60	45	SCD601-1400-2-2-140HA05-HP358	30802737
14,20	16	133	83	63	48	SCD601-1420-2-2-140HA05-HP358	30802738
14,50	16	133	83	63	48	SCD601-1450-2-2-140HA05-HP358	30802739
14,80	16	133	83	63	48	SCD601-1480-2-2-140HA05-HP358	30802740
15,00	16	133	83	63	48	SCD601-1500-2-2-140HA05-HP358	30802741
15,10	16	133	83	63	48	SCD601-1510-2-2-140HA05-HP358	30802742
15,25	16	133	83	63	48	SCD601-1525-2-2-140HA05-HP358	30802743
15,30	16	133	83	63	48	SCD601-1530-2-2-140HA05-HP358	30802744
15,35	16	133	83	63	48	SCD601-1535-2-2-140HA05-HP358	30802745
15,50	16	133	83	63	48	SCD601-1550-2-2-140HA05-HP358	30802746
15,60	16	133	83	63	48	SCD601-1560-2-2-140HA05-HP358	30802747
15,80	16	133	83	63	48	SCD601-1580-2-2-140HA05-HP358	30802748
16,00	16	133	83	63	48	SCD601-1600-2-2-140HA05-HP358	30802749
16,05	18	143	93	71	48	SCD601-1605-2-2-140HA05-HP358	30802750
16,50	18	143	93	71	48	SCD601-1650-2-2-140HA05-HP358	30802751
16,80	18	143	93	71	48	SCD601-1680-2-2-140HA05-HP358	30802752
16,90	18	143	93	71	48	SCD601-1690-2-2-140HA05-HP358	30802753
17,00	18	143	93	71	48	SCD601-1700-2-2-140HA05-HP358	30802754

Prosegue alla pagina seguente.

MEGA-Drill-Steel-Plus | Punta elicoidale in metallo duro integrale SCD601 (5xD), adduzione interna del refrigerante

Caratteristiche configurabili

**Diametro:**

Diametro a libera scelta a passi da 0,01 mm

**Forma del codolo:**

Forma del codolo: HB | HE

Specifiche:

SCD601-[diametro]-3-3-140[forma del codolo]05-HP358

Esempio:

SCD601-0431-3-3-140HE05-HP358

Forma del codolo HE

Diametro utensile $d_1 = 4,31$ mm

Dimensioni serie configurabile

d_1 min.	d_1 max.	d_2 h6	l_1	l_2	l_3	l_4
3,00	3,70	6	66	28	23	36
3,71	4,70	6	74	36	29	36
4,71	6,00	6	82	44	35	36
6,01	8,00	8	91	53	43	36
8,01	10,00	10	103	61	49	40
10,01	12,00	12	118	71	56	45
12,01	14,00	14	124	77	60	45
14,01	16,00	16	133	83	63	48
16,01	18,00	18	143	93	71	48
18,01	20,00	20	153	101	77	50
20,01	22,00	25	200	135	110	56
22,01	25,00	25	200	140	120	56

Misure in mm.

* Specifica per la prefabbricazione di fori da maschiare per maschi a filettare.

Per i parametri di lavorazione consigliati, vedere la fine del capitolo.

Versioni speciali e altri rivestimenti disponibili su richiesta.

MEGA-Drill-Steel-Plus

Punta elicoidale in metallo duro integrale

SCD601 (8xD), adduzione interna del refrigerante, prodotto successivo a MEGA-Drill-Steel (SCD10)

Versione:

Diametro punta:	3,00 – 20,00 mm
Tolleranza di foratura:	≥ IT 9
Materiale da taglio:	HP358
Numero di taglienti:	2
Numero margini di guida:	2
Angolo tra taglienti:	135°
Angolo dell'elica:	30°

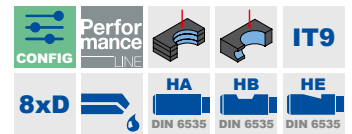
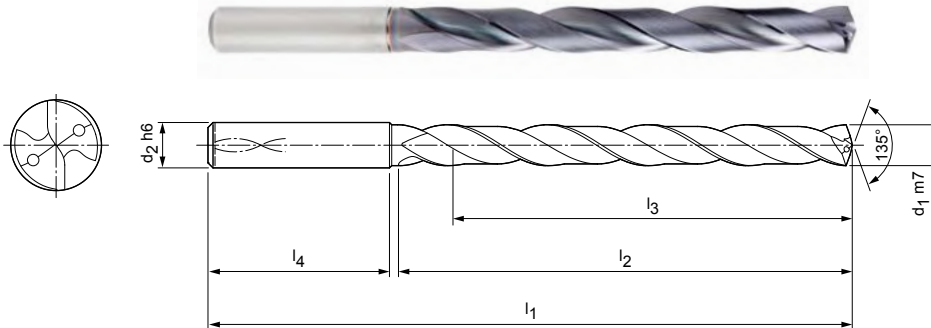

Serie selezionata per il magazzino con forma del codolo HA

Dimensioni						Forma del codolo HA	
d ₁ m7	d ₂ h6	l ₁	l ₂	l ₃	l ₄	Specifiche	Codice
3,00	6	72	34	29	36	SCD601-0300-2-2-135HA08-HP358	30803112
3,10	6	72	34	29	36	SCD601-0310-2-2-135HA08-HP358	30803113
3,20	6	72	34	29	36	SCD601-0320-2-2-135HA08-HP358	30803114
3,30	6	72	34	29	36	SCD601-0330-2-2-135HA08-HP358	30803115
3,40	6	72	34	29	36	SCD601-0340-2-2-135HA08-HP358	30803116
3,50	6	72	34	29	36	SCD601-0350-2-2-135HA08-HP358	30803117
3,60	6	72	34	29	36	SCD601-0360-2-2-135HA08-HP358	30803118
3,70	6	72	34	29	36	SCD601-0370-2-2-135HA08-HP358	30803119
3,80	6	81	43	36	36	SCD601-0380-2-2-135HA08-HP358	30803120
3,90	6	81	43	36	36	SCD601-0390-2-2-135HA08-HP358	30803121
4,00	6	81	43	36	36	SCD601-0400-2-2-135HA08-HP358	30803122
4,10	6	81	43	36	36	SCD601-0410-2-2-135HA08-HP358	30803123
4,20	6	81	43	36	36	SCD601-0420-2-2-135HA08-HP358	30803124
4,30	6	81	43	36	36	SCD601-0430-2-2-135HA08-HP358	30803125
4,40	6	81	43	36	36	SCD601-0440-2-2-135HA08-HP358	30803126
4,50	6	81	43	36	36	SCD601-0450-2-2-135HA08-HP358	30803127
4,60	6	81	43	36	36	SCD601-0460-2-2-135HA08-HP358	30803128
4,70	6	81	43	36	36	SCD601-0470-2-2-135HA08-HP358	30803129
4,80	6	95	57	48	36	SCD601-0480-2-2-135HA08-HP358	30803130
4,90	6	95	57	48	36	SCD601-0490-2-2-135HA08-HP358	30803131
5,00	6	95	57	48	36	SCD601-0500-2-2-135HA08-HP358	30803132
5,10	6	95	57	48	36	SCD601-0510-2-2-135HA08-HP358	30803133
5,20	6	95	57	48	36	SCD601-0520-2-2-135HA08-HP358	30803134
5,30	6	95	57	48	36	SCD601-0530-2-2-135HA08-HP358	30803135
5,40	6	95	57	48	36	SCD601-0540-2-2-135HA08-HP358	30803136
5,50	6	95	57	48	36	SCD601-0550-2-2-135HA08-HP358	30803137
5,60	6	95	57	48	36	SCD601-0560-2-2-135HA08-HP358	30803138
5,70	6	95	57	48	36	SCD601-0570-2-2-135HA08-HP358	30803139
5,80	6	95	57	48	36	SCD601-0580-2-2-135HA08-HP358	30803140
5,90	6	95	57	48	36	SCD601-0590-2-2-135HA08-HP358	30803141
6,00	6	95	57	48	36	SCD601-0600-2-2-135HA08-HP358	30803142
6,10	8	114	76	64	36	SCD601-0610-2-2-135HA08-HP358	30803143
6,20	8	114	76	64	36	SCD601-0620-2-2-135HA08-HP358	30803144
6,30	8	114	76	64	36	SCD601-0630-2-2-135HA08-HP358	30803145
6,40	8	114	76	64	36	SCD601-0640-2-2-135HA08-HP358	30803146

ECU-Drill-Steel | Punta elicoidale in metallo duro integrale SCD601 (8xD), adduzione interna del refrigerante

Dimensioni						Forma del codolo HA	
d ₁ m7	d ₂ h6	l ₁	l ₂	l ₃	l ₄	Specifiche	Codice
6,50	8	114	76	64	36	SCD601-0650-2-2-135HA08-HP358	30803147
6,60	8	114	76	64	36	SCD601-0660-2-2-135HA08-HP358	30803148
6,70	8	114	76	64	36	SCD601-0670-2-2-135HA08-HP358	30803149
6,80	8	114	76	64	36	SCD601-0680-2-2-135HA08-HP358	30803150
6,90	8	114	76	64	36	SCD601-0690-2-2-135HA08-HP358	30803151
7,00	8	114	76	64	36	SCD601-0700-2-2-135HA08-HP358	30803152
7,10	8	114	76	64	36	SCD601-0710-2-2-135HA08-HP358	30803153
7,20	8	114	76	64	36	SCD601-0720-2-2-135HA08-HP358	30803154
7,30	8	114	76	64	36	SCD601-0730-2-2-135HA08-HP358	30803155
7,40	8	114	76	64	36	SCD601-0740-2-2-135HA08-HP358	30803156
7,50	8	114	76	64	36	SCD601-0750-2-2-135HA08-HP358	30803157
7,60	8	114	76	64	36	SCD601-0760-2-2-135HA08-HP358	30803158
7,70	8	114	76	64	36	SCD601-0770-2-2-135HA08-HP358	30803159
7,80	8	114	76	64	36	SCD601-0780-2-2-135HA08-HP358	30803160
7,90	8	114	76	64	36	SCD601-0790-2-2-135HA08-HP358	30803161
8,00	8	114	76	64	36	SCD601-0800-2-2-135HA08-HP358	30803162
8,10	10	142	95	80	40	SCD601-0810-2-2-135HA08-HP358	30803163
8,20	10	142	95	80	40	SCD601-0820-2-2-135HA08-HP358	30803164
8,40	10	142	95	80	40	SCD601-0840-2-2-135HA08-HP358	30803166
8,50	10	142	95	80	40	SCD601-0850-2-2-135HA08-HP358	30803167
8,60	10	142	95	80	40	SCD601-0860-2-2-135HA08-HP358	30803168
8,70	10	142	95	80	40	SCD601-0870-2-2-135HA08-HP358	30803169
8,80	10	142	95	80	40	SCD601-0880-2-2-135HA08-HP358	30803170
8,90	10	142	95	80	40	SCD601-0890-2-2-135HA08-HP358	30803171
9,00	10	142	95	80	40	SCD601-0900-2-2-135HA08-HP358	30803172
9,10	10	142	95	80	40	SCD601-0910-2-2-135HA08-HP358	30803173
9,20	10	142	95	80	40	SCD601-0920-2-2-135HA08-HP358	30803174
9,30	10	142	95	80	40	SCD601-0930-2-2-135HA08-HP358	30803175
9,40	10	142	95	80	40	SCD601-0940-2-2-135HA08-HP358	30803176
9,50	10	142	95	80	40	SCD601-0950-2-2-135HA08-HP358	30803177
9,60	10	142	95	80	40	SCD601-0960-2-2-135HA08-HP358	30803178
9,80	10	142	95	80	40	SCD601-0980-2-2-135HA08-HP358	30803180
9,90	10	142	95	80	40	SCD601-0990-2-2-135HA08-HP358	30803181
10,00	10	142	95	80	40	SCD601-1000-2-2-135HA08-HP358	30803182
10,10	12	162	114	96	45	SCD601-1010-2-2-135HA08-HP358	30803183
10,20	12	162	114	96	45	SCD601-1020-2-2-135HA08-HP358	30803184
10,30	12	162	114	95	45	SCD601-1030-2-2-135HA08-HP358	30803185
10,40	12	162	114	96	45	SCD601-1040-2-2-135HA08-HP358	30803186
10,50	12	162	114	96	45	SCD601-1050-2-2-135HA08-HP358	30803187
10,70	12	162	114	96	45	SCD601-1070-2-2-135HA08-HP358	30803189
10,80	12	162	114	96	45	SCD601-1080-2-2-135HA08-HP358	30803190
11,00	12	162	114	96	45	SCD601-1100-2-2-135HA08-HP358	30803192
11,10	12	162	114	96	45	SCD601-1110-2-2-135HA08-HP358	30803193
11,20	12	162	114	96	45	SCD601-1120-2-2-135HA08-HP358	30803194
11,30	12	162	114	96	45	SCD601-1130-2-2-135HA08-HP358	30803195
11,40	12	162	114	96	45	SCD601-1140-2-2-135HA08-HP358	30803196
11,50	12	162	114	96	45	SCD601-1150-2-2-135HA08-HP358	30803197
11,80	12	162	114	96	45	SCD601-1180-2-2-135HA08-HP358	30803200
12,00	12	162	114	96	45	SCD601-1200-2-2-135HA08-HP358	30803202
12,50	14	178	133	112	45	SCD601-1250-2-2-135HA08-HP358	30803203
12,80	14	178	133	112	45	SCD601-1280-2-2-135HA08-HP358	30803204
13,00	14	178	133	112	45	SCD601-1300-2-2-135HA08-HP358	30803205
13,50	14	178	133	112	45	SCD601-1350-2-2-135HA08-HP358	30803206
13,80	14	178	133	112	45	SCD601-1380-2-2-135HA08-HP358	30803207
14,00	14	178	133	112	45	SCD601-1400-2-2-135HA08-HP358	30803208
14,50	16	203	152	128	48	SCD601-1450-2-2-135HA08-HP358	30803209
14,80	16	203	152	128	48	SCD601-1480-2-2-135HA08-HP358	30803210

ECU-Drill-Steel | Punta elicoidale in metallo duro integrale SCD601 (8xD), adduzione interna del refrigerante

Dimensioni						Forma del codolo HA	
d ₁ m7	d ₂ h6	l ₁	l ₂	l ₃	l ₄	Specifiche	Codice
15,00	16	203	152	128	48	SCD601-1500-2-2-135HA08-HP358	30803211
15,50	16	203	152	128	48	SCD601-1550-2-2-135HA08-HP358	30803212
15,80	16	203	152	128	48	SCD601-1580-2-2-135HA08-HP358	30803213
16,00	16	203	152	128	48	SCD601-1600-2-2-135HA08-HP358	30803214
17,00	18	222	171	144	48	SCD601-1700-2-2-135HA08-HP358	30803217
17,50	18	222	171	144	48	SCD601-1750-2-2-135HA08-HP358	30803218
17,80	18	222	171	144	48	SCD601-1780-2-2-135HA08-HP358	30803219
18,00	18	222	171	144	48	SCD601-1800-2-2-135HA08-HP358	30803220
18,50	20	243	190	160	50	SCD601-1850-2-2-135HA08-HP358	30803221
18,80	20	243	190	160	50	SCD601-1880-2-2-135HA08-HP358	30803222
19,50	20	243	190	160	50	SCD601-1950-2-2-135HA08-HP358	30803224
19,80	20	243	190	160	50	SCD601-1980-2-2-135HA08-HP358	30803225
20,00	20	243	190	160	50	SCD601-2000-2-2-135HA08-HP358	30803226

Caratteristiche configurabili

**Diametro:**

Diametro a libera scelta a passi da 0,01 mm

**Forma del codolo:**

Forma del codolo: HB | HE

Specifiche:

SCD601-[diametro]-2-2-135[forma del codolo]08-HP358

Dimensioni serie configurabile

d ₁ min.	d ₁ max.	d ₂ h6	l ₁	l ₂	l ₃	l ₄
3,00	3,70	6	72	34	29	36
3,71	4,70	6	81	43	36	36
4,71	6,00	6	95	57	48	36
6,01	8,00	8	114	76	64	36
8,01	10,00	10	142	95	80	40
10,01	12,00	12	162	114	96	45
12,01	14,00	14	178	133	112	45
14,01	16,00	16	203	152	128	48
16,01	18,00	18	222	171	144	48
18,01	20,00	20	243	190	160	50

Esempio:

SCD601-0431-2-2-135HE08-HP358

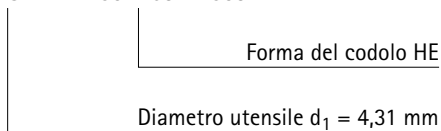

Misure in mm.

Per i parametri di lavorazione consigliati, vedere la fine del capitolo.

Versioni speciali e altri rivestimenti disponibili su richiesta.

MEGA-Quadro-Drill-Plus

Punta elicoidale in metallo duro integrale

SCD610 (5xD), adduzione esterna del refrigerante, prodotto successivo a MEGA-Quadro-Drill (SCD16)

Versione:

Diametro punta: 3,00 – 20,00 mm
 Tolleranza di foratura: \geq IT 8
 Materiale da taglio: HP358
 Numero di taglianti: 2
 Numero margini di guida: 4
 Angolo tra taglianti: 140°
 Angolo dell'elica: 30°

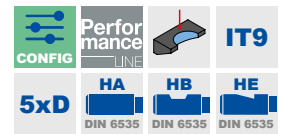
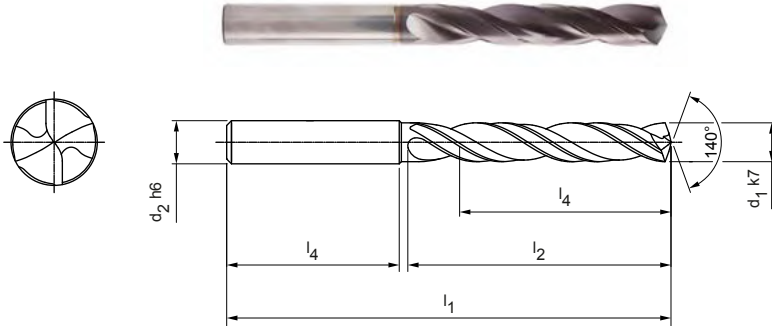

Serie selezionata per il magazzino con forma del codolo HA

Dimensioni						Forma del codolo HA	
d ₁ k7	d ₂ h6	l ₁	l ₂	l ₃	l ₄	Specifiche	Codice
3,00	6	66	28	23	36	SCD610-0300-2-4-140HA05-HP358	31052631
3,10	6	66	28	23	36	SCD610-0310-2-4-140HA05-HP358	31052632
3,20	6	66	28	23	36	SCD610-0320-2-4-140HA05-HP358	31052633
3,30	6	66	28	23	36	SCD610-0330-2-4-140HA05-HP358	31052634
3,40	6	66	28	23	36	SCD610-0340-2-4-140HA05-HP358	31052635
3,50	6	66	28	23	36	SCD610-0350-2-4-140HA05-HP358	31052636
3,70	6	66	28	23	36	SCD610-0370-2-4-140HA05-HP358	31052638
4,00	6	74	36	29	36	SCD610-0400-2-4-140HA05-HP358	31052641
4,20	6	74	36	29	36	SCD610-0420-2-4-140HA05-HP358	31052643
4,30	6	74	36	29	36	SCD610-0430-2-4-140HA05-HP358	31052644
4,50	6	74	36	29	36	SCD610-0450-2-4-140HA05-HP358	31052646
4,80	6	82	44	35	36	SCD610-0480-2-4-140HA05-HP358	31052649
5,00	6	82	44	35	36	SCD610-0500-2-4-140HA05-HP358	31052651
5,10	6	82	44	35	36	SCD610-0510-2-4-140HA05-HP358	31052652
5,20	6	82	44	35	36	SCD610-0520-2-4-140HA05-HP358	31052653
5,50	6	82	44	35	36	SCD610-0550-2-4-140HA05-HP358	31052656
5,60	6	82	44	35	36	SCD610-0560-2-4-140HA05-HP358	31052657
5,80	6	82	44	35	36	SCD610-0580-2-4-140HA05-HP358	31052659
6,00	6	82	44	35	36	SCD610-0600-2-4-140HA05-HP358	31052661
6,40	8	91	53	43	36	SCD610-0640-2-4-140HA05-HP358	31052665
6,50	8	91	53	43	36	SCD610-0650-2-4-140HA05-HP358	31052666
6,80	8	91	53	43	36	SCD610-0680-2-4-140HA05-HP358	31052669
6,90	8	91	53	43	36	SCD610-0690-2-4-140HA05-HP358	31052670
7,00	8	91	53	43	36	SCD610-0700-2-4-140HA05-HP358	31052671
7,40	8	91	53	43	36	SCD610-0740-2-4-140HA05-HP358	31052675
7,50	8	91	53	43	36	SCD610-0750-2-4-140HA05-HP358	31052676
7,80	8	91	53	43	36	SCD610-0780-2-4-140HA05-HP358	31052679
8,00	8	91	53	43	36	SCD610-0800-2-4-140HA05-HP358	31052681
8,50	10	103	61	49	40	SCD610-0850-2-4-140HA05-HP358	31052686
8,60	10	103	61	49	40	SCD610-0860-2-4-140HA05-HP358	31052687
8,80	10	103	61	49	40	SCD610-0880-2-4-140HA05-HP358	31052689
9,00	10	103	61	49	40	SCD610-0900-2-4-140HA05-HP358	31052691
9,50	10	103	61	49	40	SCD610-0950-2-4-140HA05-HP358	31052696
9,80	10	103	61	49	40	SCD610-0980-2-4-140HA05-HP358	31052699
10,00	10	103	61	49	40	SCD610-1000-2-4-140HA05-HP358	31052701

MEGA-Quadro-Drill-Plus | Punta elicoidale in metallo duro integrale SCD610 (5xD), adduzione esterna del refrigerante

Dimensioni						Forma del codolo HA	
d ₁ k7	d ₂ h6	l ₁	l ₂	l ₃	l ₄	Specifiche	Codice
10,20	12	118	71	56	45	SCD610-1020-2-4-140HA05-HP358	31052703
10,30	12	118	71	56	45	SCD610-1030-2-4-140HA05-HP358	31052704
10,50	12	118	71	56	45	SCD610-1050-2-4-140HA05-HP358	31052706
10,90	12	118	71	56	45	SCD610-1090-2-4-140HA05-HP358	31052710
11,00	12	118	71	56	45	SCD610-1100-2-4-140HA05-HP358	31052711
11,50	12	118	71	56	45	SCD610-1150-2-4-140HA05-HP358	31052716
11,80	12	118	71	56	45	SCD610-1180-2-4-140HA05-HP358	31052719
12,00	12	118	71	56	45	SCD610-1200-2-4-140HA05-HP358	31052721
12,50	14	124	77	60	45	SCD610-1250-2-4-140HA05-HP358	31052722
13,00	14	124	77	60	45	SCD610-1300-2-4-140HA05-HP358	31052724
13,50	14	124	77	60	45	SCD610-1350-2-4-140HA05-HP358	31052725
14,00	14	124	77	60	45	SCD610-1400-2-4-140HA05-HP358	31052727
14,50	16	133	83	63	48	SCD610-1450-2-4-140HA05-HP358	31052728
15,00	16	133	83	63	48	SCD610-1500-2-4-140HA05-HP358	31052730
16,00	16	133	83	63	48	SCD610-1600-2-4-140HA05-HP358	31052733
17,00	18	143	93	71	48	SCD610-1700-2-4-140HA05-HP358	31052736
17,50	18	143	93	71	48	SCD610-1750-2-4-140HA05-HP358	31052737
18,00	18	143	93	71	48	SCD610-1800-2-4-140HA05-HP358	31052739
18,50	20	153	101	77	50	SCD610-1850-2-4-140HA05-HP358	31052740
20,00	20	153	101	77	50	SCD610-2000-2-4-140HA05-HP358	31052745

Caratteristiche configurabili

**Diametro:**

Diametro a libera scelta a passi da 0,01 mm

**Forma del codolo:**

Forma del codolo: HB | HE

Specifiche:

SCD610-[diametro]-3-3-140[forma del codolo]05-HP358

Dimensioni serie configurabile

d ₁ min.	d ₁ max.	d ₂ h6	l ₁	l ₂	l ₃	l ₄
3,00	3,70	6	66	28	23	36
3,71	4,70	6	74	36	29	36
4,71	6,00	6	82	44	35	36
6,01	8,00	8	91	53	43	36
8,01	10,00	10	103	61	49	40
10,01	12,00	12	118	71	56	45
12,01	14,00	14	124	77	60	45
14,01	16,00	16	133	83	63	48
16,01	18,00	18	143	93	71	48
18,01	20,00	20	153	101	77	50

Esempio:

SCD610-0431-3-3-140HE05-HP358

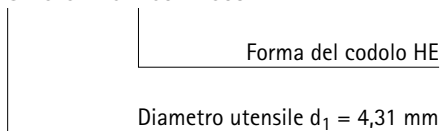

Dimensioni in mm.

Per informazioni e la ricerca di soluzioni si consiglia di consultare il capitolo.
Specifiche e prezzi sono disponibili su richiesta.

MEGA-Quadro-Drill-Plus

Punta elicoidale in metallo duro integrale

SCD611 (5xD), adduzione interna del refrigerante, prodotto successivo a MEGA-Quadro-Drill (SCD16)

Versione:

Diametro punta: 3,00 – 20,00 mm
 Tolleranza di foratura: \geq IT 8
 Materiale da taglio: HP358
 Numero di taglienti: 2
 Numero margini di guida: 4
 Angolo tra taglienti: 140°
 Angolo dell'elica: 30°

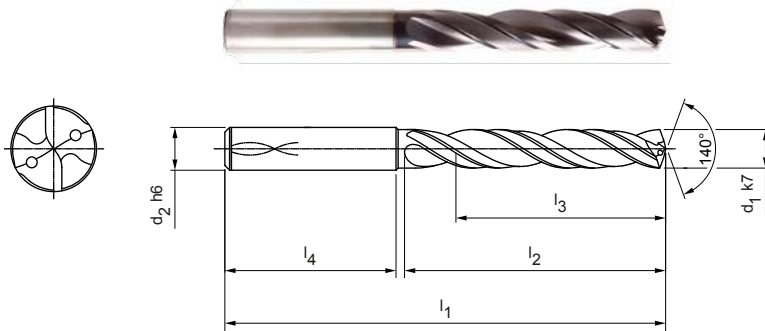

Serie selezionata per il magazzino con forma del codolo HA

Dimensioni						Forma del codolo HA	
d ₁ k7	d ₂ h6	l ₁	l ₂	l ₃	l ₄	Specifiche	Codice
3,00	6	66	28	23	36	SCD611-0300-2-4-140HA05-HP358	31052795
3,10	6	66	28	23	36	SCD611-0310-2-4-140HA05-HP358	31052796
3,20	6	66	28	23	36	SCD611-0320-2-4-140HA05-HP358	31052797
3,30	6	66	28	23	36	SCD611-0330-2-4-140HA05-HP358	31052798
3,40	6	66	28	23	36	SCD611-0340-2-4-140HA05-HP358	31052799
3,50	6	66	28	23	36	SCD611-0350-2-4-140HA05-HP358	31052800
3,70	6	66	28	23	36	SCD611-0370-2-4-140HA05-HP358	31052802
3,80	6	74	36	29	36	SCD611-0380-2-4-140HA05-HP358	31052803
3,90	6	74	36	29	36	SCD611-0390-2-4-140HA05-HP358	31052804
4,00	6	74	36	29	36	SCD611-0400-2-4-140HA05-HP358	31052805
4,20	6	74	36	29	36	SCD611-0420-2-4-140HA05-HP358	31052807
4,30	6	74	36	29	36	SCD611-0430-2-4-140HA05-HP358	31052808
4,50	6	74	36	29	36	SCD611-0450-2-4-140HA05-HP358	31052810
4,80	6	82	44	35	36	SCD611-0480-2-4-140HA05-HP358	31052813
5,00	6	82	44	35	36	SCD611-0500-2-4-140HA05-HP358	31052815
5,10	6	82	44	35	36	SCD611-0510-2-4-140HA05-HP358	31052816
5,20	6	82	44	35	36	SCD611-0520-2-4-140HA05-HP358	31052817
5,30	6	82	44	35	36	SCD611-0530-2-4-140HA05-HP358	31052818
5,50	6	82	44	35	36	SCD611-0550-2-4-140HA05-HP358	31052820
5,60	6	82	44	35	36	SCD611-0560-2-4-140HA05-HP358	31052821
5,80	6	82	44	35	36	SCD611-0580-2-4-140HA05-HP358	31052823
5,90	6	82	44	35	36	SCD611-0590-2-4-140HA05-HP358	31052824
6,00	6	82	44	35	36	SCD611-0600-2-4-140HA05-HP358	31052825
6,40	8	91	53	43	36	SCD611-0640-2-4-140HA05-HP358	31052829
6,50	8	91	53	43	36	SCD611-0650-2-4-140HA05-HP358	31052830
6,60	8	91	53	43	36	SCD611-0660-2-4-140HA05-HP358	31052831
6,70	8	91	53	43	36	SCD611-0670-2-4-140HA05-HP358	31052832
6,80	8	91	53	43	36	SCD611-0680-2-4-140HA05-HP358	31052833
6,90	8	91	53	43	36	SCD611-0690-2-4-140HA05-HP358	31052834
7,00	8	91	53	43	36	SCD611-0700-2-4-140HA05-HP358	31052835
7,20	8	91	53	43	36	SCD611-0720-2-4-140HA05-HP358	31052837
7,40	8	91	53	43	36	SCD611-0740-2-4-140HA05-HP358	31052839
7,50	8	91	53	43	36	SCD611-0750-2-4-140HA05-HP358	31052840
7,80	8	91	53	43	36	SCD611-0780-2-4-140HA05-HP358	31052843
7,90	8	91	53	43	36	SCD611-0790-2-4-140HA05-HP358	31052844

MEGA-Quadro-Drill-Plus | Punta elicoidale in metallo duro integrale SCD611 (5xD), adduzione interna del refrigerante

Dimensioni						Forma del codolo HA	
d ₁ k7	d ₂ h6	l ₁	l ₂	l ₃	l ₄	Specifiche	Codice
8,00	8	91	53	43	36	SCD611-0800-2-4-140HA05-HP358	31052845
8,10	10	103	61	49	40	SCD611-0810-2-4-140HA05-HP358	31052846
8,30	10	103	61	49	40	SCD611-0830-2-4-140HA05-HP358	31052848
8,40	10	103	61	49	40	SCD611-0840-2-4-140HA05-HP358	31052849
8,50	10	103	61	49	40	SCD611-0850-2-4-140HA05-HP358	31052850
8,60	10	103	61	49	40	SCD611-0860-2-4-140HA05-HP358	31052851
8,80	10	103	61	49	40	SCD611-0880-2-4-140HA05-HP358	31052853
9,00	10	103	61	49	40	SCD611-0900-2-4-140HA05-HP358	31052855
9,20	10	103	61	49	40	SCD611-0920-2-4-140HA05-HP358	31052857
9,30	10	103	61	49	40	SCD611-0930-2-4-140HA05-HP358	31052858
9,50	10	103	61	49	40	SCD611-0950-2-4-140HA05-HP358	31052860
9,80	10	103	61	49	40	SCD611-0980-2-4-140HA05-HP358	31052863
9,90	10	103	61	49	40	SCD611-0990-2-4-140HA05-HP358	31052864
10,00	10	103	61	49	40	SCD611-1000-2-4-140HA05-HP358	31052865
10,20	12	118	71	56	45	SCD611-1020-2-4-140HA05-HP358	31052867
10,30	12	118	71	56	45	SCD611-1030-2-4-140HA05-HP358	31052868
10,40	12	118	71	56	45	SCD611-1040-2-4-140HA05-HP358	31052869
10,50	12	118	71	56	45	SCD611-1050-2-4-140HA05-HP358	31052870
10,90	12	118	71	56	45	SCD611-1090-2-4-140HA05-HP358	31052874
11,00	12	118	71	56	45	SCD611-1100-2-4-140HA05-HP358	31052875
11,50	12	118	71	56	45	SCD611-1150-2-4-140HA05-HP358	31052880
11,70	12	118	71	56	45	SCD611-1170-2-4-140HA05-HP358	31052882
11,80	12	118	71	56	45	SCD611-1180-2-4-140HA05-HP358	31052883

Caratteristiche configurabili

**Diametro:**

Diametro a libera scelta a passi da 0,01 mm

**Forma del codolo:**

Forma del codolo: HB | HE

Specifiche:

SCD611-[diametro]-3-3-140[forma del codolo]05-HP358

Dimensioni serie configurabile

d ₁ min.	d ₁ max.	d ₂ h6	l ₁	l ₂	l ₃	l ₄
3,00	3,70	6	66	28	23	36
3,71	4,70	6	74	36	29	36
4,71	6,00	6	82	44	35	36
6,01	8,00	8	91	53	43	36
8,01	10,00	10	103	61	49	40
10,01	12,00	12	118	71	56	45
12,01	14,00	14	124	77	60	45
14,01	16,00	16	133	83	63	48
16,01	18,00	18	143	93	71	48
18,01	20,00	20	153	101	77	50

Esempio:

SCD611-0431-3-3-140HE05-HP358

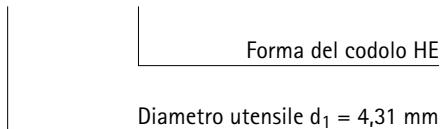

Misure in mm.

Per i parametri di lavorazione consigliati, vedere la fine del capitolo.

Versioni speciali e altri rivestimenti disponibili su richiesta.

MEGA-Quadro-Drill-Plus

Punta elicoidale in metallo duro integrale

SCD611 (8xD), adduzione interna del refrigerante, prodotto successivo a MEGA-Quadro-Drill (SCD16)

Versione:

Diametro punta: 3,00 – 20,00 mm
 Tolleranza di foratura: \geq IT 8
 Materiale da taglio: HP358
 Numero di taglianti: 2
 Numero margini di guida: 4
 Angolo tra taglianti: 140°
 Angolo dell'elica: 30°

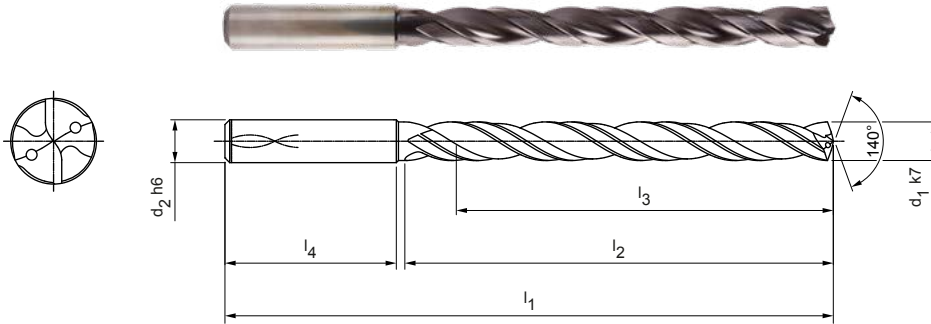

Serie selezionata per il magazzino con forma del codolo HA

Dimensioni						Forma del codolo HA	
d ₁ k7	d ₂ h6	l ₁	l ₂	l ₃	l ₄	Specifiche	Codice
3,00	6	72	34	29	36	SCD611-0300-2-4-140HA08-HP358	31052910
3,10	6	72	34	29	36	SCD611-0310-2-4-140HA08-HP358	31052911
3,20	6	72	34	29	36	SCD611-0320-2-4-140HA08-HP358	31052912
3,30	6	72	34	29	36	SCD611-0330-2-4-140HA08-HP358	31052913
3,40	6	72	34	29	36	SCD611-0340-2-4-140HA08-HP358	31052914
3,50	6	72	34	29	36	SCD611-0350-2-4-140HA08-HP358	31052915
3,60	6	72	34	29	36	SCD611-0360-2-4-140HA08-HP358	31052916
3,70	6	72	34	29	36	SCD611-0370-2-4-140HA08-HP358	31052917
3,80	6	81	43	36	36	SCD611-0380-2-4-140HA08-HP358	31052918
3,90	6	81	43	36	36	SCD611-0390-2-4-140HA08-HP358	31052919
4,00	6	81	43	36	36	SCD611-0400-2-4-140HA08-HP358	31052920
4,10	6	81	43	36	36	SCD611-0410-2-4-140HA08-HP358	31052921
4,20	6	81	43	36	36	SCD611-0420-2-4-140HA08-HP358	31052922
4,30	6	81	43	36	36	SCD611-0430-2-4-140HA08-HP358	31052923
4,40	6	81	43	36	36	SCD611-0440-2-4-140HA08-HP358	31052924
4,50	6	81	43	36	36	SCD611-0450-2-4-140HA08-HP358	31052925
4,60	6	81	43	36	36	SCD611-0460-2-4-140HA08-HP358	31052926
4,80	6	95	57	48	36	SCD611-0480-2-4-140HA08-HP358	31052928
4,90	6	95	57	48	36	SCD611-0490-2-4-140HA08-HP358	31052929
5,00	6	95	57	48	36	SCD611-0500-2-4-140HA08-HP358	31052930
5,10	6	95	57	48	36	SCD611-0510-2-4-140HA08-HP358	31052931
5,20	6	95	57	48	36	SCD611-0520-2-4-140HA08-HP358	31052932
5,40	6	95	57	48	36	SCD611-0540-2-4-140HA08-HP358	31052934
5,50	6	95	57	48	36	SCD611-0550-2-4-140HA08-HP358	31052935
5,60	6	95	57	48	36	SCD611-0560-2-4-140HA08-HP358	31052936
5,70	6	95	57	48	36	SCD611-0570-2-4-140HA08-HP358	31052937
5,80	6	95	57	48	36	SCD611-0580-2-4-140HA08-HP358	31052938
6,00	6	95	57	48	36	SCD611-0600-2-4-140HA08-HP358	31052940
6,10	8	114	76	64	36	SCD611-0610-2-4-140HA08-HP358	31052941
6,20	8	114	76	64	36	SCD611-0620-2-4-140HA08-HP358	31052942
6,50	8	114	76	64	36	SCD611-0650-2-4-140HA08-HP358	31052945
6,60	8	114	76	64	36	SCD611-0660-2-4-140HA08-HP358	31052946
6,80	8	114	76	64	36	SCD611-0680-2-4-140HA08-HP358	31052948
6,90	8	114	76	64	36	SCD611-0690-2-4-140HA08-HP358	31052949
7,00	8	114	76	64	36	SCD611-0700-2-4-140HA08-HP358	31052950

MEGA-Quadro-Drill-Plus | Punta elicoidale in metallo duro integrale SCD611 (8xD), adduzione interna del refrigerante

Dimensioni						Forma del codolo HA	
d ₁ k7	d ₂ h6	l ₁	l ₂	l ₃	l ₄	Specifiche	Codice
7,20	8	114	76	64	36	SCD611-0720-2-4-140HA08-HP358	31052952
7,40	8	114	76	64	36	SCD611-0740-2-4-140HA08-HP358	31052954
7,50	8	114	76	64	36	SCD611-0750-2-4-140HA08-HP358	31052955
7,60	8	114	76	64	36	SCD611-0760-2-4-140HA08-HP358	31052956
7,80	8	114	76	64	36	SCD611-0780-2-4-140HA08-HP358	31052958
8,00	8	114	76	64	36	SCD611-0800-2-4-140HA08-HP358	31052960
8,20	10	142	95	80	40	SCD611-0820-2-4-140HA08-HP358	31052962
8,50	10	142	95	80	40	SCD611-0850-2-4-140HA08-HP358	31052965
8,60	10	142	95	80	40	SCD611-0860-2-4-140HA08-HP358	31052966
8,70	10	142	95	80	40	SCD611-0870-2-4-140HA08-HP358	31052967
8,90	10	142	95	80	40	SCD611-0890-2-4-140HA08-HP358	31052969
9,00	10	142	95	80	40	SCD611-0900-2-4-140HA08-HP358	31052970
9,50	10	142	95	80	40	SCD611-0950-2-4-140HA08-HP358	31052975
9,60	10	142	95	80	40	SCD611-0960-2-4-140HA08-HP358	31052976
9,70	10	142	95	80	40	SCD611-0970-2-4-140HA08-HP358	31052977
9,80	10	142	95	80	40	SCD611-0980-2-4-140HA08-HP358	31052978
9,90	10	142	95	80	40	SCD611-0990-2-4-140HA08-HP358	31052979
10,00	10	142	95	80	40	SCD611-1000-2-4-140HA08-HP358	31052980
10,10	12	162	114	96	45	SCD611-1010-2-4-140HA08-HP358	31052981
10,20	12	162	114	96	45	SCD611-1020-2-4-140HA08-HP358	31052982
10,50	12	162	114	96	45	SCD611-1050-2-4-140HA08-HP358	31052985
10,60	12	162	114	96	45	SCD611-1060-2-4-140HA08-HP358	31052986
10,70	12	162	114	96	45	SCD611-1070-2-4-140HA08-HP358	31052987
11,00	12	162	114	96	45	SCD611-1100-2-4-140HA08-HP358	31052990
11,30	12	162	114	96	45	SCD611-1130-2-4-140HA08-HP358	31052993
11,70	12	162	114	96	45	SCD611-1170-2-4-140HA08-HP358	31052997
11,80	12	162	114	96	45	SCD611-1180-2-4-140HA08-HP358	31052998
12,00	12	162	114	96	45	SCD611-1200-2-4-140HA08-HP358	31053000
12,50	14	178	133	112	45	SCD611-1250-2-4-140HA08-HP358	31053001
12,80	14	178	133	112	45	SCD611-1280-2-4-140HA08-HP358	31053002
13,00	14	178	133	112	45	SCD611-1300-2-4-140HA08-HP358	31053003
13,50	14	178	133	112	45	SCD611-1350-2-4-140HA08-HP358	31053004
14,00	14	178	133	112	45	SCD611-1400-2-4-140HA08-HP358	31053006
15,00	16	203	152	128	48	SCD611-1500-2-4-140HA08-HP358	31053009
15,80	16	203	152	128	48	SCD611-1580-2-4-140HA08-HP358	31053011
16,00	16	203	152	128	48	SCD611-1600-2-4-140HA08-HP358	31053012
16,50	18	222	171	144	48	SCD611-1650-2-4-140HA08-HP358	31053013
20,00	20	243	190	160	50	SCD611-2000-2-4-140HA08-HP358	31053024

Caratteristiche configurabili

**Diametro:**

Diametro a libera scelta a passi da 0,01 mm

**Forma del codolo:**

Forma del codolo: HB | HE

Specifiche:

SCD611-[diametro]-3-3-140[forma del codolo]08-HP358

Dimensioni serie configurabile

d ₁ min.	d ₁ max.	d ₂ h6	l ₁	l ₂	l ₃	l ₄
3,00	3,70	6	72	34	29	36
3,71	4,70	6	81	43	36	36
4,71	6,00	6	95	57	48	36
6,01	8,00	8	114	76	64	36
8,01	10,00	10	142	95	80	40
10,01	12,00	12	162	114	96	45
12,01	14,00	14	178	133	112	45
14,01	16,00	16	203	152	128	48
16,01	18,00	18	222	171	144	48
18,01	20,00	20	243	190	160	50

Esempio:

SCD611-0431-2-4-140HE08-HP358

Forma del codolo HE

Diametro utensile d₁ = 4,31 mm

Misure in mm.

Per i parametri di lavorazione consigliati, vedere la fine del capitolo.
Versioni speciali e altri rivestimenti disponibili su richiesta.

MEGA-Quadro-Drill-Plus

Punta elicoidale in metallo duro integrale

SCD611 (12xD), adduzione interna del refrigerante, prodotto successivo a MEGA-Quadro-Drill (SCD16)

Versione:

Diametro punta: 3,00 – 20,00 mm
 Tolleranza di foratura: \geq IT 8
 Materiale da taglio: HP358
 Numero di taglienti: 2
 Numero margini di guida: 4
 Angolo tra taglienti: 140°
 Angolo dell'elica: 30°

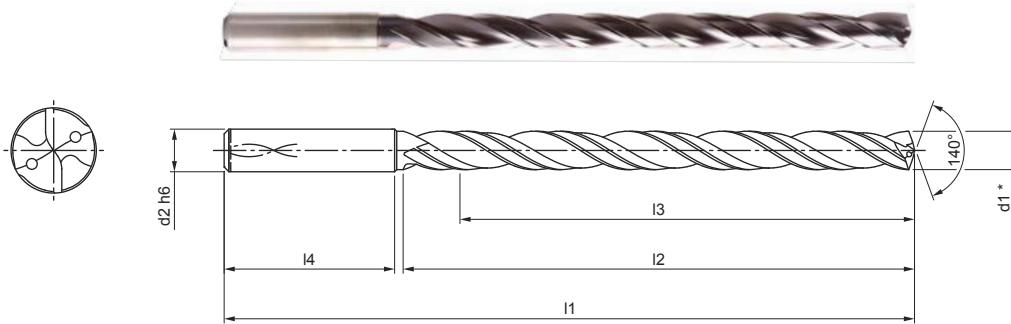

Serie selezionata per il magazzino con forma del codolo HA

Dimensioni						Forma del codolo HA	
d ₁ k7	d ₂ h6	l ₁	l ₂	l ₃	l ₄	Specifiche	Codice
3,00	6	92	54	48	36	SCD611-0300-2-4-140HA12-HP358	31053025
3,10	6	92	54	48	36	SCD611-0310-2-4-140HA12-HP358	31053026
3,20	6	92	54	48	36	SCD611-0320-2-4-140HA12-HP358	31053027
3,30	6	92	54	48	36	SCD611-0330-2-4-140HA12-HP358	31053028
3,40	6	92	54	48	36	SCD611-0340-2-4-140HA12-HP358	31053029
3,50	6	92	54	48	36	SCD611-0350-2-4-140HA12-HP358	31053030
3,60	6	92	54	48	36	SCD611-0360-2-4-140HA12-HP358	31053031
3,70	6	92	54	48	36	SCD611-0370-2-4-140HA12-HP358	31053032
3,80	6	102	64	58	36	SCD611-0380-2-4-140HA12-HP358	31053033
3,90	6	102	64	58	36	SCD611-0390-2-4-140HA12-HP358	31053034
4,00	6	102	64	58	36	SCD611-0400-2-4-140HA12-HP358	31053035
4,05	6	102	64	58	36	SCD611-0405-2-4-140HA12-HP358	31300718
4,10	6	102	64	58	36	SCD611-0410-2-4-140HA12-HP358	31053036
4,20	6	102	64	58	36	SCD611-0420-2-4-140HA12-HP358	31053037
4,30	6	102	64	58	36	SCD611-0430-2-4-140HA12-HP358	31053038
4,40	6	102	64	58	36	SCD611-0440-2-4-140HA12-HP358	31053039
4,50	6	102	64	58	36	SCD611-0450-2-4-140HA12-HP358	31053040
4,60	6	102	64	58	36	SCD611-0460-2-4-140HA12-HP358	31053041
4,65	6	116	78	58	36	SCD611-0465-2-4-140HA12-HP358	31179333
4,70	6	102	64	58	36	SCD611-0470-2-4-140HA12-HP358	31053042
4,80	6	116	78	70	36	SCD611-0480-2-4-140HA12-HP358	31053043
5,00	6	116	78	70	36	SCD611-0500-2-4-140HA12-HP358	31053045
5,05	6	116	78	70	36	SCD611-0505-2-4-140HA12-HP358	31245107
5,10	6	116	78	70	36	SCD611-0510-2-4-140HA12-HP358	31053046
5,20	6	116	78	70	36	SCD611-0520-2-4-140HA12-HP358	31053047
5,40	6	116	78	70	36	SCD611-0540-2-4-140HA12-HP358	31053049
5,50	6	116	78	70	36	SCD611-0550-2-4-140HA12-HP358	31053050
5,60	6	116	78	70	36	SCD611-0560-2-4-140HA12-HP358	31053051
5,70	6	116	78	70	36	SCD611-0570-2-4-140HA12-HP358	31053052
5,80	6	116	78	70	36	SCD611-0580-2-4-140HA12-HP358	31053053
6,00	6	116	78	70	36	SCD611-0600-2-4-140HA12-HP358	31053055
6,10	8	146	108	94	36	SCD611-0610-2-4-140HA12-HP358	31053056
6,40	8	146	108	94	36	SCD611-0640-2-4-140HA12-HP358	31053059
6,50	8	146	108	94	36	SCD611-0650-2-4-140HA12-HP358	31053060
6,80	8	146	108	94	36	SCD611-0680-2-4-140HA12-HP358	31053063

MEGA-Quadro-Drill-Plus | Punta elicoidale in metallo duro integrale SCD611 (12xD), adduzione interna del refrigerante

Dimensioni						Forma del codolo HA	
d ₁ k7	d ₂ h6	l ₁	l ₂	l ₃	l ₄	Specifiche	Codice
6,90	8	146	108	94	36	SCD611-0690-2-4-140HA12-HP358	31053064
7,00	8	146	108	94	36	SCD611-0700-2-4-140HA12-HP358	31053065
7,10	8	146	108	94	36	SCD611-0710-2-4-140HA12-HP358	31053066
7,50	8	146	108	94	36	SCD611-0750-2-4-140HA12-HP358	31053070
7,60	8	146	108	94	36	SCD611-0760-2-4-140HA12-HP358	31053071
7,70	8	146	108	94	36	SCD611-0770-2-4-140HA12-HP358	31053072
7,80	8	146	108	94	36	SCD611-0780-2-4-140HA12-HP358	31053073
7,90	8	146	108	94	36	SCD611-0790-2-4-140HA12-HP358	31053074
8,00	8	146	108	94	36	SCD611-0800-2-4-140HA12-HP358	31053075
8,20	10	162	120	110	40	SCD611-0820-2-4-140HA12-HP358	31053077
8,30	10	162	120	110	40	SCD611-0830-2-4-140HA12-HP358	31053078
8,40	10	162	120	110	40	SCD611-0840-2-4-140HA12-HP358	31053079
8,50	10	162	120	110	40	SCD611-0850-2-4-140HA12-HP358	31053080
8,60	10	162	120	110	40	SCD611-0860-2-4-140HA12-HP358	31053081
8,70	10	162	120	110	40	SCD611-0870-2-4-140HA12-HP358	31053082
9,00	10	162	120	110	40	SCD611-0900-2-4-140HA12-HP358	31053085
9,50	10	162	120	110	40	SCD611-0950-2-4-140HA12-HP358	31053090
9,60	10	162	120	110	40	SCD611-0960-2-4-140HA12-HP358	31053091
9,80	10	162	120	110	40	SCD611-0980-2-4-140HA12-HP358	31053093
9,90	10	162	120	110	40	SCD611-0990-2-4-140HA12-HP358	31053094
10,00	10	162	120	110	40	SCD611-1000-2-4-140HA12-HP358	31053095
10,20	12	204	156	142	45	SCD611-1020-2-4-140HA12-HP358	31053097
10,50	12	204	156	142	45	SCD611-1050-2-4-140HA12-HP358	31053100
10,60	12	204	156	142	45	SCD611-1060-2-4-140HA12-HP358	31053101
11,00	12	204	156	142	45	SCD611-1100-2-4-140HA12-HP358	31053105
11,20	12	204	156	142	45	SCD611-1120-2-4-140HA12-HP358	31053107
11,70	12	204	156	142	45	SCD611-1170-2-4-140HA12-HP358	31053112
11,80	12	204	156	142	45	SCD611-1180-2-4-140HA12-HP358	31053113
12,00	12	204	156	142	45	SCD611-1200-2-4-140HA12-HP358	31053115
12,50	14	230	182	166	45	SCD611-1250-2-4-140HA12-HP358	31053116
13,00	14	230	182	166	45	SCD611-1300-2-4-140HA12-HP358	31053118
13,50	14	230	182	166	45	SCD611-1350-2-4-140HA12-HP358	31053119
14,00	14	230	182	166	45	SCD611-1400-2-4-140HA12-HP358	31053121
14,50	16	260	208	192	48	SCD611-1450-2-4-140HA12-HP358	31053122
15,00	16	260	208	192	48	SCD611-1500-2-4-140HA12-HP358	31053124
16,00	16	260	208	192	48	SCD611-1600-2-4-140HA12-HP358	31053127
16,50	18	285	234	216	48	SCD611-1650-2-4-140HA12-HP358	31053128
17,50	18	285	234	216	48	SCD611-1750-2-4-140HA12-HP358	31053131
19,50	20	310	258	240	50	SCD611-1950-2-4-140HA12-HP358	31053137

Prosegue alla pagina seguente.

MEGA-Quadro-Drill-Plus | Punta elicoidale in metallo duro integrale SCD611 (12xD), adduzione interna del refrigerante

Caratteristiche configurabili

**Diametro:**

Diametro a libera scelta a passi da 0,01 mm

**Forma del codolo:**

Forma del codolo: HB | HE

Specifiche:

SCD611-[diametro]-2-4-140[forma del codolo]12-HP358

Dimensioni serie configurabile

d ₁ min.	d ₁ max.	d ₂ h6	l ₁	l ₂	l ₃	l ₄
3,00	3,70	6	92	54	48	36
3,71	4,70	6	102	64	58	36
4,71	6,00	6	116	78	70	36
6,01	8,00	8	146	108	94	36
8,01	10,00	10	162	120	110	40
10,01	12,00	12	204	156	142	45
12,01	14,00	14	230	182	166	45
14,01	16,00	16	260	208	192	48
16,01	18,00	18	285	234	216	48
18,01	20,00	20	310	258	240	50

Esempio:

SCD611-0431-2-4-140HE12-HP358

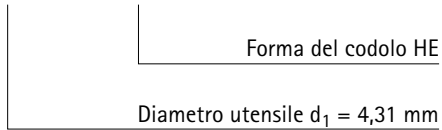

Misure in mm.

Per i parametri di lavorazione consigliati, vedere la fine del capitolo.

Versioni speciali e altri rivestimenti disponibili su richiesta.

MICRO-Drill-Steel

Punta elicoidale in metallo duro integrale
SCD371 (5xD), adduzione interna del refrigerante

Versione:

Diametro punta: 0,80 – 2,99 mm
Tolleranza di foratura: IT9 (raggiungibile)
Materiale da taglio: HP246
Numero di taglienti: 2
Numero margini di guida: 4
Angolo tra taglienti: 142°
Angolo dell'elica: 30°

Applicazione

Punta pilota specifica per MEGA-Deep-Drill.
Utilizzabile al massimo fino a < diametro
3,00 mm.

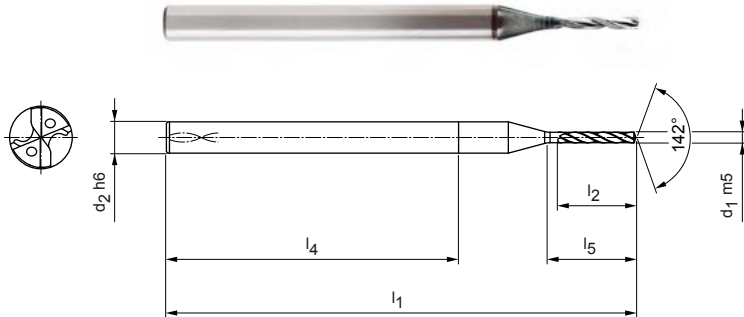

Serie selezionata per il magazzino con forma del codolo HA

Dimensioni						Forma del codolo HA	
d ₁ m5	d ₂ h6	l ₁	l ₂	l ₃	l ₄	Specifiche	Codice
0,80	3	45	6	4	28	SCD371-0080-2-4-142HA05-HP246	31238823
1,00	3	45	7,5	5	28	SCD371-0100-2-4-142HA05-HP246	31238825
1,20	3	45	9	6	28	SCD371-0120-2-4-142HA05-HP246	31238827
1,50	3	45	11,3	7,5	28	SCD371-0150-2-4-142HA05-HP246	31238890
1,60	3	50	12	8	28	SCD371-0160-2-4-142HA05-HP246	31238891
2,00	3	50	15	10	28	SCD371-0200-2-4-142HA05-HP246	31238895
2,40	3	52	18	12	28	SCD371-0240-2-4-142HA05-HP246	31238899
2,50	3	52	18,8	12,5	28	SCD371-0250-2-4-142HA05-HP246	31238900
2,60	3	55	19,5	13	28	SCD371-0260-2-4-142HA05-HP246	31238901
2,80	3	55	21	14	28	SCD371-0280-2-4-142HA05-HP246	31238903

Caratteristiche configurabili



Diametro:

Diametro a libera scelta a passi da
0,01 mm



Specifiche:

SCD371-[diametro]-2-4-142HA05-HP246

Dimensioni serie configurabile

d ₁ min.	d ₁ max.	d ₂ h6	l ₁	l ₂	l ₃	l ₄
0,80	0,99	3	45	6,0	4,0	28
1,00	1,29	3	45	7,5	5,0	28
1,30	1,59	3	45	9,8	6,5	28
1,60	1,89	3	50	12,0	8,0	28
1,90	2,19	3	50	14,3	9,5	28
2,20	2,59	3	52	16,5	11,0	28
2,60	2,99	3	55	19,5	13,0	28

Esempio:

SCD371-0221-2-4-142HA05-HP246

Diametro utensile d₁ = 2,21 mm

Misure in mm.

Per i parametri di lavorazione consigliati, vedere la fine del capitolo.

Versioni speciali e altri rivestimenti disponibili su richiesta.

MICRO-Drill-Steel

Punta elicoidale in metallo duro integrale
SCD371 (8xD), adduzione interna del refrigerante

Versione:

Diametro punta: 1,00 – 2,99 mm
Tolleranza di foratura: IT9 (raggiungibile)
Materiale da taglio: HP246
Numero di taglienti: 2
Numero margini di guida: 4
Angolo tra taglienti: 142°
Angolo dell'elica: 30°

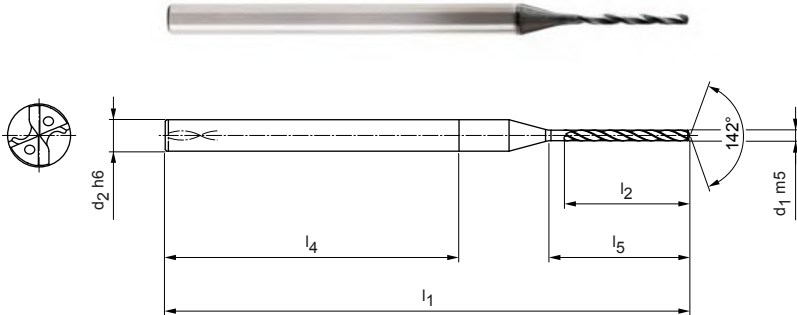

Serie selezionata per il magazzino con forma del codolo HA

Dimensioni						Forma del codolo HA	
d ₁ m5	d ₂ h6	l ₁	l ₂	l ₃	l ₄	Specifiche	Codice
1,00	3	50	12	8	28	SCD371-0100-2-4-142HA08-HP246	31238905
1,20	3	50	14,4	9,6	28	SCD371-0120-2-4-142HA08-HP246	31238907
1,50	3	52	18	12	28	SCD371-0150-2-4-142HA08-HP246	31238910
1,60	3	55	19,2	12,8	28	SCD371-0160-2-4-142HA08-HP246	31238911
2,00	3	60	24	16	28	SCD371-0200-2-4-142HA08-HP246	31238915
2,50	3	62	30	20	28	SCD371-0250-2-4-142HA08-HP246	31238920

Caratteristiche configurabili

Diametro:
Diametro a libera scelta a passi da 0,01 mm

Specifiche:
SCD371-[diametro]-2-4-142HA08-HP246

Dimensioni serie configurabile

d ₁ min.	d ₁ max.	d ₂ h6	l ₁	l ₂	l ₃	l ₄
1,00	1,29	3	50	12,0	8,0	28
1,30	1,59	3	52	15,6	10,4	28
1,60	1,89	3	55	19,2	12,8	28
1,90	2,19	3	60	22,8	15,2	28
2,20	2,59	3	62	26,4	17,6	28
2,60	2,99	3	66	31,2	20,8	28

Esempio:

SCD371-0221-2-4-142HA08-HP246

Diametro utensile d₁ = 2,21 mm

Misure in mm.

Per i parametri di lavorazione consigliati, vedere la fine del capitolo.

Versioni speciali e altri rivestimenti disponibili su richiesta.

MICRO-Drill-Steel

Punta elicoidale in metallo duro integrale
SCD371 (12xD), adduzione interna del refrigerante

Versione:

Diametro punta: 1,00 – 2,99 mm
Tolleranza di foratura: IT9 (raggiungibile)
Materiale da taglio: HP246
Numero di taglienti: 2
Numero margini di guida: 4
Angolo tra taglienti: 142°
Angolo dell'elica: 30°

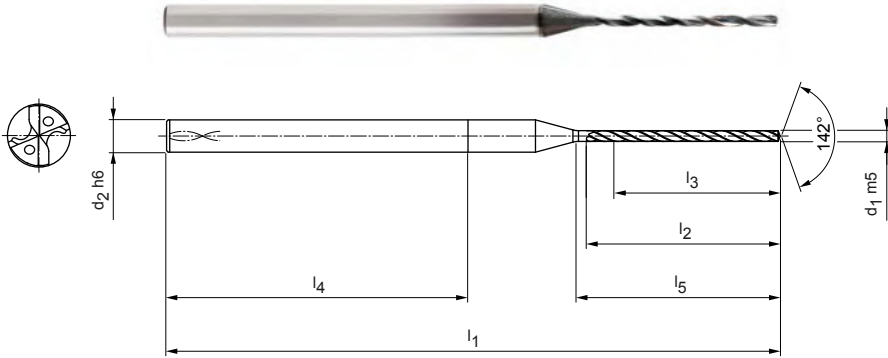

Serie selezionata per il magazzino con forma del codolo HA

Dimensioni						Forma del codolo HA	
d ₁ m5	d ₂ h6	l ₁	l ₂	l ₃	l ₄	Specifiche	Codice
1,00	3	57	18	12	28	SCD371-0100-2-4-142HA12-HP246	31238925
1,20	3	57	21,6	14,4	28	SCD371-0120-2-4-142HA12-HP246	31238927
1,30	3	62	23,4	15,6	28	SCD371-0130-2-4-142HA12-HP246	31238928
1,50	3	62	27	18	28	SCD371-0150-2-4-142HA12-HP246	31238930
2,00	3	72	36	24	28	SCD371-0200-2-4-142HA12-HP246	31238935
2,50	3	79	45	30	28	SCD371-0250-2-4-142HA12-HP246	31238940

Caratteristiche configurabili



Diametro:

Diametro a libera scelta a passi da 0,01 mm



Specifiche:

SCD371-[diametro]-2-4-142HA12-HP246

Dimensioni serie configurabile

d ₁ min.	d ₁ max.	d ₂ h6	l ₁	l ₂	l ₃	l ₄
1,00	1,29	3	57	18,0	12,0	28
1,30	1,59	3	62	23,4	15,6	28
1,60	1,89	3	66	28,8	19,2	28
1,90	2,19	3	72	34,2	22,8	28
2,20	2,59	3	79	39,6	26,4	28
2,60	2,99	3	85	46,8	31,2	28

Esempio:

SCD371-0221-2-4-142HA12-HP246

Diametro utensile d₁ = 2,21 mm

Misure in mm.

Per i parametri di lavorazione consigliati, vedere la fine del capitolo.

Versioni speciali e altri rivestimenti disponibili su richiesta.

MEGA-Drill-Hardened

Punta elicoidale in metallo duro integrale
SCD140 (3xD)

Versione:

Diametro punta: 2,55 – 20,00 mm
Tolleranza di foratura: IT 9 (raggiungibile)
Materiale da taglio: HP809
Numero di taglienti: 2
Numero margini di guida: 2
Angolo tra taglienti: 140°
Angolo dell'elica: 15°

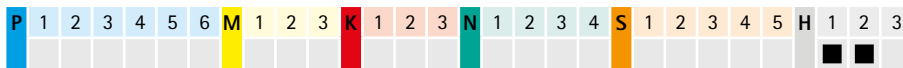
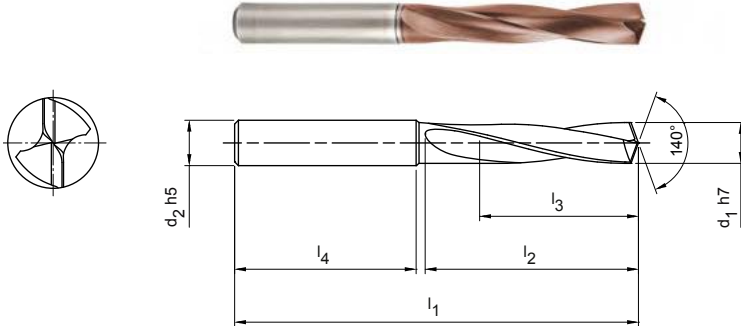
Serie selezionata per il magazzino con forma del codolo HA

Dimensioni						Forma del codolo HA	
d ₁ h7	d ₂ h5	l ₁	l ₂	l ₃	l ₄	Specifiche	Codice
2,55	6	62	20	14	36	SCD140-0255-2-2-140HA03-HP809	31198190
2,60	6	62	20	14	36	SCD140-0260-2-2-140HA03-HP809	31198191
2,70	6	62	20	14	36	SCD140-0270-2-2-140HA03-HP809	31198192
2,80	6	62	20	14	36	SCD140-0280-2-2-140HA03-HP809	31198194
2,90	6	62	20	14	36	SCD140-0290-2-2-140HA03-HP809	31198196
3,00	6	62	20	14	36	SCD140-0300-2-2-140HA03-HP809	31151191
3,10	6	62	20	14	36	SCD140-0310-2-2-140HA03-HP809	31151192
3,20	6	62	20	14	36	SCD140-0320-2-2-140HA03-HP809	31151193
3,30	6	62	20	14	36	SCD140-0330-2-2-140HA03-HP809	31151194
3,40	6	62	20	14	36	SCD140-0340-2-2-140HA03-HP809	31151195
3,50	6	62	20	14	36	SCD140-0350-2-2-140HA03-HP809	31151196
3,60	6	62	20	14	36	SCD140-0360-2-2-140HA03-HP809	31151197
3,70	6	62	20	14	36	SCD140-0370-2-2-140HA03-HP809	31151198
3,80	6	66	24	17	36	SCD140-0380-2-2-140HA03-HP809	31151199
3,90	6	66	24	17	36	SCD140-0390-2-2-140HA03-HP809	31151330
4,00	6	66	24	17	36	SCD140-0400-2-2-140HA03-HP809	31151331
4,10	6	66	24	17	36	SCD140-0410-2-2-140HA03-HP809	31151332
4,20	6	66	24	17	36	SCD140-0420-2-2-140HA03-HP809	31151333
4,30	6	66	24	17	36	SCD140-0430-2-2-140HA03-HP809	31151334
4,40	6	66	24	17	36	SCD140-0440-2-2-140HA03-HP809	31151335
4,50	6	66	24	17	36	SCD140-0450-2-2-140HA03-HP809	31151336
4,60	6	66	24	17	36	SCD140-0460-2-2-140HA03-HP809	31151337
4,70	6	66	24	17	36	SCD140-0470-2-2-140HA03-HP809	31151339
4,80	6	66	28	20	36	SCD140-0480-2-2-140HA03-HP809	31151340
4,90	6	66	28	20	36	SCD140-0490-2-2-140HA03-HP809	31151341
5,00	6	66	28	20	36	SCD140-0500-2-2-140HA03-HP809	31151342
5,10	6	66	28	20	36	SCD140-0510-2-2-140HA03-HP809	31151343
5,20	6	66	28	20	36	SCD140-0520-2-2-140HA03-HP809	31151344
5,30	6	66	28	20	36	SCD140-0530-2-2-140HA03-HP809	31151345
5,40	6	66	28	20	36	SCD140-0540-2-2-140HA03-HP809	31151346
5,50	6	66	28	20	36	SCD140-0550-2-2-140HA03-HP809	31151347
5,55	6	66	28	20	36	SCD140-0555-2-2-140HA03-HP809	31151348
5,60	6	66	28	20	36	SCD140-0560-2-2-140HA03-HP809	31151349
5,70	6	66	28	20	36	SCD140-0570-2-2-140HA03-HP809	31151350
5,80	6	66	28	20	36	SCD140-0580-2-2-140HA03-HP809	31151351

MEGA-Drill-Hardened | Punta elicoidale in metallo duro integrale SCD140 (3xD)

Dimensioni						Forma del codolo HA	
d ₁ h7	d ₂ h6	l ₁	l ₂	l ₃	l ₄	Specifiche	Codice
5,90	6	66	28	20	36	SCD140-0590-2-2-140HA03-HP809	31151352
6,00	6	66	28	20	36	SCD140-0600-2-2-140HA03-HP809	31151353
6,10	8	79	34	24	36	SCD140-0610-2-2-140HA03-HP809	31151354
6,20	8	79	34	24	36	SCD140-0620-2-2-140HA03-HP809	31151355
6,30	8	79	34	24	36	SCD140-0630-2-2-140HA03-HP809	31151356
6,40	8	79	34	24	36	SCD140-0640-2-2-140HA03-HP809	31151357
6,50	8	79	34	24	36	SCD140-0650-2-2-140HA03-HP809	31151358
6,60	8	79	34	24	36	SCD140-0660-2-2-140HA03-HP809	31151359
6,70	8	79	34	24	36	SCD140-0670-2-2-140HA03-HP809	31151360
6,80	8	79	34	24	36	SCD140-0680-2-2-140HA03-HP809	31151361
6,90	8	79	34	24	36	SCD140-0690-2-2-140HA03-HP809	31151362
7,00	8	79	34	24	36	SCD140-0700-2-2-140HA03-HP809	31151363
7,10	8	79	41	29	36	SCD140-0710-2-2-140HA03-HP809	31151364
7,30	8	79	41	29	36	SCD140-0730-2-2-140HA03-HP809	31151366
7,40	8	79	41	29	36	SCD140-0740-2-2-140HA03-HP809	31151367
7,50	8	79	41	29	36	SCD140-0750-2-2-140HA03-HP809	31151368
7,80	8	79	41	29	36	SCD140-0780-2-2-140HA03-HP809	31151371
7,90	8	79	41	29	36	SCD140-0790-2-2-140HA03-HP809	31151372
8,00	8	79	41	29	36	SCD140-0800-2-2-140HA03-HP809	31151373
8,10	10	89	47	35	40	SCD140-0810-2-2-140HA03-HP809	31151374
8,20	10	89	47	35	40	SCD140-0820-2-2-140HA03-HP809	31151375
8,50	10	89	47	35	40	SCD140-0850-2-2-140HA03-HP809	31151378
8,60	10	89	47	35	40	SCD140-0860-2-2-140HA03-HP809	31151379
8,80	10	89	47	35	40	SCD140-0880-2-2-140HA03-HP809	31151381
9,00	10	89	47	35	40	SCD140-0900-2-2-140HA03-HP809	31151383
9,30	10	89	47	35	40	SCD140-0930-2-2-140HA03-HP809	31151386
9,50	10	89	47	35	40	SCD140-0950-2-2-140HA03-HP809	31151388
9,60	10	89	47	35	40	SCD140-0960-2-2-140HA03-HP809	31151389
9,70	10	89	47	35	40	SCD140-0970-2-2-140HA03-HP809	31151390
9,80	10	89	47	35	40	SCD140-0980-2-2-140HA03-HP809	31151391
10,00	10	89	47	35	40	SCD140-1000-2-2-140HA03-HP809	31151393
10,10	12	102	55	40	45	SCD140-1010-2-2-140HA03-HP809	31151394
10,20	12	102	55	40	45	SCD140-1020-2-2-140HA03-HP809	31151395
10,30	12	102	55	40	45	SCD140-1030-2-2-140HA03-HP809	31151396
10,40	12	102	55	40	45	SCD140-1040-2-2-140HA03-HP809	31151397
10,50	12	102	55	40	45	SCD140-1050-2-2-140HA03-HP809	31151398
11,00	12	102	55	40	45	SCD140-1100-2-2-140HA03-HP809	31151403
11,50	12	102	55	40	45	SCD140-1150-2-2-140HA03-HP809	31151408
11,80	12	102	55	40	45	SCD140-1180-2-2-140HA03-HP809	31151411
11,90	12	102	55	40	45	SCD140-1190-2-2-140HA03-HP809	31151412
12,00	12	102	55	40	45	SCD140-1200-2-2-140HA03-HP809	31151413
12,50	14	107	60	43	45	SCD140-1250-2-2-140HA03-HP809	31151415
12,80	14	107	60	43	45	SCD140-1280-2-2-140HA03-HP809	31151416
13,00	14	107	60	43	45	SCD140-1300-2-2-140HA03-HP809	31151417
13,50	14	107	60	43	45	SCD140-1350-2-2-140HA03-HP809	31151418
14,00	14	107	60	43	45	SCD140-1400-2-2-140HA03-HP809	31151420
14,20	16	115	65	45	48	SCD140-1420-2-2-140HA03-HP809	31151421
14,50	16	115	65	45	48	SCD140-1450-2-2-140HA03-HP809	31151422
14,80	16	115	65	45	48	SCD140-1480-2-2-140HA03-HP809	31151423
15,00	16	115	65	45	48	SCD140-1500-2-2-140HA03-HP809	31151424
15,50	16	115	65	45	48	SCD140-1550-2-2-140HA03-HP809	31151426
16,00	16	115	65	45	48	SCD140-1600-2-2-140HA03-HP809	31151428
17,50	18	123	73	51	48	SCD140-1750-2-2-140HA03-HP809	31151432

Prosegue alla pagina seguente.

MEGA-Drill-Hardened | Punta elicoidale in metallo duro integrale SCD140 (3xD)

Caratteristiche configurabili

**Diametro:**

Diametro a libera scelta a passi da 0,01 mm

**Forma del codolo:**

Forma del codolo: HB | HE

Specifiche:

SCD140-[diametro]-2-2-140[forma del codolo]03-HP809

Dimensioni serie configurabile

d ₁ min.	d ₁ max.	d ₂ h6	l ₁	l ₂	l ₃	l ₄
2,55	3,79	6	62	20	14	36
3,80	4,79	6	66	24	17	36
4,80	6,00	6	66	28	20	36
6,01	7,00	8	79	34	24	36
7,01	8,00	8	79	41	29	36
8,01	10,00	10	89	47	35	40
10,01	12,00	12	102	55	40	45
12,01	14,00	14	107	60	43	45
14,01	16,00	16	115	65	45	48
16,01	18,00	18	123	73	51	48
18,01	20,00	20	131	79	55	50

Esempio:

SCD140-0431-2-2-140HE03-HP809

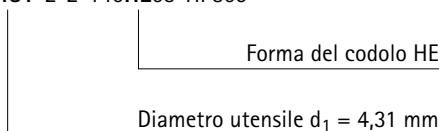

Misure in mm.

Per i parametri di lavorazione consigliati, vedere la fine del capitolo.

Versioni speciali e altri rivestimenti disponibili su richiesta.

Tritan-Drill-Steel

Punta elicoidale in metallo duro integrale
SCD661 (3xD), adduzione interna del refrigerante

Versione:

Diametro punta: 4,00 – 20,00 mm
Tolleranza di foratura: \geq IT 9
Materiale da taglio: HP358
Numero di taglienti: 3
Numero margini di guida: 3
Angolo tra taglienti: 145°
Angolo dell'elica: 30°

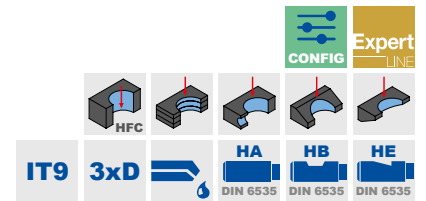
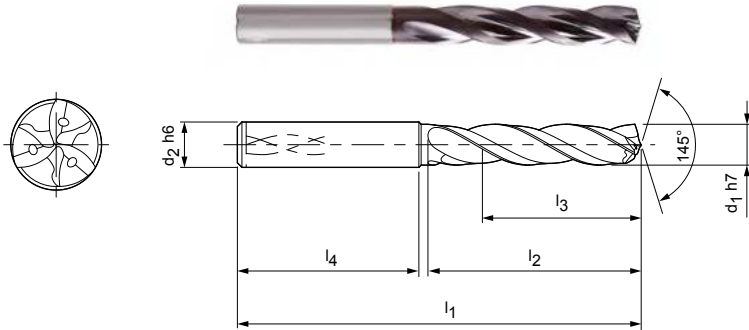

Serie selezionata per il magazzino con forma del codolo HA

Dimensioni						Forma del codolo HA	
d ₁ h7	d ₂ h6	l ₁	l ₂	l ₃	l ₄	Specifiche	Codice
4,00	6	66	24	17	36	SCD661-0400-3-3-145HA03-HP358	30902036
4,10	6	66	24	17	36	SCD661-0410-3-3-145HA03-HP358	30902037
4,20	6	66	24	17	36	SCD661-0420-3-3-145HA03-HP358	30902038
4,30	6	66	24	17	36	SCD661-0430-3-3-145HA03-HP358	30902039
4,40	6	66	24	17	36	SCD661-0440-3-3-145HA03-HP358	30902040
4,50	6	66	24	17	36	SCD661-0450-3-3-145HA03-HP358	30902041
4,60	6	66	24	17	36	SCD661-0460-3-3-145HA03-HP358	30902042
4,65	6	66	24	17	36	SCD661-0465-3-3-145HA03-HP358	30902043
4,70	6	66	24	17	36	SCD661-0470-3-3-145HA03-HP358	30902044
4,80	6	66	28	20	36	SCD661-0480-3-3-145HA03-HP358	30902045
4,90	6	66	28	20	36	SCD661-0490-3-3-145HA03-HP358	30902046
5,00	6	66	28	20	36	SCD661-0500-3-3-145HA03-HP358	30902047
5,10	6	66	28	20	36	SCD661-0510-3-3-145HA03-HP358	30902048
5,20	6	66	28	20	36	SCD661-0520-3-3-145HA03-HP358	30902049
5,30	6	66	28	20	36	SCD661-0530-3-3-145HA03-HP358	30902050
5,40	6	66	28	20	36	SCD661-0540-3-3-145HA03-HP358	30902051
5,50	6	66	28	20	36	SCD661-0550-3-3-145HA03-HP358	30902052
5,55	6	66	28	20	36	SCD661-0555-3-3-145HA03-HP358	30902053
5,60	6	66	28	20	36	SCD661-0560-3-3-145HA03-HP358	30902054
5,70	6	66	28	20	36	SCD661-0570-3-3-145HA03-HP358	30902055
5,80	6	66	28	20	36	SCD661-0580-3-3-145HA03-HP358	30902056
5,90	6	66	28	20	36	SCD661-0590-3-3-145HA03-HP358	30902057
6,00	6	66	28	20	36	SCD661-0600-3-3-145HA03-HP358	30902058
6,10	8	79	34	24	36	SCD661-0610-3-3-145HA03-HP358	30902059
6,20	8	79	34	24	36	SCD661-0620-3-3-145HA03-HP358	30902060
6,30	8	79	34	24	36	SCD661-0630-3-3-145HA03-HP358	30902061
6,35	8	79	34	24	36	SCD661-0635-3-3-145HA03-HP358	31307522
6,40	8	79	34	24	36	SCD661-0640-3-3-145HA03-HP358	30902062
6,50	8	79	34	24	36	SCD661-0650-3-3-145HA03-HP358	30902063
6,60	8	79	34	24	36	SCD661-0660-3-3-145HA03-HP358	30902064
6,70	8	79	34	24	36	SCD661-0670-3-3-145HA03-HP358	30902065
6,80	8	79	34	24	36	SCD661-0680-3-3-145HA03-HP358	30902066
6,90	8	79	34	24	36	SCD661-0690-3-3-145HA03-HP358	30902067
7,00	8	79	34	24	36	SCD661-0700-3-3-145HA03-HP358	30902068
7,10	8	79	41	29	36	SCD661-0710-3-3-145HA03-HP358	30902069

Tritan-Drill-Steel | Punta elicoidale in metallo duro integrale SCD661 (3xD), adduzione interna del refrigerante

Dimensioni						Forma del codolo HA	
d ₁ h7	d ₂ h6	l ₁	l ₂	l ₃	l ₄	Specifiche	Codice
7,20	8	79	41	29	36	SCD661-0720-3-3-145HA03-HP358	30902070
7,30	8	79	41	29	36	SCD661-0730-3-3-145HA03-HP358	30902071
7,40	8	79	41	29	36	SCD661-0740-3-3-145HA03-HP358	30902072
7,45	8	79	41	29	36	SCD661-0745-3-3-145HA03-HP358	30902073
7,50	8	79	41	29	36	SCD661-0750-3-3-145HA03-HP358	30902074
7,60	8	79	41	29	36	SCD661-0760-3-3-145HA03-HP358	30902075
7,70	8	79	41	29	36	SCD661-0770-3-3-145HA03-HP358	30902076
7,80	8	79	41	29	36	SCD661-0780-3-3-145HA03-HP358	30902077
7,90	8	79	41	29	36	SCD661-0790-3-3-145HA03-HP358	30902078
8,00	8	79	41	29	36	SCD661-0800-3-3-145HA03-HP358	30902079
8,10	10	89	47	35	40	SCD661-0810-3-3-145HA03-HP358	30902080
8,20	10	89	47	35	40	SCD661-0820-3-3-145HA03-HP358	30902081
8,30	10	89	47	35	40	SCD661-0830-3-3-145HA03-HP358	30902082
8,40	10	89	47	35	40	SCD661-0840-3-3-145HA03-HP358	30902083
8,50	10	89	47	35	40	SCD661-0850-3-3-145HA03-HP358	30902084
8,60	10	89	47	35	40	SCD661-0860-3-3-145HA03-HP358	30902085
8,70	10	89	47	35	40	SCD661-0870-3-3-145HA03-HP358	30902086
8,80	10	89	47	35	40	SCD661-0880-3-3-145HA03-HP358	30902087
9,00	10	89	47	35	40	SCD661-0900-3-3-145HA03-HP358	30902089
9,10	10	89	47	35	40	SCD661-0910-3-3-145HA03-HP358	30902090
9,20	10	89	47	35	40	SCD661-0920-3-3-145HA03-HP358	30902091
9,30	10	89	47	35	40	SCD661-0930-3-3-145HA03-HP358	30902092
9,35	10	89	47	35	40	SCD661-0935-3-3-145HA03-HP358	31307523
9,40	10	89	47	35	40	SCD661-0940-3-3-145HA03-HP358	30902093
9,50	10	89	47	35	40	SCD661-0950-3-3-145HA03-HP358	30902094
9,60	10	89	47	35	40	SCD661-0960-3-3-145HA03-HP358	30902095
9,70	10	89	47	35	40	SCD661-0970-3-3-145HA03-HP358	30902096
9,80	10	89	47	35	40	SCD661-0980-3-3-145HA03-HP358	30902097
9,90	10	89	47	35	40	SCD661-0990-3-3-145HA03-HP358	30902098
10,00	10	89	47	35	40	SCD661-1000-3-3-145HA03-HP358	30902099
10,10	12	102	55	40	45	SCD661-1010-3-3-145HA03-HP358	30902100
10,20	12	102	55	40	45	SCD661-1020-3-3-145HA03-HP358	30902101
10,30	12	102	55	40	45	SCD661-1030-3-3-145HA03-HP358	30902102
10,40	12	102	55	40	45	SCD661-1040-3-3-145HA03-HP358	30902103
10,50	12	102	55	40	45	SCD661-1050-3-3-145HA03-HP358	30902104
10,80	12	102	55	40	45	SCD661-1080-3-3-145HA03-HP358	30902107
10,90	12	102	55	40	45	SCD661-1090-3-3-145HA03-HP358	30902108
11,00	12	102	55	40	45	SCD661-1100-3-3-145HA03-HP358	30902109
11,10	12	102	55	40	45	SCD661-1110-3-3-145HA03-HP358	30902110
11,20	12	102	55	40	45	SCD661-1120-3-3-145HA03-HP358	30902111
11,30	12	102	55	40	45	SCD661-1130-3-3-145HA03-HP358	30902112
11,40	12	102	55	40	45	SCD661-1140-3-3-145HA03-HP358	30902113
11,50	12	102	55	40	45	SCD661-1150-3-3-145HA03-HP358	30902114
11,60	12	102	55	40	45	SCD661-1160-3-3-145HA03-HP358	30902115
11,70	12	102	55	40	45	SCD661-1170-3-3-145HA03-HP358	30902116
11,80	12	102	55	40	45	SCD661-1180-3-3-145HA03-HP358	30902117
11,90	12	102	55	40	45	SCD661-1190-3-3-145HA03-HP358	30902118
12,00	12	102	55	40	45	SCD661-1200-3-3-145HA03-HP358	30902119
12,20	14	107	60	43	45	SCD661-1220-3-3-145HA03-HP358	30902120
12,23	14	107	60	43	45	SCD661-1223-3-3-145HA03-HP358	31271441
12,50	14	107	60	43	45	SCD661-1250-3-3-145HA03-HP358	30902121
12,70	14	107	60	43	45	SCD661-1270-3-3-145HA03-HP358	31307524
13,00	14	107	60	43	45	SCD661-1300-3-3-145HA03-HP358	30902123
13,50	14	107	60	43	45	SCD661-1350-3-3-145HA03-HP358	30902125
13,80	14	107	60	43	45	SCD661-1380-3-3-145HA03-HP358	30902126
14,00	14	107	60	43	45	SCD661-1400-3-3-145HA03-HP358	30902127
14,20	16	115	65	45	48	SCD661-1420-3-3-145HA03-HP358	30902128

Tritan-Drill-Steel | Punta elicoidale in metallo duro integrale SCD661 (3xD), adduzione interna del refrigerante

Dimensioni						Forma del codolo HA	
d ₁ h7	d ₂ h6	l ₁	l ₂	l ₃	l ₄	Specifiche	Codice
14,50	16	115	65	45	48	SCD661-1450-3-3-145HA03-HP358	30902129
14,80	16	115	65	45	48	SCD661-1480-3-3-145HA03-HP358	30902130
15,00	16	115	65	45	48	SCD661-1500-3-3-145HA03-HP358	30902131
15,20	16	115	65	45	48	SCD661-1520-3-3-145HA03-HP358	30902132
15,50	16	115	65	45	48	SCD661-1550-3-3-145HA03-HP358	30902133
15,80	16	115	65	45	48	SCD661-1580-3-3-145HA03-HP358	30902134
16,00	16	115	65	45	48	SCD661-1600-3-3-145HA03-HP358	30902135
16,20	18	123	73	51	48	SCD661-1620-3-3-145HA03-HP358	30902136
16,50	18	123	73	51	48	SCD661-1650-3-3-145HA03-HP358	30902137
17,00	18	123	73	51	48	SCD661-1700-3-3-145HA03-HP358	30902139
17,35	18	123	73	51	48	SCD661-1735-3-3-145HA03-HP358	31307525
17,50	18	123	73	51	48	SCD661-1750-3-3-145HA03-HP358	30902141
17,80	18	123	73	51	48	SCD661-1780-3-3-145HA03-HP358	30902142
18,00	18	123	73	51	48	SCD661-1800-3-3-145HA03-HP358	30902143
18,50	20	131	79	55	50	SCD661-1850-3-3-145HA03-HP358	30902145
18,80	20	131	79	55	50	SCD661-1880-3-3-145HA03-HP358	30902146
19,00	20	131	79	55	50	SCD661-1900-3-3-145HA03-HP358	30902147
19,50	20	131	79	55	50	SCD661-1950-3-3-145HA03-HP358	30902149
20,00	20	131	79	55	50	SCD661-2000-3-3-145HA03-HP358	30902151

Caratteristiche configurabili

**Diametro:**

Diametro a libera scelta a passi da 0,01 mm

**Forma del codolo:**

Forma del codolo: HB | HE

**Specifiche:**

SCD661-[diametro]-3-3-140[forma del codolo]03-HP358

Dimensioni serie configurabile

d ₁ min.	d ₁ max.	d ₂ h6	l ₁	l ₂	l ₃	l ₄
4,00	4,70	6	66	24	17	36
4,71	6,00	6	66	28	20	36
6,01	7,00	8	79	34	24	36
7,01	8,00	8	79	41	29	36
8,01	10,00	10	89	47	35	40
10,01	12,00	12	102	55	40	45
12,01	14,00	14	107	60	43	45
14,01	16,00	16	115	65	45	48
16,01	18,00	18	123	73	51	48
18,01	20,00	20	131	79	55	50

Esempio:

SCD661-0431-3-3-140HE03-HP358

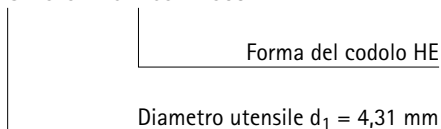

Misure in mm.

Per i parametri di lavorazione consigliati, vedere la fine del capitolo.

Versioni speciali e altri rivestimenti disponibili su richiesta.

Tritan-Drill-Steel

Punta elicoidale in metallo duro integrale
SCD661 (5xD), adduzione interna del refrigerante

Versione:

Diametro punta: 4,00 – 20,00 mm
Tolleranza di foratura: \geq IT 9
Materiale da taglio: HP358
Numero di taglienti: 3
Numero margini di guida: 3
Angolo tra taglienti: 145°
Angolo dell'elica: 30°

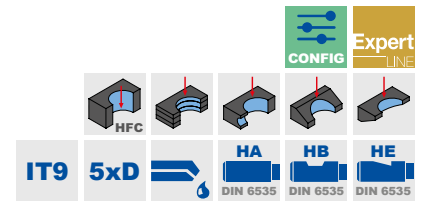
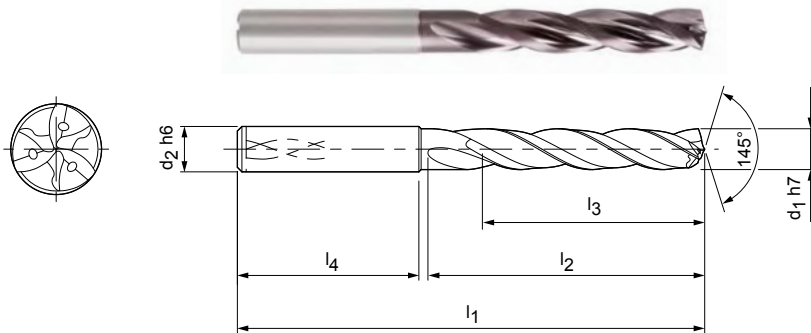

Serie selezionata per il magazzino con forma del codolo HA

Dimensioni						Forma del codolo HA	
d ₁ h7	d ₂ h6	l ₁	l ₂	l ₃	l ₄	Specifiche	Codice
4,00	6	74	36	29	36	SCD661-0400-3-3-145HA05-HP358	30902152
4,10	6	74	36	29	36	SCD661-0410-3-3-145HA05-HP358	30902153
4,20	6	74	36	29	36	SCD661-0420-3-3-145HA05-HP358	30902154
4,30	6	74	36	29	36	SCD661-0430-3-3-145HA05-HP358	30902155
4,40	6	74	36	29	36	SCD661-0440-3-3-145HA05-HP358	30902156
4,50	6	74	36	29	36	SCD661-0450-3-3-145HA05-HP358	30902157
4,60	6	74	36	29	36	SCD661-0460-3-3-145HA05-HP358	30902158
4,65	6	74	36	29	36	SCD661-0465-3-3-145HA05-HP358	30902159
4,70	6	74	36	29	36	SCD661-0470-3-3-145HA05-HP358	30902160
4,80	6	82	44	35	36	SCD661-0480-3-3-145HA05-HP358	30902161
4,90	6	82	44	35	36	SCD661-0490-3-3-145HA05-HP358	30902162
5,00	6	82	44	35	36	SCD661-0500-3-3-145HA05-HP358	30902163
5,10	6	82	44	35	36	SCD661-0510-3-3-145HA05-HP358	30902164
5,20	6	82	44	35	36	SCD661-0520-3-3-145HA05-HP358	30902165
5,30	6	82	44	35	36	SCD661-0530-3-3-145HA05-HP358	30902166
5,40	6	82	44	35	36	SCD661-0540-3-3-145HA05-HP358	30902167
5,50	6	82	44	35	36	SCD661-0550-3-3-145HA05-HP358	30902168
5,55	6	82	44	35	36	SCD661-0555-3-3-145HA05-HP358	30902169
5,60	6	82	44	35	36	SCD661-0560-3-3-145HA05-HP358	30902170
5,70	6	82	44	35	36	SCD661-0570-3-3-145HA05-HP358	30902171
5,80	6	82	44	35	36	SCD661-0580-3-3-145HA05-HP358	30902172
5,90	6	82	44	35	36	SCD661-0590-3-3-145HA05-HP358	30902173
6,00	6	82	44	35	36	SCD661-0600-3-3-145HA05-HP358	30902174
6,05	8	91	53	43	36	SCD661-0605-3-3-145HA05-HP358	31307526
6,10	8	91	53	43	36	SCD661-0610-3-3-145HA05-HP358	30902175
6,20	8	91	53	43	36	SCD661-0620-3-3-145HA05-HP358	30902176
6,30	8	91	53	43	36	SCD661-0630-3-3-145HA05-HP358	30902177
6,40	8	91	53	43	36	SCD661-0640-3-3-145HA05-HP358	30902178
6,50	8	91	53	43	36	SCD661-0650-3-3-145HA05-HP358	30902179
6,60	8	91	53	43	36	SCD661-0660-3-3-145HA05-HP358	30902180
6,80	8	91	53	43	36	SCD661-0680-3-3-145HA05-HP358	30902182
6,90	8	91	53	43	36	SCD661-0690-3-3-145HA05-HP358	30902183
7,00	8	91	53	43	36	SCD661-0700-3-3-145HA05-HP358	30902184
7,10	8	91	53	43	36	SCD661-0710-3-3-145HA05-HP358	30902185
7,20	8	91	53	43	36	SCD661-0720-3-3-145HA05-HP358	30902186

Tritan-Drill-Steel | Punta elicoidale in metallo duro integrale SCD661 (5xD), adduzione interna del refrigerante

Dimensioni						Forma del codolo HA	
d ₁ h7	d ₂ h6	l ₁	l ₂	l ₃	l ₄	Specifiche	Codice
7,30	8	91	53	43	36	SCD661-0730-3-3-145HA05-HP358	30902187
7,40	8	91	53	43	36	SCD661-0740-3-3-145HA05-HP358	30902188
7,45	8	91	53	43	36	SCD661-0745-3-3-145HA05-HP358	30902189
7,50	8	91	53	43	36	SCD661-0750-3-3-145HA05-HP358	30902190
7,60	8	91	53	43	36	SCD661-0760-3-3-145HA05-HP358	30902191
7,70	8	91	53	43	36	SCD661-0770-3-3-145HA05-HP358	30902192
7,80	8	91	53	43	36	SCD661-0780-3-3-145HA05-HP358	30902193
7,90	8	91	53	43	36	SCD661-0790-3-3-145HA05-HP358	30902194
8,00	8	91	53	43	36	SCD661-0800-3-3-145HA05-HP358	30902195
8,10	10	103	61	49	40	SCD661-0810-3-3-145HA05-HP358	30902196
8,20	10	103	61	49	40	SCD661-0820-3-3-145HA05-HP358	30902197
8,30	10	103	61	49	40	SCD661-0830-3-3-145HA05-HP358	30902198
8,40	10	103	61	49	40	SCD661-0840-3-3-145HA05-HP358	30902199
8,50	10	103	61	49	40	SCD661-0850-3-3-145HA05-HP358	30902200
8,60	10	103	61	49	40	SCD661-0860-3-3-145HA05-HP358	30902201
8,70	10	103	61	49	40	SCD661-0870-3-3-145HA05-HP358	30902202
8,80	10	103	61	49	40	SCD661-0880-3-3-145HA05-HP358	30902203
8,90	10	103	61	49	40	SCD661-0890-3-3-145HA05-HP358	30902204
9,00	10	103	61	49	40	SCD661-0900-3-3-145HA05-HP358	30902205
9,10	10	103	61	49	40	SCD661-0910-3-3-145HA05-HP358	30902206
9,20	10	103	61	49	40	SCD661-0920-3-3-145HA05-HP358	30902207
9,30	10	103	61	49	40	SCD661-0930-3-3-145HA05-HP358	30902208
9,35	10	103	61	49	40	SCD661-0935-3-3-145HA05-HP358	30902209
9,40	10	103	61	49	40	SCD661-0940-3-3-145HA05-HP358	30902210
9,50	10	103	61	49	40	SCD661-0950-3-3-145HA05-HP358	30902211
9,70	10	103	61	49	40	SCD661-0970-3-3-145HA05-HP358	30902214
9,80	10	103	61	49	40	SCD661-0980-3-3-145HA05-HP358	30902215
9,90	10	103	61	49	40	SCD661-0990-3-3-145HA05-HP358	30902216
10,00	10	103	61	49	40	SCD661-1000-3-3-145HA05-HP358	30902217
10,10	12	118	71	56	45	SCD661-1010-3-3-145HA05-HP358	30902218
10,20	12	118	71	56	45	SCD661-1020-3-3-145HA05-HP358	30902219
10,30	12	118	71	56	45	SCD661-1030-3-3-145HA05-HP358	30902220
10,40	12	118	71	56	45	SCD661-1040-3-3-145HA05-HP358	30902221
10,50	12	118	71	56	45	SCD661-1050-3-3-145HA05-HP358	30902222
10,80	12	118	71	56	45	SCD661-1080-3-3-145HA05-HP358	30902225
11,00	12	118	71	56	45	SCD661-1100-3-3-145HA05-HP358	30902227
11,10	12	118	71	56	45	SCD661-1110-3-3-145HA05-HP358	30902228
11,20	12	118	71	56	45	SCD661-1120-3-3-145HA05-HP358	30902229
11,30	12	118	71	56	45	SCD661-1130-3-3-145HA05-HP358	30902230
11,40	12	118	71	56	45	SCD661-1140-3-3-145HA05-HP358	30902231
11,50	12	118	71	56	45	SCD661-1150-3-3-145HA05-HP358	30902232
11,80	12	118	71	56	45	SCD661-1180-3-3-145HA05-HP358	30902235
11,90	12	118	71	56	45	SCD661-1190-3-3-145HA05-HP358	30902236
12,00	12	118	71	56	45	SCD661-1200-3-3-145HA05-HP358	30902237
12,20	14	124	77	60	45	SCD661-1220-3-3-145HA05-HP358	30902238
12,50	14	124	77	60	45	SCD661-1250-3-3-145HA05-HP358	30902239
12,80	14	124	77	60	45	SCD661-1280-3-3-145HA05-HP358	30902240
13,00	14	124	77	60	45	SCD661-1300-3-3-145HA05-HP358	30902241
13,50	14	124	77	60	45	SCD661-1350-3-3-145HA05-HP358	30902243
13,80	14	124	77	60	45	SCD661-1380-3-3-145HA05-HP358	30902244
14,00	14	124	77	60	45	SCD661-1400-3-3-145HA05-HP358	30902245
14,20	16	133	83	63	48	SCD661-1420-3-3-145HA05-HP358	30902246
14,50	16	133	83	63	48	SCD661-1450-3-3-145HA05-HP358	30902247
14,80	16	133	83	63	48	SCD661-1480-3-3-145HA05-HP358	30902248
15,00	16	133	83	63	48	SCD661-1500-3-3-145HA05-HP358	30902249
15,10	16	133	83	63	48	SCD661-1510-3-3-145HA05-HP358	30902250
15,20	16	133	83	63	48	SCD661-1520-3-3-145HA05-HP358	30902251

Tritan-Drill-Steel | Punta elicoidale in metallo duro integrale SCD661 (5xD), adduzione interna del refrigerante

Dimensioni						Forma del codolo HA	
d ₁ h7	d ₂ h6	l ₁	l ₂	l ₃	l ₄	Specifiche	Codice
15,25	16	133	83	63	48	SCD661-1525-3-3-145HA05-HP358	30902252
15,50	16	133	83	63	48	SCD661-1550-3-3-145HA05-HP358	30902253
15,80	16	133	83	63	48	SCD661-1580-3-3-145HA05-HP358	30902254
16,00	16	133	83	63	48	SCD661-1600-3-3-145HA05-HP358	30902255
16,20	18	143	93	71	48	SCD661-1620-3-3-145HA05-HP358	30902256
16,50	18	143	93	71	48	SCD661-1650-3-3-145HA05-HP358	30902257
16,80	18	143	93	71	48	SCD661-1680-3-3-145HA05-HP358	30902258
17,00	18	143	93	71	48	SCD661-1700-3-3-145HA05-HP358	30902259
17,50	18	143	93	71	48	SCD661-1750-3-3-145HA05-HP358	30902261
18,00	18	143	93	71	48	SCD661-1800-3-3-145HA05-HP358	30902263
18,50	20	153	101	77	50	SCD661-1850-3-3-145HA05-HP358	30902265
18,80	20	153	101	77	50	SCD661-1880-3-3-145HA05-HP358	30902266
19,00	20	153	101	77	50	SCD661-1900-3-3-145HA05-HP358	30902267
19,50	20	153	101	77	50	SCD661-1950-3-3-145HA05-HP358	30902269
19,80	20	153	101	77	50	SCD661-1980-3-3-145HA05-HP358	30902270
20,00	20	153	101	77	50	SCD661-2000-3-3-145HA05-HP358	30902271

Caratteristiche configurabili

**Diametro:**

Diametro a libera scelta a passi da 0,01 mm

**Forma del codolo:**

Forma del codolo: HB | HE

Specifiche:

SCD661-[diametro]-3-3-145[forma del codolo]05-HP358

Dimensioni serie configurabile

d ₁ min.	d ₁ max.	d ₂ h6	l ₁	l ₂	l ₃	l ₄
4,00	4,70	6	74	36	29	36
4,71	6,00	6	82	44	35	36
6,01	8,00	8	91	53	43	36
8,01	10,00	10	103	61	49	40
10,01	12,00	12	118	71	56	45
12,01	14,00	14	124	77	60	45
14,01	16,00	16	133	83	63	48
16,01	18,00	18	143	93	71	48
18,01	20,00	20	153	101	77	50

Esempio:

SCD661-0431-3-3-145HE05-HP358

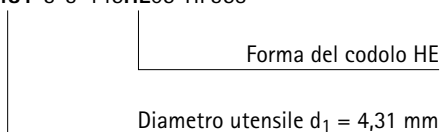

Misure in mm.

Per i parametri di lavorazione consigliati, vedere la fine del capitolo.

Versioni speciali e altri rivestimenti disponibili su richiesta.

Tritan-Drill-Steel

Punta elicoidale in metallo duro integrale
SCD661 (8xD), adduzione interna del refrigerante

Versione:

Diametro punta: 4,00 – 20,00 mm
Tolleranza di foratura: \geq IT 9
Materiale da taglio: HP358
Numero di taglienti: 3
Numero margini di guida: 3
Angolo tra taglienti: 140°
Angolo dell'elica: 30°

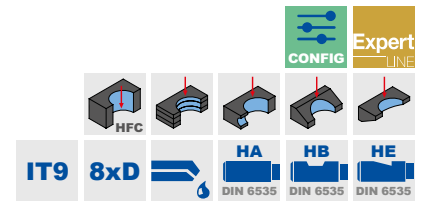
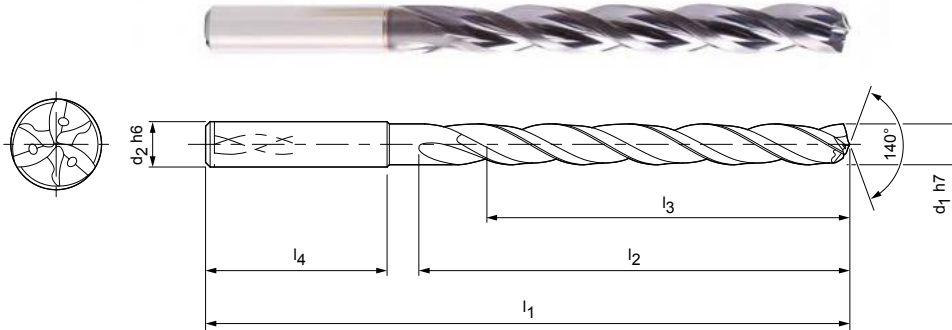

Serie selezionata per il magazzino con forma del codolo HA

Dimensioni						Forma del codolo HA	
d ₁ h7	d ₂ h6	l ₁	l ₂	l ₃	l ₄	Specifiche	Codice
4,00	6	81	43	36	36	SCD661-0400-3-3-140HA08-HP358	30902272
4,10	6	81	43	36	36	SCD661-0410-3-3-140HA08-HP358	30902273
4,20	6	81	43	36	36	SCD661-0420-3-3-140HA08-HP358	30902274
4,30	6	81	43	36	36	SCD661-0430-3-3-140HA08-HP358	30902275
4,50	6	81	43	36	36	SCD661-0450-3-3-140HA08-HP358	30902277
4,60	6	81	43	36	36	SCD661-0460-3-3-140HA08-HP358	30902278
4,70	6	81	43	36	36	SCD661-0470-3-3-140HA08-HP358	30902279
4,80	6	95	57	48	36	SCD661-0480-3-3-140HA08-HP358	30902280
5,00	6	95	57	48	36	SCD661-0500-3-3-140HA08-HP358	30902282
5,10	6	95	57	48	36	SCD661-0510-3-3-140HA08-HP358	30902283
5,20	6	95	57	48	36	SCD661-0520-3-3-140HA08-HP358	30902284
5,40	6	95	57	48	36	SCD661-0540-3-3-140HA08-HP358	30902286
5,50	6	95	57	48	36	SCD661-0550-3-3-140HA08-HP358	30902287
5,60	6	95	57	48	36	SCD661-0560-3-3-140HA08-HP358	30902288
5,80	6	95	57	48	36	SCD661-0580-3-3-140HA08-HP358	30902290
5,90	6	95	57	48	36	SCD661-0590-3-3-140HA08-HP358	30902291
6,00	6	95	57	48	36	SCD661-0600-3-3-140HA08-HP358	30902292
6,10	8	114	76	64	36	SCD661-0610-3-3-140HA08-HP358	30902293
6,50	8	114	76	64	36	SCD661-0650-3-3-140HA08-HP358	30902297
6,60	8	114	76	64	36	SCD661-0660-3-3-140HA08-HP358	30902298
6,80	8	114	76	64	36	SCD661-0680-3-3-140HA08-HP358	30902300
6,90	8	114	76	64	36	SCD661-0690-3-3-140HA08-HP358	30902301
7,00	8	114	76	64	36	SCD661-0700-3-3-140HA08-HP358	30902302
7,50	8	114	76	64	36	SCD661-0750-3-3-140HA08-HP358	30902307
7,80	8	114	76	64	36	SCD661-0780-3-3-140HA08-HP358	30902310
7,90	8	114	76	64	36	SCD661-0790-3-3-140HA08-HP358	30902311
8,00	8	114	76	64	36	SCD661-0800-3-3-140HA08-HP358	30902312
8,10	10	142	95	80	40	SCD661-0810-3-3-140HA08-HP358	30902313
8,20	10	142	95	80	40	SCD661-0820-3-3-140HA08-HP358	30902314
8,50	10	142	95	80	40	SCD661-0850-3-3-140HA08-HP358	30902317
8,60	10	142	95	80	40	SCD661-0860-3-3-140HA08-HP358	30902318
8,80	10	142	95	80	40	SCD661-0880-3-3-140HA08-HP358	30902320
9,00	10	142	95	80	40	SCD661-0900-3-3-140HA08-HP358	30902322
9,10	10	142	95	80	40	SCD661-0910-3-3-140HA08-HP358	30902323
9,50	10	142	95	80	40	SCD661-0950-3-3-140HA08-HP358	30902327

Tritan-Drill-Steel | Punta elicoidale in metallo duro integrale SCD661 (8xD), adduzione interna del refrigerante

Dimensioni						Forma del codolo HA	
d ₁ h7	d ₂ h6	l ₁	l ₂	l ₃	l ₄	Specifiche	Codice
9,80	10	142	95	80	40	SCD661-0980-3-3-140HA08-HP358	30902330
10,00	10	142	95	80	40	SCD661-1000-3-3-140HA08-HP358	30902332
10,20	12	162	114	96	45	SCD661-1020-3-3-140HA08-HP358	30902334
10,30	12	162	114	96	45	SCD661-1030-3-3-140HA08-HP358	30902335
10,50	12	162	114	96	45	SCD661-1050-3-3-140HA08-HP358	30902337
11,00	12	162	114	96	45	SCD661-1100-3-3-140HA08-HP358	30902342
11,50	12	162	114	96	45	SCD661-1150-3-3-140HA08-HP358	30902347
11,80	12	162	114	96	45	SCD661-1180-3-3-140HA08-HP358	30902350
11,90	12	162	114	96	45	SCD661-1190-3-3-140HA08-HP358	30902351
12,00	12	162	114	96	45	SCD661-1200-3-3-140HA08-HP358	30902352
12,20	14	178	133	112	45	SCD661-1220-3-3-140HA08-HP358	30902353
12,50	14	178	133	112	45	SCD661-1250-3-3-140HA08-HP358	30902354
13,00	14	178	133	112	45	SCD661-1300-3-3-140HA08-HP358	30902356
13,50	14	178	133	112	45	SCD661-1350-3-3-140HA08-HP358	30902358
13,80	14	178	133	112	45	SCD661-1380-3-3-140HA08-HP358	30902359
14,00	14	178	133	112	45	SCD661-1400-3-3-140HA08-HP358	30902360
14,20	16	203	152	128	48	SCD661-1420-3-3-140HA08-HP358	30902361
14,50	16	203	152	128	48	SCD661-1450-3-3-140HA08-HP358	30902362
15,00	16	203	152	128	48	SCD661-1500-3-3-140HA08-HP358	30902364
15,50	16	203	152	128	48	SCD661-1550-3-3-140HA08-HP358	30902366
15,80	16	203	152	128	48	SCD661-1580-3-3-140HA08-HP358	30902367
16,00	16	203	152	128	48	SCD661-1600-3-3-140HA08-HP358	30902368
17,00	18	222	171	144	48	SCD661-1700-3-3-140HA08-HP358	30902372
17,50	18	222	171	144	48	SCD661-1750-3-3-140HA08-HP358	30902374
18,00	18	222	171	144	48	SCD661-1800-3-3-140HA08-HP358	30902376
18,50	20	243	190	160	50	SCD661-1850-3-3-140HA08-HP358	30902378
19,00	20	243	190	160	50	SCD661-1900-3-3-140HA08-HP358	30902380
19,20	20	243	190	160	50	SCD661-1920-3-3-140HA08-HP358	30902381
19,50	20	243	190	160	50	SCD661-1950-3-3-140HA08-HP358	30902382
20,00	20	243	190	160	50	SCD661-2000-3-3-140HA08-HP358	30902384

Caratteristiche configurabili

**Diametro:**

Diametro a libera scelta a passi da 0,01 mm

**Forma del codolo:**

Forma del codolo: HB | HE

Specifiche:

SCD661-[diametro]-3-3-140[forma del codolo]08-HP358

Dimensioni serie configurabile

d ₁ min.	d ₁ max.	d ₂ h6	l ₁	l ₂	l ₃	l ₄
4,00	4,70	6	81	43	36	36
4,71	6,00	6	95	57	48	36
6,01	8,00	8	114	76	64	36
8,01	10,00	10	142	95	80	40
10,01	12,00	12	162	114	96	45
12,01	14,00	14	178	133	112	45
14,01	16,00	16	203	152	128	48
16,01	18,00	18	222	171	144	48
18,01	20,00	20	243	190	160	50

Esempio:

SCD661-0431-3-3-140HE08-HP358

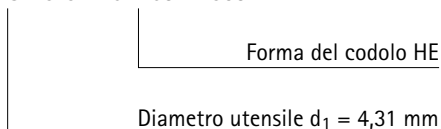

Misure in mm.

Per i parametri di lavorazione consigliati, vedere la fine del capitolo.

Versioni speciali e altri rivestimenti disponibili su richiesta.

Tritan-Drill-Steel

Punta elicoidale in metallo duro integrale
SCD661 (12xD), adduzione interna del refrigerante

Versione:

Diametro punta: 4,00 – 20,00 mm
Tolleranza di foratura: \geq IT 9
Materiale da taglio: HP358
Numero di taglienti: 3
Numero margini di guida: 3
Angolo tra taglienti: 140°
Angolo dell'elica: 30°

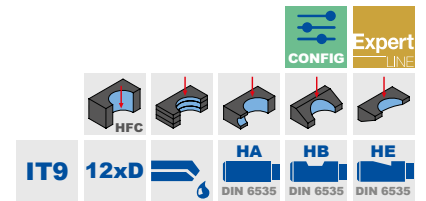
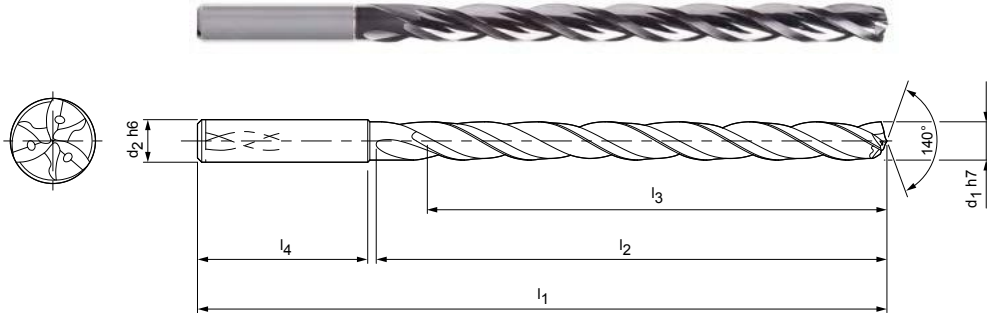

Serie selezionata per il magazzino con forma del codolo HA

Dimensioni						Forma del codolo HA	
d_1 h7	d_2 h6	l_1	l_2	l_3	l_4	Specifiche	Codice
4,00	6	102	64	58	36	SCD661-0400-3-3-140HA12-HP358	30902385
4,10	6	102	64	58	36	SCD661-0410-3-3-140HA12-HP358	30902386
4,20	6	102	64	58	36	SCD661-0420-3-3-140HA12-HP358	30902387
4,30	6	102	64	58	36	SCD661-0430-3-3-140HA12-HP358	30902388
4,50	6	102	64	58	36	SCD661-0450-3-3-140HA12-HP358	30902390
4,60	6	102	64	58	36	SCD661-0460-3-3-140HA12-HP358	30902391
4,80	6	116	78	70	36	SCD661-0480-3-3-140HA12-HP358	30902393
5,00	6	116	78	70	36	SCD661-0500-3-3-140HA12-HP358	30902395
5,10	6	116	78	70	36	SCD661-0510-3-3-140HA12-HP358	30902396
5,20	6	116	78	70	36	SCD661-0520-3-3-140HA12-HP358	30902397
5,40	6	116	78	70	36	SCD661-0540-3-3-140HA12-HP358	30902399
5,50	6	116	78	70	36	SCD661-0550-3-3-140HA12-HP358	30902400
5,80	6	116	78	70	36	SCD661-0580-3-3-140HA12-HP358	30902403
5,90	6	116	78	70	36	SCD661-0590-3-3-140HA12-HP358	30902404
6,00	6	116	78	70	36	SCD661-0600-3-3-140HA12-HP358	30902405
6,10	8	146	108	94	36	SCD661-0610-3-3-140HA12-HP358	30902406
6,50	8	146	108	94	36	SCD661-0650-3-3-140HA12-HP358	30902410
6,80	8	146	108	94	36	SCD661-0680-3-3-140HA12-HP358	30902413
7,00	8	146	108	94	36	SCD661-0700-3-3-140HA12-HP358	30902415
7,50	8	146	108	94	36	SCD661-0750-3-3-140HA12-HP358	30902420
7,80	8	146	108	94	36	SCD661-0780-3-3-140HA12-HP358	30902423
7,90	8	146	108	94	36	SCD661-0790-3-3-140HA12-HP358	30902424
8,00	8	146	108	94	36	SCD661-0800-3-3-140HA12-HP358	30902425
8,20	10	162	120	110	40	SCD661-0820-3-3-140HA12-HP358	30902427
8,40	10	162	120	110	40	SCD661-0840-3-3-140HA12-HP358	30902429
8,50	10	162	120	110	40	SCD661-0850-3-3-140HA12-HP358	30902430
8,80	10	162	120	110	40	SCD661-0880-3-3-140HA12-HP358	30902433
9,00	10	162	120	110	40	SCD661-0900-3-3-140HA12-HP358	30902435
9,50	10	162	120	110	40	SCD661-0950-3-3-140HA12-HP358	30902440
9,60	10	162	120	110	40	SCD661-0960-3-3-140HA12-HP358	30902441
9,80	10	162	120	110	40	SCD661-0980-3-3-140HA12-HP358	30902443
10,00	10	162	120	110	40	SCD661-1000-3-3-140HA12-HP358	30902445
10,20	12	204	156	142	45	SCD661-1020-3-3-140HA12-HP358	30902447
10,30	12	204	156	142	45	SCD661-1030-3-3-140HA12-HP358	30902448
10,50	12	204	156	142	45	SCD661-1050-3-3-140HA12-HP358	30902450

Tritan-Drill-Steel | Punta elicoidale in metallo duro integrale SCD661 (12xD), adduzione interna del refrigerante

Dimensioni						Forma del codolo HA	
d ₁ h7	d ₂ h6	l ₁	l ₂	l ₃	l ₄	Specifiche	Codice
11,00	12	204	156	142	45	SCD661-1100-3-3-140HA12-HP358	30902455
11,50	12	204	156	142	45	SCD661-1150-3-3-140HA12-HP358	30902460
11,80	12	204	156	142	45	SCD661-1180-3-3-140HA12-HP358	30902463
12,00	12	204	156	142	45	SCD661-1200-3-3-140HA12-HP358	30902465
12,50	14	230	182	166	45	SCD661-1250-3-3-140HA12-HP358	30902467
13,00	14	230	182	166	45	SCD661-1300-3-3-140HA12-HP358	30902469
13,50	14	230	182	166	45	SCD661-1350-3-3-140HA12-HP358	30902471
14,00	14	230	182	166	45	SCD661-1400-3-3-140HA12-HP358	30902473
14,50	16	260	208	192	48	SCD661-1450-3-3-140HA12-HP358	30902475
15,00	16	260	208	192	48	SCD661-1500-3-3-140HA12-HP358	30902477
15,50	16	260	208	192	48	SCD661-1550-3-3-140HA12-HP358	30902479
16,00	16	260	208	192	48	SCD661-1600-3-3-140HA12-HP358	30902481
16,50	18	285	234	216	48	SCD661-1650-3-3-140HA12-HP358	30902483
17,00	18	285	234	216	48	SCD661-1700-3-3-140HA12-HP358	30902485
17,50	18	285	234	216	48	SCD661-1750-3-3-140HA12-HP358	30902487
18,00	18	285	234	216	48	SCD661-1800-3-3-140HA12-HP358	30902489
18,50	20	310	258	240	50	SCD661-1850-3-3-140HA12-HP358	30902491
19,00	20	310	258	240	50	SCD661-1900-3-3-140HA12-HP358	30902493
19,50	20	310	258	240	50	SCD661-1950-3-3-140HA12-HP358	30902495
20,00	20	310	258	240	50	SCD661-2000-3-3-140HA12-HP358	30902497

Caratteristiche configurabili

**Diametro:**

Diametro a libera scelta a passi da 0,01 mm

**Forma del codolo:**

Forma del codolo: HB | HE

Specifiche:

SCD661-[diametro]-3-3-140[forma del codolo]12-HP358

Dimensioni serie configurabile

d ₁ min.	d ₁ max.	d ₂ h6	l ₁	l ₂	l ₃	l ₄
4,00	4,70	6	102	64	58	36
4,71	6,00	6	116	78	70	36
6,01	8,00	8	146	108	94	36
8,01	10,00	10	162	120	110	40
10,01	12,00	12	204	156	142	45
12,01	14,00	14	230	182	166	45
14,01	16,00	16	260	208	192	48
16,01	18,00	18	285	234	216	48
18,01	20,00	20	310	258	240	50

Esempio:

SCD661-0431-3-3-140HE12-HP358

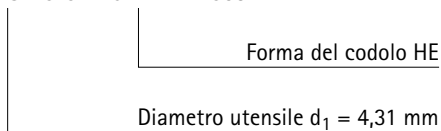

Misure in mm.

Per i parametri di lavorazione consigliati, vedere la fine del capitolo.

Versioni speciali e altri rivestimenti disponibili su richiesta.

MEGA-Speed-Drill-Steel

Punta elicoidale in metallo duro integrale

SCD621 (3xD), adduzione interna del refrigerante, prodotto successivo a MEGA-Speed-Drill-Steel (SCD22)

Versione:

Diametro punta: 3,00 – 20,00 mm
 Tolleranza di foratura: IT 9 (raggiungibile)
 Materiale da taglio: HP358
 Numero di taglienti: 2
 Numero margini di guida: 3
 Angolo tra taglienti: 145°
 Angolo dell'elica: 30°

Applicazione:

Per lavorazioni ad alta velocità.

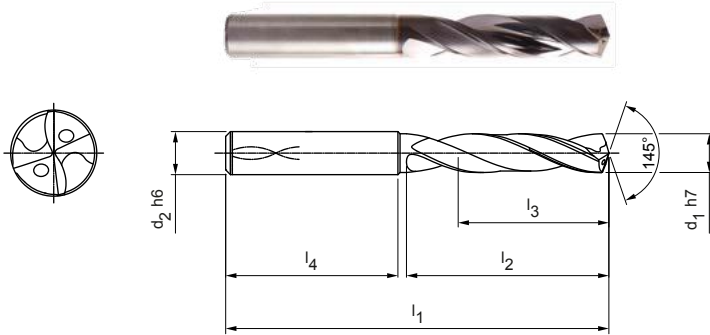

Serie selezionata per il magazzino con forma del codolo HA

Dimensioni						Forma del codolo HA	
d ₁ h7	d ₂ h6	l ₁	l ₂	l ₃	l ₄	Specifiche	Codice
3,00	6	62	20	14	36	SCD621-0300-2-3-145HA03-HP358	31036265
3,20	6	62	20	14	36	SCD621-0320-2-3-145HA03-HP358	31036267
3,30	6	62	20	14	36	SCD621-0330-2-3-145HA03-HP358	31036268
3,40	6	62	20	14	36	SCD621-0340-2-3-145HA03-HP358	31036269
3,50	6	62	20	14	36	SCD621-0350-2-3-145HA03-HP358	31036270
3,70	6	62	20	14	36	SCD621-0370-2-3-145HA03-HP358	31036272
3,80	6	66	24	17	36	SCD621-0380-2-3-145HA03-HP358	31036273
3,90	6	66	24	17	36	SCD621-0390-2-3-145HA03-HP358	31036274
4,00	6	66	24	17	36	SCD621-0400-2-3-145HA03-HP358	31036275
4,10	6	66	24	17	36	SCD621-0410-2-3-145HA03-HP358	31036276
4,20	6	66	24	17	36	SCD621-0420-2-3-145HA03-HP358	31036277
4,30	6	66	24	17	36	SCD621-0430-2-3-145HA03-HP358	31036278
4,50	6	66	24	17	36	SCD621-0450-2-3-145HA03-HP358	31036280
4,60	6	66	24	17	36	SCD621-0460-2-3-145HA03-HP358	31036281
4,65	6	66	24	17	36	SCD621-0465-2-3-145HA03-HP358	31307528
4,70	6	66	24	17	36	SCD621-0470-2-3-145HA03-HP358	31036282
4,90	6	66	28	20	36	SCD621-0490-2-3-145HA03-HP358	31036284
5,00	6	66	28	20	36	SCD621-0500-2-3-145HA03-HP358	31036285
5,10	6	66	28	20	36	SCD621-0510-2-3-145HA03-HP358	31036286
5,20	6	66	28	20	36	SCD621-0520-2-3-145HA03-HP358	31036287
5,50	6	66	28	20	36	SCD621-0550-2-3-145HA03-HP358	31036290
5,60	6	66	28	20	36	SCD621-0560-2-3-145HA03-HP358	31036291
5,80	6	66	28	20	36	SCD621-0580-2-3-145HA03-HP358	31036293
5,90	6	66	28	20	36	SCD621-0590-2-3-145HA03-HP358	31036294
6,00	6	66	28	20	36	SCD621-0600-2-3-145HA03-HP358	31036295
6,10	8	79	34	24	36	SCD621-0610-2-3-145HA03-HP358	31036296
6,20	8	79	34	24	36	SCD621-0620-2-3-145HA03-HP358	31036297
6,30	8	79	34	24	36	SCD621-0630-2-3-145HA03-HP358	31036298
6,40	8	79	34	24	36	SCD621-0640-2-3-145HA03-HP358	31036299
6,50	8	79	34	24	36	SCD621-0650-2-3-145HA03-HP358	31036300
6,60	8	79	34	24	36	SCD621-0660-2-3-145HA03-HP358	31036301
6,80	8	79	34	24	36	SCD621-0680-2-3-145HA03-HP358	31036303
6,90	8	79	34	24	36	SCD621-0690-2-3-145HA03-HP358	31036304
7,00	8	79	34	24	36	SCD621-0700-2-3-145HA03-HP358	31036305
7,15	8	79	41	29	36	SCD621-0715-2-3-145HA03-HP358	31307529

MEGA-Speed-Drill-Steel | Punta elicoidale in metallo duro integrale SCD621 (3xD), adduzione interna del refrigerante

Dimensioni						Forma del codolo HA	
d ₁ h ₇	d ₂ h ₆	l ₁	l ₂	l ₃	l ₄	Specifiche	Codice
7,30	8	79	41	29	36	SCD621-0730-2-3-145HA03-HP358	31036308
7,40	8	79	41	29	36	SCD621-0740-2-3-145HA03-HP358	31036309
7,50	8	79	41	29	36	SCD621-0750-2-3-145HA03-HP358	31036310
7,60	8	79	41	29	36	SCD621-0760-2-3-145HA03-HP358	31036311
7,70	8	79	41	29	36	SCD621-0770-2-3-145HA03-HP358	31036312
7,80	8	79	41	29	36	SCD621-0780-2-3-145HA03-HP358	31036313
8,00	8	79	41	29	36	SCD621-0800-2-3-145HA03-HP358	31036315
8,20	10	89	47	35	40	SCD621-0820-2-3-145HA03-HP358	31036317
8,50	10	89	47	35	40	SCD621-0850-2-3-145HA03-HP358	31036320
8,60	10	89	47	35	40	SCD621-0860-2-3-145HA03-HP358	31036321
8,70	10	89	47	35	40	SCD621-0870-2-3-145HA03-HP358	31036322
8,80	10	89	47	35	40	SCD621-0880-2-3-145HA03-HP358	31036323
8,90	10	89	47	35	40	SCD621-0890-2-3-145HA03-HP358	31036324
9,00	10	89	47	35	40	SCD621-0900-2-3-145HA03-HP358	31036325
9,10	10	89	47	35	40	SCD621-0910-2-3-145HA03-HP358	31036326
9,20	10	89	47	35	40	SCD621-0920-2-3-145HA03-HP358	31036327
9,30	10	89	47	35	40	SCD621-0930-2-3-145HA03-HP358	31036328
9,40	10	89	47	35	40	SCD621-0940-2-3-145HA03-HP358	31036329
9,50	10	89	47	35	40	SCD621-0950-2-3-145HA03-HP358	31036330
9,60	10	89	47	35	40	SCD621-0960-2-3-145HA03-HP358	31036331
9,80	10	89	47	35	40	SCD621-0980-2-3-145HA03-HP358	31036333
9,90	10	89	47	35	40	SCD621-0990-2-3-145HA03-HP358	31036334
10,00	10	89	47	35	40	SCD621-1000-2-3-145HA03-HP358	31036335
10,20	12	102	55	40	45	SCD621-1020-2-3-145HA03-HP358	31036337
10,30	12	102	55	40	45	SCD621-1030-2-3-145HA03-HP358	31036338
10,50	12	102	55	40	45	SCD621-1050-2-3-145HA03-HP358	31036340
11,00	12	102	55	40	45	SCD621-1100-2-3-145HA03-HP358	31036345
11,20	12	102	55	40	45	SCD621-1120-2-3-145HA03-HP358	31036347
11,50	12	102	55	40	45	SCD621-1150-2-3-145HA03-HP358	31036350
11,80	12	102	55	40	45	SCD621-1180-2-3-145HA03-HP358	31036353
11,90	12	102	55	40	45	SCD621-1190-2-3-145HA03-HP358	31036354
12,00	12	102	55	40	45	SCD621-1200-2-3-145HA03-HP358	31036355
13,00	14	107	60	43	45	SCD621-1300-2-3-145HA03-HP358	31036359
13,80	14	107	60	43	45	SCD621-1380-2-3-145HA03-HP358	31036361
14,00	14	107	60	43	45	SCD621-1400-2-3-145HA03-HP358	31036362
14,50	16	115	65	45	48	SCD621-1450-2-3-145HA03-HP358	31036364
15,00	16	115	65	45	48	SCD621-1500-2-3-145HA03-HP358	31036366
16,00	16	115	65	45	48	SCD621-1600-2-3-145HA03-HP358	31036370
17,00	18	123	73	51	48	SCD621-1700-2-3-145HA03-HP358	31036373
17,50	18	123	73	51	48	SCD621-1750-2-3-145HA03-HP358	31036374
18,00	18	123	73	51	48	SCD621-1800-2-3-145HA03-HP358	31036376
18,50	20	131	79	55	50	SCD621-1850-2-3-145HA03-HP358	31036377
20,00	20	131	79	55	50	SCD621-2000-2-3-145HA03-HP358	31036392

MEGA-Speed-Drill-Steel | Punta elicoidale in metallo duro integrale SCD621 (3xD), adduzione interna del refrigerante

Caratteristiche configurabili

**Diametro:**

Diametro a libera scelta a passi da 0,01 mm

**Forma del codolo:**

Forma del codolo HB | HE

Specifiche:

SCD621-[diametro]-2-3-145[forma del codolo]03-HP358

Dimensioni serie configurabile

d ₁ min.	d ₁ max.	d ₂ h6	l ₁	l ₂	l ₃	l ₄
3,00	3,70	6	62	20	14	36
3,71	4,70	6	66	24	17	36
4,71	6,00	6	66	28	20	36
6,01	6,80	8	79	34	24	36
6,81	8,00	8	79	41	29	36
8,01	10,00	10	89	47	35	40
10,01	12,00	12	102	55	40	45
12,01	14,00	14	107	60	43	45
14,01	16,00	16	115	65	45	48
16,01	18,00	18	123	73	51	48
18,01	20,00	20	131	79	55	50

Esempio:

SCD621-0431-2-3-145HE03-HP358

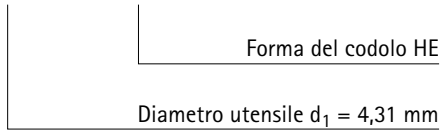

Misure in mm.

Per i parametri di lavorazione consigliati, vedere la fine del capitolo.

Versioni speciali e altri rivestimenti disponibili su richiesta.

MEGA-Speed-Drill-Steel

Punta elicoidale in metallo duro integrale

SCD621 (5xD), adduzione interna del refrigerante, prodotto successivo a MEGA-Speed-Drill-Steel (SCD22)

Versione:

- Diametro punta: 3,00 – 20,00 mm
- Tolleranza di foratura: \geq IT 9
- Materiale da taglio: HP358
- Numero di taglienti: 2
- Numero margini di guida: 3
- Angolo tra taglienti: 145°
- Angolo dell'elica: 30°

Applicazione:

Per lavorazioni ad alta velocità.

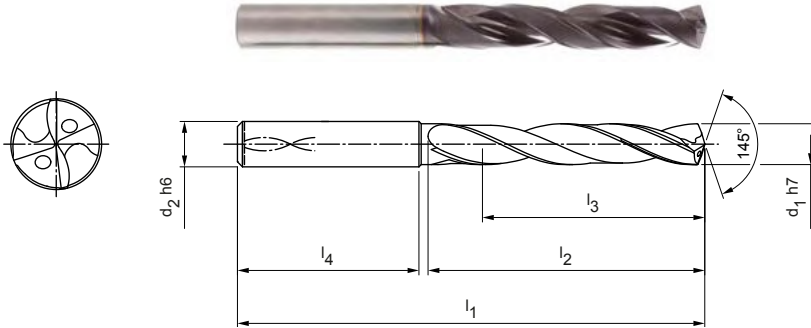

Serie selezionata per il magazzino con forma del codolo HA

Dimensioni						Forma del codolo HA	
d ₁ h7	d ₂ h6	l ₁	l ₂	l ₃	l ₄	Specifiche	Codice
3,00	6	66	28	23	36	SCD621-0300-2-3-145HA05-HP358	30966287
3,10	6	66	28	23	36	SCD621-0310-2-3-145HA05-HP358	30966288
3,20	6	66	28	23	36	SCD621-0320-2-3-145HA05-HP358	30966289
3,30	6	66	28	23	36	SCD621-0330-2-3-145HA05-HP358	30966310
3,40	6	66	28	23	36	SCD621-0340-2-3-145HA05-HP358	30966311
3,50	6	66	28	23	36	SCD621-0350-2-3-145HA05-HP358	30959126
3,70	6	66	28	23	36	SCD621-0370-2-3-145HA05-HP358	30966313
3,80	6	74	36	29	36	SCD621-0380-2-3-145HA05-HP358	30966314
4,00	6	74	36	29	36	SCD621-0400-2-3-145HA05-HP358	30966316
4,20	6	74	36	29	36	SCD621-0420-2-3-145HA05-HP358	30966318
4,30	6	74	36	29	36	SCD621-0430-2-3-145HA05-HP358	30966319
4,50	6	74	36	29	36	SCD621-0450-2-3-145HA05-HP358	30966321
4,65	6	74	36	29	36	SCD621-0465-2-3-145HA05-HP358	31307540
4,70	6	74	36	29	36	SCD621-0470-2-3-145HA05-HP358	30966323
4,80	6	82	44	35	36	SCD621-0480-2-3-145HA05-HP358	30966324
4,90	6	82	44	35	36	SCD621-0490-2-3-145HA05-HP358	30966326
5,00	6	82	44	35	36	SCD621-0500-2-3-145HA05-HP358	30966327
5,10	6	82	44	35	36	SCD621-0510-2-3-145HA05-HP358	30966328
5,20	6	82	44	35	36	SCD621-0520-2-3-145HA05-HP358	30966329
5,30	6	82	44	35	36	SCD621-0530-2-3-145HA05-HP358	30966330
5,40	6	82	44	35	36	SCD621-0540-2-3-145HA05-HP358	30966331
5,50	6	82	44	35	36	SCD621-0550-2-3-145HA05-HP358	30966332
5,55	6	82	44	35	36	SCD621-0555-2-3-145HA05-HP358	31307541
5,60	6	82	44	35	36	SCD621-0560-2-3-145HA05-HP358	30966333
5,70	6	82	44	35	36	SCD621-0570-2-3-145HA05-HP358	30966334
5,80	6	82	44	35	36	SCD621-0580-2-3-145HA05-HP358	30966335
5,90	6	82	44	35	36	SCD621-0590-2-3-145HA05-HP358	30966336
6,00	6	82	44	35	36	SCD621-0600-2-3-145HA05-HP358	30966337
6,10	8	91	53	43	36	SCD621-0610-2-3-145HA05-HP358	30966338
6,20	8	91	53	43	36	SCD621-0620-2-3-145HA05-HP358	30966339
6,30	8	91	53	43	36	SCD621-0630-2-3-145HA05-HP358	30966340
6,50	8	91	53	43	36	SCD621-0650-2-3-145HA05-HP358	30966342
6,70	8	91	53	43	36	SCD621-0670-2-3-145HA05-HP358	30966344
6,80	8	91	53	43	36	SCD621-0680-2-3-145HA05-HP358	30966345

MEGA-Speed-Drill-Steel | Punta elicoidale in metallo duro integrale SCD621 (5xD), adduzione interna del refrigerante

Dimensioni						Forma del codolo HA	
d ₁ h7	d ₂ h6	l ₁	l ₂	l ₃	l ₄	Specifiche	Codice
6,90	8	91	53	43	36	SCD621-0690-2-3-145HA05-HP358	30966346
7,00	8	91	53	43	36	SCD621-0700-2-3-145HA05-HP358	30966347
7,10	8	91	53	43	36	SCD621-0710-2-3-145HA05-HP358	30966348
7,20	8	91	53	43	36	SCD621-0720-2-3-145HA05-HP358	30966349
7,30	8	91	53	43	36	SCD621-0730-2-3-145HA05-HP358	30966350
7,40	8	91	53	43	36	SCD621-0740-2-3-145HA05-HP358	30966351
7,50	8	91	53	43	36	SCD621-0750-2-3-145HA05-HP358	30966352
7,60	8	91	53	43	36	SCD621-0760-2-3-145HA05-HP358	30966353
7,80	8	91	53	43	36	SCD621-0780-2-3-145HA05-HP358	30966355
8,00	8	91	53	43	36	SCD621-0800-2-3-145HA05-HP358	30948674
8,10	10	103	61	49	40	SCD621-0810-2-3-145HA05-HP358	30966357
8,20	10	103	61	49	40	SCD621-0820-2-3-145HA05-HP358	30966358
8,30	10	103	61	49	40	SCD621-0830-2-3-145HA05-HP358	30966359
8,40	10	103	61	49	40	SCD621-0840-2-3-145HA05-HP358	30966360
8,50	10	103	61	49	40	SCD621-0850-2-3-145HA05-HP358	30959302
8,60	10	103	61	49	40	SCD621-0860-2-3-145HA05-HP358	30966361
8,70	10	89	47	35	40	SCD621-0870-2-3-145HA05-HP358	30812607
8,80	10	103	61	49	40	SCD621-0880-2-3-145HA05-HP358	30966362
9,00	10	103	61	49	40	SCD621-0900-2-3-145HA05-HP358	30966364
9,10	10	103	61	49	40	SCD621-0910-2-3-145HA05-HP358	30966365
9,30	10	103	61	49	40	SCD621-0930-2-3-145HA05-HP358	30966367
9,40	10	103	61	49	40	SCD621-0940-2-3-145HA05-HP358	30966368
9,50	10	103	61	49	40	SCD621-0950-2-3-145HA05-HP358	30966369
9,70	10	103	61	49	40	SCD621-0970-2-3-145HA05-HP358	30958145
9,80	10	103	61	49	40	SCD621-0980-2-3-145HA05-HP358	30959402
9,90	10	103	61	49	40	SCD621-0990-2-3-145HA05-HP358	30966371
10,00	10	103	61	49	40	SCD621-1000-2-3-145HA05-HP358	30948675
10,20	12	118	71	56	45	SCD621-1020-2-3-145HA05-HP358	30966373
10,30	12	118	71	56	45	SCD621-1030-2-3-145HA05-HP358	30966374
10,50	12	118	71	56	45	SCD621-1050-2-3-145HA05-HP358	30966376
11,00	12	118	71	56	45	SCD621-1100-2-3-145HA05-HP358	30966381
11,10	12	118	71	56	45	SCD621-1110-2-3-145HA05-HP358	30966382
11,20	12	118	71	56	45	SCD621-1120-2-3-145HA05-HP358	30966383
11,30	12	118	71	56	45	SCD621-1130-2-3-145HA05-HP358	30966384
11,40	12	118	71	56	45	SCD621-1140-2-3-145HA05-HP358	30966385
11,50	12	118	71	56	45	SCD621-1150-2-3-145HA05-HP358	30966386
11,60	12	118	71	56	45	SCD621-1160-2-3-145HA05-HP358	30966387
11,80	12	118	71	56	45	SCD621-1180-2-3-145HA05-HP358	30966389
11,90	12	118	71	56	45	SCD621-1190-2-3-145HA05-HP358	30966390
12,00	12	118	71	56	45	SCD621-1200-2-3-145HA05-HP358	30948676
12,20	14	124	77	60	45	SCD621-1220-2-3-145HA05-HP358	30966391
12,50	14	124	77	60	45	SCD621-1250-2-3-145HA05-HP358	30966392
12,80	14	124	77	60	45	SCD621-1280-2-3-145HA05-HP358	30980599
13,00	14	124	77	60	45	SCD621-1300-2-3-145HA05-HP358	30966393
13,50	14	124	77	60	45	SCD621-1350-2-3-145HA05-HP358	30966394
13,80	14	124	77	60	45	SCD621-1380-2-3-145HA05-HP358	30966395
14,00	14	124	77	60	45	SCD621-1400-2-3-145HA05-HP358	30966396
14,20	16	133	83	63	48	SCD621-1420-2-3-145HA05-HP358	30966397
14,50	16	133	83	63	48	SCD621-1450-2-3-145HA05-HP358	30966398
15,00	16	133	83	63	48	SCD621-1500-2-3-145HA05-HP358	30966400
15,20	16	133	83	63	48	SCD621-1520-2-3-145HA05-HP358	30966401
15,50	16	133	83	63	48	SCD621-1550-2-3-145HA05-HP358	30966402
16,00	16	133	83	63	48	SCD621-1600-2-3-145HA05-HP358	30966404
16,50	18	143	93	71	48	SCD621-1650-2-3-145HA05-HP358	30966405
17,00	18	143	93	71	48	SCD621-1700-2-3-145HA05-HP358	30966407
17,50	18	143	93	71	48	SCD621-1750-2-3-145HA05-HP358	30966408

Prosegue alla pagina seguente.

MEGA-Speed-Drill-Steel | Punta elicoidale in metallo duro integrale SCD621 (5xD), adduzione interna del refrigerante

Dimensioni						Forma del codolo HA	
d ₁ h7	d ₂ h6	l ₁	l ₂	l ₃	l ₄	Specifiche	Codice
18,00	18	143	93	71	48	SCD621-1800-2-3-145HA05-HP358	30966410
18,50	20	153	101	77	50	SCD621-1850-2-3-145HA05-HP358	30966411
19,80	20	153	101	77	50	SCD621-1980-2-3-145HA05-HP358	30966415
20,00	20	153	101	77	50	SCD621-2000-2-3-145HA05-HP358	30966416

Caratteristiche configurabili

**Diametro:**

Diametro a libera scelta a passi da 0,01 mm

**Forma del codolo:**

Forma del codolo: HB | HE

Specifiche:

SCD621-[diametro]-2-3-145[forma del codolo]05-HP358

Esempio:

SCD621-0431-2-3-145HE05-HP358

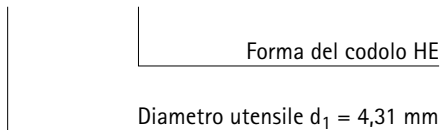

Dimensioni serie configurabile

d ₁ min.	d ₁ max.	d ₂ h6	l ₁	l ₂	l ₃	l ₄
3,00	3,70	6	66	28	23	36
3,71	4,70	6	74	36	29	36
4,71	6,00	6	82	44	35	36
6,01	6,80	8	91	53	43	36
6,81	8,00	8	91	53	43	36
8,01	9,00	10	103	61	49	40
9,01	10,00	10	103	61	49	40
10,01	11,00	12	118	71	56	45
11,01	12,00	12	118	71	56	45
12,01	14,00	14	124	77	60	45
14,01	16,00	16	133	83	63	48
16,01	18,00	18	143	93	71	48
18,01	20,00	20	153	101	77	50

Misure in mm.

Per i parametri di lavorazione consigliati, vedere la fine del capitolo.

Versioni speciali e altri rivestimenti disponibili su richiesta.

MEGA-Speed-Drill-Steel

Punta elicoidale in metallo duro integrale

SCD621 (8xD), adduzione interna del refrigerante, prodotto successivo a MEGA-Speed-Drill-Steel (SCD22)

Versione:

Diametro punta: 3,00 – 20,00 mm
 Tolleranza di foratura: IT 9 (raggiungibile)
 Materiale da taglio: HP358
 Numero di taglianti: 2
 Numero margini di guida: 3
 Angolo tra taglianti: 145°
 Angolo dell'elica: 30°

Applicazione:

Per lavorazioni ad alta velocità.

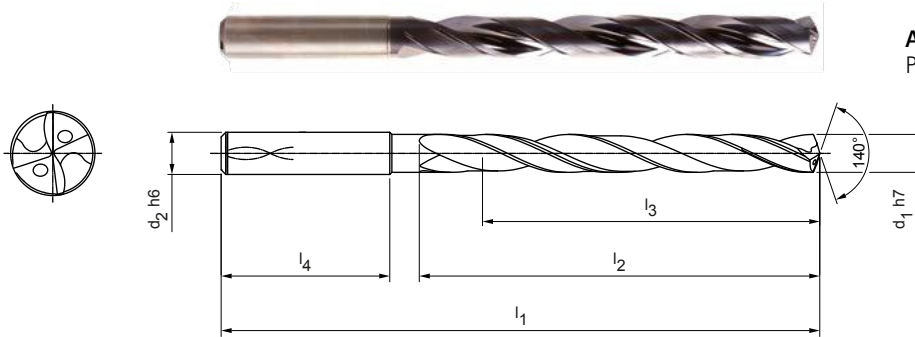

Serie selezionata per il magazzino con forma del codolo HA

Dimensioni						Forma del codolo HA	
d ₁ h7	d ₂ h6	l ₁	l ₂	l ₃	l ₄	Specifiche	Codice
3,00	6	72	34	29	36	SCD621-0300-2-3-145HA08-HP358	31036147
3,10	6	72	34	29	36	SCD621-0310-2-3-145HA08-HP358	31036148
3,20	6	72	34	29	36	SCD621-0320-2-3-145HA08-HP358	31036149
3,30	6	72	34	29	36	SCD621-0330-2-3-145HA08-HP358	31036150
3,40	6	72	34	29	36	SCD621-0340-2-3-145HA08-HP358	31036151
3,50	6	72	34	29	36	SCD621-0350-2-3-145HA08-HP358	31036152
3,70	6	72	34	29	36	SCD621-0370-2-3-145HA08-HP358	31036154
4,00	6	81	43	36	36	SCD621-0400-2-3-145HA08-HP358	31036157
4,10	6	81	43	36	36	SCD621-0410-2-3-145HA08-HP358	31036158
4,20	6	81	43	36	36	SCD621-0420-2-3-145HA08-HP358	31036159
4,30	6	81	43	36	36	SCD621-0430-2-3-145HA08-HP358	31036160
4,50	6	81	43	36	36	SCD621-0450-2-3-145HA08-HP358	31036162
4,65	6	81	43	36	36	SCD621-0465-2-3-145HA08-HP358	31307542
4,80	6	95	57	48	36	SCD621-0480-2-3-145HA08-HP358	31036165
4,90	6	95	57	48	36	SCD621-0490-2-3-145HA08-HP358	31036166
5,00	6	95	57	48	36	SCD621-0500-2-3-145HA08-HP358	31036167
5,10	6	95	57	48	36	SCD621-0510-2-3-145HA08-HP358	31036168
5,20	6	95	57	48	36	SCD621-0520-2-3-145HA08-HP358	31036169
5,40	6	95	57	48	36	SCD621-0540-2-3-145HA08-HP358	31036171
5,50	6	95	57	48	36	SCD621-0550-2-3-145HA08-HP358	31036172
5,55	6	95	57	48	36	SCD621-0555-2-3-145HA08-HP358	31307543
5,60	6	95	57	48	36	SCD621-0560-2-3-145HA08-HP358	31036173
5,80	6	95	57	48	36	SCD621-0580-2-3-145HA08-HP358	31036175
5,90	6	95	57	48	36	SCD621-0590-2-3-145HA08-HP358	31036176
6,00	6	95	57	48	36	SCD621-0600-2-3-145HA08-HP358	31036177
6,10	8	114	76	64	36	SCD621-0610-2-3-145HA08-HP358	31036178
6,20	8	114	76	64	36	SCD621-0620-2-3-145HA08-HP358	31036179
6,50	8	114	76	64	36	SCD621-0650-2-3-145HA08-HP358	31036182
6,80	8	114	76	64	36	SCD621-0680-2-3-145HA08-HP358	31036185
6,90	8	114	76	64	36	SCD621-0690-2-3-145HA08-HP358	31036186
7,00	8	114	76	64	36	SCD621-0700-2-3-145HA08-HP358	31036187
7,50	8	114	76	64	36	SCD621-0750-2-3-145HA08-HP358	31036192
7,80	8	114	76	64	36	SCD621-0780-2-3-145HA08-HP358	31036195
8,00	8	114	76	64	36	SCD621-0800-2-3-145HA08-HP358	31036197
8,10	10	142	95	80	40	SCD621-0810-2-3-145HA08-HP358	31036198

MEGA-Speed-Drill-Steel | Punta elicoidale in metallo duro integrale SCD621 (8xD), adduzione interna del refrigerante

Dimensioni						Forma del codolo HA	
d ₁ h7	d ₂ h6	l ₁	l ₂	l ₃	l ₄	Specifiche	Codice
8,50	10	142	95	80	40	SCD621-0850-2-3-145HA08-HP358	31036202
9,00	10	142	95	80	40	SCD621-0900-2-3-145HA08-HP358	31036207
9,50	10	142	95	80	40	SCD621-0950-2-3-145HA08-HP358	31036212
9,80	10	142	95	80	40	SCD621-0980-2-3-145HA08-HP358	31036215
10,00	10	142	95	80	40	SCD621-1000-2-3-145HA08-HP358	31036217
10,20	12	162	114	96	45	SCD621-1020-2-3-145HA08-HP358	31036219
10,30	12	162	114	96	45	SCD621-1030-2-3-145HA08-HP358	31036220
10,50	12	162	114	96	45	SCD621-1050-2-3-145HA08-HP358	31036222
11,00	12	162	114	96	45	SCD621-1100-2-3-145HA08-HP358	31036227
11,80	12	162	114	96	45	SCD621-1180-2-3-145HA08-HP358	31036235
12,00	12	162	114	96	45	SCD621-1200-2-3-145HA08-HP358	31036237
12,50	14	178	133	112	45	SCD621-1250-2-3-145HA08-HP358	31036239
13,00	14	178	133	112	45	SCD621-1300-2-3-145HA08-HP358	31036241
13,50	14	178	133	112	45	SCD621-1350-2-3-145HA08-HP358	31036242
14,00	14	178	133	112	45	SCD621-1400-2-3-145HA08-HP358	31036244
15,00	16	203	152	128	48	SCD621-1500-2-3-145HA08-HP358	31036248
15,80	16	203	152	128	48	SCD621-1580-2-3-145HA08-HP358	31036251
16,00	16	203	152	128	48	SCD621-1600-2-3-145HA08-HP358	31036252
19,00	20	243	190	160	50	SCD621-1900-2-3-145HA08-HP358	31036261
19,80	20	243	190	160	50	SCD621-1980-2-3-145HA08-HP358	31036263

Caratteristiche configurabili



Diametro:
Diametro a libera scelta a passi da 0,01 mm



Forma del codolo:
Forma del codolo: HB | HE

Specifiche:
SCD621-[diametro]-2-3-145[forma del codolo]08-HP358

Esempio:

SCD621-0431-2-3-145HE08-HP358

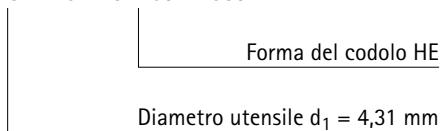

Dimensioni serie configurabile

d ₁ min.	d ₁ max.	d ₂ h6	l ₁	l ₂	l ₃	l ₄
3,00	3,70	6	72	34	29	36
3,71	4,70	6	81	43	36	36
4,71	6,00	6	95	57	48	36
6,01	6,80	8	114	76	64	36
6,81	8,00	8	114	76	64	36
8,01	9,00	10	142	95	80	40
9,01	10,00	10	142	95	80	40
10,01	11,00	12	162	114	96	45
11,01	12,00	12	162	114	96	45
12,01	14,00	14	178	133	112	45
14,01	16,00	16	203	152	128	48
16,01	18,00	18	222	171	144	48
18,01	20,00	20	243	190	160	50

Misure in mm.

Per i parametri di lavorazione consigliati, vedere la fine del capitolo.

Versioni speciali e altri rivestimenti disponibili su richiesta.

MEGA-Speed-Drill-Steel

Punta elicoidale in metallo duro integrale

SCD621 (12xD), adduzione interna del refrigerante, prodotto successivo a MEGA-Speed-Drill-Steel (SCD22)

Versione:

Diametro punta: 3,00 – 20,00 mm
 Tolleranza di foratura: \geq IT 9
 Materiale da taglio: HP358
 Numero di taglienti: 2
 Numero margini di guida: 3
 Angolo tra taglienti: 145°
 Angolo dell'elica: 30°

Applicazione:

Per lavorazioni ad alta velocità.

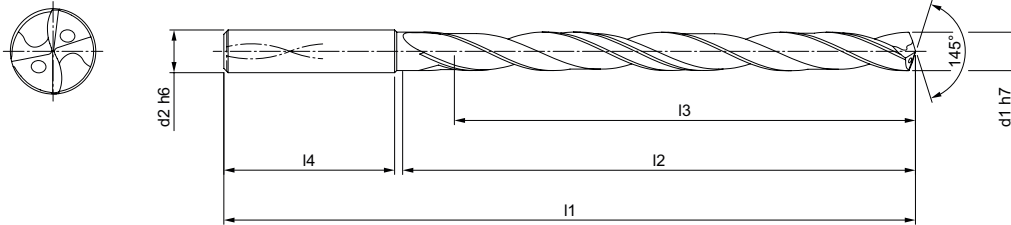

Serie selezionata per il magazzino con forma del codolo HA

Dimensioni						Forma del codolo HA	
d ₁ h7	d ₂ h6	l ₁	l ₂	l ₃	l ₄	Specifiche	Codice
3,00	6	92	54	48	36	SCD621-0300-2-3-145HA12-HP358	31239148
3,20	6	92	54	48	36	SCD621-0320-2-3-145HA12-HP358	31239150
3,30	6	92	54	48	36	SCD621-0330-2-3-145HA12-HP358	31239151
3,40	6	92	54	48	36	SCD621-0340-2-3-145HA12-HP358	31239152
3,50	6	92	54	48	36	SCD621-0350-2-3-145HA12-HP358	31239153
3,70	6	92	54	48	36	SCD621-0370-2-3-145HA12-HP358	31239155
4,00	6	102	64	58	36	SCD621-0400-2-3-145HA12-HP358	31239158
4,10	6	102	64	58	36	SCD621-0410-2-3-145HA12-HP358	31239159
4,20	6	102	64	58	36	SCD621-0420-2-3-145HA12-HP358	31239160
4,30	6	102	64	58	36	SCD621-0430-2-3-145HA12-HP358	31239161
4,50	6	102	64	58	36	SCD621-0450-2-3-145HA12-HP358	31239163
4,80	6	116	78	70	36	SCD621-0480-2-3-145HA12-HP358	31239166
5,00	6	116	78	70	36	SCD621-0500-2-3-145HA12-HP358	31239168
5,10	6	116	78	70	36	SCD621-0510-2-3-145HA12-HP358	31239169
5,20	6	116	78	70	36	SCD621-0520-2-3-145HA12-HP358	31239170
5,40	6	116	78	70	36	SCD621-0540-2-3-145HA12-HP358	31239172
5,50	6	116	78	70	36	SCD621-0550-2-3-145HA12-HP358	31239173
5,80	6	116	78	70	36	SCD621-0580-2-3-145HA12-HP358	31239176
6,00	6	116	78	70	36	SCD621-0600-2-3-145HA12-HP358	31239178
6,10	8	146	108	94	36	SCD621-0610-2-3-145HA12-HP358	31239179
6,50	8	146	108	94	36	SCD621-0650-2-3-145HA12-HP358	31239183
6,80	8	146	108	94	36	SCD621-0680-2-3-145HA12-HP358	31239186
7,00	8	146	108	94	36	SCD621-0700-2-3-145HA12-HP358	31239188
7,50	8	146	108	94	36	SCD621-0750-2-3-145HA12-HP358	31239193
7,80	8	146	108	94	36	SCD621-0780-2-3-145HA12-HP358	31239196
8,00	8	146	108	94	36	SCD621-0800-2-3-145HA12-HP358	31239198
8,50	10	162	120	110	40	SCD621-0850-2-3-145HA12-HP358	31239203
9,00	10	162	120	110	40	SCD621-0900-2-3-145HA12-HP358	31239208
9,50	10	162	120	110	40	SCD621-0950-2-3-145HA12-HP358	31239213
9,80	10	162	120	110	40	SCD621-0980-2-3-145HA12-HP358	31239216
10,00	10	162	120	110	40	SCD621-1000-2-3-145HA12-HP358	31239218
10,20	12	204	156	142	45	SCD621-1020-2-3-145HA12-HP358	31239220
10,50	12	204	156	142	45	SCD621-1050-2-3-145HA12-HP358	31239223
11,00	12	204	156	142	45	SCD621-1100-2-3-145HA12-HP358	31239228
11,80	12	204	156	142	45	SCD621-1180-2-3-145HA12-HP358	31239236

MEGA-Speed-Drill-Steel | Punta elicoidale in metallo duro integrale SCD621 (12xD), adduzione interna del refrigerante

Dimensioni						Forma del codolo HA	
d ₁ h7	d ₂ h6	l ₁	l ₂	l ₃	l ₄	Specifiche	Codice
12,00	12	204	156	142	45	SCD621-1200-2-3-145HA12-HP358	31239238
12,50	14	230	182	166	45	SCD621-1250-2-3-145HA12-HP358	31239240
13,00	14	230	182	166	45	SCD621-1300-2-3-145HA12-HP358	31239242
13,50	14	230	182	166	45	SCD621-1350-2-3-145HA12-HP358	31239243
14,00	14	230	182	166	45	SCD621-1400-2-3-145HA12-HP358	31239245
15,00	16	260	208	192	48	SCD621-1500-2-3-145HA12-HP358	31239248
16,00	16	260	208	192	48	SCD621-1600-2-3-145HA12-HP358	31239253

Caratteristiche configurabili

**Diametro:**

Diametro a libera scelta a passi da 0,01 mm

**Forma del codolo:**

Forma del codolo: HB | HE

Specifiche:

SCD621-[diametro]-2-3-145[forma del codolo]12-HP358

Esempio:

SCD621-0431-2-3-145HE12-HP358

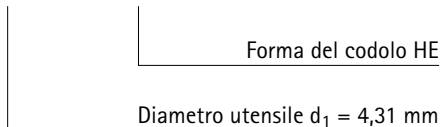

Dimensioni serie configurabile

d ₁ min.	d ₁ max.	d ₂ h6	l ₁	l ₂	l ₃	l ₄
3,00	3,70	6	92	54	48	36
3,71	4,70	6	102	64	58	36
4,71	6,00	6	116	78	70	36
6,01	6,80	8	146	108	94	36
6,81	8,00	8	146	108	94	36
8,01	9,00	10	162	120	110	40
9,01	10,00	10	162	120	110	40
10,01	11,00	12	204	156	142	45
11,01	12,00	12	204	156	142	45
12,01	14,00	14	230	182	166	45
14,01	16,00	16	260	208	192	48
16,01	18,00	18	285	234	216	48
18,01	20,00	20	310	258	240	50

Misure in mm.

Per i parametri di lavorazione consigliati, vedere la fine del capitolo.

Versioni speciali e altri rivestimenti disponibili su richiesta.

MEGA-180°-Drill

Punta elicoidale in metallo duro integrale
SCD231 (3xD), adduzione interna del refrigerante

Versione:

Diametro punta: 3,00 – 20,00 mm
Tolleranza di foratura: \geq IT 9
Materiale da taglio: HP230
Numero di taglienti: 2
Numero margini di guida: 4
Angolo tra taglienti: 180°
Angolo dell'elica: 30°

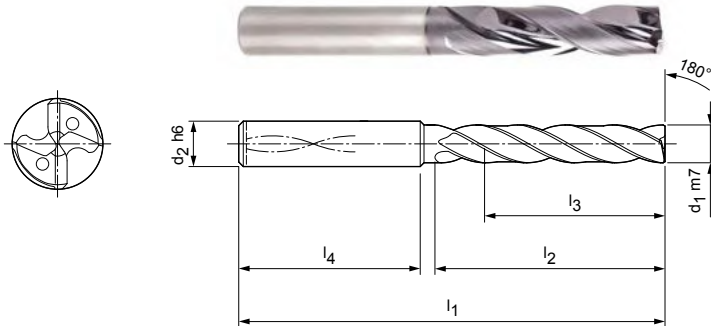

Serie selezionata per il magazzino con forma del codolo HA

Dimensioni						Forma del codolo HA	
d ₁ m7	d ₂ h6	l ₁	l ₂	l ₃	l ₄	Specifiche	Codice
3,00	6	62	20	14	36	SCD231-0300-2-4-180HA03-HP230	30382647
3,10	6	62	20	14	36	SCD231-0310-2-4-180HA03-HP230	30382648
3,20	6	62	20	14	36	SCD231-0320-2-4-180HA03-HP230	30382649
3,30	6	62	20	14	36	SCD231-0330-2-4-180HA03-HP230	30382650
3,40	6	62	20	14	36	SCD231-0340-2-4-180HA03-HP230	30382651
3,50	6	62	20	14	36	SCD231-0350-2-4-180HA03-HP230	30382652
3,60	6	62	20	14	36	SCD231-0360-2-4-180HA03-HP230	30382653
3,70	6	62	20	14	36	SCD231-0370-2-4-180HA03-HP230	30382654
3,80	6	66	24	17	36	SCD231-0380-2-4-180HA03-HP230	30382655
3,90	6	66	24	17	36	SCD231-0390-2-4-180HA03-HP230	30382656
4,00	6	66	24	17	36	SCD231-0400-2-4-180HA03-HP230	30382657
4,10	6	66	24	17	36	SCD231-0410-2-4-180HA03-HP230	30382658
4,20	6	66	24	17	36	SCD231-0420-2-4-180HA03-HP230	30382659
4,30	6	66	24	17	36	SCD231-0430-2-4-180HA03-HP230	30382660
4,40	6	66	24	17	36	SCD231-0440-2-4-180HA03-HP230	30382661
4,50	6	66	24	17	36	SCD231-0450-2-4-180HA03-HP230	30382662
4,60	6	66	24	17	36	SCD231-0460-2-4-180HA03-HP230	30382663
4,65	6	66	24	17	36	SCD231-0465-2-4-180HA03-HP230	30382664
4,70	6	66	24	17	36	SCD231-0470-2-4-180HA03-HP230	30382665
4,80	6	66	28	20	36	SCD231-0480-2-4-180HA03-HP230	30382666
4,90	6	66	28	20	36	SCD231-0490-2-4-180HA03-HP230	30382667
5,00	6	66	28	20	36	SCD231-0500-2-4-180HA03-HP230	30382668
5,10	6	66	28	20	36	SCD231-0510-2-4-180HA03-HP230	30382669
5,20	6	66	28	20	36	SCD231-0520-2-4-180HA03-HP230	30382670
5,30	6	66	28	20	36	SCD231-0530-2-4-180HA03-HP230	30382671
5,40	6	66	28	20	36	SCD231-0540-2-4-180HA03-HP230	30382672
5,50	6	66	28	20	36	SCD231-0550-2-4-180HA03-HP230	30382673
5,55	6	66	28	20	36	SCD231-0555-2-4-180HA03-HP230	30382674
5,60	6	66	28	20	36	SCD231-0560-2-4-180HA03-HP230	30382675
5,70	6	66	28	20	36	SCD231-0570-2-4-180HA03-HP230	30382676
5,80	6	66	28	20	36	SCD231-0580-2-4-180HA03-HP230	30382677
5,90	6	66	28	20	36	SCD231-0590-2-4-180HA03-HP230	30382678
6,00	6	66	28	20	36	SCD231-0600-2-4-180HA03-HP230	30382679
6,10	8	79	34	24	36	SCD231-0610-2-4-180HA03-HP230	30382680
6,20	8	79	34	24	36	SCD231-0620-2-4-180HA03-HP230	30382681

MEGA-180°-Drill | Punta elicoidale in metallo duro integrale SCD231 (3xD), adduzione interna del refrigerante

Dimensioni						Forma del codolo HA	
d ₁ m7	d ₂ h6	l ₁	l ₂	l ₃	l ₄	Specifiche	Codice
6,30	8	79	34	24	36	SCD231-0630-2-4-180HA03-HP230	30382682
6,40	8	79	34	24	36	SCD231-0640-2-4-180HA03-HP230	30382683
6,50	8	79	34	24	36	SCD231-0650-2-4-180HA03-HP230	30382684
6,60	8	79	34	24	36	SCD231-0660-2-4-180HA03-HP230	30382685
6,70	8	79	34	24	36	SCD231-0670-2-4-180HA03-HP230	30382686
6,80	8	79	34	24	36	SCD231-0680-2-4-180HA03-HP230	30382687
6,90	8	79	34	24	36	SCD231-0690-2-4-180HA03-HP230	30382688
7,00	8	79	34	24	36	SCD231-0700-2-4-180HA03-HP230	30382689
7,10	8	79	41	29	36	SCD231-0710-2-4-180HA03-HP230	30382690
7,20	8	79	41	29	36	SCD231-0720-2-4-180HA03-HP230	30382691
7,30	8	79	41	29	36	SCD231-0730-2-4-180HA03-HP230	30382692
7,40	8	79	41	29	36	SCD231-0740-2-4-180HA03-HP230	30382693
7,50	8	79	41	29	36	SCD231-0750-2-4-180HA03-HP230	30382694
7,60	8	79	41	29	36	SCD231-0760-2-4-180HA03-HP230	30382695
7,70	8	79	41	29	36	SCD231-0770-2-4-180HA03-HP230	30382696
7,80	8	79	41	29	36	SCD231-0780-2-4-180HA03-HP230	30382697
7,90	8	79	41	29	36	SCD231-0790-2-4-180HA03-HP230	30382698
8,00	8	79	41	29	36	SCD231-0800-2-4-180HA03-HP230	30382699
8,10	10	89	47	35	40	SCD231-0810-2-4-180HA03-HP230	30382700
8,20	10	89	47	35	40	SCD231-0820-2-4-180HA03-HP230	30382701
8,30	10	89	47	35	40	SCD231-0830-2-4-180HA03-HP230	30382702
8,40	10	89	47	35	40	SCD231-0840-2-4-180HA03-HP230	30382703
8,50	10	89	47	35	40	SCD231-0850-2-4-180HA03-HP230	30382704
8,60	10	89	47	35	40	SCD231-0860-2-4-180HA03-HP230	30382705
8,70	10	89	47	35	40	SCD231-0870-2-4-180HA03-HP230	30382706
8,80	10	89	47	35	40	SCD231-0880-2-4-180HA03-HP230	30382707
8,90	10	89	47	35	40	SCD231-0890-2-4-180HA03-HP230	30382708
9,00	10	89	47	35	40	SCD231-0900-2-4-180HA03-HP230	30382709
9,10	10	89	47	35	40	SCD231-0910-2-4-180HA03-HP230	30382710
9,20	10	89	47	35	40	SCD231-0920-2-4-180HA03-HP230	30382711
9,30	10	89	47	35	40	SCD231-0930-2-4-180HA03-HP230	30382712
9,40	10	89	47	35	40	SCD231-0940-2-4-180HA03-HP230	30382713
9,50	10	89	47	35	40	SCD231-0950-2-4-180HA03-HP230	30382714
9,60	10	89	47	35	40	SCD231-0960-2-4-180HA03-HP230	30382715
9,70	10	89	47	35	40	SCD231-0970-2-4-180HA03-HP230	30382716
9,80	10	89	47	35	40	SCD231-0980-2-4-180HA03-HP230	30382717
9,90	10	89	47	35	40	SCD231-0990-2-4-180HA03-HP230	30382718
10,00	10	89	47	35	40	SCD231-1000-2-4-180HA03-HP230	30382719
10,10	12	100	53	38	45	SCD231-1010-2-4-180HA03-HP230	30382720
10,20	12	100	53	38	45	SCD231-1020-2-4-180HA03-HP230	30382721
10,30	12	100	53	38	45	SCD231-1030-2-4-180HA03-HP230	30382722
10,40	12	100	53	38	45	SCD231-1040-2-4-180HA03-HP230	30382723
10,50	12	100	53	38	45	SCD231-1050-2-4-180HA03-HP230	30382724
10,60	12	100	53	38	45	SCD231-1060-2-4-180HA03-HP230	30382725
10,70	12	100	53	38	45	SCD231-1070-2-4-180HA03-HP230	30382726
10,80	12	100	53	38	45	SCD231-1080-2-4-180HA03-HP230	30382727
11,00	12	100	53	38	45	SCD231-1100-2-4-180HA03-HP230	30382729
11,10	12	100	53	38	45	SCD231-1110-2-4-180HA03-HP230	30382730
11,20	12	100	53	38	45	SCD231-1120-2-4-180HA03-HP230	30382731
11,30	12	100	53	38	45	SCD231-1130-2-4-180HA03-HP230	30382732
11,40	12	100	53	38	45	SCD231-1140-2-4-180HA03-HP230	30382733
11,50	12	100	53	38	45	SCD231-1150-2-4-180HA03-HP230	30382734
11,60	12	100	53	38	45	SCD231-1160-2-4-180HA03-HP230	30382735
11,70	12	100	53	38	45	SCD231-1170-2-4-180HA03-HP230	30382736
11,80	12	100	53	38	45	SCD231-1180-2-4-180HA03-HP230	30382737
11,90	12	100	53	38	45	SCD231-1190-2-4-180HA03-HP230	30382738
12,00	12	100	53	38	45	SCD231-1200-2-4-180HA03-HP230	30382739

MEGA-180°-Drill | Punta elicoidale in metallo duro integrale SCD231 (3xD), adduzione interna del refrigerante

Dimensioni						Forma del codolo HA	
d ₁ m7	d ₂ h6	l ₁	l ₂	l ₃	l ₄	Specifiche	Codice
12,50	14	105	58	41	45	SCD231-1250-2-4-180HA03-HP230	30382740
12,70	14	105	58	41	45	SCD231-1270-2-4-180HA03-HP230	30852019
12,80	14	105	58	41	45	SCD231-1280-2-4-180HA03-HP230	30382741
13,00	14	105	58	41	45	SCD231-1300-2-4-180HA03-HP230	30382742
13,50	14	105	58	41	45	SCD231-1350-2-4-180HA03-HP230	30382743
13,80	14	105	58	41	45	SCD231-1380-2-4-180HA03-HP230	30382744
14,00	14	105	58	41	45	SCD231-1400-2-4-180HA03-HP230	30382745
14,50	16	113	63	43	48	SCD231-1450-2-4-180HA03-HP230	30382746
14,80	16	113	63	43	48	SCD231-1480-2-4-180HA03-HP230	30382747
15,00	16	113	63	43	48	SCD231-1500-2-4-180HA03-HP230	30382748
15,50	16	113	63	43	48	SCD231-1550-2-4-180HA03-HP230	30382749
15,80	16	113	63	43	48	SCD231-1580-2-4-180HA03-HP230	30382750
16,00	16	113	63	43	48	SCD231-1600-2-4-180HA03-HP230	30382751
16,50	18	121	71	49	48	SCD231-1650-2-4-180HA03-HP230	30382752
16,80	18	121	71	49	48	SCD231-1680-2-4-180HA03-HP230	30382753
17,00	18	121	71	49	48	SCD231-1700-2-4-180HA03-HP230	30382754
17,50	18	121	71	49	48	SCD231-1750-2-4-180HA03-HP230	30382755
18,00	18	121	71	49	48	SCD231-1800-2-4-180HA03-HP230	30382757
18,50	20	129	77	53	50	SCD231-1850-2-4-180HA03-HP230	30382758
18,80	20	129	77	53	50	SCD231-1880-2-4-180HA03-HP230	30382759
19,00	20	129	77	53	50	SCD231-1900-2-4-180HA03-HP230	30382760
19,50	20	129	77	53	50	SCD231-1950-2-4-180HA03-HP230	30382761
20,00	20	129	77	53	50	SCD231-2000-2-4-180HA03-HP230	30382763

Caratteristiche configurabili

**Diametro:**

Diametro a libera scelta a passi da 0,01 mm

**Forma del codolo:**

Forma del codolo: HB | HE

Specifiche:

SCD231-[diametro]-2-4-180[forma del codolo]03-HP230

Esempio:

SCD231-0431-2-4-180HE03-HP230

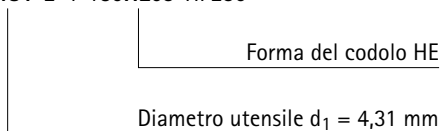

Dimensioni serie configurabile

d ₁ min.	d ₁ max.	d ₂ h6	l ₁	l ₂	l ₃	l ₄
3,00	3,70	6	62	20	14	36
3,71	4,70	6	66	24	17	36
4,71	6,00	6	66	28	20	36
6,01	6,80	8	79	34	24	36
6,81	8,00	8	79	41	29	36
8,01	10,00	10	89	47	35	40
10,01	12,00	12	100	53	38	45
12,01	14,00	14	105	58	41	45
14,01	16,00	16	113	63	43	48
16,01	18,00	18	121	71	49	48
18,01	20,00	20	129	77	53	50

Misure in mm.

Per i parametri di lavorazione consigliati, vedere la fine del capitolo.

Versioni speciali e altri rivestimenti disponibili su richiesta.

MEGA-180°-Drill

Punta elicoidale in metallo duro integrale
SCD231 (5xD), adduzione interna del refrigerante

Versione:

Diametro punta: 3,00 – 20,00 mm
Tolleranza di foratura: \geq IT 9
Materiale da taglio: HP230
Numero di taglienti: 2
Numero margini di guida: 4
Angolo tra taglienti: 180°
Angolo dell'elica: 30°

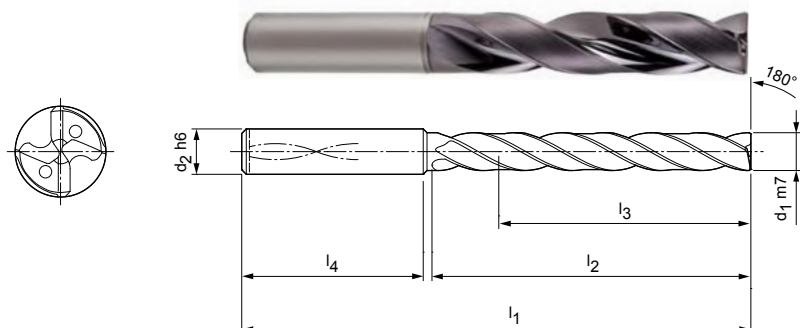

Serie selezionata per il magazzino con forma del codolo HA

Dimensioni						Forma del codolo HA	
d_1 m7	d_2 h6	l_1	l_2	l_3	l_4	Specifiche	Codice
3,00	6	66	28	23	36	SCD231-0300-2-4-180HA05-HP230	30382764
3,10	6	66	28	23	36	SCD231-0310-2-4-180HA05-HP230	30382765
3,20	6	66	28	23	36	SCD231-0320-2-4-180HA05-HP230	30382766
3,30	6	66	28	23	36	SCD231-0330-2-4-180HA05-HP230	30382767
3,40	6	66	28	23	36	SCD231-0340-2-4-180HA05-HP230	30382768
3,50	6	66	28	23	36	SCD231-0350-2-4-180HA05-HP230	30382769
3,60	6	66	28	23	36	SCD231-0360-2-4-180HA05-HP230	30382770
3,70	6	66	28	23	36	SCD231-0370-2-4-180HA05-HP230	30382771
3,80	6	74	36	29	36	SCD231-0380-2-4-180HA05-HP230	30382772
3,90	6	74	36	29	36	SCD231-0390-2-4-180HA05-HP230	30382773
4,00	6	74	36	29	36	SCD231-0400-2-4-180HA05-HP230	30382774
4,10	6	74	36	29	36	SCD231-0410-2-4-180HA05-HP230	30382775
4,20	6	74	36	29	36	SCD231-0420-2-4-180HA05-HP230	30382776
4,30	6	74	36	29	36	SCD231-0430-2-4-180HA05-HP230	30382777
4,40	6	74	36	29	36	SCD231-0440-2-4-180HA05-HP230	30382778
4,50	6	74	36	29	36	SCD231-0450-2-4-180HA05-HP230	30382779
4,60	6	74	36	29	36	SCD231-0460-2-4-180HA05-HP230	30382780
4,80	6	82	44	35	36	SCD231-0480-2-4-180HA05-HP230	30382783
4,90	6	82	44	35	36	SCD231-0490-2-4-180HA05-HP230	30382784
5,00	6	82	44	35	36	SCD231-0500-2-4-180HA05-HP230	30382785
5,10	6	82	44	35	36	SCD231-0510-2-4-180HA05-HP230	30382786
5,20	6	82	44	35	36	SCD231-0520-2-4-180HA05-HP230	30382787
5,30	6	82	44	35	36	SCD231-0530-2-4-180HA05-HP230	30382788
5,40	6	82	44	35	36	SCD231-0540-2-4-180HA05-HP230	30382789
5,50	6	82	44	35	36	SCD231-0550-2-4-180HA05-HP230	30382790
5,55	6	82	44	35	36	SCD231-0555-2-4-180HA05-HP230	30382791
5,60	6	82	44	35	36	SCD231-0560-2-4-180HA05-HP230	30382792
5,70	6	82	44	35	36	SCD231-0570-2-4-180HA05-HP230	30382793
5,80	6	82	44	35	36	SCD231-0580-2-4-180HA05-HP230	30382794
5,90	6	82	44	35	36	SCD231-0590-2-4-180HA05-HP230	30382795
6,00	6	82	44	35	36	SCD231-0600-2-4-180HA05-HP230	30382796
6,10	8	91	53	43	36	SCD231-0610-2-4-180HA05-HP230	30382797
6,20	8	91	53	43	36	SCD231-0620-2-4-180HA05-HP230	30382798
6,30	8	91	53	43	36	SCD231-0630-2-4-180HA05-HP230	30382799
6,40	8	91	53	43	36	SCD231-0640-2-4-180HA05-HP230	30382800

MEGA-180°-Drill | Punta elicoidale in metallo duro integrale SCD231 (5xD), adduzione interna del refrigerante

Dimensioni						Forma del codolo HA	
d ₁ m7	d ₂ h6	l ₁	l ₂	l ₃	l ₄	Specifiche	Codice
6,50	8	91	53	43	36	SCD231-0650-2-4-180HA05-HP230	30382801
6,60	8	91	53	43	36	SCD231-0660-2-4-180HA05-HP230	30382802
6,70	8	91	53	43	36	SCD231-0670-2-4-180HA05-HP230	30382803
6,80	8	91	53	43	36	SCD231-0680-2-4-180HA05-HP230	30382804
6,90	8	91	53	43	36	SCD231-0690-2-4-180HA05-HP230	30382805
7,00	8	91	53	43	36	SCD231-0700-2-4-180HA05-HP230	30382806
7,10	8	91	53	43	36	SCD231-0710-2-4-180HA05-HP230	30382807
7,20	8	91	53	43	36	SCD231-0720-2-4-180HA05-HP230	30382808
7,30	8	91	53	43	36	SCD231-0730-2-4-180HA05-HP230	30382809
7,40	8	91	53	43	36	SCD231-0740-2-4-180HA05-HP230	30382810
7,50	8	91	53	43	36	SCD231-0750-2-4-180HA05-HP230	30382811
7,60	8	91	53	43	36	SCD231-0760-2-4-180HA05-HP230	30382812
7,80	8	91	53	43	36	SCD231-0780-2-4-180HA05-HP230	30382814
7,90	8	91	53	43	36	SCD231-0790-2-4-180HA05-HP230	30382815
8,00	8	91	53	43	36	SCD231-0800-2-4-180HA05-HP230	30382816
8,10	10	103	61	49	40	SCD231-0810-2-4-180HA05-HP230	30382817
8,20	10	103	61	49	40	SCD231-0820-2-4-180HA05-HP230	30382818
8,30	10	103	61	49	40	SCD231-0830-2-4-180HA05-HP230	30382819
8,40	10	103	61	49	40	SCD231-0840-2-4-180HA05-HP230	30382820
8,50	10	103	61	49	40	SCD231-0850-2-4-180HA05-HP230	30382821
8,60	10	103	61	49	40	SCD231-0860-2-4-180HA05-HP230	30382822
8,70	10	103	61	49	40	SCD231-0870-2-4-180HA05-HP230	30382823
8,80	10	103	61	49	40	SCD231-0880-2-4-180HA05-HP230	30382824
8,90	10	103	61	49	40	SCD231-0890-2-4-180HA05-HP230	30382825
9,00	10	103	61	49	40	SCD231-0900-2-4-180HA05-HP230	30382826
9,10	10	103	61	49	40	SCD231-0910-2-4-180HA05-HP230	30382827
9,20	10	103	61	49	40	SCD231-0920-2-4-180HA05-HP230	30382828
9,30	10	103	61	49	40	SCD231-0930-2-4-180HA05-HP230	30382829
9,40	10	103	61	49	40	SCD231-0940-2-4-180HA05-HP230	30382830
9,50	10	103	61	49	40	SCD231-0950-2-4-180HA05-HP230	30382831
9,60	10	103	61	49	40	SCD231-0960-2-4-180HA05-HP230	30382832
9,70	10	103	61	49	40	SCD231-0970-2-4-180HA05-HP230	30382833
9,80	10	103	61	49	40	SCD231-0980-2-4-180HA05-HP230	30382834
9,90	10	103	61	49	40	SCD231-0990-2-4-180HA05-HP230	30382835
10,00	10	103	61	49	40	SCD231-1000-2-4-180HA05-HP230	30382836
10,10	12	116	69	54	45	SCD231-1010-2-4-180HA05-HP230	30382838
10,20	12	116	69	54	45	SCD231-1020-2-4-180HA05-HP230	30382840
10,30	12	116	69	54	45	SCD231-1030-2-4-180HA05-HP230	30382841
10,40	12	116	69	54	45	SCD231-1040-2-4-180HA05-HP230	30382842
10,50	12	116	69	54	45	SCD231-1050-2-4-180HA05-HP230	30382843
10,60	12	116	69	54	45	SCD231-1060-2-4-180HA05-HP230	30382844
10,65	12	116	69	54	45	SCD231-1065-2-4-180HA05-HP230	31198519
10,80	12	116	69	54	45	SCD231-1080-2-4-180HA05-HP230	30382846
11,00	12	116	69	54	45	SCD231-1100-2-4-180HA05-HP230	30382848
11,20	12	116	69	54	45	SCD231-1120-2-4-180HA05-HP230	30382850
11,50	12	116	69	54	45	SCD231-1150-2-4-180HA05-HP230	30382853
11,60	12	116	69	54	45	SCD231-1160-2-4-180HA05-HP230	30382854
11,70	12	116	69	54	45	SCD231-1170-2-4-180HA05-HP230	30382855
11,80	12	116	69	54	45	SCD231-1180-2-4-180HA05-HP230	30382856
12,00	12	116	69	54	45	SCD231-1200-2-4-180HA05-HP230	30382858
12,50	14	122	75	58	45	SCD231-1250-2-4-180HA05-HP230	30382859
12,80	14	122	75	58	45	SCD231-1280-2-4-180HA05-HP230	30382860
13,00	14	122	75	58	45	SCD231-1300-2-4-180HA05-HP230	30382861
13,50	14	122	75	58	45	SCD231-1350-2-4-180HA05-HP230	30382862
13,80	14	122	75	58	45	SCD231-1380-2-4-180HA05-HP230	30382863
14,00	14	122	75	58	45	SCD231-1400-2-4-180HA05-HP230	30382864
14,50	16	131	81	61	48	SCD231-1450-2-4-180HA05-HP230	30382865

MEGA-180°-Drill | Punta elicoidale in metallo duro integrale SCD231 (5xD), adduzione interna del refrigerante

Dimensioni						Forma del codolo HA	
d ₁ m7	d ₂ h6	l ₁	l ₂	l ₃	l ₄	Specifiche	Codice
14,80	16	131	81	61	48	SCD231-1480-2-4-180HA05-HP230	30382866
15,00	16	131	81	61	48	SCD231-1500-2-4-180HA05-HP230	30382867
15,50	16	131	81	61	48	SCD231-1550-2-4-180HA05-HP230	30382868
15,80	16	131	81	61	48	SCD231-1580-2-4-180HA05-HP230	30382869
16,00	16	131	81	61	48	SCD231-1600-2-4-180HA05-HP230	30382870
16,50	18	141	91	69	48	SCD231-1650-2-4-180HA05-HP230	30382871
17,00	18	141	91	69	48	SCD231-1700-2-4-180HA05-HP230	30382873
17,50	18	141	91	69	48	SCD231-1750-2-4-180HA05-HP230	30382874
17,80	18	141	91	69	48	SCD231-1780-2-4-180HA05-HP230	30382875
18,00	18	141	91	69	48	SCD231-1800-2-4-180HA05-HP230	30382876
18,50	20	151	99	75	50	SCD231-1850-2-4-180HA05-HP230	30382877
19,00	20	151	99	75	50	SCD231-1900-2-4-180HA05-HP230	30382879
19,80	20	151	99	75	50	SCD231-1980-2-4-180HA05-HP230	30382881
20,00	20	151	99	75	50	SCD231-2000-2-4-180HA05-HP230	30382882

Caratteristiche configurabili

**Diametro:**

Diametro a libera scelta a passi da 0,01 mm

**Forma del codolo:**

Forma del codolo: HB | HE

Specifiche:

SCD231-[diametro]-2-4-180[forma del codolo]05-HP230

Dimensioni serie configurabile

d ₁ min.	d ₁ max.	d ₂ h6	l ₁	l ₂	l ₃	l ₄
3,00	3,70	6	66	28	23	36
3,71	4,70	6	74	36	29	36
4,71	6,00	6	82	44	35	36
6,01	8,00	8	91	53	43	36
8,01	10,00	10	103	61	49	40
10,01	12,00	12	116	69	54	45
12,01	14,00	14	122	75	58	45
14,01	16,00	16	131	81	61	48
16,01	18,00	18	141	91	69	48
18,01	20,00	20	151	99	75	50

Esempio:

SCD231-0431-2-4-180HE05-HP230

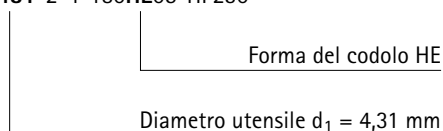

Misure in mm.

Per i parametri di lavorazione consigliati, vedere la fine del capitolo.

Versioni speciali e altri rivestimenti disponibili su richiesta.

ECU-Drill-Steel

Punta elicoidale in metallo duro integrale
SCD361 (3xD), adduzione interna del refrigerante

Versione:

Diametro punta: 3,00 - 20,00 mm
Tolleranza di foratura: \geq IT 9
Materiale da taglio: HP132
Numero di taglienti: 2
Angolo tra taglienti: 140°
Angolo dell'elica: 30°

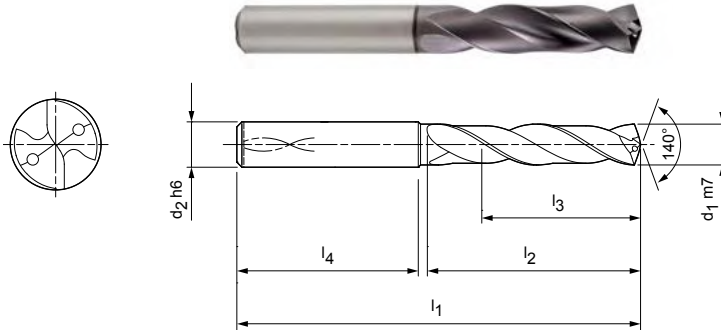

Serie selezionata per il magazzino con forma del codolo HA

Dimensioni						Forma del codolo HA	
d ₁ m7	d ₂ h6	l ₁	l ₂	l ₃	l ₄	Specifiche	Codice
3,00	6	62	20	14	36	SCD361-0300-2-2-140HA03-HP132	30421364
3,10	6	62	20	14	36	SCD361-0310-2-2-140HA03-HP132	30421365
3,20	6	62	20	14	36	SCD361-0320-2-2-140HA03-HP132	30421366
3,30	6	62	20	14	36	SCD361-0330-2-2-140HA03-HP132	30421368
3,40	6	62	20	14	36	SCD361-0340-2-2-140HA03-HP132	30421369
3,50	6	62	20	14	36	SCD361-0350-2-2-140HA03-HP132	30421370
3,70*	6	62	20	14	36	SCD361-0370-2-2-140HA03-HP132	30421372
3,80	6	66	24	17	36	SCD361-0380-2-2-140HA03-HP132	30421373
3,90	6	66	24	17	36	SCD361-0390-2-2-140HA03-HP132	30421374
4,00	6	66	24	17	36	SCD361-0400-2-2-140HA03-HP132	30421375
4,10	6	66	24	17	36	SCD361-0410-2-2-140HA03-HP132	30421376
4,20	6	66	24	17	36	SCD361-0420-2-2-140HA03-HP132	30421377
4,30	6	66	24	17	36	SCD361-0430-2-2-140HA03-HP132	30421379
4,40	6	66	24	17	36	SCD361-0440-2-2-140HA03-HP132	30421380
4,50	6	66	24	17	36	SCD361-0450-2-2-140HA03-HP132	30421381
4,60	6	66	24	17	36	SCD361-0460-2-2-140HA03-HP132	30421382
4,65*	6	66	24	17	36	SCD361-0465-2-2-140HA03-HP132	30421383
4,70	6	66	24	17	36	SCD361-0470-2-2-140HA03-HP132	30421384
4,80	6	66	28	20	36	SCD361-0480-2-2-140HA03-HP132	30421385
4,90	6	66	28	20	36	SCD361-0490-2-2-140HA03-HP132	30421386
5,00	6	66	28	20	36	SCD361-0500-2-2-140HA03-HP132	30421388
5,10	6	66	28	20	36	SCD361-0510-2-2-140HA03-HP132	30421390
5,20	6	66	28	20	36	SCD361-0520-2-2-140HA03-HP132	30421391
5,30	6	66	28	20	36	SCD361-0530-2-2-140HA03-HP132	30421392
5,40	6	66	28	20	36	SCD361-0540-2-2-140HA03-HP132	30421393
5,50	6	66	28	20	36	SCD361-0550-2-2-140HA03-HP132	30421394
5,55*	6	66	28	20	36	SCD361-0555-2-2-140HA03-HP132	30421395
5,60	6	66	28	20	36	SCD361-0560-2-2-140HA03-HP132	30421396
5,80	6	66	28	20	36	SCD361-0580-2-2-140HA03-HP132	30421399
5,90	6	66	28	20	36	SCD361-0590-2-2-140HA03-HP132	30421400
6,00	6	66	28	20	36	SCD361-0600-2-2-140HA03-HP132	30421401
6,10	8	79	34	24	36	SCD361-0610-2-2-140HA03-HP132	30421402
6,20	8	79	34	24	36	SCD361-0620-2-2-140HA03-HP132	30421403
6,30	8	79	34	24	36	SCD361-0630-2-2-140HA03-HP132	30421404
6,40	8	79	34	24	36	SCD361-0640-2-2-140HA03-HP132	30421405

ECU-Drill-Steel | Punta elicoidale in metallo duro integrale SCD361 (3xD), adduzione interna del refrigerante

Dimensioni						Forma del codolo HA	
d ₁ m7	d ₂ h6	l ₁	l ₂	l ₃	l ₄	Specifiche	Codice
6,50	8	79	34	24	36	SCD361-0650-2-2-140HA03-HP132	30421406
6,60	8	79	34	24	36	SCD361-0660-2-2-140HA03-HP132	30421407
6,70	8	79	34	24	36	SCD361-0670-2-2-140HA03-HP132	30421408
6,80	8	79	34	24	36	SCD361-0680-2-2-140HA03-HP132	30421409
6,90	8	79	34	24	36	SCD361-0690-2-2-140HA03-HP132	30421410
7,00	8	79	34	24	36	SCD361-0700-2-2-140HA03-HP132	30421411
7,10	8	79	41	29	36	SCD361-0710-2-2-140HA03-HP132	30421412
7,20	8	79	41	29	36	SCD361-0720-2-2-140HA03-HP132	30421413
7,40	8	79	41	29	36	SCD361-0740-2-2-140HA03-HP132	30421415
7,45*	8	79	41	29	36	SCD361-0745-2-2-140HA03-HP132	30421416
7,50	8	79	41	29	36	SCD361-0750-2-2-140HA03-HP132	30421417
7,70	8	79	41	29	36	SCD361-0770-2-2-140HA03-HP132	30421420
7,80	8	79	41	29	36	SCD361-0780-2-2-140HA03-HP132	30421421
7,90	8	79	41	29	36	SCD361-0790-2-2-140HA03-HP132	30421422
8,00	8	79	41	29	36	SCD361-0800-2-2-140HA03-HP132	30421423
8,10	10	89	47	35	40	SCD361-0810-2-2-140HA03-HP132	30421424
8,20	10	89	47	35	40	SCD361-0820-2-2-140HA03-HP132	30421425
8,30	10	89	47	35	40	SCD361-0830-2-2-140HA03-HP132	30421426
8,40	10	89	47	35	40	SCD361-0840-2-2-140HA03-HP132	30421427
8,50	10	89	47	35	40	SCD361-0850-2-2-140HA03-HP132	30421428
8,60	10	89	47	35	40	SCD361-0860-2-2-140HA03-HP132	30421429
8,70	10	89	47	35	40	SCD361-0870-2-2-140HA03-HP132	30421430
8,80	10	89	47	35	40	SCD361-0880-2-2-140HA03-HP132	30421431
8,90	10	89	47	35	40	SCD361-0890-2-2-140HA03-HP132	30421432
9,00	10	89	47	35	40	SCD361-0900-2-2-140HA03-HP132	30421433
9,10	10	89	47	35	40	SCD361-0910-2-2-140HA03-HP132	30421434
9,20	10	89	47	35	40	SCD361-0920-2-2-140HA03-HP132	30421435
9,30*	10	89	47	35	40	SCD361-0930-2-2-140HA03-HP132	30421437
9,35	10	89	47	35	40	SCD361-0935-2-2-140HA03-HP132	30421438
9,40	10	89	47	35	40	SCD361-0940-2-2-140HA03-HP132	30421439
9,50	10	89	47	35	40	SCD361-0950-2-2-140HA03-HP132	30421440
9,60	10	89	47	35	40	SCD361-0960-2-2-140HA03-HP132	30421441
9,80	10	89	47	35	40	SCD361-0980-2-2-140HA03-HP132	30421443
9,90	10	89	47	35	40	SCD361-0990-2-2-140HA03-HP132	30421445
10,00	10	89	47	35	40	SCD361-1000-2-2-140HA03-HP132	30421446
10,10	12	102	55	40	45	SCD361-1010-2-2-140HA03-HP132	30421447
10,20	12	102	55	40	45	SCD361-1020-2-2-140HA03-HP132	30421448
10,30	12	102	55	40	45	SCD361-1030-2-2-140HA03-HP132	30421449
10,40	12	102	55	40	45	SCD361-1040-2-2-140HA03-HP132	30421450
10,50	12	102	55	40	45	SCD361-1050-2-2-140HA03-HP132	30421451
10,60	12	102	55	40	45	SCD361-1060-2-2-140HA03-HP132	30421453
10,70	12	102	55	40	45	SCD361-1070-2-2-140HA03-HP132	30421454
10,80	12	102	55	40	45	SCD361-1080-2-2-140HA03-HP132	30421456
10,90	12	102	55	40	45	SCD361-1090-2-2-140HA03-HP132	30421457
11,00	12	102	55	40	45	SCD361-1100-2-2-140HA03-HP132	30421458
11,10	12	102	55	40	45	SCD361-1110-2-2-140HA03-HP132	30421459
11,20*	12	102	55	40	45	SCD361-1120-2-2-140HA03-HP132	30421460
11,40	12	102	55	40	45	SCD361-1140-2-2-140HA03-HP132	30421463
11,50	12	102	55	40	45	SCD361-1150-2-2-140HA03-HP132	30421464
11,70	12	102	55	40	45	SCD361-1170-2-2-140HA03-HP132	30421466
11,80	12	102	55	40	45	SCD361-1180-2-2-140HA03-HP132	30421467
12,00	12	102	55	40	45	SCD361-1200-2-2-140HA03-HP132	30421469
12,25	14	107	60	43	45	SCD361-1225-2-2-140HA03-HP132	30421470
12,50	14	107	60	43	45	SCD361-1250-2-2-140HA03-HP132	30421471
12,70	14	107	60	43	45	SCD361-1270-2-2-140HA03-HP132	30421472
12,80	14	107	60	43	45	SCD361-1280-2-2-140HA03-HP132	30421473
12,90	14	107	60	43	45	SCD361-1290-2-2-140HA03-HP132	30421474

ECU-Drill-Steel | Punta elicoidale in metallo duro integrale SCD361 (3xD), adduzione interna del refrigerante

Dimensioni						Forma del codolo HA	
d ₁ m7	d ₂ h6	l ₁	l ₂	l ₃	l ₄	Specifiche	Codice
13,00	14	107	60	43	45	SCD361-1300-2-2-140HA03-HP132	30421475
13,10	14	107	60	43	45	SCD361-1310-2-2-140HA03-HP132	30421476
13,20	14	107	60	43	45	SCD361-1320-2-2-140HA03-HP132	30421477
13,50	14	107	60	43	45	SCD361-1350-2-2-140HA03-HP132	30421479
13,80	14	107	60	43	45	SCD361-1380-2-2-140HA03-HP132	30421481
14,00	14	107	60	43	45	SCD361-1400-2-2-140HA03-HP132	30421482
14,20	16	115	65	45	48	SCD361-1420-2-2-140HA03-HP132	30421483
14,50	16	115	65	45	48	SCD361-1450-2-2-140HA03-HP132	30421484
14,80	16	115	65	45	48	SCD361-1480-2-2-140HA03-HP132	30421487
15,00	16	115	65	45	48	SCD361-1500-2-2-140HA03-HP132	30421488
15,10	16	115	65	45	48	SCD361-1510-2-2-140HA03-HP132	30421489
15,25	16	115	65	45	48	SCD361-1525-2-2-140HA03-HP132	30421490
15,30	16	115	65	45	48	SCD361-1530-2-2-140HA03-HP132	30421491
15,50	16	115	65	45	48	SCD361-1550-2-2-140HA03-HP132	30421493
15,80	16	115	65	45	48	SCD361-1580-2-2-140HA03-HP132	30421496
16,00	16	115	65	45	48	SCD361-1600-2-2-140HA03-HP132	30421497
16,50	18	123	73	51	48	SCD361-1650-2-2-140HA03-HP132	30421498
16,80	18	123	73	51	48	SCD361-1680-2-2-140HA03-HP132	30421499
17,00	18	123	73	51	48	SCD361-1700-2-2-140HA03-HP132	30421501
17,50	18	123	73	51	48	SCD361-1750-2-2-140HA03-HP132	30421502
17,80	18	123	73	51	48	SCD361-1780-2-2-140HA03-HP132	30421504
18,00	18	123	73	51	48	SCD361-1800-2-2-140HA03-HP132	30421505
18,50	20	131	79	55	50	SCD361-1850-2-2-140HA03-HP132	30421506
19,00	20	131	79	55	50	SCD361-1900-2-2-140HA03-HP132	30421509
19,80	20	131	79	55	50	SCD361-1980-2-2-140HA03-HP132	30421512
20,00	20	131	79	55	50	SCD361-2000-2-2-140HA03-HP132	30421513

Caratteristiche configurabili



Forma del codolo:
Forma del codolo: HB | HE

**Specifiche:**

SCD361-0430-2-2-140[forma del codolo]03-HP132

Esempio:

SCD361-0430-2-2-140HE03-HP132

Forma del codolo HE

Misure in mm.

* Specifica per la prefabbricazione di fori da maschiare per maschi a filettare.

Per i parametri di lavorazione consigliati, vedere la fine del capitolo.

Versioni speciali e altri rivestimenti disponibili su richiesta.

ECU-Drill-Steel

Punta elicoidale in metallo duro integrale
SCD360 (3xD), adduzione esterna del refrigerante

Versione:

Diametro punta: 3,00 - 20,00 mm
Tolleranza di foratura: \geq IT 9
Materiale da taglio: HP132
Numero di taglienti: 2
Angolo tra taglienti: 140°
Angolo dell'elica: 30°

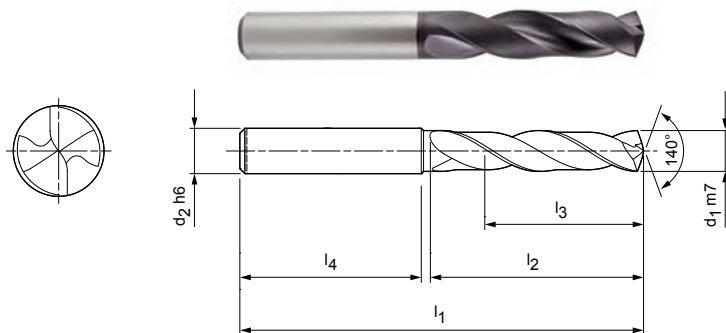

Serie selezionata per il magazzino con forma del codolo HA

Dimensioni						Forma del codolo HA	
d ₁ m7	d ₂ h6	l ₁	l ₂	l ₃	l ₄	Specifiche	Codice
3,00	6	62	20	14	36	SCD360-0300-2-2-140HA03-HP132	30421215
3,10	6	62	20	14	36	SCD360-0310-2-2-140HA03-HP132	30421216
3,20	6	62	20	14	36	SCD360-0320-2-2-140HA03-HP132	30421217
3,30	6	62	20	14	36	SCD360-0330-2-2-140HA03-HP132	30421218
3,40	6	62	20	14	36	SCD360-0340-2-2-140HA03-HP132	30421219
3,50	6	62	20	14	36	SCD360-0350-2-2-140HA03-HP132	30421220
3,60	6	62	20	14	36	SCD360-0360-2-2-140HA03-HP132	30421221
3,70*	6	62	20	14	36	SCD360-0370-2-2-140HA03-HP132	30421222
3,80	6	66	24	17	36	SCD360-0380-2-2-140HA03-HP132	30421223
3,90	6	66	24	17	36	SCD360-0390-2-2-140HA03-HP132	30421224
4,00	6	66	24	17	36	SCD360-0400-2-2-140HA03-HP132	30421225
4,02	6	66	24	17	36	SCD360-0402-2-2-140HA03-HP132	30421226
4,10	6	66	24	17	36	SCD360-0410-2-2-140HA03-HP132	30421227
4,20	6	66	24	17	36	SCD360-0420-2-2-140HA03-HP132	30421228
4,30	6	66	24	17	36	SCD360-0430-2-2-140HA03-HP132	30421229
4,40	6	66	24	17	36	SCD360-0440-2-2-140HA03-HP132	30421230
4,50	6	66	24	17	36	SCD360-0450-2-2-140HA03-HP132	30421231
4,60	6	66	24	17	36	SCD360-0460-2-2-140HA03-HP132	30421232
4,65*	6	66	24	17	36	SCD360-0465-2-2-140HA03-HP132	30421233
4,70	6	66	24	17	36	SCD360-0470-2-2-140HA03-HP132	30421234
4,80	6	66	28	20	36	SCD360-0480-2-2-140HA03-HP132	30421235
4,90	6	66	28	20	36	SCD360-0490-2-2-140HA03-HP132	30421236
5,00	6	66	28	20	36	SCD360-0500-2-2-140HA03-HP132	30421237
5,10	6	66	28	20	36	SCD360-0510-2-2-140HA03-HP132	30421238
5,20	6	66	28	20	36	SCD360-0520-2-2-140HA03-HP132	30421240
5,30	6	66	28	20	36	SCD360-0530-2-2-140HA03-HP132	30421241
5,40	6	66	28	20	36	SCD360-0540-2-2-140HA03-HP132	30421242
5,50	6	66	28	20	36	SCD360-0550-2-2-140HA03-HP132	30421243
5,55*	6	66	28	20	36	SCD360-0555-2-2-140HA03-HP132	30421244
5,60	6	66	28	20	36	SCD360-0560-2-2-140HA03-HP132	30421245
5,70	6	66	28	20	36	SCD360-0570-2-2-140HA03-HP132	30421246
5,80	6	66	28	20	36	SCD360-0580-2-2-140HA03-HP132	30421247
5,90	6	66	28	20	36	SCD360-0590-2-2-140HA03-HP132	30421248
6,00	6	66	28	20	36	SCD360-0600-2-2-140HA03-HP132	30421249
6,10	8	79	34	24	36	SCD360-0610-2-2-140HA03-HP132	30421250

ECU-Drill-Steel | Punta elicoidale in metallo duro integrale SCD360 (3xD), adduzione esterna del refrigerante

Dimensioni						Forma del codolo HA	
d ₁ m7	d ₂ h6	l ₁	l ₂	l ₃	l ₄	Specifiche	Codice
6,20	8	79	34	24	36	SCD360-0620-2-2-140HA03-HP132	30421251
6,30	8	79	34	24	36	SCD360-0630-2-2-140HA03-HP132	30421252
6,40	8	79	34	24	36	SCD360-0640-2-2-140HA03-HP132	30421253
6,50	8	79	34	24	36	SCD360-0650-2-2-140HA03-HP132	30421254
6,60	8	79	34	24	36	SCD360-0660-2-2-140HA03-HP132	30421255
6,70	8	79	34	24	36	SCD360-0670-2-2-140HA03-HP132	30421256
6,80	8	79	34	24	36	SCD360-0680-2-2-140HA03-HP132	30421257
6,90	8	79	34	24	36	SCD360-0690-2-2-140HA03-HP132	30421258
7,00	8	79	34	24	36	SCD360-0700-2-2-140HA03-HP132	30421259
7,10	8	79	41	29	36	SCD360-0710-2-2-140HA03-HP132	30421260
7,20	8	79	41	29	36	SCD360-0720-2-2-140HA03-HP132	30421261
7,30	8	79	41	29	36	SCD360-0730-2-2-140HA03-HP132	30421262
7,40	8	79	41	29	36	SCD360-0740-2-2-140HA03-HP132	30421263
7,50	8	79	41	29	36	SCD360-0750-2-2-140HA03-HP132	30421264
7,60	8	79	41	29	36	SCD360-0760-2-2-140HA03-HP132	30421266
7,70	8	79	41	29	36	SCD360-0770-2-2-140HA03-HP132	30421267
7,80	8	79	41	29	36	SCD360-0780-2-2-140HA03-HP132	30421268
7,90	8	79	41	29	36	SCD360-0790-2-2-140HA03-HP132	30421269
8,00	8	79	41	29	36	SCD360-0800-2-2-140HA03-HP132	30421270
8,10	10	89	47	35	40	SCD360-0810-2-2-140HA03-HP132	30421271
8,20	10	89	47	35	40	SCD360-0820-2-2-140HA03-HP132	30421272
8,30	10	89	47	35	40	SCD360-0830-2-2-140HA03-HP132	30421273
8,40	10	89	47	35	40	SCD360-0840-2-2-140HA03-HP132	30421274
8,50	10	89	47	35	40	SCD360-0850-2-2-140HA03-HP132	30421275
8,60	10	89	47	35	40	SCD360-0860-2-2-140HA03-HP132	30421276
8,70	10	89	47	35	40	SCD360-0870-2-2-140HA03-HP132	30421277
8,80	10	89	47	35	40	SCD360-0880-2-2-140HA03-HP132	30421278
8,90	10	89	47	35	40	SCD360-0890-2-2-140HA03-HP132	30421279
9,00	10	89	47	35	40	SCD360-0900-2-2-140HA03-HP132	30421280
9,10	10	89	47	35	40	SCD360-0910-2-2-140HA03-HP132	30421281
9,20	10	89	47	35	40	SCD360-0920-2-2-140HA03-HP132	30421282
9,30*	10	89	47	35	40	SCD360-0930-2-2-140HA03-HP132	30421284
9,40	10	89	47	35	40	SCD360-0940-2-2-140HA03-HP132	30421285
9,50	10	89	47	35	40	SCD360-0950-2-2-140HA03-HP132	30421286
9,60	10	89	47	35	40	SCD360-0960-2-2-140HA03-HP132	30421287
9,70	10	89	47	35	40	SCD360-0970-2-2-140HA03-HP132	30421288
9,80	10	89	47	35	40	SCD360-0980-2-2-140HA03-HP132	30421289
9,90	10	89	47	35	40	SCD360-0990-2-2-140HA03-HP132	30421290
10,00	10	89	47	35	40	SCD360-1000-2-2-140HA03-HP132	30421291
10,10	12	102	55	40	45	SCD360-1010-2-2-140HA03-HP132	30421292
10,20	12	102	55	40	45	SCD360-1020-2-2-140HA03-HP132	30421293
10,30	12	102	55	40	45	SCD360-1030-2-2-140HA03-HP132	30421294
10,40	12	102	55	40	45	SCD360-1040-2-2-140HA03-HP132	30421295
10,50	12	102	55	40	45	SCD360-1050-2-2-140HA03-HP132	30421296
10,60	12	102	55	40	45	SCD360-1060-2-2-140HA03-HP132	30421297
10,70	12	102	55	40	45	SCD360-1070-2-2-140HA03-HP132	30421298
10,80	12	102	55	40	45	SCD360-1080-2-2-140HA03-HP132	30421300
10,90	12	102	55	40	45	SCD360-1090-2-2-140HA03-HP132	30421301
11,00	12	102	55	40	45	SCD360-1100-2-2-140HA03-HP132	30421302
11,10	12	102	55	40	45	SCD360-1110-2-2-140HA03-HP132	30421303
11,20*	12	102	55	40	45	SCD360-1120-2-2-140HA03-HP132	30421304
11,30	12	102	55	40	45	SCD360-1130-2-2-140HA03-HP132	30421305
11,40	12	102	55	40	45	SCD360-1140-2-2-140HA03-HP132	30421306
11,50	12	102	55	40	45	SCD360-1150-2-2-140HA03-HP132	30421307
11,60	12	102	55	40	45	SCD360-1160-2-2-140HA03-HP132	30421308
11,70	12	102	55	40	45	SCD360-1170-2-2-140HA03-HP132	30421309
11,80	12	102	55	40	45	SCD360-1180-2-2-140HA03-HP132	30421310

Prosegue alla pagina seguente.

ECU-Drill-Steel | Punta elicoidale in metallo duro integrale SCD360 (3xD), adduzione esterna del refrigerante

Dimensioni						Forma del codolo HA	
d ₁ m7	d ₂ h6	l ₁	l ₂	l ₃	l ₄	Specifiche	Codice
11,90	12	102	55	40	45	SCD360-1190-2-2-140HA03-HP132	30421312
12,00	12	102	55	40	45	SCD360-1200-2-2-140HA03-HP132	30421313
12,20	14	107	60	43	45	SCD360-1220-2-2-140HA03-HP132	30569112
12,25	14	107	60	43	45	SCD360-1225-2-2-140HA03-HP132	30421314
12,50	14	107	60	43	45	SCD360-1250-2-2-140HA03-HP132	30421316
12,70	14	107	60	43	45	SCD360-1270-2-2-140HA03-HP132	30421317
12,80	14	107	60	43	45	SCD360-1280-2-2-140HA03-HP132	30421318
13,00	14	107	60	43	45	SCD360-1300-2-2-140HA03-HP132	30421320
13,30	14	107	60	43	45	SCD360-1330-2-2-140HA03-HP132	30421323
13,50	14	107	60	43	45	SCD360-1350-2-2-140HA03-HP132	30421324
13,70	14	107	60	43	45	SCD360-1370-2-2-140HA03-HP132	30421325
13,80	14	107	60	43	45	SCD360-1380-2-2-140HA03-HP132	30421326
14,00	14	107	60	43	45	SCD360-1400-2-2-140HA03-HP132	30421327
14,20	16	115	65	45	48	SCD360-1420-2-2-140HA03-HP132	30421328
14,50	16	115	65	45	48	SCD360-1450-2-2-140HA03-HP132	30421330
14,70	16	115	65	45	48	SCD360-1470-2-2-140HA03-HP132	30421331
15,00	16	115	65	45	48	SCD360-1500-2-2-140HA03-HP132	30421333
15,25	16	115	65	45	48	SCD360-1525-2-2-140HA03-HP132	30421335
15,30	16	115	65	45	48	SCD360-1530-2-2-140HA03-HP132	30421336
15,50	16	115	65	45	48	SCD360-1550-2-2-140HA03-HP132	30421337
15,80	16	115	65	45	48	SCD360-1580-2-2-140HA03-HP132	30421339
16,00	16	115	65	45	48	SCD360-1600-2-2-140HA03-HP132	30421340
16,50	18	123	73	51	48	SCD360-1650-2-2-140HA03-HP132	30421341
16,80	18	123	73	51	48	SCD360-1680-2-2-140HA03-HP132	30421342
17,00	18	123	73	51	48	SCD360-1700-2-2-140HA03-HP132	30421343
17,50	18	123	73	51	48	SCD360-1750-2-2-140HA03-HP132	30421344
17,80	18	123	73	51	48	SCD360-1780-2-2-140HA03-HP132	30421345
18,00	18	123	73	51	48	SCD360-1800-2-2-140HA03-HP132	30421346
18,50	20	131	79	55	50	SCD360-1850-2-2-140HA03-HP132	30421347
19,00	20	131	79	55	50	SCD360-1900-2-2-140HA03-HP132	30421349
19,50	20	131	79	55	50	SCD360-1950-2-2-140HA03-HP132	30421350
19,80	20	131	79	55	50	SCD360-1980-2-2-140HA03-HP132	30421351
20,00	20	131	79	55	50	SCD360-2000-2-2-140HA03-HP132	30421352

Caratteristiche configurabili



Forma del codolo:
Forma del codolo: HB | HE

**Specifiche:**

SCD360-0430-2-2-140[forma del codolo]05-HP132

Esempio:

SCD360-0430-2-2-140HE05-HP132

Forma del codolo HE

Misure in mm.

* Specifica per la prefabbricazione di fori da maschiare per maschi a filettare.

Per i parametri di lavorazione consigliati, vedere la fine del capitolo.

Versioni speciali e altri rivestimenti disponibili su richiesta.

ECU-Drill-Steel

Punta elicoidale in metallo duro integrale
SCD361 (5xD), adduzione interna del refrigerante

Versione:

Diametro punta: 3,00 - 20,00 mm
Tolleranza di foratura: \geq IT 9
Materiale da taglio: HP132
Numero di taglienti: 2
Angolo tra taglienti: 140°
Angolo dell'elica: 30°

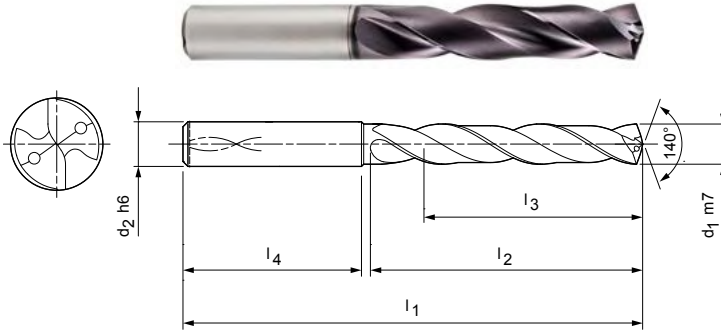

Serie selezionata per il magazzino con forma del codolo HA

Dimensioni						Forma del codolo HA	
d ₁ m7	d ₂ h6	l ₁	l ₂	l ₃	l ₄	Specifiche	Codice
3,00	6	66	28	23	36	SCD361-0300-2-2-140HA05-HP132	30421524
3,10	6	66	28	23	36	SCD361-0310-2-2-140HA05-HP132	30421525
3,20	6	66	28	23	36	SCD361-0320-2-2-140HA05-HP132	30421526
3,30	6	66	28	23	36	SCD361-0330-2-2-140HA05-HP132	30421528
3,40	6	66	28	23	36	SCD361-0340-2-2-140HA05-HP132	30421529
3,50	6	66	28	23	36	SCD361-0350-2-2-140HA05-HP132	30421530
3,60	6	66	28	23	36	SCD361-0360-2-2-140HA05-HP132	30421531
3,70*	6	66	28	23	36	SCD361-0370-2-2-140HA05-HP132	30421532
3,80	6	74	36	29	36	SCD361-0380-2-2-140HA05-HP132	30421533
3,90	6	74	36	29	36	SCD361-0390-2-2-140HA05-HP132	30421534
4,00	6	74	36	29	36	SCD361-0400-2-2-140HA05-HP132	30421535
4,10	6	74	36	29	36	SCD361-0410-2-2-140HA05-HP132	30421536
4,20	6	74	36	29	36	SCD361-0420-2-2-140HA05-HP132	30421537
4,30	6	74	36	29	36	SCD361-0430-2-2-140HA05-HP132	30421539
4,40	6	74	36	29	36	SCD361-0440-2-2-140HA05-HP132	30421540
4,50	6	74	36	29	36	SCD361-0450-2-2-140HA05-HP132	30421541
4,60	6	74	36	29	36	SCD361-0460-2-2-140HA05-HP132	30421542
4,65*	6	74	36	29	36	SCD361-0465-2-2-140HA05-HP132	30421543
4,70	6	74	36	29	36	SCD361-0470-2-2-140HA05-HP132	30421544
4,80	6	82	44	35	36	SCD361-0480-2-2-140HA05-HP132	30421545
4,90	6	82	44	35	36	SCD361-0490-2-2-140HA05-HP132	30421546
5,00	6	82	44	35	36	SCD361-0500-2-2-140HA05-HP132	30421548
5,10	6	82	44	35	36	SCD361-0510-2-2-140HA05-HP132	30421550
5,20	6	82	44	35	36	SCD361-0520-2-2-140HA05-HP132	30421551
5,30	6	82	44	35	36	SCD361-0530-2-2-140HA05-HP132	30421552
5,40	6	82	44	35	36	SCD361-0540-2-2-140HA05-HP132	30421553
5,50	6	82	44	35	36	SCD361-0550-2-2-140HA05-HP132	30421554
5,55*	6	82	44	35	36	SCD361-0555-2-2-140HA05-HP132	30421555
5,60	6	82	44	35	36	SCD361-0560-2-2-140HA05-HP132	30421556
5,70	6	82	44	35	36	SCD361-0570-2-2-140HA05-HP132	30421557
5,80	6	82	44	35	36	SCD361-0580-2-2-140HA05-HP132	30421559
5,90	6	82	44	35	36	SCD361-0590-2-2-140HA05-HP132	30421560
6,00	6	82	44	35	36	SCD361-0600-2-2-140HA05-HP132	30421561
6,10	8	91	53	43	36	SCD361-0610-2-2-140HA05-HP132	30421562
6,20	8	91	53	43	36	SCD361-0620-2-2-140HA05-HP132	30421563

ECU-Drill-Steel | Punta elicoidale in metallo duro integrale SCD361 (5xD), adduzione interna del refrigerante

Dimensioni						Forma del codolo HA	
d ₁ m7	d ₂ h6	l ₁	l ₂	l ₃	l ₄	Specifiche	Codice
6,30	8	91	53	43	36	SCD361-0630-2-2-140HA05-HP132	30421564
6,40	8	91	53	43	36	SCD361-0640-2-2-140HA05-HP132	30421565
6,50	8	91	53	43	36	SCD361-0650-2-2-140HA05-HP132	30421566
6,60	8	91	53	43	36	SCD361-0660-2-2-140HA05-HP132	30421567
6,70	8	91	53	43	36	SCD361-0670-2-2-140HA05-HP132	30421568
6,80	8	91	53	43	36	SCD361-0680-2-2-140HA05-HP132	30421569
6,90	8	91	53	43	36	SCD361-0690-2-2-140HA05-HP132	30421570
7,00	8	91	53	43	36	SCD361-0700-2-2-140HA05-HP132	30421571
7,10	8	91	53	43	36	SCD361-0710-2-2-140HA05-HP132	30421572
7,20	8	91	53	43	36	SCD361-0720-2-2-140HA05-HP132	30421573
7,30	8	91	53	43	36	SCD361-0730-2-2-140HA05-HP132	30421574
7,40	8	91	53	43	36	SCD361-0740-2-2-140HA05-HP132	30421575
7,45*	8	91	53	43	36	SCD361-0745-2-2-140HA05-HP132	30421576
7,50	8	91	53	43	36	SCD361-0750-2-2-140HA05-HP132	30421577
7,60	8	91	53	43	36	SCD361-0760-2-2-140HA05-HP132	30421579
7,70	8	91	53	43	36	SCD361-0770-2-2-140HA05-HP132	30421580
7,80	8	91	53	43	36	SCD361-0780-2-2-140HA05-HP132	30421581
7,90	8	91	53	43	36	SCD361-0790-2-2-140HA05-HP132	30421582
8,00	8	91	53	43	36	SCD361-0800-2-2-140HA05-HP132	30421583
8,10	10	103	61	49	40	SCD361-0810-2-2-140HA05-HP132	30421584
8,20	10	103	61	49	40	SCD361-0820-2-2-140HA05-HP132	30421585
8,30	10	103	61	49	40	SCD361-0830-2-2-140HA05-HP132	30421586
8,40	10	103	61	49	40	SCD361-0840-2-2-140HA05-HP132	30421587
8,50	10	103	61	49	40	SCD361-0850-2-2-140HA05-HP132	30421588
8,60	10	103	61	49	40	SCD361-0860-2-2-140HA05-HP132	30421589
8,70	10	103	61	49	40	SCD361-0870-2-2-140HA05-HP132	30421590
8,80	10	103	61	49	40	SCD361-0880-2-2-140HA05-HP132	30421591
8,90	10	103	61	49	40	SCD361-0890-2-2-140HA05-HP132	30421592
9,00	10	103	61	49	40	SCD361-0900-2-2-140HA05-HP132	30421593
9,10	10	103	61	49	40	SCD361-0910-2-2-140HA05-HP132	30421594
9,20	10	103	61	49	40	SCD361-0920-2-2-140HA05-HP132	30421595
9,30*	10	103	61	49	40	SCD361-0930-2-2-140HA05-HP132	30421597
9,35	10	103	61	49	40	SCD361-0935-2-2-140HA05-HP132	30421598
9,40	10	103	61	49	40	SCD361-0940-2-2-140HA05-HP132	30421599
9,50	10	103	61	49	40	SCD361-0950-2-2-140HA05-HP132	30421600
9,60	10	103	61	49	40	SCD361-0960-2-2-140HA05-HP132	30421601
9,70	10	103	61	49	40	SCD361-0970-2-2-140HA05-HP132	30421602
9,80	10	103	61	49	40	SCD361-0980-2-2-140HA05-HP132	30421603
9,90	10	103	61	49	40	SCD361-0990-2-2-140HA05-HP132	30421604
10,00	10	103	61	49	40	SCD361-1000-2-2-140HA05-HP132	30421605
10,10	12	118	71	56	45	SCD361-1010-2-2-140HA05-HP132	30421606
10,20	12	118	71	56	45	SCD361-1020-2-2-140HA05-HP132	30421607
10,30	12	118	71	56	45	SCD361-1030-2-2-140HA05-HP132	30421608
10,40	12	118	71	56	45	SCD361-1040-2-2-140HA05-HP132	30421609
10,50	12	118	71	56	45	SCD361-1050-2-2-140HA05-HP132	30421610
10,60	12	118	71	56	45	SCD361-1060-2-2-140HA05-HP132	30421612
10,70	12	118	71	56	45	SCD361-1070-2-2-140HA05-HP132	30421613
10,80	12	118	71	56	45	SCD361-1080-2-2-140HA05-HP132	30421615
10,90	12	118	71	56	45	SCD361-1090-2-2-140HA05-HP132	30421616
11,00	12	118	71	56	45	SCD361-1100-2-2-140HA05-HP132	30421617
11,10	12	118	71	56	45	SCD361-1110-2-2-140HA05-HP132	30421618
11,20*	12	118	71	56	45	SCD361-1120-2-2-140HA05-HP132	30421619
11,25	12	118	71	56	45	SCD361-1125-2-2-140HA05-HP132	30421620
11,30	12	118	71	56	45	SCD361-1130-2-2-140HA05-HP132	30421621
11,40	12	118	71	56	45	SCD361-1140-2-2-140HA05-HP132	30421622
11,50	12	118	71	56	45	SCD361-1150-2-2-140HA05-HP132	30421623
11,60	12	118	71	56	45	SCD361-1160-2-2-140HA05-HP132	30421624

ECU-Drill-Steel | Punta elicoidale in metallo duro integrale SCD361 (5xD), adduzione interna del refrigerante

Dimensioni						Forma del codolo HA	
d ₁ m7	d ₂ h6	l ₁	l ₂	l ₃	l ₄	Specifiche	Codice
11,70	12	118	71	56	45	SCD361-1170-2-2-140HA05-HP132	30421625
11,80	12	118	71	56	45	SCD361-1180-2-2-140HA05-HP132	30421626
11,90	12	118	71	56	45	SCD361-1190-2-2-140HA05-HP132	30421628
12,00	12	118	71	56	45	SCD361-1200-2-2-140HA05-HP132	30421629
12,20	14	124	77	60	45	SCD361-1220-2-2-140HA05-HP132	30569175
12,25	14	124	77	60	45	SCD361-1225-2-2-140HA05-HP132	30421630
12,50	14	124	77	60	45	SCD361-1250-2-2-140HA05-HP132	30421632
12,70	14	124	77	60	45	SCD361-1270-2-2-140HA05-HP132	30421633
12,80	14	124	77	60	45	SCD361-1280-2-2-140HA05-HP132	30421634
12,90	14	124	77	60	45	SCD361-1290-2-2-140HA05-HP132	30421635
13,00	14	124	77	60	45	SCD361-1300-2-2-140HA05-HP132	30421636
13,10	14	124	77	60	45	SCD361-1310-2-2-140HA05-HP132	30421637
13,20	14	124	77	60	45	SCD361-1320-2-2-140HA05-HP132	30421638
13,50	14	124	77	60	45	SCD361-1350-2-2-140HA05-HP132	30421640
13,70	14	124	77	60	45	SCD361-1370-2-2-140HA05-HP132	30421641
13,80	14	124	77	60	45	SCD361-1380-2-2-140HA05-HP132	30421642
14,00	14	124	77	60	45	SCD361-1400-2-2-140HA05-HP132	30421643
14,20	16	133	83	63	48	SCD361-1420-2-2-140HA05-HP132	30421644
14,50	16	133	83	63	48	SCD361-1450-2-2-140HA05-HP132	30421645
14,70	16	133	83	63	48	SCD361-1470-2-2-140HA05-HP132	30421646
14,80	16	133	83	63	48	SCD361-1480-2-2-140HA05-HP132	30421647
15,00	16	133	83	63	48	SCD361-1500-2-2-140HA05-HP132	30421648
15,10	16	133	83	63	48	SCD361-1510-2-2-140HA05-HP132	30421649
15,25	16	133	83	63	48	SCD361-1525-2-2-140HA05-HP132	30421650
15,30	16	133	83	63	48	SCD361-1530-2-2-140HA05-HP132	30421651
15,50	16	133	83	63	48	SCD361-1550-2-2-140HA05-HP132	30421652
15,70	16	133	83	63	48	SCD361-1570-2-2-140HA05-HP132	30421654
15,80	16	133	83	63	48	SCD361-1580-2-2-140HA05-HP132	30421655
16,00	16	133	83	63	48	SCD361-1600-2-2-140HA05-HP132	30421656
16,50	18	143	93	71	48	SCD361-1650-2-2-140HA05-HP132	30421657
16,80	18	143	93	71	48	SCD361-1680-2-2-140HA05-HP132	30421658
17,00	18	143	93	71	48	SCD361-1700-2-2-140HA05-HP132	30421660
17,50	18	143	93	71	48	SCD361-1750-2-2-140HA05-HP132	30421661
17,80	18	143	93	71	48	SCD361-1780-2-2-140HA05-HP132	30421663
18,00	18	143	93	71	48	SCD361-1800-2-2-140HA05-HP132	30421664
18,50	20	153	101	77	50	SCD361-1850-2-2-140HA05-HP132	30421665
18,80	20	153	101	77	50	SCD361-1880-2-2-140HA05-HP132	30421666
19,00	20	153	101	77	50	SCD361-1900-2-2-140HA05-HP132	30421668
19,50	20	153	101	77	50	SCD361-1950-2-2-140HA05-HP132	30421669
19,80	20	153	101	77	50	SCD361-1980-2-2-140HA05-HP132	30421671
20,00	20	153	101	77	50	SCD361-2000-2-2-140HA05-HP132	30421672

Prosegue alla pagina seguente.

ECU-Drill-Steel | Punta elicoidale in metallo duro integrale SCD361 (5xD), adduzione interna del refrigerante**Caratteristiche configurabili**

Forma del codolo:
Forma del codolo: HB | HE

**Specifiche:**

SCD361-0430-2-2-140[forma del codolo]05-HP132

Esempio:

SCD361-0430-2-2-140HE05-HP132

Forma del codolo HE

Misure in mm.

* Specifica per la prefabbricazione di fori da maschiare per maschi a filettare.

Per i parametri di lavorazione consigliati, vedere la fine del capitolo.

Versioni speciali e altri rivestimenti disponibili su richiesta.

ECU-Drill-Steel

Punta elicoidale in metallo duro integrale
SCD360 (5xD), adduzione esterna del refrigerante

Versione:

Diametro punta: 3,00 - 20,00 mm
Tolleranza di foratura: \geq IT 9
Materiale da taglio: HP132
Numero di taglienti: 2
Angolo tra taglienti: 140°
Angolo dell'elica: 30°

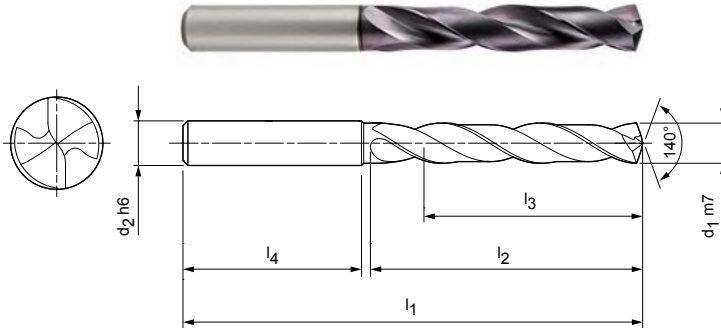

Serie selezionata per il magazzino con forma del codolo HA

Dimensioni						Forma del codolo HA	
d ₁ m7	d ₂ h6	l ₁	l ₂	l ₃	l ₄	Specifiche	Codice
3,00	6	66	28	23	36	SCD360-0300-2-2-140HA05-HP132	30568692
3,10	6	66	28	23	36	SCD360-0310-2-2-140HA05-HP132	30568693
3,20	6	66	28	23	36	SCD360-0320-2-2-140HA05-HP132	30568694
3,30	6	66	28	23	36	SCD360-0330-2-2-140HA05-HP132	30568695
3,40	6	66	28	23	36	SCD360-0340-2-2-140HA05-HP132	30568696
3,50	6	66	28	23	36	SCD360-0350-2-2-140HA05-HP132	30568697
3,60	6	66	28	23	36	SCD360-0360-2-2-140HA05-HP132	30568698
3,70*	6	66	28	23	36	SCD360-0370-2-2-140HA05-HP132	30568699
3,80	6	74	36	29	36	SCD360-0380-2-2-140HA05-HP132	30568700
3,90	6	74	36	29	36	SCD360-0390-2-2-140HA05-HP132	30568701
4,00	6	74	36	29	36	SCD360-0400-2-2-140HA05-HP132	30568702
4,10	6	74	36	29	36	SCD360-0410-2-2-140HA05-HP132	30568703
4,20	6	74	36	29	36	SCD360-0420-2-2-140HA05-HP132	30568704
4,30	6	74	36	29	36	SCD360-0430-2-2-140HA05-HP132	30568705
4,40	6	74	36	29	36	SCD360-0440-2-2-140HA05-HP132	30568706
4,50	6	74	36	29	36	SCD360-0450-2-2-140HA05-HP132	30568707
4,60	6	74	36	29	36	SCD360-0460-2-2-140HA05-HP132	30568708
4,65*	6	74	36	29	36	SCD360-0465-2-2-140HA05-HP132	30568709
4,70	6	74	36	29	36	SCD360-0470-2-2-140HA05-HP132	30568710
4,80	6	82	44	35	36	SCD360-0480-2-2-140HA05-HP132	30568711
4,90	6	82	44	35	36	SCD360-0490-2-2-140HA05-HP132	30568712
5,00	6	82	44	35	36	SCD360-0500-2-2-140HA05-HP132	30568713
5,10	6	82	44	35	36	SCD360-0510-2-2-140HA05-HP132	30568714
5,20	6	82	44	35	36	SCD360-0520-2-2-140HA05-HP132	30568715
5,30	6	82	44	35	36	SCD360-0530-2-2-140HA05-HP132	30568716
5,40	6	82	44	35	36	SCD360-0540-2-2-140HA05-HP132	30568717
5,50	6	82	44	35	36	SCD360-0550-2-2-140HA05-HP132	30568718
5,55*	6	82	44	35	36	SCD360-0555-2-2-140HA05-HP132	30568719
5,60	6	82	44	35	36	SCD360-0560-2-2-140HA05-HP132	30568720
5,70	6	82	44	35	36	SCD360-0570-2-2-140HA05-HP132	30568721
5,80	6	82	44	35	36	SCD360-0580-2-2-140HA05-HP132	30568722
5,90	6	82	44	35	36	SCD360-0590-2-2-140HA05-HP132	30568723
6,00	6	82	44	35	36	SCD360-0600-2-2-140HA05-HP132	30568724
6,10	8	91	53	43	36	SCD360-0610-2-2-140HA05-HP132	30568725
6,20	8	91	53	43	36	SCD360-0620-2-2-140HA05-HP132	30568726

ECU-Drill-Steel | Punta elicoidale in metallo duro integrale SCD360 (5xD), adduzione esterna del refrigerante

Dimensioni						Forma del codolo HA	
d ₁ m7	d ₂ h6	l ₁	l ₂	l ₃	l ₄	Specifiche	Codice
6,30	8	91	53	43	36	SCD360-0630-2-2-140HA05-HP132	30568727
6,40	8	91	53	43	36	SCD360-0640-2-2-140HA05-HP132	30568728
6,50	8	91	53	43	36	SCD360-0650-2-2-140HA05-HP132	30568729
6,60	8	91	53	43	36	SCD360-0660-2-2-140HA05-HP132	30568730
6,70	8	91	53	43	36	SCD360-0670-2-2-140HA05-HP132	30568731
6,80	8	91	53	43	36	SCD360-0680-2-2-140HA05-HP132	30568732
6,90	8	91	53	43	36	SCD360-0690-2-2-140HA05-HP132	30568733
7,00	8	91	53	43	36	SCD360-0700-2-2-140HA05-HP132	30568734
7,10	8	91	53	43	36	SCD360-0710-2-2-140HA05-HP132	30568735
7,20	8	91	53	43	36	SCD360-0720-2-2-140HA05-HP132	30568736
7,30	8	91	53	43	36	SCD360-0730-2-2-140HA05-HP132	30568737
7,40	8	91	53	43	36	SCD360-0740-2-2-140HA05-HP132	30568738
7,50	8	91	53	43	36	SCD360-0750-2-2-140HA05-HP132	30568740
7,60	8	91	53	43	36	SCD360-0760-2-2-140HA05-HP132	30568741
7,70	8	91	53	43	36	SCD360-0770-2-2-140HA05-HP132	30568742
7,80	8	91	53	43	36	SCD360-0780-2-2-140HA05-HP132	30568743
7,90	8	91	53	43	36	SCD360-0790-2-2-140HA05-HP132	30568744
8,00	8	91	53	43	36	SCD360-0800-2-2-140HA05-HP132	30568745
8,10	10	103	61	49	40	SCD360-0810-2-2-140HA05-HP132	30568746
8,20	10	103	61	49	40	SCD360-0820-2-2-140HA05-HP132	30568747
8,30	10	103	61	49	40	SCD360-0830-2-2-140HA05-HP132	30568748
8,40	10	103	61	49	40	SCD360-0840-2-2-140HA05-HP132	30568749
8,50	10	103	61	49	40	SCD360-0850-2-2-140HA05-HP132	30568750
8,60	10	103	61	49	40	SCD360-0860-2-2-140HA05-HP132	30568751
8,70	10	103	61	49	40	SCD360-0870-2-2-140HA05-HP132	30568752
8,80	10	103	61	49	40	SCD360-0880-2-2-140HA05-HP132	30568753
8,90	10	103	61	49	40	SCD360-0890-2-2-140HA05-HP132	30568754
9,00	10	103	61	49	40	SCD360-0900-2-2-140HA05-HP132	30568755
9,10	10	103	61	49	40	SCD360-0910-2-2-140HA05-HP132	30568756
9,20	10	103	61	49	40	SCD360-0920-2-2-140HA05-HP132	30568757
9,30*	10	103	61	49	40	SCD360-0930-2-2-140HA05-HP132	30568758
9,40	10	103	61	49	40	SCD360-0940-2-2-140HA05-HP132	30568759
9,50	10	103	61	49	40	SCD360-0950-2-2-140HA05-HP132	30568760
9,60	10	103	61	49	40	SCD360-0960-2-2-140HA05-HP132	30568761
9,70	10	103	61	49	40	SCD360-0970-2-2-140HA05-HP132	30568762
9,80	10	103	61	49	40	SCD360-0980-2-2-140HA05-HP132	30568763
9,90	10	103	61	49	40	SCD360-0990-2-2-140HA05-HP132	30568764
10,00	10	103	61	49	40	SCD360-1000-2-2-140HA05-HP132	30568765
10,10	12	118	71	56	45	SCD360-1010-2-2-140HA05-HP132	30568766
10,20	12	118	71	56	45	SCD360-1020-2-2-140HA05-HP132	30568767
10,30	12	118	71	56	45	SCD360-1030-2-2-140HA05-HP132	30568768
10,40	12	118	71	56	45	SCD360-1040-2-2-140HA05-HP132	30568769
10,50	12	118	71	56	45	SCD360-1050-2-2-140HA05-HP132	30568770
10,60	12	118	71	56	45	SCD360-1060-2-2-140HA05-HP132	30568771
10,80	12	118	71	56	45	SCD360-1080-2-2-140HA05-HP132	30568773
11,00	12	118	71	56	45	SCD360-1100-2-2-140HA05-HP132	30568775
11,10	12	118	71	56	45	SCD360-1110-2-2-140HA05-HP132	30568776
11,20*	12	118	71	56	45	SCD360-1120-2-2-140HA05-HP132	30568777
11,30	12	118	71	56	45	SCD360-1130-2-2-140HA05-HP132	30568778
11,40	12	118	71	56	45	SCD360-1140-2-2-140HA05-HP132	30568779
11,50	12	118	71	56	45	SCD360-1150-2-2-140HA05-HP132	30568780
11,60	12	118	71	56	45	SCD360-1160-2-2-140HA05-HP132	30568781
11,70	12	118	71	56	45	SCD360-1170-2-2-140HA05-HP132	30568782
11,80	12	118	71	56	45	SCD360-1180-2-2-140HA05-HP132	30568783
11,90	12	118	71	56	45	SCD360-1190-2-2-140HA05-HP132	30568784
12,00	12	118	71	56	45	SCD360-1200-2-2-140HA05-HP132	30568785
12,20	14	124	77	60	45	SCD360-1220-2-2-140HA05-HP132	30568786

ECU-Drill-Steel | Punta elicoidale in metallo duro integrale SCD360 (5xD), adduzione esterna del refrigerante

Dimensioni						Forma del codolo HA	
d ₁ m7	d ₂ h6	l ₁	l ₂	l ₃	l ₄	Specifiche	Codice
12,50	14	124	77	60	45	SCD360-1250-2-2-140HA05-HP132	30568787
12,70	14	124	77	60	45	SCD360-1270-2-2-140HA05-HP132	30568788
12,80	14	124	77	60	45	SCD360-1280-2-2-140HA05-HP132	30568789
13,00	14	124	77	60	45	SCD360-1300-2-2-140HA05-HP132	30568790
13,10	14	124	77	60	45	SCD360-1310-2-2-140HA05-HP132	30569190
13,50	14	124	77	60	45	SCD360-1350-2-2-140HA05-HP132	30568792
13,70	14	124	77	60	45	SCD360-1370-2-2-140HA05-HP132	30568793
13,80	14	124	77	60	45	SCD360-1380-2-2-140HA05-HP132	30568794
14,00	14	124	77	60	45	SCD360-1400-2-2-140HA05-HP132	30568795
14,20	16	133	83	63	48	SCD360-1420-2-2-140HA05-HP132	30568796
14,50	16	133	83	63	48	SCD360-1450-2-2-140HA05-HP132	30568797
14,70	16	133	83	63	48	SCD360-1470-2-2-140HA05-HP132	30568798
14,80	16	133	83	63	48	SCD360-1480-2-2-140HA05-HP132	30568799
15,00	16	133	83	63	48	SCD360-1500-2-2-140HA05-HP132	30568800
15,50	16	133	83	63	48	SCD360-1550-2-2-140HA05-HP132	30568801
15,70	16	133	83	63	48	SCD360-1570-2-2-140HA05-HP132	30568802
15,80	16	133	83	63	48	SCD360-1580-2-2-140HA05-HP132	30568803
16,00	16	133	83	63	48	SCD360-1600-2-2-140HA05-HP132	30568804
16,50	18	143	93	71	48	SCD360-1650-2-2-140HA05-HP132	30568805
17,00	18	143	93	71	48	SCD360-1700-2-2-140HA05-HP132	30568807
17,50	18	143	93	71	48	SCD360-1750-2-2-140HA05-HP132	30568808
18,00	18	143	93	71	48	SCD360-1800-2-2-140HA05-HP132	30568810
18,50	20	153	101	77	50	SCD360-1850-2-2-140HA05-HP132	30568811
18,80	20	153	101	77	50	SCD360-1880-2-2-140HA05-HP132	30568812
19,00	20	153	101	77	50	SCD360-1900-2-2-140HA05-HP132	30568813
19,80	20	153	101	77	50	SCD360-1980-2-2-140HA05-HP132	30568815
20,00	20	153	101	77	50	SCD360-2000-2-2-140HA05-HP132	30568816

Caratteristiche configurabili



Forma del codolo:
Forma del codolo: HB | HE

**Specifiche:**

SCD360-0430-2-2-140[forma del codolo]05-HP132

Esempio:

SCD360-0430-2-2-140HE05-HP132

Forma del codolo HE

Misure in mm.

* Specifica per la prefabbricazione di fori da maschiare per maschi a filettare.

Per i parametri di lavorazione consigliati, vedere la fine del capitolo.

Versioni speciali e altri rivestimenti disponibili su richiesta.

ECU-Drill-Steel

Punta elicoidale in metallo duro integrale
SCD361 (8xD), adduzione interna del refrigerante

Versione:

Diametro punta: 3,00 - 20,00 mm
Tolleranza di foratura: \geq IT 9
Materiale da taglio: HP132
Numero di taglienti: 2
Angolo tra taglienti: 135°
Angolo dell'elica: 30°

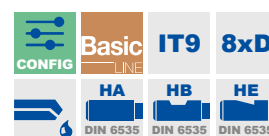
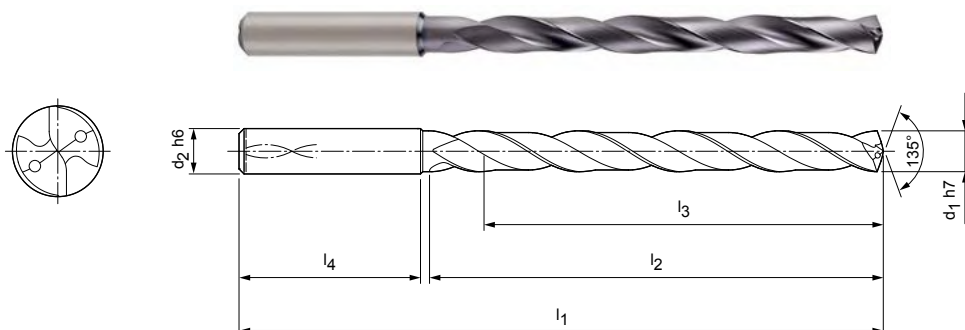

Serie selezionata per il magazzino con forma del codolo HA

Dimensioni						Forma del codolo HA	
d ₁ h7	d ₂ h6	l ₁	l ₂	l ₃	l ₄	Specifiche	Codice
3,00	6	72	34	29	36	SCD361-0300-2-2-135HA08-HP132	30677713
3,10	6	72	34	29	36	SCD361-0310-2-2-135HA08-HP132	30677714
3,20	6	72	34	29	36	SCD361-0320-2-2-135HA08-HP132	30677715
3,30	6	72	34	29	36	SCD361-0330-2-2-135HA08-HP132	30677716
3,40	6	72	34	29	36	SCD361-0340-2-2-135HA08-HP132	30677717
3,50	6	72	34	29	36	SCD361-0350-2-2-135HA08-HP132	30677718
3,60	6	72	34	29	36	SCD361-0360-2-2-135HA08-HP132	30677719
3,70	6	72	34	29	36	SCD361-0370-2-2-135HA08-HP132	30677720
3,80	6	81	43	36	36	SCD361-0380-2-2-135HA08-HP132	30677721
3,90	6	81	43	36	36	SCD361-0390-2-2-135HA08-HP132	30677722
4,00	6	81	43	36	36	SCD361-0400-2-2-135HA08-HP132	30677723
4,10	6	81	43	36	36	SCD361-0410-2-2-135HA08-HP132	30677724
4,20	6	81	43	36	36	SCD361-0420-2-2-135HA08-HP132	30677725
4,30	6	81	43	36	36	SCD361-0430-2-2-135HA08-HP132	30677726
4,40	6	81	43	36	36	SCD361-0440-2-2-135HA08-HP132	30677727
4,50	6	81	43	36	36	SCD361-0450-2-2-135HA08-HP132	30677728
4,60	6	81	43	36	36	SCD361-0460-2-2-135HA08-HP132	30677729
4,70	6	81	43	36	36	SCD361-0470-2-2-135HA08-HP132	30677730
4,80	6	95	57	48	36	SCD361-0480-2-2-135HA08-HP132	30677731
4,90	6	95	57	48	36	SCD361-0490-2-2-135HA08-HP132	30677732
5,00	6	95	57	48	36	SCD361-0500-2-2-135HA08-HP132	30677733
5,10	6	95	57	48	36	SCD361-0510-2-2-135HA08-HP132	30677734
5,20	6	95	57	48	36	SCD361-0520-2-2-135HA08-HP132	30677735
5,30	6	95	57	48	36	SCD361-0530-2-2-135HA08-HP132	30677736
5,50	6	95	57	48	36	SCD361-0550-2-2-135HA08-HP132	30677738
5,70	6	95	57	48	36	SCD361-0570-2-2-135HA08-HP132	30677740
5,80	6	95	57	48	36	SCD361-0580-2-2-135HA08-HP132	30677741
5,90	6	95	57	48	36	SCD361-0590-2-2-135HA08-HP132	30677742
6,00	6	95	57	48	36	SCD361-0600-2-2-135HA08-HP132	30677743
6,10	8	114	76	64	36	SCD361-0610-2-2-135HA08-HP132	30677744
6,20	8	114	76	64	36	SCD361-0620-2-2-135HA08-HP132	30677745
6,30	8	114	76	64	36	SCD361-0630-2-2-135HA08-HP132	30677746
6,50	8	114	76	64	36	SCD361-0650-2-2-135HA08-HP132	30677748
6,60	8	114	76	64	36	SCD361-0660-2-2-135HA08-HP132	30677749
6,70	8	114	76	64	36	SCD361-0670-2-2-135HA08-HP132	30677751

ECU-Drill-Steel | Punta elicoidale in metallo duro integrale SCD361 (8xD), adduzione interna del refrigerante

Dimensioni						Forma del codolo HA	
d ₁ h7	d ₂ h6	l ₁	l ₂	l ₃	l ₄	Specifiche	Codice
6,80	8	114	76	64	36	SCD361-0680-2-2-135HA08-HP132	30677752
6,90	8	114	76	64	36	SCD361-0690-2-2-135HA08-HP132	30677753
7,00	8	114	76	64	36	SCD361-0700-2-2-135HA08-HP132	30677754
7,10	8	114	76	64	36	SCD361-0710-2-2-135HA08-HP132	30677755
7,40	8	114	76	64	36	SCD361-0740-2-2-135HA08-HP132	30677758
7,50	8	114	76	64	36	SCD361-0750-2-2-135HA08-HP132	30677759
7,70	8	114	76	64	36	SCD361-0770-2-2-135HA08-HP132	30677761
7,80	8	114	76	64	36	SCD361-0780-2-2-135HA08-HP132	30677762
7,90	8	114	76	64	36	SCD361-0790-2-2-135HA08-HP132	30677763
8,00	8	114	76	64	36	SCD361-0800-2-2-135HA08-HP132	30677764
8,10	10	142	95	80	40	SCD361-0810-2-2-135HA08-HP132	30677765
8,20	10	142	95	80	40	SCD361-0820-2-2-135HA08-HP132	30677766
8,30	10	142	95	80	40	SCD361-0830-2-2-135HA08-HP132	30677767
8,50	10	142	95	80	40	SCD361-0850-2-2-135HA08-HP132	30677769
8,60	10	142	95	80	40	SCD361-0860-2-2-135HA08-HP132	30677770
8,70	10	142	95	80	40	SCD361-0870-2-2-135HA08-HP132	30677772
8,80	10	142	95	80	40	SCD361-0880-2-2-135HA08-HP132	30677773
9,00	10	142	95	80	40	SCD361-0900-2-2-135HA08-HP132	30677775
9,10	10	142	95	80	40	SCD361-0910-2-2-135HA08-HP132	30677776
9,20	10	142	95	80	40	SCD361-0920-2-2-135HA08-HP132	30677777
9,30	10	142	95	80	40	SCD361-0930-2-2-135HA08-HP132	30677778
9,40	10	142	95	80	40	SCD431-0940-2-2-135HA08-HP765	30550363
9,50	10	142	95	80	40	SCD361-0950-2-2-135HA08-HP132	30677780
9,70	10	142	95	80	40	SCD361-0970-2-2-135HA08-HP132	30677782
9,80	10	142	95	80	40	SCD361-0980-2-2-135HA08-HP132	30677783
9,90	10	142	95	80	40	SCD361-0990-2-2-135HA08-HP132	30677784
10,00	10	142	95	80	40	SCD361-1000-2-2-135HA08-HP132	30677785
10,20	12	162	114	96	45	SCD361-1020-2-2-135HA08-HP132	30677787
10,30	12	162	114	96	45	SCD361-1030-2-2-135HA08-HP132	30677788
10,50	12	162	114	96	45	SCD361-1050-2-2-135HA08-HP132	30677790
10,80	12	162	114	96	45	SCD361-1080-2-2-135HA08-HP132	30677793
11,00	12	162	114	96	45	SCD361-1100-2-2-135HA08-HP132	30677795
11,20	12	162	114	96	45	SCD361-1120-2-2-135HA08-HP132	30677797
11,50	12	162	114	96	45	SCD361-1150-2-2-135HA08-HP132	30677800
11,70	12	162	114	96	45	SCD361-1170-2-2-135HA08-HP132	30677802
11,80	12	162	114	96	45	SCD361-1180-2-2-135HA08-HP132	30677803
12,00	12	162	114	96	45	SCD361-1200-2-2-135HA08-HP132	30677805
12,20	14	178	133	112	45	SCD361-1220-2-2-135HA08-HP132	30677806
12,50	14	178	133	112	45	SCD361-1250-2-2-135HA08-HP132	30677807
12,80	14	178	133	112	45	SCD361-1280-2-2-135HA08-HP132	30677808
13,00	14	178	133	112	45	SCD361-1300-2-2-135HA08-HP132	30677809
13,50	14	178	133	112	45	SCD361-1350-2-2-135HA08-HP132	30677811
13,80	14	178	133	112	45	SCD361-1380-2-2-135HA08-HP132	30677812
14,00	14	178	133	112	45	SCD361-1400-2-2-135HA08-HP132	30677813
14,50	16	203	152	128	48	SCD361-1450-2-2-135HA08-HP132	30677815
15,00	16	203	152	128	48	SCD361-1500-2-2-135HA08-HP132	30677817
15,50	16	203	152	128	48	SCD361-1550-2-2-135HA08-HP132	30677818
15,80	16	203	152	128	48	SCD361-1580-2-2-135HA08-HP132	30677819
16,00	16	203	152	128	48	SCD361-1600-2-2-135HA08-HP132	30677820
16,50	18	222	171	144	48	SCD361-1650-2-2-135HA08-HP132	30677821
17,00	18	222	171	144	48	SCD361-1700-2-2-135HA08-HP132	30677822
17,50	18	222	171	144	48	SCD361-1750-2-2-135HA08-HP132	30677823
18,00	18	222	171	144	48	SCD361-1800-2-2-135HA08-HP132	30677824
18,50	20	243	190	160	50	SCD361-1850-2-2-135HA08-HP132	30677825
19,00	20	243	190	160	50	SCD361-1900-2-2-135HA08-HP132	30677826
20,00	20	243	190	160	50	SCD361-2000-2-2-135HA08-HP132	30677828

ECU-Drill-Steel | Punta elicoidale in metallo duro integrale SCD361 (8xD), adduzione interna del refrigerante**Caratteristiche configurabili**

Forma del codolo:
Forma del codolo: HB | HE

**Specifiche:**

SCD361-0430-2-2-140[forma del codolo]08-HP132

Esempio:

SCD361-0430-2-2-140HE08-HP132

Forma del codolo HE

ECU-Drill-Steel

Punta elicoidale in metallo duro integrale
SCD361 (12xD), adduzione interna del refrigerante

Versione:

Diametro punta: 3,00 - 18,00 mm
Tolleranza di foratura: \geq IT 9
Materiale da taglio: HP132
Numero di taglienti: 2
Angolo tra taglienti: 135°
Angolo dell'elica: 30°

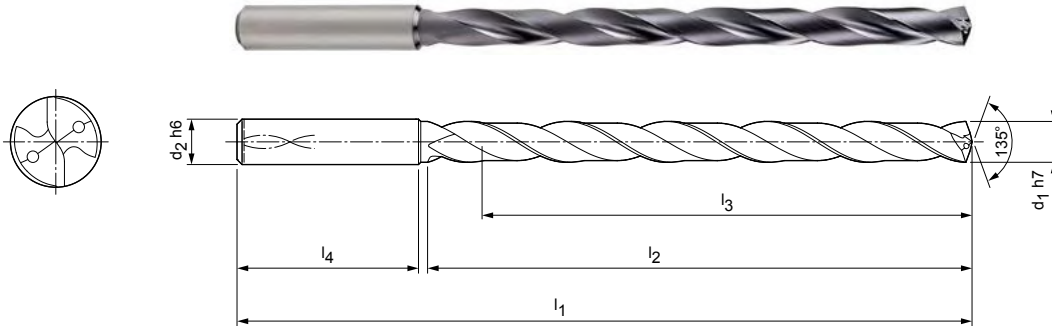

Serie selezionata per il magazzino con forma del codolo HA

Dimensioni						Forma del codolo HA	
d ₁ h7	d ₂ h6	l ₁	l ₂	l ₃	l ₄	Specifiche	Codice
3,00	6	92	54	48	36	SCD361-0300-2-2-135HA12-HP132	30677829
3,10	6	92	54	48	36	SCD361-0310-2-2-135HA12-HP132	30677830
3,20	6	92	54	48	36	SCD361-0320-2-2-135HA12-HP132	30677831
3,30	6	92	54	48	36	SCD361-0330-2-2-135HA12-HP132	30677832
3,40	6	92	54	48	36	SCD361-0340-2-2-135HA12-HP132	30677833
3,50	6	92	54	48	36	SCD361-0350-2-2-135HA12-HP132	30677834
3,60	6	92	54	48	36	SCD361-0360-2-2-135HA12-HP132	30677835
3,70	6	92	54	48	36	SCD361-0370-2-2-135HA12-HP132	30677836
3,80	6	102	64	58	36	SCD361-0380-2-2-135HA12-HP132	30677837
3,90	6	102	64	58	36	SCD361-0390-2-2-135HA12-HP132	30677838
4,00	6	102	64	58	36	SCD361-0400-2-2-135HA12-HP132	30677839
4,10	6	102	64	58	36	SCD361-0410-2-2-135HA12-HP132	30677840
4,20	6	102	64	58	36	SCD361-0420-2-2-135HA12-HP132	30677841
4,30	6	102	64	58	36	SCD361-0430-2-2-135HA12-HP132	30677842
4,40	6	102	64	58	36	SCD361-0440-2-2-135HA12-HP132	30677843
4,50	6	102	64	58	36	SCD361-0450-2-2-135HA12-HP132	30677844
4,60	6	102	64	58	36	SCD361-0460-2-2-135HA12-HP132	30677845
4,70	6	102	64	58	36	SCD361-0470-2-2-135HA12-HP132	30677846
4,80	6	116	78	70	36	SCD361-0480-2-2-135HA12-HP132	30677847
4,90	6	116	78	70	36	SCD361-0490-2-2-135HA12-HP132	30677848
5,00	6	116	78	70	36	SCD361-0500-2-2-135HA12-HP132	30677849
5,10	6	116	78	70	36	SCD361-0510-2-2-135HA12-HP132	30677850
5,20	6	116	78	70	36	SCD361-0520-2-2-135HA12-HP132	30677851
5,50	6	116	78	70	36	SCD361-0550-2-2-135HA12-HP132	30677853
5,80	6	116	78	70	36	SCD361-0580-2-2-135HA12-HP132	30677854
6,00	6	116	78	70	36	SCD361-0600-2-2-135HA12-HP132	30677856
6,30	8	146	108	94	36	SCD361-0630-2-2-135HA12-HP132	30677859
6,50	8	146	108	94	36	SCD361-0650-2-2-135HA12-HP132	30677860
6,60	8	146	108	94	36	SCD361-0660-2-2-135HA12-HP132	30677861
6,80	8	146	108	94	36	SCD361-0680-2-2-135HA12-HP132	30677862
7,00	8	146	108	94	36	SCD361-0700-2-2-135HA12-HP132	30677863
7,40	8	146	108	94	36	SCD361-0740-2-2-135HA12-HP132	30677864
7,50	8	146	108	94	36	SCD361-0750-2-2-135HA12-HP132	30677865
7,80	8	146	108	94	36	SCD361-0780-2-2-135HA12-HP132	30677867
8,00	8	146	108	94	36	SCD361-0800-2-2-135HA12-HP132	30677869

ECU-Drill-Steel | Punta elicoidale in metallo duro integrale SCD361 (12xD), adduzione interna del refrigerante

Dimensioni						Forma del codolo HA	
d ₁ h7	d ₂ h6	l ₁	l ₂	l ₃	l ₄	Specifiche	Codice
8,10	10	162	120	110	40	SCD361-0810-2-2-135HA12-HP132	30677870
8,20	10	162	120	110	40	SCD361-0820-2-2-135HA12-HP132	30677871
8,50	10	162	120	110	40	SCD361-0850-2-2-135HA12-HP132	30677874
9,00	10	162	120	110	40	SCD361-0900-2-2-135HA12-HP132	30677878
9,30	10	162	120	110	40	SCD361-0930-2-2-135HA12-HP132	30677881
9,50	10	162	120	110	40	SCD361-0950-2-2-135HA12-HP132	30677883
9,80	10	162	120	110	40	SCD361-0980-2-2-135HA12-HP132	30677885
10,00	10	162	120	110	40	SCD361-1000-2-2-135HA12-HP132	30677887
10,20	12	204	156	142	45	SCD361-1020-2-2-135HA12-HP132	30677888
10,50	12	204	156	142	45	SCD361-1050-2-2-135HA12-HP132	30677889
11,00	12	204	156	142	45	SCD361-1100-2-2-135HA12-HP132	30677891
11,50	12	204	156	142	45	SCD361-1150-2-2-135HA12-HP132	30677893
11,80	12	204	156	142	45	SCD361-1180-2-2-135HA12-HP132	30677894
12,00	12	204	156	142	45	SCD361-1200-2-2-135HA12-HP132	30677895
12,50	14	230	182	166	45	SCD361-1250-2-2-135HA12-HP132	30677896
13,00	14	230	182	166	45	SCD361-1300-2-2-135HA12-HP132	30677897
13,50	14	230	182	166	45	SCD361-1350-2-2-135HA12-HP132	30677899
14,00	14	230	182	166	45	SCD361-1400-2-2-135HA12-HP132	30677900
15,00	16	260	208	192	48	SCD361-1500-2-2-135HA12-HP132	30677903
16,00	16	260	208	192	48	SCD361-1600-2-2-135HA12-HP132	30677906
17,00	18	285	234	216	48	SCD361-1700-2-2-135HA12-HP132	30677908
17,50	18	285	234	216	48	SCD361-1750-2-2-135HA12-HP132	30677909
18,00	18	285	234	216	48	SCD361-1800-2-2-135HA12-HP132	30677910

Caratteristiche configurabili



Forma del codolo:
Forma del codolo: HB | HE

**Specifiche:**

SCD361-0430-2-2-140[forma del codolo]12-HP132

Esempio:

SCD361-0430-2-2-140HE12-HP132

Forma del codolo HE

Misure in mm.

Per i parametri di lavorazione consigliati, vedere la fine del capitolo.

Versioni speciali e altri rivestimenti disponibili su richiesta.

MEGA-Drill-Inox

Punta elicoidale in metallo duro integrale
SCD120 (3xD), adduzione esterna del refrigerante

Versione:

Diametro punta: 2,00 – 20,00 mm
Tolleranza di foratura: \geq IT 9
Materiale da taglio: HP835
Numero di taglienti: 2
Numero margini di guida: 2
Angolo tra taglienti: 140°
Angolo dell'elica: 30°

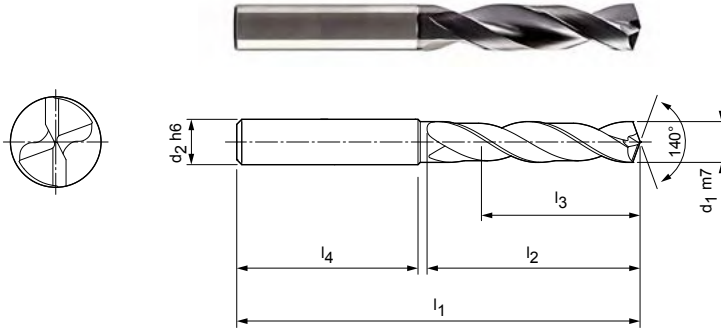

Serie selezionata per il magazzino con forma del codolo HA

Dimensioni						Forma del codolo HA	
d_1 m7	d_2 h6	l_1	l_2	l_3	l_4	Specifiche	Codice
2,00	6	58	16	11	36	SCD120-0200-2-2-140HA03-HP835	30444703
2,10	6	58	16	11	36	SCD120-0210-2-2-140HA03-HP835	30453589
2,20	6	58	16	11	36	SCD120-0220-2-2-140HA03-HP835	30453826
2,30	6	58	16	11	36	SCD120-0230-2-2-140HA03-HP835	30453515
2,33	6	58	16	11	36	SCD120-0233-2-2-140HA03-HP835	30453605
2,40	6	58	16	11	36	SCD120-0240-2-2-140HA03-HP835	30444776
2,43	6	58	16	11	36	SCD120-0243-2-2-140HA03-HP835	30453606
2,50	6	58	16	11	36	SCD120-0250-2-2-140HA03-HP835	30451313
2,55	6	62	22	14	36	SCD120-0255-2-2-140HA03-HP835	30453607
2,60	6	58	16	11	36	SCD120-0260-2-2-140HA03-HP835	30453541
2,62	6	58	16	11	36	SCD120-0262-2-2-140HA03-HP835	30453608
2,70	6	58	16	11	36	SCD120-0270-2-2-140HA03-HP835	30453525
2,80	6	58	16	11	36	SCD120-0280-2-2-140HA03-HP835	30453502
2,90	6	58	16	11	36	SCD120-0290-2-2-140HA03-HP835	30453546
3,00	6	62	22	14	36	SCD120-0300-2-2-140HA03-HP835	30390310
3,10	6	62	22	14	36	SCD120-0310-2-2-140HA03-HP835	30390311
3,15	6	62	22	14	36	SCD120-0315-2-2-140HA03-HP835	30453609
3,20	6	62	22	14	36	SCD120-0320-2-2-140HA03-HP835	30390312
3,22	6	62	22	14	36	SCD120-0322-2-2-140HA03-HP835	30453610
3,25	6	62	22	14	36	SCD120-0325-2-2-140HA03-HP835	30453611
3,30	6	62	22	14	36	SCD120-0330-2-2-140HA03-HP835	30390313
3,40	6	62	22	14	36	SCD120-0340-2-2-140HA03-HP835	30390314
3,50	6	62	22	14	36	SCD120-0350-2-2-140HA03-HP835	30390315
3,60	6	62	22	14	36	SCD120-0360-2-2-140HA03-HP835	30390316
3,70	6	62	22	14	36	SCD120-0370-2-2-140HA03-HP835	30390317
3,80	6	66	26	17	36	SCD120-0380-2-2-140HA03-HP835	30390318
3,90	6	66	26	17	36	SCD120-0390-2-2-140HA03-HP835	30390319
4,00	6	66	26	17	36	SCD120-0400-2-2-140HA03-HP835	30390320
4,05	6	66	26	17	36	SCD120-0405-2-2-140HA03-HP835	30445425
4,10	6	66	26	17	36	SCD120-0410-2-2-140HA03-HP835	30390321
4,20	6	66	26	17	36	SCD120-0420-2-2-140HA03-HP835	30390322
4,30	6	66	26	17	36	SCD120-0430-2-2-140HA03-HP835	30390323
4,35	6	66	26	17	36	SCD120-0435-2-2-140HA03-HP835	30453613
4,40	6	66	26	17	36	SCD120-0440-2-2-140HA03-HP835	30390324
4,50	6	66	26	17	36	SCD120-0450-2-2-140HA03-HP835	30390325

MEGA-Drill-Inox | Punta elicoidale in metallo duro integrale SCD120 (3xD), adduzione esterna del refrigerante

Dimensioni						Forma del codolo HA	
d ₁ m7	d ₂ h6	l ₁	l ₂	l ₃	l ₄	Specifiche	Codice
4,60	6	66	26	17	36	SCD120-0460-2-2-140HA03-HP835	30390326
4,65	6	66	26	17	36	SCD120-0465-2-2-140HA03-HP835	30452080
4,70	6	66	26	17	36	SCD120-0470-2-2-140HA03-HP835	30390327
4,80	6	66	30	20	36	SCD120-0480-2-2-140HA03-HP835	30390328
4,90	6	66	30	20	36	SCD120-0490-2-2-140HA03-HP835	30390329
5,00	6	66	30	20	36	SCD120-0500-2-2-140HA03-HP835	30390330
5,03	6	66	30	20	36	SCD120-0503-2-2-140HA03-HP835	30453912
5,10	6	66	30	20	36	SCD120-0510-2-2-140HA03-HP835	30390331
5,20	6	66	30	20	36	SCD120-0520-2-2-140HA03-HP835	30390332
5,30	6	66	30	20	36	SCD120-0530-2-2-140HA03-HP835	30390333
5,40	6	66	30	20	36	SCD120-0540-2-2-140HA03-HP835	30390334
5,50	6	66	30	20	36	SCD120-0550-2-2-140HA03-HP835	30390335
5,55	6	66	30	20	36	SCD120-0555-2-2-140HA03-HP835	30452081
5,60	6	66	30	20	36	SCD120-0560-2-2-140HA03-HP835	30390336
5,70	6	66	30	20	36	SCD120-0570-2-2-140HA03-HP835	30390337
5,80	6	66	30	20	36	SCD120-0580-2-2-140HA03-HP835	30390338
5,90	6	66	30	20	36	SCD120-0590-2-2-140HA03-HP835	30390339
6,00	6	66	30	20	36	SCD120-0600-2-2-140HA03-HP835	30390340
6,10	8	79	38	24	36	SCD120-0610-2-2-140HA03-HP835	30390341
6,20	8	79	38	24	36	SCD120-0620-2-2-140HA03-HP835	30390342
6,30	8	79	38	24	36	SCD120-0630-2-2-140HA03-HP835	30390343
6,40	8	79	38	24	36	SCD120-0640-2-2-140HA03-HP835	30390344
6,50	8	79	38	24	36	SCD120-0650-2-2-140HA03-HP835	30390345
6,60	8	79	38	24	36	SCD120-0660-2-2-140HA03-HP835	30390346
6,70	8	79	38	24	36	SCD120-0670-2-2-140HA03-HP835	30390347
6,80	8	79	38	24	36	SCD120-0680-2-2-140HA03-HP835	30390348
6,90	8	79	38	24	36	SCD120-0690-2-2-140HA03-HP835	30390349
7,00	8	79	38	24	36	SCD120-0700-2-2-140HA03-HP835	30390350
7,20	8	79	42	29	36	SCD120-0720-2-2-140HA03-HP835	30390352
7,40	8	79	42	29	36	SCD120-0740-2-2-140HA03-HP835	30390354
7,45	8	79	42	29	36	SCD120-0745-2-2-140HA03-HP835	30453616
7,50	8	79	42	29	36	SCD120-0750-2-2-140HA03-HP835	30390355
7,70	8	79	42	29	36	SCD120-0770-2-2-140HA03-HP835	30390357
7,80	8	79	42	29	36	SCD120-0780-2-2-140HA03-HP835	30390358
7,90	8	79	42	29	36	SCD120-0790-2-2-140HA03-HP835	30390359
8,00	8	79	42	29	36	SCD120-0800-2-2-140HA03-HP835	30390360
8,10	10	89	49	35	40	SCD120-0810-2-2-140HA03-HP835	30390361
8,20	10	89	49	35	40	SCD120-0820-2-2-140HA03-HP835	30390362
8,30	10	89	49	35	40	SCD120-0830-2-2-140HA03-HP835	30390363
8,40	10	89	49	35	40	SCD120-0840-2-2-140HA03-HP835	30390364
8,50	10	89	49	35	40	SCD120-0850-2-2-140HA03-HP835	30390365
8,60	10	89	49	35	40	SCD120-0860-2-2-140HA03-HP835	30390366
8,70	10	89	49	35	40	SCD120-0870-2-2-140HA03-HP835	30390367
8,80	10	89	49	35	40	SCD120-0880-2-2-140HA03-HP835	30390368
8,90	10	89	49	35	40	SCD120-0890-2-2-140HA03-HP835	30390369
9,00	10	89	49	35	40	SCD120-0900-2-2-140HA03-HP835	30390370
9,10	10	89	49	35	40	SCD120-0910-2-2-140HA03-HP835	30390371
9,50	10	89	49	35	40	SCD120-0950-2-2-140HA03-HP835	30390375
9,80	10	89	49	35	40	SCD120-0980-2-2-140HA03-HP835	30390378
9,90	10	89	49	35	40	SCD120-0990-2-2-140HA03-HP835	30390379
10,00	10	89	49	35	40	SCD120-1000-2-2-140HA03-HP835	30390380
10,10	12	102	56	40	45	SCD120-1010-2-2-140HA03-HP835	30390381
10,20	12	102	56	40	45	SCD120-1020-2-2-140HA03-HP835	30390382
10,30	12	102	56	40	45	SCD120-1030-2-2-140HA03-HP835	30390383
10,50	12	102	56	40	45	SCD120-1050-2-2-140HA03-HP835	30390385
11,00	12	102	56	40	45	SCD120-1100-2-2-140HA03-HP835	30390390
11,50	12	102	56	40	45	SCD120-1150-2-2-140HA03-HP835	30390395

MEGA-Drill-Inox | Punta elicoidale in metallo duro integrale SCD120 (3xD), adduzione esterna del refrigerante

Dimensioni						Forma del codolo HA	
d ₁ m7	d ₂ h6	l ₁	l ₂	l ₃	l ₄	Specifiche	Codice
11,80	12	102	56	40	45	SCD120-1180-2-2-140HA03-HP835	30390398
12,00	12	102	56	40	45	SCD120-1200-2-2-140HA03-HP835	30390400
12,15	14	107	61	43	45	SCD120-1215-2-2-140HA03-HP835	30453623
12,50	14	107	61	43	45	SCD120-1250-2-2-140HA03-HP835	30390401
12,80	14	107	61	43	45	SCD120-1280-2-2-140HA03-HP835	30445978
13,00	14	107	61	43	45	SCD120-1300-2-2-140HA03-HP835	30390402
13,80	14	107	61	43	45	SCD120-1380-2-2-140HA03-HP835	30445979
14,00	14	107	61	43	45	SCD120-1400-2-2-140HA03-HP835	30390404
15,00	16	115	65	45	48	SCD120-1500-2-2-140HA03-HP835	30390406
16,00	16	115	65	45	48	SCD120-1600-2-2-140HA03-HP835	30390408
17,00	18	123	73	51	48	SCD120-1700-2-2-140HA03-HP835	30390410
18,00	18	123	73	51	48	SCD120-1800-2-2-140HA03-HP835	30390412
19,00	20	131	79	55	50	SCD120-1900-2-2-140HA03-HP835	30390414

Caratteristiche configurabili

**Diametro:**

Diametro a libera scelta a passi da 0,01 mm

**Forma del codolo:**

Forma del codolo: HB | HE

Specifiche:

SCD120-[diametro]-2-2-140[forma del codolo]03-HP835

Dimensioni serie configurabile

d ₁ min.	d ₁ max.	d ₂ h6	l ₁	l ₂	l ₃	l ₄
3,00	3,70	6	62	22	14	36
3,71	4,70	6	66	26	17	36
4,71	6,00	6	66	30	20	36
6,01	7,00	8	79	38	24	36
7,01	8,00	8	79	42	29	36
8,01	10,00	10	89	49	35	40
10,01	12,00	12	102	56	40	45
12,01	14,00	14	107	61	43	45
14,01	16,00	16	115	65	45	48
16,01	18,00	18	123	73	51	48
18,01	20,00	20	131	79	55	50

Esempio:

SCD120-0431-2-2-140HE03-HP835

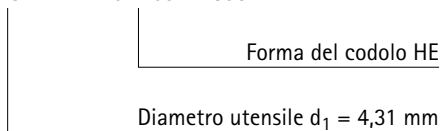

Misure in mm.

Per i parametri di lavorazione consigliati, vedere la fine del capitolo.

Versioni speciali e altri rivestimenti disponibili su richiesta.

MEGA-Drill-Inox

Punta elicoidale in metallo duro integrale
SCD121 (3xD), adduzione interna del refrigerante

Versione:

Diametro punta: 3,00 – 20,00 mm
Tolleranza di foratura: \geq IT 9
Materiale da taglio: HP835
Numero di taglienti: 2
Numero margini di guida: 2
Angolo tra taglienti: 140°
Angolo dell'elica: 30°

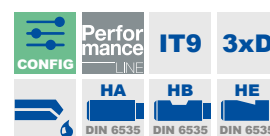
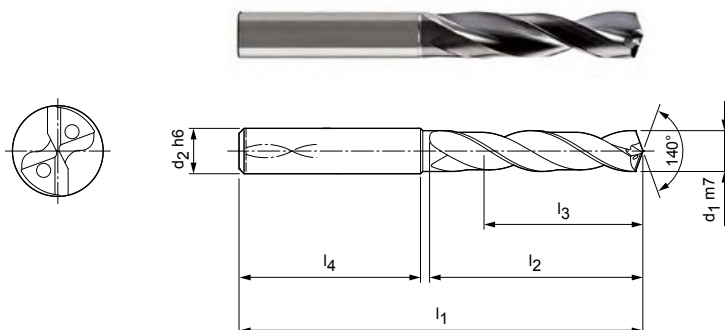
Serie selezionata per il magazzino con forma del codolo HA

Dimensioni						Forma del codolo HA	
d ₁ m7	d ₂ h6	l ₁	l ₂	l ₃	l ₄	Specifiche	Codice
3,00	6	62	22	14	36	SCD121-0300-2-2-140HA03-HP835	30390523
3,05	6	62	22	14	36	SCD121-0305-2-2-140HA03-HP835	30445910
3,15	6	62	22	14	36	SCD121-0315-2-2-140HA03-HP835	30453629
3,20	6	62	22	14	36	SCD121-0320-2-2-140HA03-HP835	30390525
3,25	6	62	22	14	36	SCD121-0325-2-2-140HA03-HP835	30453631
3,30	6	62	22	14	36	SCD121-0330-2-2-140HA03-HP835	30390526
3,40	6	62	22	14	36	SCD121-0340-2-2-140HA03-HP835	30390527
3,50	6	62	22	14	36	SCD121-0350-2-2-140HA03-HP835	30390528
3,60	6	62	22	14	36	SCD121-0360-2-2-140HA03-HP835	30390529
3,70	6	62	22	14	36	SCD121-0370-2-2-140HA03-HP835	30390530
3,80	6	66	26	17	36	SCD121-0380-2-2-140HA03-HP835	30390531
3,90	6	66	26	17	36	SCD121-0390-2-2-140HA03-HP835	30390532
4,00	6	66	26	17	36	SCD121-0400-2-2-140HA03-HP835	30390533
4,10	6	66	26	17	36	SCD121-0410-2-2-140HA03-HP835	30390534
4,20	6	66	26	17	36	SCD121-0420-2-2-140HA03-HP835	30390535
4,30	6	66	26	17	36	SCD121-0430-2-2-140HA03-HP835	30390536
4,35	6	66	26	17	36	SCD121-0435-2-2-140HA03-HP835	30453633
4,40	6	66	26	17	36	SCD121-0440-2-2-140HA03-HP835	30390537
4,50	6	66	26	17	36	SCD121-0450-2-2-140HA03-HP835	30390538
4,65	6	66	26	17	36	SCD121-0465-2-2-140HA03-HP835	30438861
4,70	6	66	26	17	36	SCD121-0470-2-2-140HA03-HP835	30390540
4,80	6	66	30	20	36	SCD121-0480-2-2-140HA03-HP835	30390541
5,00	6	66	30	20	36	SCD121-0500-2-2-140HA03-HP835	30390543
5,10	6	66	30	20	36	SCD121-0510-2-2-140HA03-HP835	30390544
5,20	6	66	30	20	36	SCD121-0520-2-2-140HA03-HP835	30390545
5,30	6	66	30	20	36	SCD121-0530-2-2-140HA03-HP835	30390546
5,40	6	66	30	20	36	SCD121-0540-2-2-140HA03-HP835	30390547
5,50	6	66	30	20	36	SCD121-0550-2-2-140HA03-HP835	30390548
5,55	6	66	30	20	36	SCD121-0555-2-2-140HA03-HP835	30439052
5,60	6	66	30	20	36	SCD121-0560-2-2-140HA03-HP835	30390549
5,70	6	66	30	20	36	SCD121-0570-2-2-140HA03-HP835	30390550
5,80	6	66	30	20	36	SCD121-0580-2-2-140HA03-HP835	30390551
5,90	6	66	30	20	36	SCD121-0590-2-2-140HA03-HP835	30390552
5,95	6	66	30	20	36	SCD121-0595-2-2-140HA03-HP835	30453636
6,00	6	66	30	20	36	SCD121-0600-2-2-140HA03-HP835	30390553

MEGA-Drill-Inox | Punta elicoidale in metallo duro integrale SCD121 (3xD), adduzione interna del refrigerante

Dimensioni						Forma del codolo HA	
d ₁ m7	d ₂ h6	l ₁	l ₂	l ₃	l ₄	Specifiche	Codice
6,10	8	79	38	24	36	SCD121-0610-2-2-140HA03-HP835	30390554
6,20	8	79	38	24	36	SCD121-0620-2-2-140HA03-HP835	30390555
6,30	8	79	38	24	36	SCD121-0630-2-2-140HA03-HP835	30390556
6,40	8	79	38	24	36	SCD121-0640-2-2-140HA03-HP835	30390557
6,50	8	79	38	24	36	SCD121-0650-2-2-140HA03-HP835	30390558
6,60	8	79	38	24	36	SCD121-0660-2-2-140HA03-HP835	30390559
6,70	8	79	38	24	36	SCD121-0670-2-2-140HA03-HP835	30390560
6,80	8	79	38	24	36	SCD121-0680-2-2-140HA03-HP835	30390561
6,90	8	79	38	24	36	SCD121-0690-2-2-140HA03-HP835	30390562
7,00	8	79	38	24	36	SCD121-0700-2-2-140HA03-HP835	30390563
7,10	8	79	42	29	36	SCD121-0710-2-2-140HA03-HP835	30390564
7,20	8	79	42	29	36	SCD121-0720-2-2-140HA03-HP835	30390565
7,30	8	79	42	29	36	SCD121-0730-2-2-140HA03-HP835	30390566
7,40	8	79	42	29	36	SCD121-0740-2-2-140HA03-HP835	30390567
7,45	8	79	42	29	36	SCD121-0745-2-2-140HA03-HP835	30453637
7,50	8	79	42	29	36	SCD121-0750-2-2-140HA03-HP835	30390568
7,70	8	79	42	29	36	SCD121-0770-2-2-140HA03-HP835	30390570
7,80	8	79	42	29	36	SCD121-0780-2-2-140HA03-HP835	30390571
7,90	8	79	42	29	36	SCD121-0790-2-2-140HA03-HP835	30390572
8,00	8	79	42	29	36	SCD121-0800-2-2-140HA03-HP835	30390573
8,10	10	89	49	35	40	SCD121-0810-2-2-140HA03-HP835	30390574
8,20	10	89	49	35	40	SCD121-0820-2-2-140HA03-HP835	30390575
8,30	10	89	49	35	40	SCD121-0830-2-2-140HA03-HP835	30390576
8,40	10	89	49	35	40	SCD121-0840-2-2-140HA03-HP835	30390577
8,50	10	89	49	35	40	SCD121-0850-2-2-140HA03-HP835	30390578
8,60	10	89	49	35	40	SCD121-0860-2-2-140HA03-HP835	30390579
8,70	10	89	49	35	40	SCD121-0870-2-2-140HA03-HP835	30390580
8,80	10	89	49	35	40	SCD121-0880-2-2-140HA03-HP835	30390581
9,00	10	89	49	35	40	SCD121-0900-2-2-140HA03-HP835	30390583
9,10	10	89	49	35	40	SCD121-0910-2-2-140HA03-HP835	30390584
9,20	10	89	49	35	40	SCD121-0920-2-2-140HA03-HP835	30390585
9,30	10	89	49	35	40	SCD121-0930-2-2-140HA03-HP835	30390586
9,35	10	89	49	35	40	SCD121-0935-2-2-140HA03-HP835	30450663
9,40	10	89	49	35	40	SCD121-0940-2-2-140HA03-HP835	30390587
9,50	10	89	49	35	40	SCD121-0950-2-2-140HA03-HP835	30390588
9,70	10	89	49	35	40	SCD121-0970-2-2-140HA03-HP835	30390590
9,80	10	89	49	35	40	SCD121-0980-2-2-140HA03-HP835	30390591
9,90	10	89	49	35	40	SCD121-0990-2-2-140HA03-HP835	30390592
10,00	10	89	49	35	40	SCD121-1000-2-2-140HA03-HP835	30390593
10,20	12	102	56	40	45	SCD121-1020-2-2-140HA03-HP835	30390595
10,30	12	102	56	40	45	SCD121-1030-2-2-140HA03-HP835	30390596
10,40	12	102	56	40	45	SCD121-1040-2-2-140HA03-HP835	30390597
10,50	12	102	56	40	45	SCD121-1050-2-2-140HA03-HP835	30390598
10,70	12	102	56	40	45	SCD121-1070-2-2-140HA03-HP835	30390600
10,80	12	102	56	40	45	SCD121-1080-2-2-140HA03-HP835	30390601
11,00	12	102	56	40	45	SCD121-1100-2-2-140HA03-HP835	30390603
11,10	12	102	56	40	45	SCD121-1110-2-2-140HA03-HP835	30390604
11,30	12	102	56	40	45	SCD121-1130-2-2-140HA03-HP835	30390606
11,50	12	102	56	40	45	SCD121-1150-2-2-140HA03-HP835	30390608
11,70	12	102	56	40	45	SCD121-1170-2-2-140HA03-HP835	30390610
11,80	12	102	56	40	45	SCD121-1180-2-2-140HA03-HP835	30390611
12,00	12	102	56	40	45	SCD121-1200-2-2-140HA03-HP835	30390613
12,15	14	107	61	43	45	SCD121-1215-2-2-140HA03-HP835	30453644
12,50	14	107	61	43	45	SCD121-1250-2-2-140HA03-HP835	30443976
12,80	14	107	61	43	45	SCD121-1280-2-2-140HA03-HP835	30445992
13,00	14	107	61	43	45	SCD121-1300-2-2-140HA03-HP835	30444778
13,50	14	107	61	43	45	SCD121-1350-2-2-140HA03-HP835	30390614

MEGA-Drill-Inox | Punta elicoidale in metallo duro integrale SCD121 (3xD), adduzione interna del refrigerante

Dimensioni						Forma del codolo HA	
d ₁ m7	d ₂ h6	l ₁	l ₂	l ₃	l ₄	Specifiche	Codice
13,80	14	107	61	43	45	SCD121-1380-2-2-140HA03-HP835	30445993
14,00	14	107	61	43	45	SCD121-1400-2-2-140HA03-HP835	30445050
14,50	16	115	65	45	48	SCD121-1450-2-2-140HA03-HP835	30390615
15,00	16	115	65	45	48	SCD121-1500-2-2-140HA03-HP835	30390616
15,50	16	115	65	45	48	SCD121-1550-2-2-140HA03-HP835	30442531
15,80	16	115	65	45	48	SCD121-1580-2-2-140HA03-HP835	30445995
16,00	16	115	65	45	48	SCD121-1600-2-2-140HA03-HP835	30390617
17,50	18	123	73	51	48	SCD121-1750-2-2-140HA03-HP835	30390620
18,00	18	123	73	51	48	SCD121-1800-2-2-140HA03-HP835	30390621
20,00	20	131	79	55	50	SCD121-2000-2-2-140HA03-HP835	30390625

Caratteristiche configurabili

**Diametro:**

Diametro a libera scelta a passi da 0,01 mm

**Forma del codolo:**

Forma del codolo: HB | HE

Specifiche:

SCD121-[diametro]-2-2-140[forma del codolo]03-HP835

Esempio:

SCD121-0431-2-2-140HE03-HP835

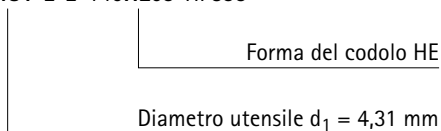

Dimensioni serie configurabile

d ₁ min.	d ₁ max.	d ₂ h6	l ₁	l ₂	l ₃	l ₄
3,71	4,70	6	66	26	17	36
4,71	6,00	6	66	30	20	36
6,01	7,00	8	79	38	24	36
7,01	8,00	8	79	42	29	36
8,01	10,00	10	89	49	35	40
10,01	12,00	12	102	56	40	45
12,01	14,00	14	107	61	43	45
14,01	16,00	16	115	65	45	48
16,01	18,00	18	123	73	51	48
18,01	20,00	20	131	79	55	50
18,01	20,00	20	131	79	55	50

Misure in mm.

Per i parametri di lavorazione consigliati, vedere la fine del capitolo.

Versioni speciali e altri rivestimenti disponibili su richiesta.

MEGA-Drill-Inox

Punta elicoidale in metallo duro integrale
SCD120 (5xD), adduzione esterna di refrigerante

Versione:

Diametro punta: 3,00 – 20,00 mm
Tolleranza di foratura: \geq IT 9
Materiale da taglio: HP835
Numero di taglienti: 2
Numero margini di guida: 2
Angolo tra taglienti: 140°
Angolo dell'elica: 30°

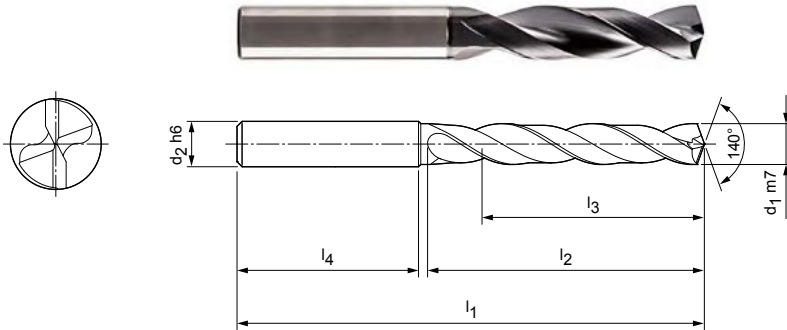

Serie selezionata per il magazzino con forma del codolo HA

Dimensioni						Forma del codolo HA	
d ₁ m7	d ₂ h6	l ₁	l ₂	l ₃	l ₄	Specifiche	Codice
3,00	6	66	28	23	36	SCD120-0300-2-2-140HA05-HP835	30390730
3,10	6	66	28	23	36	SCD120-0310-2-2-140HA05-HP835	30390731
3,20	6	66	28	23	36	SCD120-0320-2-2-140HA05-HP835	30390732
3,30	6	66	28	23	36	SCD120-0330-2-2-140HA05-HP835	30390733
3,40	6	66	28	23	36	SCD120-0340-2-2-140HA05-HP835	30390734
3,50	6	66	28	23	36	SCD120-0350-2-2-140HA05-HP835	30390735
3,60	6	66	28	23	36	SCD120-0360-2-2-140HA05-HP835	30390736
3,70	6	66	28	23	36	SCD120-0370-2-2-140HA05-HP835	30390737
3,80	6	74	36	29	36	SCD120-0380-2-2-140HA05-HP835	30390738
3,90	6	74	36	29	36	SCD120-0390-2-2-140HA05-HP835	30390739
4,00	6	74	36	29	36	SCD120-0400-2-2-140HA05-HP835	30390740
4,10	6	74	36	29	36	SCD120-0410-2-2-140HA05-HP835	30390741
4,20	6	74	36	29	36	SCD120-0420-2-2-140HA05-HP835	30390742
4,30	6	74	36	29	36	SCD120-0430-2-2-140HA05-HP835	30390743
4,40	6	74	36	29	36	SCD120-0440-2-2-140HA05-HP835	30390744
4,50	6	74	36	29	36	SCD120-0450-2-2-140HA05-HP835	30390745
4,60	6	74	36	29	36	SCD120-0460-2-2-140HA05-HP835	30390746
4,70	6	74	36	29	36	SCD120-0470-2-2-140HA05-HP835	30390747
4,80	6	82	44	35	36	SCD120-0480-2-2-140HA05-HP835	30390748
4,90	6	82	44	35	36	SCD120-0490-2-2-140HA05-HP835	30390749
5,00	6	82	44	35	36	SCD120-0500-2-2-140HA05-HP835	30390750
5,10	6	82	44	35	36	SCD120-0510-2-2-140HA05-HP835	30390751
5,20	6	82	44	35	36	SCD120-0520-2-2-140HA05-HP835	30390752
5,30	6	82	44	35	36	SCD120-0530-2-2-140HA05-HP835	30390753
5,40	6	82	44	35	36	SCD120-0540-2-2-140HA05-HP835	30390754
5,50	6	82	44	35	36	SCD120-0550-2-2-140HA05-HP835	30390755
5,60	6	82	44	35	36	SCD120-0560-2-2-140HA05-HP835	30390756
5,80	6	82	44	35	36	SCD120-0580-2-2-140HA05-HP835	30390758
6,00	6	82	44	35	36	SCD120-0600-2-2-140HA05-HP835	30390760
6,10	8	91	53	43	36	SCD120-0610-2-2-140HA05-HP835	30390761
6,20	8	91	53	43	36	SCD120-0620-2-2-140HA05-HP835	30390762
6,30	8	91	53	43	36	SCD120-0630-2-2-140HA05-HP835	30390763
6,40	8	91	53	43	36	SCD120-0640-2-2-140HA05-HP835	30390764
6,50	8	91	53	43	36	SCD120-0650-2-2-140HA05-HP835	30390765
6,60	8	91	53	43	36	SCD120-0660-2-2-140HA05-HP835	30390766

MEGA-Drill-Inox | Punta elicoidale in metallo duro integrale SCD120 (5xD), adduzione esterna del refrigerante

Dimensioni						Forma del codolo HA	
d ₁ m7	d ₂ h6	l ₁	l ₂	l ₃	l ₄	Specifiche	Codice
6,70	8	91	53	43	36	SCD120-0670-2-2-140HA05-HP835	30390767
6,80	8	91	53	43	36	SCD120-0680-2-2-140HA05-HP835	30390768
6,90	8	91	53	43	36	SCD120-0690-2-2-140HA05-HP835	30390769
7,00	8	91	53	43	36	SCD120-0700-2-2-140HA05-HP835	30390770
7,10	8	91	53	43	36	SCD120-0710-2-2-140HA05-HP835	30390771
7,40	8	91	53	43	36	SCD120-0740-2-2-140HA05-HP835	30390774
7,50	8	91	53	43	36	SCD120-0750-2-2-140HA05-HP835	30390775
7,60	8	91	53	43	36	SCD120-0760-2-2-140HA05-HP835	30390776
7,80	8	91	53	43	36	SCD120-0780-2-2-140HA05-HP835	30390778
7,90	8	91	53	43	36	SCD120-0790-2-2-140HA05-HP835	30390779
8,00	8	91	53	43	36	SCD120-0800-2-2-140HA05-HP835	30390780
8,10	10	103	61	49	40	SCD120-0810-2-2-140HA05-HP835	30390781
8,20	10	103	61	49	40	SCD120-0820-2-2-140HA05-HP835	30390782
8,50	10	103	61	49	40	SCD120-0850-2-2-140HA05-HP835	30390785
8,60	10	103	61	49	40	SCD120-0860-2-2-140HA05-HP835	30390786
8,70	10	103	61	49	40	SCD120-0870-2-2-140HA05-HP835	30390787
8,80	10	103	61	49	40	SCD120-0880-2-2-140HA05-HP835	30390788
9,00	10	103	61	49	40	SCD120-0900-2-2-140HA05-HP835	30390790
9,20	10	103	61	49	40	SCD120-0920-2-2-140HA05-HP835	30390792
9,30	10	103	61	49	40	SCD120-0930-2-2-140HA05-HP835	30390793
9,40	10	103	61	49	40	SCD120-0940-2-2-140HA05-HP835	30390794
9,50	10	103	61	49	40	SCD120-0950-2-2-140HA05-HP835	30390795
10,00	10	103	61	49	40	SCD120-1000-2-2-140HA05-HP835	30390800
10,20	12	118	71	56	45	SCD120-1020-2-2-140HA05-HP835	30390802
10,30	12	118	71	56	45	SCD120-1030-2-2-140HA05-HP835	30390803
10,50	12	118	71	56	45	SCD120-1050-2-2-140HA05-HP835	30390805
10,80	12	118	71	56	45	SCD120-1080-2-2-140HA05-HP835	30390808
11,00	12	118	71	56	45	SCD120-1100-2-2-140HA05-HP835	30390810
11,70	12	118	71	56	45	SCD120-1170-2-2-140HA05-HP835	30390817
11,80	12	118	71	56	45	SCD120-1180-2-2-140HA05-HP835	30390818
12,00	12	118	71	56	45	SCD120-1200-2-2-140HA05-HP835	30390820
12,50	14	124	77	60	45	SCD120-1250-2-2-140HA05-HP835	30390821
13,00	14	124	77	60	45	SCD120-1300-2-2-140HA05-HP835	30390822
16,00	16	133	83	63	48	SCD120-1600-2-2-140HA05-HP835	30390828
16,50	18	143	93	71	48	SCD120-1650-2-2-140HA05-HP835	30445987

Caratteristiche configurabili

**Diametro:**

Diametro a libera scelta a passi da 0,01 mm

**Forma del codolo:**

Forma del codolo: HB | HE

Specifiche:

SCD120-[diametro]-2-2-140[forma del codolo]05-HP835

Dimensioni serie configurabile

d ₁ min.	d ₁ max.	d ₂ h6	l ₁	l ₂	l ₃	l ₄
3,00	3,70	6	66	66	23	36
3,71	4,70	6	74	74	29	36
4,71	6,00	6	82	44	35	36
6,01	8,00	8	91	53	43	36
8,01	10,00	10	103	61	49	40
10,01	12,00	12	118	71	56	45
12,01	14,00	14	124	77	60	45
14,01	16,00	16	133	83	63	48
16,01	18,00	18	143	93	71	48
18,01	20,00	20	153	101	77	50

Esempio:

SCD120-0431-2-2-140HE05-HP835

Forma del codolo HE

Diametro utensile d₁ = 4,31 mm

Misure in mm.

Per i parametri di lavorazione consigliati, vedere la fine del capitolo.

Versioni speciali e altri rivestimenti disponibili su richiesta.

MEGA-Drill-Inox

Punta elicoidale in metallo duro integrale
SCD121 (5xD), adduzione interna del refrigerante

Versione:

Diametro punta: 2,80 – 20,00 mm
Tolleranza di foratura: \geq IT 9
Materiale da taglio: HP835
Numero di taglienti: 2
Numero margini di guida: 2
Angolo tra taglienti: 140°
Angolo dell'elica: 30°

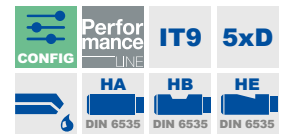
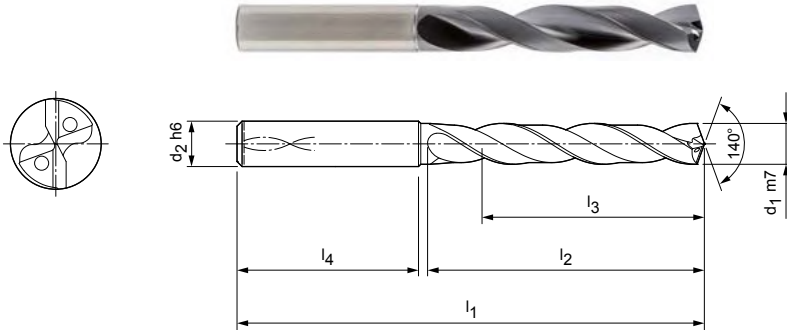

Serie selezionata per il magazzino con forma del codolo HA

Dimensioni						Forma del codolo HA	
d ₁ m7	d ₂ h6	l ₁	l ₂	l ₃	l ₄	Specifiche	Codice
2,80	6	66	28	23	36	SCD121-0280-2-2-140HA05-HP835	30453905
3,00	6	66	28	23	36	SCD121-0300-2-2-140HA05-HP835	30390951
3,10	6	66	28	23	36	SCD121-0310-2-2-140HA05-HP835	30390952
3,15	6	66	28	23	36	SCD121-0315-2-2-140HA05-HP835	30430429
3,20	6	66	28	23	36	SCD121-0320-2-2-140HA05-HP835	30390953
3,22	6	66	28	23	36	SCD121-0322-2-2-140HA05-HP835	30453650
3,25	6	66	28	23	36	SCD121-0325-2-2-140HA05-HP835	30453651
3,30	6	66	28	23	36	SCD121-0330-2-2-140HA05-HP835	30390954
3,40	6	66	28	23	36	SCD121-0340-2-2-140HA05-HP835	30390955
3,50	6	66	28	23	36	SCD121-0350-2-2-140HA05-HP835	30390956
3,60	6	66	28	23	36	SCD121-0360-2-2-140HA05-HP835	30390957
3,70*	6	66	28	23	36	SCD121-0370-2-2-140HA05-HP835	30390958
3,80	6	74	36	29	36	SCD121-0380-2-2-140HA05-HP835	30390959
3,90	6	74	36	29	36	SCD121-0390-2-2-140HA05-HP835	30390960
4,00	6	74	36	29	36	SCD121-0400-2-2-140HA05-HP835	30390961
4,10	6	74	36	29	36	SCD121-0410-2-2-140HA05-HP835	30390962
4,15	6	74	36	29	36	SCD121-0415-2-2-140HA05-HP835	30454007
4,20	6	74	36	29	36	SCD121-0420-2-2-140HA05-HP835	30390963
4,30	6	74	36	29	36	SCD121-0430-2-2-140HA05-HP835	30390964
4,40	6	74	36	29	36	SCD121-0440-2-2-140HA05-HP835	30390965
4,45	6	74	36	29	36	SCD121-0445-2-2-140HA05-HP835	30453654
4,50	6	74	36	29	36	SCD121-0450-2-2-140HA05-HP835	30390966
4,60	6	74	36	29	36	SCD121-0460-2-2-140HA05-HP835	30390967
4,65*	6	74	36	29	36	SCD121-0465-2-2-140HA05-HP835	30453655
4,70	6	74	36	29	36	SCD121-0470-2-2-140HA05-HP835	30390968
4,80	6	82	44	35	36	SCD121-0480-2-2-140HA05-HP835	30390969
4,90	6	82	44	35	36	SCD121-0490-2-2-140HA05-HP835	30390970
5,00	6	82	44	35	36	SCD121-0500-2-2-140HA05-HP835	30390971
5,10	6	82	44	35	36	SCD121-0510-2-2-140HA05-HP835	30390972
5,20	6	82	44	35	36	SCD121-0520-2-2-140HA05-HP835	30390973
5,30	6	82	44	35	36	SCD121-0530-2-2-140HA05-HP835	30390974
5,40	6	82	44	35	36	SCD121-0540-2-2-140HA05-HP835	30390975
5,50	6	82	44	35	36	SCD121-0550-2-2-140HA05-HP835	30390976
5,60	6	82	44	35	36	SCD121-0560-2-2-140HA05-HP835	30390977
5,70	6	82	44	35	36	SCD121-0570-2-2-140HA05-HP835	30390978

MEGA-Drill-Inox | Punta elicoidale in metallo duro integrale SCD121 (5xD), adduzione interna del refrigerante

Dimensioni						Forma del codolo HA	
d ₁ m7	d ₂ h6	l ₁	l ₂	l ₃	l ₄	Specifiche	Codice
5,80	6	82	44	35	36	SCD121-0580-2-2-140HA05-HP835	30390979
5,90	6	82	44	35	36	SCD121-0590-2-2-140HA05-HP835	30390980
5,95	6	82	44	35	36	SCD121-0595-2-2-140HA05-HP835	30453657
6,00	6	82	44	35	36	SCD121-0600-2-2-140HA05-HP835	30390981
6,10	8	91	53	43	36	SCD121-0610-2-2-140HA05-HP835	30390982
6,20	8	91	53	43	36	SCD121-0620-2-2-140HA05-HP835	30390983
6,30	8	91	53	43	36	SCD121-0630-2-2-140HA05-HP835	30390984
6,40	8	91	53	43	36	SCD121-0640-2-2-140HA05-HP835	30390985
6,50	8	91	53	43	36	SCD121-0650-2-2-140HA05-HP835	30390986
6,60	8	91	53	43	36	SCD121-0660-2-2-140HA05-HP835	30390987
6,70	8	91	53	43	36	SCD121-0670-2-2-140HA05-HP835	30390988
6,80	8	91	53	43	36	SCD121-0680-2-2-140HA05-HP835	30390989
6,90	8	91	53	43	36	SCD121-0690-2-2-140HA05-HP835	30390990
7,00	8	91	53	43	36	SCD121-0700-2-2-140HA05-HP835	30390991
7,10	8	91	53	43	36	SCD121-0710-2-2-140HA05-HP835	30390992
7,20	8	91	53	43	36	SCD121-0720-2-2-140HA05-HP835	30390993
7,30	8	91	53	43	36	SCD121-0730-2-2-140HA05-HP835	30390994
7,40	8	91	53	43	36	SCD121-0740-2-2-140HA05-HP835	30390995
7,45*	8	91	53	43	36	SCD121-0745-2-2-140HA05-HP835	30453658
7,50	8	91	53	43	36	SCD121-0750-2-2-140HA05-HP835	30390996
7,60	8	91	53	43	36	SCD121-0760-2-2-140HA05-HP835	30390997
7,70	8	91	53	43	36	SCD121-0770-2-2-140HA05-HP835	30390998
7,80	8	91	53	43	36	SCD121-0780-2-2-140HA05-HP835	30390999
8,00	8	91	53	43	36	SCD121-0800-2-2-140HA05-HP835	30391001
8,10	10	103	61	49	40	SCD121-0810-2-2-140HA05-HP835	30391002
8,20	10	103	61	49	40	SCD121-0820-2-2-140HA05-HP835	30391003
8,30	10	103	61	49	40	SCD121-0830-2-2-140HA05-HP835	30391004
8,50	10	103	61	49	40	SCD121-0850-2-2-140HA05-HP835	30391006
8,60	10	103	61	49	40	SCD121-0860-2-2-140HA05-HP835	30391007
8,70	10	103	61	49	40	SCD121-0870-2-2-140HA05-HP835	30391008
8,80	10	103	61	49	40	SCD121-0880-2-2-140HA05-HP835	30391009
8,90	10	103	61	49	40	SCD121-0890-2-2-140HA05-HP835	30391010
9,00	10	103	61	49	40	SCD121-0900-2-2-140HA05-HP835	30391011
9,10	10	103	61	49	40	SCD121-0910-2-2-140HA05-HP835	30391012
9,35	10	103	61	49	40	SCD121-0935-2-2-140HA05-HP835	30450706
9,40	10	103	61	49	40	SCD121-0940-2-2-140HA05-HP835	30391015
9,45	10	103	61	49	40	SCD121-0945-2-2-140HA05-HP835	30453660
9,50	10	103	61	49	40	SCD121-0950-2-2-140HA05-HP835	30391016
9,80	10	103	61	49	40	SCD121-0980-2-2-140HA05-HP835	30391019
9,90	10	103	61	49	40	SCD121-0990-2-2-140HA05-HP835	30391020
10,00	10	103	61	49	40	SCD121-1000-2-2-140HA05-HP835	30391021
10,20	12	118	71	56	45	SCD121-1020-2-2-140HA05-HP835	30391023
10,30	12	118	71	56	45	SCD121-1030-2-2-140HA05-HP835	30391024
10,50	12	118	71	56	45	SCD121-1050-2-2-140HA05-HP835	30391026
10,55	12	118	71	56	45	SCD121-1055-2-2-140HA05-HP835	30453661
10,80	12	118	71	56	45	SCD121-1080-2-2-140HA05-HP835	30391029
11,00	12	118	71	56	45	SCD121-1100-2-2-140HA05-HP835	30391031
11,20*	12	118	71	56	45	SCD121-1120-2-2-140HA05-HP835	30391033
11,25	12	118	71	56	45	SCD121-1125-2-2-140HA05-HP835	30453662
11,30	12	118	71	56	45	SCD121-1130-2-2-140HA05-HP835	30391034
11,50	12	118	71	56	45	SCD121-1150-2-2-140HA05-HP835	30391036
11,70	12	118	71	56	45	SCD121-1170-2-2-140HA05-HP835	30391038
11,80	12	118	71	56	45	SCD121-1180-2-2-140HA05-HP835	30391039
12,00	12	118	71	56	45	SCD121-1200-2-2-140HA05-HP835	30391041
12,50	14	124	77	60	45	SCD121-1250-2-2-140HA05-HP835	30391042
13,00	14	124	77	60	45	SCD121-1300-2-2-140HA05-HP835	30391044
13,50	14	124	77	60	45	SCD121-1350-2-2-140HA05-HP835	30391045

MEGA-Drill-Inox | Punta elicoidale in metallo duro integrale SCD121 (5xD), adduzione interna del refrigerante

Dimensioni						Forma del codolo HA	
d ₁ m7	d ₂ h6	l ₁	l ₂	l ₃	l ₄	Specifiche	Codice
13,80	14	124	77	60	45	SCD121-1380-2-2-140HA05-HP835	30391046
14,00	14	124	77	60	45	SCD121-1400-2-2-140HA05-HP835	30391047
15,00	16	133	83	63	48	SCD121-1500-2-2-140HA05-HP835	30391050
16,00	16	133	83	63	48	SCD121-1600-2-2-140HA05-HP835	30391053
16,50	18	143	93	71	48	SCD121-1650-2-2-140HA05-HP835	30391054
17,00	18	143	93	71	48	SCD121-1700-2-2-140HA05-HP835	30391056
18,00	18	143	93	71	48	SCD121-1800-2-2-140HA05-HP835	30391059
20,00	20	153	101	77	50	SCD121-2000-2-2-140HA05-HP835	30391065

Caratteristiche configurabili

**Diametro:**

Diametro a libera scelta a passi da 0,01 mm

**Forma del codolo:**

Forma del codolo: HB | HE

Specifiche:

SCD121-[diametro]-2-2-140[forma del codolo]05-HP835

Dimensioni serie configurabile

d ₁ min.	d ₁ max.	d ₂ h6	l ₁	l ₂	l ₃	l ₄
3,71	4,70	6	74	36	29	36
4,71	6,00	6	82	44	35	36
6,01	8,00	8	91	53	43	36
8,01	10,00	10	103	61	49	40
10,01	12,00	12	118	71	56	45
12,01	14,00	14	124	77	60	45
14,01	16,00	16	133	83	63	45
16,01	18,00	18	143	93	71	48
18,01	20,00	20	153	101	77	50

Esempio:

SCD121-0431-2-2-140HE05-HP835

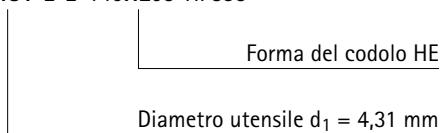

Misure in mm.

* Specifica per la prefabbricazione di fori da maschiare per maschi a filettare.

Per i parametri di lavorazione consigliati, vedere la fine del capitolo.

Versioni speciali e altri rivestimenti disponibili su richiesta.

MEGA-Drill-Inox

Punta elicoidale in metallo duro integrale
SCD121 (8xD), adduzione interna del refrigerante

Versione:

Diametro punta: 3,00 – 20,00 mm
Tolleranza di foratura: \geq IT 9
Materiale da taglio: HP835
Numero di taglienti: 2
Numero margini di guida: 2
Angolo tra taglienti: 140°
Angolo dell'elica: 30°

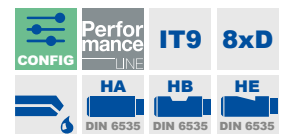
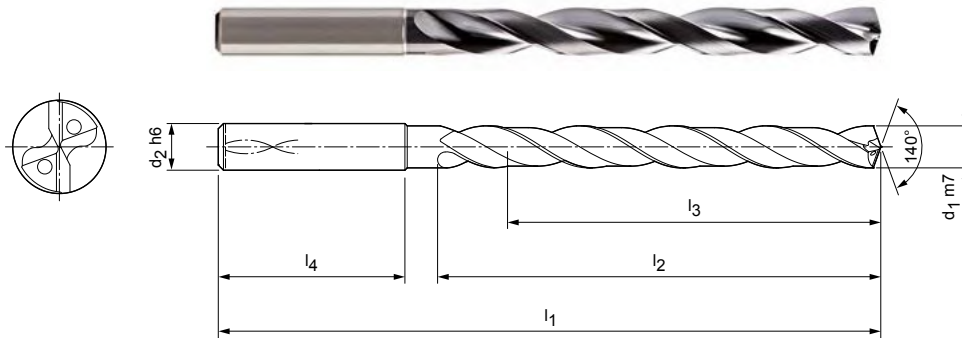

Serie selezionata per il magazzino con forma del codolo HA

Dimensioni						Forma del codolo HA	
d ₁ m7	d ₂ h6	l ₁	l ₂	l ₃	l ₄	Specifiche	Codice
3,00	6	72	34	29	36	SCD121-0300-2-2-140HA08-HP835	30391171
3,20	6	72	34	29	36	SCD121-0320-2-2-140HA08-HP835	30391173
3,30	6	72	34	29	36	SCD121-0330-2-2-140HA08-HP835	30391174
3,40	6	72	34	29	36	SCD121-0340-2-2-140HA08-HP835	30391175
3,50	6	72	34	29	36	SCD121-0350-2-2-140HA08-HP835	30391176
3,70	6	72	34	29	36	SCD121-0370-2-2-140HA08-HP835	30391178
3,80	6	81	43	36	36	SCD121-0380-2-2-140HA08-HP835	30391179
3,90	6	81	43	36	36	SCD121-0390-2-2-140HA08-HP835	30391180
4,00	6	81	43	36	36	SCD121-0400-2-2-140HA08-HP835	30391181
4,20	6	81	43	36	36	SCD121-0420-2-2-140HA08-HP835	30391183
4,30	6	81	43	36	36	SCD121-0430-2-2-140HA08-HP835	30391184
4,40	6	81	43	36	36	SCD121-0440-2-2-140HA08-HP835	30391185
4,50	6	81	43	36	36	SCD121-0450-2-2-140HA08-HP835	30391186
4,80	6	95	57	48	36	SCD121-0480-2-2-140HA08-HP835	30391189
4,90	6	95	57	48	36	SCD121-0490-2-2-140HA08-HP835	30391190
5,00	6	95	57	48	36	SCD121-0500-2-2-140HA08-HP835	30391191
5,10	6	95	57	48	36	SCD121-0510-2-2-140HA08-HP835	30391192
5,30	6	95	57	48	36	SCD121-0530-2-2-140HA08-HP835	30391194
5,50	6	95	57	48	36	SCD121-0550-2-2-140HA08-HP835	30391196
5,60	6	95	57	48	36	SCD121-0560-2-2-140HA08-HP835	30391197
5,80	6	95	57	48	36	SCD121-0580-2-2-140HA08-HP835	30391199
5,90	6	95	57	48	36	SCD121-0590-2-2-140HA08-HP835	30391200
6,00	6	95	57	48	36	SCD121-0600-2-2-140HA08-HP835	30391201
6,10	8	114	76	64	36	SCD121-0610-2-2-140HA08-HP835	30391202
6,50	8	114	76	64	36	SCD121-0650-2-2-140HA08-HP835	30391206
6,60	8	114	76	64	36	SCD121-0660-2-2-140HA08-HP835	30391207
6,70	8	114	76	64	36	SCD121-0670-2-2-140HA08-HP835	30391208
6,80	8	114	76	64	36	SCD121-0680-2-2-140HA08-HP835	30391209
6,90	8	114	76	64	36	SCD121-0690-2-2-140HA08-HP835	30391210
7,00	8	114	76	64	36	SCD121-0700-2-2-140HA08-HP835	30391212
7,20	8	114	76	64	36	SCD121-0720-2-2-140HA08-HP835	30391214
7,50	8	114	76	64	36	SCD121-0750-2-2-140HA08-HP835	30391217
7,60	8	114	76	64	36	SCD121-0760-2-2-140HA08-HP835	30391218
7,80	8	114	76	64	36	SCD121-0780-2-2-140HA08-HP835	30391220
8,00	8	114	76	64	36	SCD121-0800-2-2-140HA08-HP835	30391222

MEGA-Drill-Inox | Punta elicoidale in metallo duro integrale SCD121 (8xD), adduzione interna del refrigerante

Dimensioni						Forma del codolo HA	
d ₁ m7	d ₂ h6	l ₁	l ₂	l ₃	l ₄	Specifiche	Codice
8,50	10	142	95	80	40	SCD121-0850-2-2-140HA08-HP835	30391227
8,90	10	142	95	80	40	SCD121-0890-2-2-140HA08-HP835	30391231
9,00	10	142	95	80	40	SCD121-0900-2-2-140HA08-HP835	30391232
9,10	10	142	95	80	40	SCD121-0910-2-2-140HA08-HP835	30391233
9,30	10	142	95	80	40	SCD121-0930-2-2-140HA08-HP835	30391235
9,50	10	142	95	80	40	SCD121-0950-2-2-140HA08-HP835	30391237
9,60	10	142	95	80	40	SCD121-0960-2-2-140HA08-HP835	30391238
9,70	10	142	95	80	40	SCD121-0970-2-2-140HA08-HP835	30391239
9,80	10	142	95	80	40	SCD121-0980-2-2-140HA08-HP835	30391240
10,00	10	142	95	80	40	SCD121-1000-2-2-140HA08-HP835	30391242
10,10	12	162	114	96	45	SCD121-1010-2-2-140HA08-HP835	30391243
10,20	12	162	114	96	45	SCD121-1020-2-2-140HA08-HP835	30391244
10,80	12	162	114	96	45	SCD121-1080-2-2-140HA08-HP835	30391250
11,00	12	162	114	96	45	SCD121-1100-2-2-140HA08-HP835	30391252
11,50	12	162	114	96	45	SCD121-1150-2-2-140HA08-HP835	30391257
11,80	12	162	114	96	45	SCD121-1180-2-2-140HA08-HP835	30391260
12,00	12	162	114	96	45	SCD121-1200-2-2-140HA08-HP835	30391262
13,00	14	178	133	112	45	SCD121-1300-2-2-140HA08-HP835	30391265
13,50	14	178	133	112	45	SCD121-1350-2-2-140HA08-HP835	30391266
14,00	14	178	133	112	45	SCD121-1400-2-2-140HA08-HP835	30391268
14,50	16	203	152	128	48	SCD121-1450-2-2-140HA08-HP835	30391269
15,00	16	203	152	128	48	SCD121-1500-2-2-140HA08-HP835	30391271
18,00	18	222	171	144	48	SCD121-1800-2-2-140HA08-HP835	30391280

Caratteristiche configurabili

**Diametro:**

Diametro a libera scelta a passi da 0,01 mm

**Forma del codolo:**

Forma del codolo: HB | HE

Specifiche:

SCD121-[diametro]-2-2-140[forma del codolo]08-HP835

Dimensioni serie configurabile

d ₁ min.	d ₁ max.	d ₂ h6	l ₁	l ₂	l ₃	l ₄
3,71	4,70	6	81	43	36	36
4,71	6,00	6	95	57	48	36
6,01	8,00	8	114	76	64	36
8,01	10,00	10	142	95	80	40
10,01	12,00	12	162	114	96	45
12,01	14,00	14	178	133	112	45
14,01	16,00	16	203	152	128	48
16,01	18,00	18	222	171	144	48
18,01	20,00	20	243	190	160	50
16,01	18,00	18	123	73	51	48
18,01	20,00	20	131	79	55	50

Esempio:

SCD121-0431-2-2-140HE08-HP835

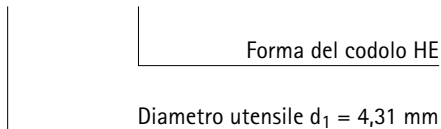

Misure in mm.

Per i parametri di lavorazione consigliati, vedere la fine del capitolo.

Versioni speciali e altri rivestimenti disponibili su richiesta.

MEGA-Speed-Drill-Inox

Punta elicoidale in metallo duro integrale
SCD411 (5xD), adduzione interna del refrigerante

Versione:

Diametro punta: 3,00 – 20,00 mm
Tolleranza di foratura: \geq IT 9
Materiale da taglio: HP374
Numero di taglienti: 2
Numero margini di guida: 3
Angolo tra taglienti: 135°
Angolo dell'elica: 30°

Applicazione

Per lavorazioni ad alta velocità.

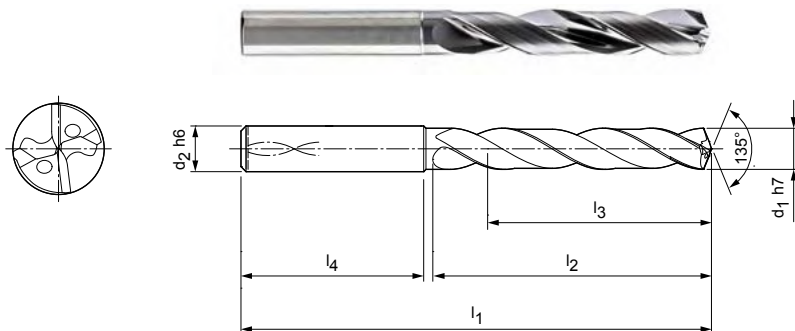

Serie selezionata per il magazzino con forma del codolo HA

Dimensioni						Forma del codolo HA	
d_1 h7	d_2 h6	l_1	l_2	l_3	l_4	Specifiche	Codice
3,00	6	66	28	23	36	SCD411-0300-2-3-135HA05-HP374	30488182
3,10	6	66	28	23	36	SCD411-0310-2-3-135HA05-HP374	30488183
3,20	6	66	28	23	36	SCD411-0320-2-3-135HA05-HP374	30488184
3,30	6	66	28	23	36	SCD411-0330-2-3-135HA05-HP374	30488185
3,40	6	66	28	23	36	SCD411-0340-2-3-135HA05-HP374	30488186
3,50	6	66	28	23	36	SCD411-0350-2-3-135HA05-HP374	30488187
3,70	6	66	28	23	36	SCD411-0370-2-3-135HA05-HP374	30488189
3,80	6	74	36	29	36	SCD411-0380-2-3-135HA05-HP374	30488190
4,00	6	74	36	29	36	SCD411-0400-2-3-135HA05-HP374	30488192
4,10	6	74	36	29	36	SCD411-0410-2-3-135HA05-HP374	30488193
4,20	6	74	36	29	36	SCD411-0420-2-3-135HA05-HP374	30488194
4,30	6	74	36	29	36	SCD411-0430-2-3-135HA05-HP374	30488195
4,50	6	74	36	29	36	SCD411-0450-2-3-135HA05-HP374	30488197
4,65	6	74	36	29	36	SCD411-0465-2-3-135HA05-HP374	30488199
4,70	6	74	36	29	36	SCD411-0470-2-3-135HA05-HP374	30488200
4,80	6	82	44	35	36	SCD411-0480-2-3-135HA05-HP374	30488201
5,00	6	82	44	35	36	SCD411-0500-2-3-135HA05-HP374	30488203
5,10	6	82	44	35	36	SCD411-0510-2-3-135HA05-HP374	30488204
5,20	6	82	44	35	36	SCD411-0520-2-3-135HA05-HP374	30488205
5,30	6	82	44	35	36	SCD411-0530-2-3-135HA05-HP374	30488206
5,50	6	82	44	35	36	SCD411-0550-2-3-135HA05-HP374	30488208
5,55	6	82	44	35	36	SCD411-0555-2-3-135HA05-HP374	30488209
5,60	6	82	44	35	36	SCD411-0560-2-3-135HA05-HP374	30488210
5,80	6	82	44	35	36	SCD411-0580-2-3-135HA05-HP374	30488212
5,90	6	82	44	35	36	SCD411-0590-2-3-135HA05-HP374	30488213
6,00	6	82	44	35	36	SCD411-0600-2-3-135HA05-HP374	30488214
6,10	8	91	53	43	36	SCD411-0610-2-3-135HA05-HP374	30488215
6,30	8	91	53	43	36	SCD411-0630-2-3-135HA05-HP374	30488217
6,50	8	91	53	43	36	SCD411-0650-2-3-135HA05-HP374	30488219
6,60	8	91	53	43	36	SCD411-0660-2-3-135HA05-HP374	30488220
6,80	8	91	53	43	36	SCD411-0680-2-3-135HA05-HP374	30488222
6,90	8	91	53	43	36	SCD411-0690-2-3-135HA05-HP374	30488223
7,00	8	91	53	43	36	SCD411-0700-2-3-135HA05-HP374	30488224
7,30	8	91	53	43	36	SCD411-0730-2-3-135HA05-HP374	30488227
7,40	8	91	53	43	36	SCD411-0740-2-3-135HA05-HP374	30488228

MEGA-Speed-Drill-Inox | Punta elicoidale in metallo duro integrale SCD411 (5xD), adduzione interna del refrigerante

Dimensioni						Forma del codolo HA	
d ₁ h7	d ₂ h6	l ₁	l ₂	l ₃	l ₄	Specifiche	Codice
7,50	8	91	53	43	36	SCD411-0750-2-3-135HA05-HP374	30488229
7,60	8	91	53	43	36	SCD411-0760-2-3-135HA05-HP374	30488230
7,80	8	91	53	43	36	SCD411-0780-2-3-135HA05-HP374	30488232
8,00	8	91	53	43	36	SCD411-0800-2-3-135HA05-HP374	30488234
8,30	10	103	61	49	40	SCD411-0830-2-3-135HA05-HP374	30488237
8,50	10	103	61	49	40	SCD411-0850-2-3-135HA05-HP374	30488239
8,60	10	103	61	49	40	SCD411-0860-2-3-135HA05-HP374	30488240
8,70	10	103	61	49	40	SCD411-0870-2-3-135HA05-HP374	30488241
8,80	10	103	61	49	40	SCD411-0880-2-3-135HA05-HP374	30488242
8,90	10	103	61	49	40	SCD411-0890-2-3-135HA05-HP374	30488243
9,00	10	103	61	49	40	SCD411-0900-2-3-135HA05-HP374	30488244
9,20	10	103	61	49	40	SCD411-0920-2-3-135HA05-HP374	30488246
9,50	10	103	61	49	40	SCD411-0950-2-3-135HA05-HP374	30488249
9,70	10	103	61	49	40	SCD411-0970-2-3-135HA05-HP374	30488251
9,80	10	103	61	49	40	SCD411-0980-2-3-135HA05-HP374	30488252
9,90	10	103	61	49	40	SCD411-0990-2-3-135HA05-HP374	30488253
10,00	10	103	61	49	40	SCD411-1000-2-3-135HA05-HP374	30488254
10,20	12	118	71	56	45	SCD411-1020-2-3-135HA05-HP374	30488256
10,30	12	118	71	56	45	SCD411-1030-2-3-135HA05-HP374	30488257
10,50	12	118	71	56	45	SCD411-1050-2-3-135HA05-HP374	30488259
10,80	12	118	71	56	45	SCD411-1080-2-3-135HA05-HP374	30488262
11,00	12	118	71	56	45	SCD411-1100-2-3-135HA05-HP374	30488264
11,50	12	118	71	56	45	SCD411-1150-2-3-135HA05-HP374	30488269
11,80	12	118	71	56	45	SCD411-1180-2-3-135HA05-HP374	30488272
12,00	12	118	71	56	45	SCD411-1200-2-3-135HA05-HP374	30488274
12,20	14	124	77	60	45	SCD411-1220-2-3-135HA05-HP374	31307527
12,50	14	124	77	60	45	SCD411-1250-2-3-135HA05-HP374	30488275
12,80	14	124	77	60	45	SCD411-1280-2-3-135HA05-HP374	30488276
13,00	14	124	77	60	45	SCD411-1300-2-3-135HA05-HP374	30488277
13,50	14	124	77	60	45	SCD411-1350-2-3-135HA05-HP374	30488278
14,00	14	124	77	60	45	SCD411-1400-2-3-135HA05-HP374	30488280
14,20	16	133	83	63	48	SCD411-1420-2-3-135HA05-HP374	30661538
14,50	16	133	83	71	48	SCD411-1450-2-3-135HA05-HP374	30488281
15,00	16	133	83	71	48	SCD411-1500-2-3-135HA05-HP374	30488283
16,00	16	133	83	71	48	SCD411-1600-2-3-135HA05-HP374	30488286
17,00	18	143	93	71	48	SCD411-1700-2-3-135HA05-HP374	30488289
17,50	18	143	93	71	48	SCD411-1750-2-3-135HA05-HP374	30488290
18,00	18	143	93	71	48	SCD411-1800-2-3-135HA05-HP374	30488292
18,50	20	153	101	77	50	SCD411-1850-2-3-135HA05-HP374	30488293
20,00	20	153	101	77	50	SCD411-2000-2-3-135HA05-HP374	30488298

Prosegue alla pagina seguente.

MEGA-Speed-Drill-Inox | Punta elicoidale in metallo duro integrale SCD411 (5xD), adduzione interna del refrigerante

Caratteristiche configurabili

**Diametro:**

Diametro a libera scelta a passi da 0,01 mm

**Forma del codolo:**

Forma del codolo: HB | HE

Specifiche:

SCD411-[diametro]-2-3-135[forma del codolo]05-HP374

Dimensioni serie configurabile

d ₁ min.	d ₁ max.	d ₂ h6	l ₁	l ₂	l ₃	l ₄
3,00	3,70	6	66	28	23	36
3,71	4,70	6	74	36	29	36
4,71	6,00	6	82	44	35	36
6,01	8,00	8	91	53	43	36
8,01	10,00	10	103	61	49	40
10,01	12,00	12	118	71	56	45
12,01	14,00	14	124	77	60	45
14,01	16,00	16	133	83	63	48
16,01	18,00	18	143	93	71	48
18,01	20,00	20	153	101	77	50

Esempio:

SCD411-0431-2-3-140HE05-HP374

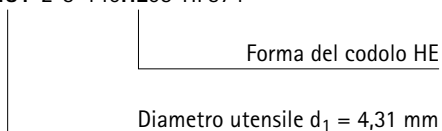

Misure in mm.

Per i parametri di lavorazione consigliati, vedere la fine del capitolo.

Versioni speciali e altri rivestimenti disponibili su richiesta.

MEGA-Speed-Drill-Inox

Punta elicoidale in metallo duro integrale
SCD411 (8xD), adduzione interna del refrigerante

Versione:

Diametro punta: 3,00 – 20,00 mm
Tolleranza di foratura: \geq IT 9
Materiale da taglio: HP374
Numero di taglienti: 2
Numero margini di guida: 3
Angolo tra taglienti: 135°
Angolo dell'elica: 30°

Applicazione:

Per lavorazioni ad alta velocità.

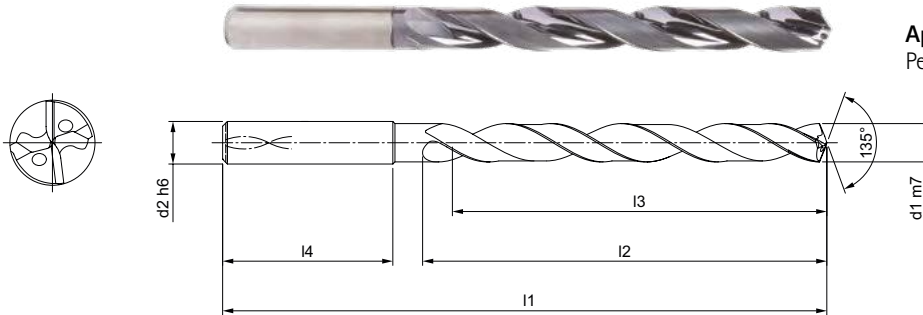

Serie selezionata per il magazzino con forma del codolo HA

Dimensioni						Forma del codolo HA	
d ₁ m7	d ₂ h6	l ₁	l ₂	l ₃	l ₄	Specifiche	Codice
3,00	6	72	34	29	36	SCD411-0300-2-3-135HA08-HP374	31159372
3,20	6	72	34	29	36	SCD411-0320-2-3-135HA08-HP374	31159374
3,30	6	72	34	29	36	SCD411-0330-2-3-135HA08-HP374	31159375
3,40	6	72	34	29	36	SCD411-0340-2-3-135HA08-HP374	31159376
3,50	6	72	34	29	36	SCD411-0350-2-3-135HA08-HP374	31159377
3,70	6	72	34	29	36	SCD411-0370-2-3-135HA08-HP374	31159379
3,90	6	81	43	36	36	SCD411-0390-2-3-135HA08-HP374	31159391
4,00	6	81	43	36	36	SCD411-0400-2-3-135HA08-HP374	31159392
4,10	6	81	43	36	36	SCD411-0410-2-3-135HA08-HP374	31159393
4,20	6	81	43	36	36	SCD411-0420-2-3-135HA08-HP374	31159394
4,30	6	81	43	36	36	SCD411-0430-2-3-135HA08-HP374	31159395
4,50	6	81	43	36	36	SCD411-0450-2-3-135HA08-HP374	31159397
4,60	6	81	43	36	36	SCD411-0460-2-3-135HA08-HP374	31159398
4,80	6	95	57	48	36	SCD411-0480-2-3-135HA08-HP374	31159401
5,00	6	95	57	48	36	SCD411-0500-2-3-135HA08-HP374	31159403
5,10	6	95	57	48	36	SCD411-0510-2-3-135HA08-HP374	31159404
5,20	6	95	57	48	36	SCD411-0520-2-3-135HA08-HP374	31159405
5,40	6	95	57	48	36	SCD411-0540-2-3-135HA08-HP374	31159407
5,50	6	95	57	48	36	SCD411-0550-2-3-135HA08-HP374	31159408
5,80	6	95	57	48	36	SCD411-0580-2-3-135HA08-HP374	31159412
6,00	6	95	57	48	36	SCD411-0600-2-3-135HA08-HP374	31159414
6,10	8	114	76	64	36	SCD411-0610-2-3-135HA08-HP374	31159415
6,50	8	114	76	64	36	SCD411-0650-2-3-135HA08-HP374	31159419
6,80	8	114	76	64	36	SCD411-0680-2-3-135HA08-HP374	31159422
7,00	8	114	76	64	36	SCD411-0700-2-3-135HA08-HP374	31159424
7,50	8	114	76	64	36	SCD411-0750-2-3-135HA08-HP374	31159429
7,80	8	114	76	64	36	SCD411-0780-2-3-135HA08-HP374	31159432
8,00	8	114	76	64	36	SCD411-0800-2-3-135HA08-HP374	31159434
8,50	10	142	95	80	40	SCD411-0850-2-3-135HA08-HP374	31159439
9,00	10	142	95	80	40	SCD411-0900-2-3-135HA08-HP374	31159444
9,30	10	142	95	80	40	SCD411-0930-2-3-135HA08-HP374	31159447
9,50	10	142	95	80	40	SCD411-0950-2-3-135HA08-HP374	31159449
9,80	10	142	95	80	40	SCD411-0980-2-3-135HA08-HP374	31159452
10,00	10	142	95	80	40	SCD411-1000-2-3-135HA08-HP374	31159454
10,20	12	162	114	96	45	SCD411-1020-2-3-135HA08-HP374	31159456

MEGA-Speed-Drill-Inox | Punta elicoidale in metallo duro integrale SCD411 (8xD), adduzione interna del refrigerante

Dimensioni						Forma del codolo HA	
d ₁ m7	d ₂ h6	l ₁	l ₂	l ₃	l ₄	Specifiche	Codice
10,50	12	162	114	96	45	SCD411-1050-2-3-135HA08-HP374	31159459
11,00	12	162	114	96	45	SCD411-1100-2-3-135HA08-HP374	31159464
11,80	12	162	114	96	45	SCD411-1180-2-3-135HA08-HP374	31159472
12,00	12	162	114	96	45	SCD411-1200-2-3-135HA08-HP374	31159474
12,50	14	178	133	112	45	SCD411-1250-2-3-135HA08-HP374	31159476
13,00	14	178	133	112	45	SCD411-1300-2-3-135HA08-HP374	31159478
13,50	14	178	133	112	45	SCD411-1350-2-3-135HA08-HP374	31159479
14,00	14	178	133	112	45	SCD411-1400-2-3-135HA08-HP374	31159481
15,00	16	203	152	128	48	SCD411-1500-2-3-135HA08-HP374	31159485
16,00	16	203	152	128	48	SCD411-1600-2-3-135HA08-HP374	31159489

Caratteristiche configurabili

**Diametro:**

Diametro a libera scelta a passi da
0,01 mm

**Forma del codolo:**

Forma del codolo: HB | HE

Specifiche:

SCD411-[diametro]-2-3-135[forma del codolo]08-HP374

Dimensioni serie configurabile

d ₁ min.	d ₁ max.	d ₂ h6	l ₁	l ₂	l ₃	l ₄
3,00	3,70	6	72	34	29	36
3,71	4,70	6	81	43	36	36
4,71	6,00	6	95	57	48	36
6,01	8,00	8	114	76	64	36
8,01	10,00	10	142	95	80	40
10,01	12,00	12	162	114	96	45
12,01	14,00	14	178	133	112	45
14,01	16,00	16	203	152	128	48
16,01	18,00	18	222	171	144	48
18,01	20,00	20	243	190	160	50

Esempio:

SCD411-0431-2-3-140HE08-HP374

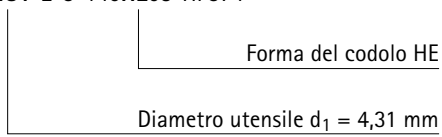

Misure in mm.

Per i parametri di lavorazione consigliati, vedere la fine del capitolo.

Versioni speciali e altri rivestimenti disponibili su richiesta.

MEGA-Speed-Drill-Inox

Punta elicoidale in metallo duro integrale
SCD411 (12xD), adduzione interna del refrigerante

Versione:

Diametro punta: 3,00 – 20,00 mm
Tolleranza di foratura: \geq IT 9
Materiale da taglio: HP374
Numero di taglienti: 2
Numero margini di guida: 3
Angolo tra taglienti: 135°
Angolo dell'elica: 30°

Applicazione:

Per lavorazioni ad alta velocità.

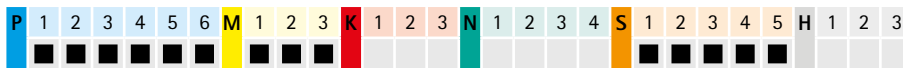
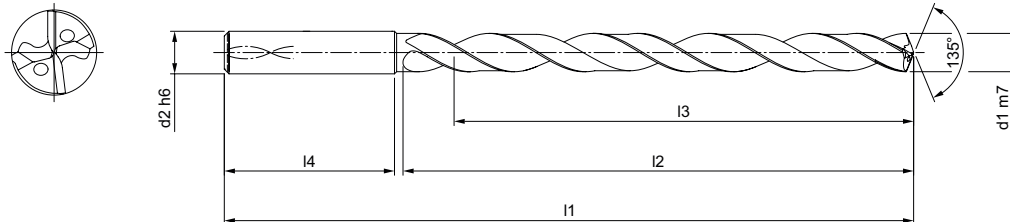

Serie selezionata per il magazzino con forma del codolo HA

Dimensioni						Forma del codolo HA	
d ₁ m7	d ₂ h6	l ₁	l ₂	l ₃	l ₄	Specifiche	Codice
3,00	6	92	54	48	36	SCD411-0300-2-3-135HA12-HP374	31132678
3,10	6	92	54	48	36	SCD411-0310-2-3-135HA12-HP374	31132679
3,20	6	92	54	48	36	SCD411-0320-2-3-135HA12-HP374	31132690
3,30	6	92	54	48	36	SCD411-0330-2-3-135HA12-HP374	31132691
3,40	6	92	54	48	36	SCD411-0340-2-3-135HA12-HP374	31132692
3,50	6	92	54	48	36	SCD411-0350-2-3-135HA12-HP374	31132693
3,70	6	92	54	48	36	SCD411-0370-2-3-135HA12-HP374	31132695
4,00	6	102	64	58	36	SCD411-0400-2-3-135HA12-HP374	31132698
4,10	6	102	64	58	36	SCD411-0410-2-3-135HA12-HP374	31132699
4,20	6	102	64	58	36	SCD411-0420-2-3-135HA12-HP374	31132700
4,30	6	102	64	58	36	SCD411-0430-2-3-135HA12-HP374	31132701
4,50	6	102	64	58	36	SCD411-0450-2-3-135HA12-HP374	31132703
4,80	6	116	78	70	36	SCD411-0480-2-3-135HA12-HP374	31132706
5,00	6	116	78	70	36	SCD411-0500-2-3-135HA12-HP374	31132708
5,10	6	116	78	70	36	SCD411-0510-2-3-135HA12-HP374	31132709
5,20	6	116	78	70	36	SCD411-0520-2-3-135HA12-HP374	31132710
5,40	6	116	78	70	36	SCD411-0540-2-3-135HA12-HP374	31132712
5,50	6	116	78	70	36	SCD411-0550-2-3-135HA12-HP374	31132713
5,80	6	116	78	70	36	SCD411-0580-2-3-135HA12-HP374	31132716
6,00	6	116	78	70	36	SCD411-0600-2-3-135HA12-HP374	31132718
6,10	8	146	108	94	36	SCD411-0610-2-3-135HA12-HP374	31132719
6,20	8	146	108	94	36	SCD411-0620-2-3-135HA12-HP374	31132720
6,50	8	146	108	94	36	SCD411-0650-2-3-135HA12-HP374	31132723
6,80	8	146	108	94	36	SCD411-0680-2-3-135HA12-HP374	31132726
7,00	8	146	108	94	36	SCD411-0700-2-3-135HA12-HP374	31132728
7,50	8	146	108	94	36	SCD411-0750-2-3-135HA12-HP374	31132733
7,80	8	146	108	94	36	SCD411-0780-2-3-135HA12-HP374	31132736
8,00	8	146	108	94	36	SCD411-0800-2-3-135HA12-HP374	31132738
8,50	10	162	120	110	40	SCD411-0850-2-3-135HA12-HP374	31132743
9,00	10	162	120	110	40	SCD411-0900-2-3-135HA12-HP374	31132748
9,10	10	162	120	110	40	SCD411-0910-2-3-135HA12-HP374	31132749
9,50	10	162	120	110	40	SCD411-0950-2-3-135HA12-HP374	31132753
9,70	10	162	120	110	40	SCD411-0970-2-3-135HA12-HP374	31132755
9,80	10	162	120	110	40	SCD411-0980-2-3-135HA12-HP374	31132756
10,00	10	162	120	110	40	SCD411-1000-2-3-135HA12-HP374	31132758

MEGA-Speed-Drill-Inox | Punta elicoidale in metallo duro integrale SCD411 (12xD), adduzione interna del refrigerante

Dimensioni						Forma del codolo HA	
d ₁ m7	d ₂ h6	l ₁	l ₂	l ₃	l ₄	Specifiche	Codice
10,10	12	204	156	142	45	SCD411-1010-2-3-135HA12-HP374	31132759
10,20	12	204	156	142	45	SCD411-1020-2-3-135HA12-HP374	31132760
10,50	12	204	156	142	45	SCD411-1050-2-3-135HA12-HP374	31132763
11,00	12	204	156	142	45	SCD411-1100-2-3-135HA12-HP374	31132768
11,80	12	204	156	142	45	SCD411-1180-2-3-135HA12-HP374	31132776
12,00	12	204	156	142	45	SCD411-1200-2-3-135HA12-HP374	31132778
12,50	14	230	182	166	45	SCD411-1250-2-3-135HA12-HP374	31132780
12,80	14	230	182	166	45	SCD411-1280-2-3-135HA12-HP374	31132781
13,00	14	230	182	166	45	SCD411-1300-2-3-135HA12-HP374	31132782
13,50	14	230	182	166	45	SCD411-1350-2-3-135HA12-HP374	31132783
14,00	14	230	182	166	45	SCD411-1400-2-3-135HA12-HP374	31132785
15,00	16	260	208	192	48	SCD411-1500-2-3-135HA12-HP374	31132788
16,00	16	260	208	192	48	SCD411-1600-2-3-135HA12-HP374	31132793

Caratteristiche configurabili

**Diametro:**

Diametro a libera scelta a passi da 0,01 mm

**Forma del codolo:**

Forma del codolo: HB | HE

Specifiche:

SCD411-[diametro]-2-3-135[forma del codolo]12-HP374

Dimensioni serie configurabile

d ₁ min.	d ₁ max.	d ₂ h6	l ₁	l ₂	l ₃	l ₄
3,00	3,70	6	92	54	48	36
3,71	4,70	6	102	64	58	36
4,71	6,00	6	116	78	70	36
6,01	8,00	8	146	108	94	36
8,01	10,00	10	162	120	110	40
10,01	12,00	12	204	156	142	45
12,01	14,00	14	230	182	166	45
14,01	16,00	16	260	208	192	48
16,01	18,00	18	285	234	216	48
18,01	20,00	20	310	258	240	50

Esempio:

SCD411-0431-2-3-140HE12-HP374

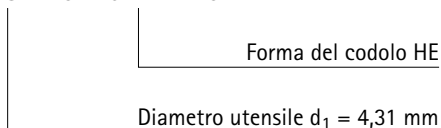

Misure in mm.

Per i parametri di lavorazione consigliati, vedere la fine del capitolo.

Versioni speciali e altri rivestimenti disponibili su richiesta.

MEGA-Speed-Drill-Iron

Punta elicoidale in metallo duro integrale
SCD421 (5xD), adduzione interna del refrigerante

Versione:

Diametro punta: 3,00 – 20,00 mm
Tolleranza di foratura: \geq IT 9
Materiale da taglio: HP238
Numero di taglienti: 2
Numero margini di guida: 3
Angolo tra taglienti: 130°
Angolo dell'elica: 30°

Applicazione

Per lavorazioni ad alta velocità.

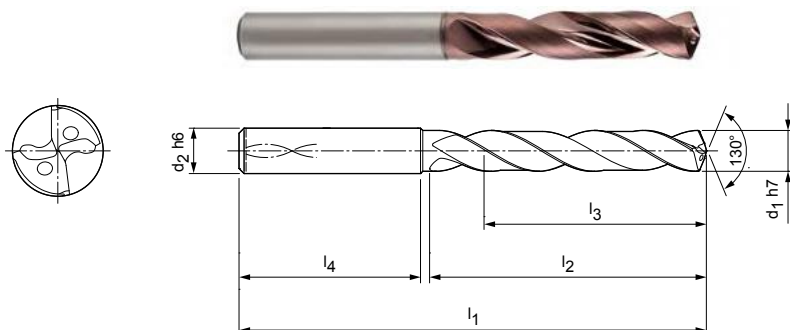

Serie selezionata per il magazzino con forma del codolo HA

Dimensioni						Forma del codolo HA	
d ₁ h7	d ₂ h6	l ₁	l ₂	l ₃	l ₄	Specifiche	Codice
5,00	6	82	44	35	36	SCD421-0500-2-3-130HA05-HP238	30488320
5,10	6	82	44	35	36	SCD421-0510-2-3-130HA05-HP238	30488321
6,00	6	82	44	35	36	SCD421-0600-2-3-130HA05-HP238	30488331
6,90	8	91	53	43	36	SCD421-0690-2-3-130HA05-HP238	30488340
7,00	8	91	53	43	36	SCD421-0700-2-3-130HA05-HP238	30488341
7,20	8	91	53	43	36	SCD421-0720-2-3-130HA05-HP238	30488343
8,10	10	103	61	49	40	SCD421-0810-2-3-130HA05-HP238	30488352
8,50	10	103	61	49	40	SCD421-0850-2-3-130HA05-HP238	30488356
9,00	10	103	61	49	40	SCD421-0900-2-3-130HA05-HP238	30488361
14,00	14	124	77	60	45	SCD421-1400-2-3-130HA05-HP238	30488397
17,50	18	143	93	71	48	SCD421-1750-2-3-130HA05-HP238	30488407

Caratteristiche configurabili



Diametro:

Diametro a libera scelta a passi da 0,01 mm



Forma del codolo:

Forma del codolo: HB | HE

Specifiche:

SCD421-[diametro]-2-3-130[forma del codolo]05-HP238

Dimensioni serie configurabile

d ₁ min.	d ₁ max.	d ₂ h6	l ₁	l ₂	l ₃	l ₄
3,00	3,70	6	66	28	23	36
3,71	4,79	6	74	36	29	36
4,80	6,00	6	82	44	35	36
6,01	8,00	8	91	53	43	36
8,01	10,00	10	103	61	49	40
10,01	12,00	12	118	71	56	45
12,01	14,00	14	124	77	60	45
14,01	16,00	16	133	83	63	48
16,01	18,00	18	143	93	71	48
18,01	20,00	20	153	101	77	50

Esempio:

SCD421-0431-2-3-130HE05-HP238

Forma del codolo HE

Diametro utensile d₁ = 4,31 mm

Misure in mm.

Per i parametri di lavorazione consigliati, vedere la fine del capitolo.

Versioni speciali e altri rivestimenti disponibili su richiesta.

MEGA-Drill-Alu

Punta elicoidale in metallo duro integrale
SCD131 (3xD), adduzione interna del refrigerante

Versione:

Diametro punta: 3,00 – 20,00 mm
Tolleranza di foratura: \geq IT 9
Materiale da taglio: HU630
Numero di taglienti: 2
Numero margini di guida: 2
Angolo tra taglienti: 140°
Angolo dell'elica: 30°

Applicazione

Idoneo come punta pilota per
MEGA-Deep-Drill-Alu.

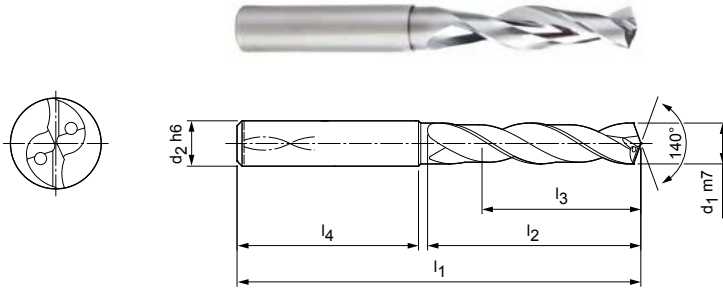

Serie selezionata per il magazzino con forma del codolo HA

Dimensioni						Forma del codolo HA	
d ₁ m7	d ₂ h6	l ₁	l ₂	l ₃	l ₄	Specifiche	Codice
6,50	8	79	34	24	36	SCD131-0650-2-2-140HA03-HU630	30394280
6,70	8	79	34	24	36	SCD131-0670-2-2-140HA03-HU630	30446643
7,00	8	79	34	24	36	SCD131-0700-2-2-140HA03-HU630	30391294
10,00	10	89	47	35	40	SCD131-1000-2-2-140HA03-HU630	30391297
11,00	12	102	55	40	45	SCD131-1100-2-2-140HA03-HU630	30391298
12,00	12	102	55	40	45	SCD131-1200-2-2-140HA03-HU630	30391299
13,20	14	107	60	43	45	SCD131-1320-2-2-140HA03-HU630	30694326
13,70	14	107	60	43	45	SCD131-1370-2-2-140HA03-HU630	30694329
16,00	16	115	65	45	48	SCD131-1600-2-2-140HA03-HU630	30391303

Caratteristiche configurabili



Diametro:

Diametro a libera scelta a passi da 0,01 mm



Forma del codolo:

Forma del codolo: HB | HE

Specifiche:

SCD131-[diametro]-2-2-140[forma del codolo]03-HU630

Dimensioni serie configurabile

d ₁ min.	d ₁ max.	d ₂ h6	l ₁	l ₂	l ₃	l ₄
3,00	3,50	6	62	20	14	36
3,51	4,50	6	66	24	17	36
4,51	6,00	6	66	28	20	36
6,01	7,97	8	79	34	24	36
7,98	8,00	8	79	41	29	36
8,01	10,00	10	89	47	35	40
10,01	12,00	12	102	55	40	45
12,01	14,00	14	107	60	43	45
14,01	16,00	16	115	65	45	48
16,01	18,00	18	123	73	51	48
18,01	20,00	20	131	79	55	50

Esempio:

SCD131-0431-2-3-140HE03-HU630

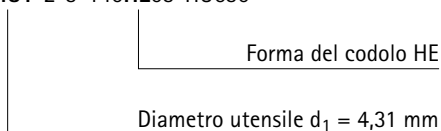

Misure in mm.

Per i parametri di lavorazione consigliati, vedere la fine del capitolo.

Versioni speciali e altri rivestimenti disponibili su richiesta.

MEGA-Drill-Alu

Punta elicoidale in metallo duro integrale
SCD131 (5xD), adduzione interna del refrigerante

Versione:

Diametro punta: 2,80 – 20,00 mm
Tolleranza di foratura: \geq IT 9
Materiale da taglio: HU630
Numero di taglienti: 2
Numero margini di guida: 2
Angolo tra taglienti: 140°
Angolo dell'elica: 30°

Applicazione

Idoneo come punta pilota per
MEGA-Deep-Drill-Alu.

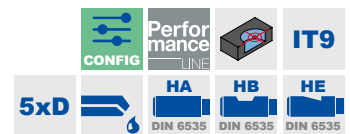
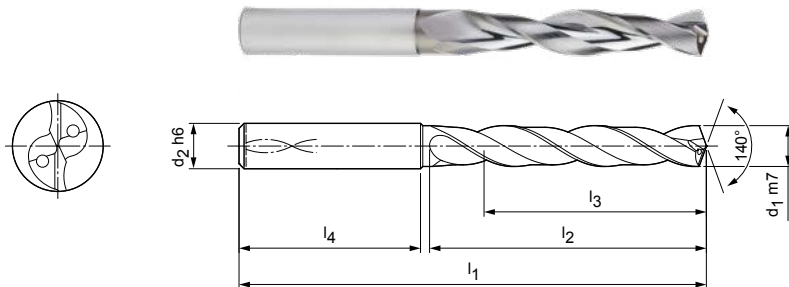

Serie selezionata per il magazzino con forma del codolo HA

Dimensioni						Forma del codolo HA	
d ₁ m7	d ₂ h6	l ₁	l ₂	l ₃	l ₄	Specifiche	Codice
3,00	6	66	28	23	36	SCD131-0300-2-2-140HA05-HU630	30391326
3,20	6	66	28	23	36	SCD131-0320-2-2-140HA05-HU630	30391328
3,30	6	66	28	23	36	SCD131-0330-2-2-140HA05-HU630	30391329
3,50	6	66	28	23	36	SCD131-0350-2-2-140HA05-HU630	30391331
3,70*	6	66	28	23	36	SCD131-0370-2-2-140HA05-HU630	30391333
3,90	6	74	36	29	36	SCD131-0390-2-2-140HA05-HU630	30391335
4,00	6	74	36	29	36	SCD131-0400-2-2-140HA05-HU630	30391336
4,10	6	74	36	29	36	SCD131-0410-2-2-140HA05-HU630	30391337
4,20	6	74	36	29	36	SCD131-0420-2-2-140HA05-HU630	30391338
4,30	6	74	36	29	36	SCD131-0430-2-2-140HA05-HU630	30391339
4,50	6	74	36	29	36	SCD131-0450-2-2-140HA05-HU630	30391341
4,60	6	74	36	29	36	SCD131-0460-2-2-140HA05-HU630	30391342
4,70	6	74	36	29	36	SCD131-0470-2-2-140HA05-HU630	30391343
5,00	6	82	44	35	36	SCD131-0500-2-2-140HA05-HU630	30391346
5,10	6	82	44	35	36	SCD131-0510-2-2-140HA05-HU630	30391347
5,20	6	82	44	35	36	SCD131-0520-2-2-140HA05-HU630	30391348
5,50	6	82	44	35	36	SCD131-0550-2-2-140HA05-HU630	30391351
5,60	6	82	44	35	36	SCD131-0560-2-2-140HA05-HU630	30391352
6,00	6	82	44	35	36	SCD131-0600-2-2-140HA05-HU630	30391356
6,10	8	91	53	43	36	SCD131-0610-2-2-140HA05-HU630	30391357
6,20	8	91	53	43	36	SCD131-0620-2-2-140HA05-HU630	30391358
6,30	8	91	53	43	36	SCD131-0630-2-2-140HA05-HU630	30391359
6,40	8	91	53	43	36	SCD131-0640-2-2-140HA05-HU630	30391360
6,50	8	91	53	43	36	SCD131-0650-2-2-140HA05-HU630	30391361
6,60	8	91	53	43	36	SCD131-0660-2-2-140HA05-HU630	30391362
6,80	8	91	53	43	36	SCD131-0680-2-2-140HA05-HU630	30391364
7,00	8	91	53	43	36	SCD131-0700-2-2-140HA05-HU630	30391366
7,40	8	91	53	43	36	SCD131-0740-2-2-140HA05-HU630	30391370
7,50	8	91	53	43	36	SCD131-0750-2-2-140HA05-HU630	30391371
7,60	8	91	53	43	36	SCD131-0760-2-2-140HA05-HU630	30391372
8,00	8	91	53	43	36	SCD131-0800-2-2-140HA05-HU630	30391376
8,40	10	103	61	49	40	SCD131-0840-2-2-140HA05-HU630	30391380
8,50	10	103	61	49	40	SCD131-0850-2-2-140HA05-HU630	30391381
8,73	10	103	61	49	40	SCD131-0873-2-2-140HA05-HU630	30451167
8,90	10	103	61	49	40	SCD131-0890-2-2-140HA05-HU630	30391385

MEGA-Drill-Alu | Punta elicoidale in metallo duro integrale SCD131 (5xD), adduzione interna del refrigerante

Dimensioni						Forma del codolo HA	
d ₁ m7	d ₂ h6	l ₁	l ₂	l ₃	l ₄	Specifiche	Codice
9,00	10	103	61	49	40	SCD131-0900-2-2-140HA05-HU630	30391386
9,20	10	103	61	49	40	SCD131-0920-2-2-140HA05-HU630	30391388
9,30*	10	103	61	49	40	SCD131-0930-2-2-140HA05-HU630	30391389
9,50	10	103	61	49	40	SCD131-0950-2-2-140HA05-HU630	30391391
9,60	10	103	61	49	40	SCD131-0960-2-2-140HA05-HU630	30391392
10,00	10	103	61	49	40	SCD131-1000-2-2-140HA05-HU630	30391396
10,20	12	118	71	56	45	SCD131-1020-2-2-140HA05-HU630	30391398
10,50	12	118	71	56	45	SCD131-1050-2-2-140HA05-HU630	30391401
10,80	12	118	71	56	45	SCD131-1080-2-2-140HA05-HU630	30391404
11,00	12	118	71	56	45	SCD131-1100-2-2-140HA05-HU630	30391406
11,50	12	118	71	56	45	SCD131-1150-2-2-140HA05-HU630	30391407
12,00	12	118	71	56	45	SCD131-1200-2-2-140HA05-HU630	30391408
12,50	14	124	77	60	45	SCD131-1250-2-2-140HA05-HU630	30391409
13,50	14	124	77	60	45	SCD131-1350-2-2-140HA05-HU630	30391411
14,00	14	124	77	60	45	SCD131-1400-2-2-140HA05-HU630	30391412
16,00	16	133	83	63	48	SCD131-1600-2-2-140HA05-HU630	30391418
20,00	20	153	101	77	50	SCD131-2000-2-2-140HA05-HU630	30446886

Caratteristiche configurabili

**Diametro:**

Diametro a libera scelta a passi da 0,01 mm

**Forma del codolo:**

Forma del codolo: HB | HE

Specifiche:

SCD131-[diametro]-2-2-140[forma del codolo]05-HU630

Dimensioni serie configurabile

d ₁ min.	d ₁ max.	d ₂ h6	l ₁	l ₂	l ₃	l ₄
2,80	3,70	6	66	28	23	36
3,71	4,70	6	74	36	29	36
4,71	6,00	6	82	44	35	36
6,01	8,00	8	91	53	43	36
8,01	10,00	10	103	61	49	40
10,01	12,00	12	118	71	56	45
12,01	14,00	14	124	77	60	45
14,01	16,00	16	133	83	63	48
16,01	18,00	18	143	93	71	48
18,01	20,00	20	153	101	77	50

Esempio:

SCD131-0431-2-2-140HE05-HU630

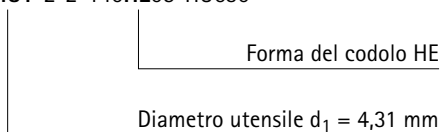

Misure in mm.

* Specifica per la prefabbricazione di fori da maschiare per maschi a filettare.

Per i parametri di lavorazione consigliati, vedere la fine del capitolo.

Versioni speciali e altri rivestimenti disponibili su richiesta.

MEGA-Drill-Alu

Punta elicoidale in metallo duro integrale
SCD131 (8xD), adduzione interna del refrigerante

Versione:

Diametro punta: 3,00 – 20,00 mm
Tolleranza di foratura: \geq IT 9
Materiale da taglio: HU630
Numero di taglienti: 2
Numero margini di guida: 2
Angolo tra taglienti: 140°
Angolo dell'elica: 30°

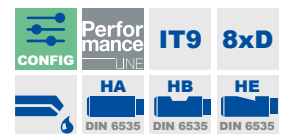
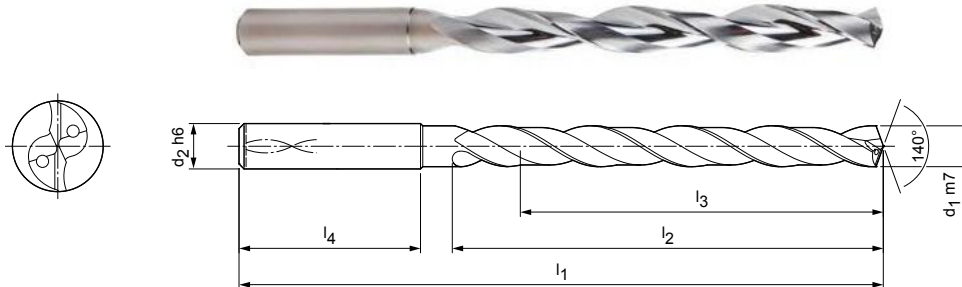

Serie selezionata per il magazzino con forma del codolo HA

Dimensioni						Forma del codolo HA	
d ₁ m7	d ₂ h6	l ₁	l ₂	l ₃	l ₄	Specifiche	Codice
3,00	6	72	34	29	36	SCD131-0300-2-2-140HA08-HU630	30391421
3,30	6	72	34	29	36	SCD131-0330-2-2-140HA08-HU630	30391424
3,50	6	72	34	29	36	SCD131-0350-2-2-140HA08-HU630	30391426
3,70	6	72	34	29	36	SCD131-0370-2-2-140HA08-HU630	30391428
4,00	6	81	43	36	36	SCD131-0400-2-2-140HA08-HU630	30391431
4,50	6	81	43	36	36	SCD131-0450-2-2-140HA08-HU630	30391436
5,00	6	95	57	48	36	SCD131-0500-2-2-140HA08-HU630	30391441
5,50	6	95	57	48	36	SCD131-0550-2-2-140HA08-HU630	30391446
6,50	8	114	76	64	36	SCD131-0650-2-2-140HA08-HU630	30391457
6,80	8	114	76	64	36	SCD131-0680-2-2-140HA08-HU630	30391460
7,00	8	114	76	64	36	SCD131-0700-2-2-140HA08-HU630	30391462
8,00	8	114	76	64	36	SCD131-0800-2-2-140HA08-HU630	30391472
9,30	10	142	95	80	40	SCD131-0930-2-2-140HA08-HU630	30391484
11,00	12	162	114	96	45	SCD131-1100-2-2-140HA08-HU630	30391500
12,00	12	162	114	96	45	SCD131-1200-2-2-140HA08-HU630	30391510

Caratteristiche configurabili



Diametro:

Diametro a libera scelta a passi da 0,01 mm



Forma del codolo:

Forma del codolo: HB | HE

Specifiche:

SCD131-[diametro]-2-2-140[forma del codolo]08-HU630

Dimensioni serie configurabile

d ₁ min.	d ₁ max.	d ₂ h6	l ₁	l ₂	l ₃	l ₄
3,00	3,70	6	72	34	29	36
3,71	4,70	6	81	43	36	36
4,71	6,00	6	95	57	48	36
6,01	8,00	8	114	76	64	36
8,01	10,00	10	142	95	80	40
10,01	12,00	12	162	114	96	45
12,01	14,00	14	178	133	112	45
14,01	16,00	16	203	152	128	48
16,01	18,00	18	222	171	144	48
18,01	20,00	20	243	190	160	50

Esempio:

SCD131-0431-2-2-140HE08-HU630

Forma del codolo HE

Diametro utensile d₁ = 4,31 mm

Misure in mm.

Per i parametri di lavorazione consigliati, vedere la fine del capitolo.
Versioni speciali e altri rivestimenti disponibili su richiesta.

MEGA-Drill-Alu

Punta elicoidale in metallo duro integrale
SCD131 (12xD), adduzione interna del refrigerante

Versione:

Diametro punta: 3,00 – 20,00 mm
Tolleranza di foratura: \geq IT 9
Materiale da taglio: HU630
Numero di taglienti: 2
Numero margini di guida: 2
Angolo tra taglienti: 140°
Angolo dell'elica: 30°

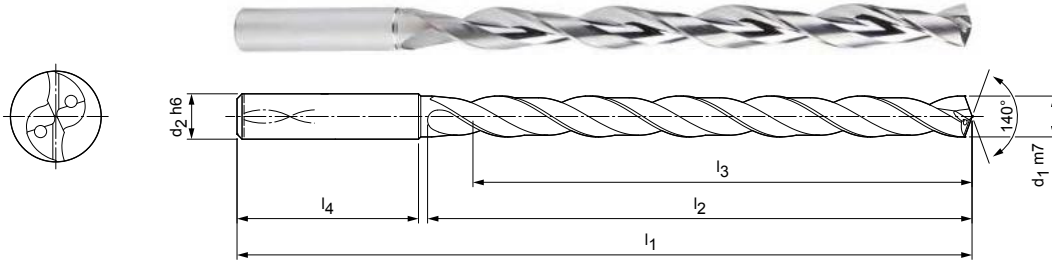

Serie selezionata per il magazzino con forma del codolo HA

Dimensioni						Forma del codolo HA	
d_1 m7	d_2 h6	l_1	l_2	l_3	l_4	Specifiche	Codice
3,00	6	92	54	48	36	SCD131-0300-2-2-140HA12-HU630	30391519
3,50	6	92	54	48	36	SCD131-0350-2-2-140HA12-HU630	30391524
4,00	6	102	64	58	36	SCD131-0400-2-2-140HA12-HU630	30391529
4,70	6	102	64	58	36	SCD131-0470-2-2-140HA12-HU630	30391536
5,00	6	116	78	70	36	SCD131-0500-2-2-140HA12-HU630	30391539
5,40	6	116	78	70	36	SCD131-0540-2-2-140HA12-HU630	30391543
5,50	6	116	78	70	36	SCD131-0550-2-2-140HA12-HU630	30391544
5,60	6	116	78	70	36	SCD131-0560-2-2-140HA12-HU630	30391545
6,00	6	116	78	70	36	SCD131-0600-2-2-140HA12-HU630	30391549
6,50	8	146	108	94	36	SCD131-0650-2-2-140HA12-HU630	30391554
6,60	8	146	108	94	36	SCD131-0660-2-2-140HA12-HU630	30391555
7,00	8	146	108	94	36	SCD131-0700-2-2-140HA12-HU630	30391558
8,00	8	146	108	94	36	SCD131-0800-2-2-140HA12-HU630	30391568
9,00	10	162	120	110	40	SCD131-0900-2-2-140HA12-HU630	30391577

Caratteristiche configurabili



Diametro:

Diametro a libera scelta a passi da 0,01 mm



Forma del codolo:

Forma del codolo: HB | HE

Specifiche:

SCD131-[diametro]-2-2-140[forma del codolo]12-HU630

Dimensioni serie configurabile

d_1 min.	d_1 max.	d_2 h6	l_1	l_2	l_3	l_4
3,00	3,70	6	92	54	48	36
3,71	4,70	6	102	64	58	36
4,71	6,00	6	116	78	70	36
6,01	8,00	8	146	108	94	36
8,01	10,00	10	162	120	110	40
10,01	12,00	12	204	156	142	45
12,01	14,00	14	230	182	166	45
14,01	16,00	16	260	208	192	48
16,01	18,00	18	285	234	216	48
18,01	20,00	20	310	258	240	50

Esempio:

SCD131-0431-2-2-140HE12-HU630

Forma del codolo HE

Diametro utensile $d_1 = 4,31$ mm

Misure in mm.

Per i parametri di lavorazione consigliati, vedere la fine del capitolo.
Versioni speciali e altri rivestimenti disponibili su richiesta.

MEGA-Drill-Composite-MD

Punta elicoidale in metallo duro integrale
SCD250 (5xD), adduzione esterna del refrigerante

Versione:

Diametro punta: 0,50 – 12,00 mm
Materiale da taglio: HC611/619/620
Numero di taglianti: 2
Numero margini di guida: 2
Angolo tra taglienti: 90°
Angolo dell'elica: 35°

Applicazione

CFRP con andamento fibre multidirezionale

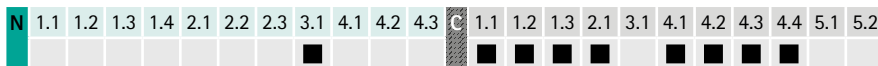
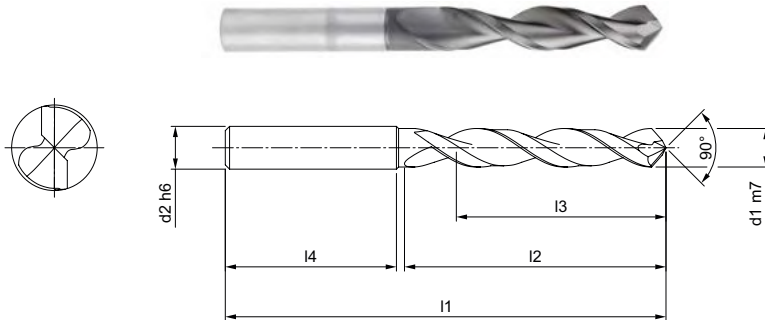

Dimensioni						Forma del codolo HA	
d ₁ m7	d ₂ h6	l ₁	l ₂	l ₃	l ₄	Specifiche	Codice
0,50	3	55	4,5	3	46	SCD250-0050-2-2-140HA05-HC620	30504673
2,00	3	68	14	11	51	SCD250-0200-2-2-140HA05-HC620	30504688
2,50	3	74	18	14	54	SCD250-0250-2-2-140HA05-HC620	30504693
3,00	6	66	28	23	36	SCD250-0300-2-2-090HA05-HC619	30401902
3,10	6	66	28	23	36	SCD250-0310-2-2-090HA05-HC619	30401903
3,20	6	66	28	23	36	SCD250-0320-2-2-090HA05-HC619	30401905
3,30	6	66	28	23	36	SCD250-0330-2-2-090HA05-HC619	30401906
3,80	6	66	28	23	36	SCD250-0380-2-2-090HA05-HC619	30401911
4,00	6	74	36	29	36	SCD250-0400-2-2-090HA05-HC619	30401913
4,10	6	74	36	29	36	SCD250-0410-2-2-090HA05-HC619	30401914
4,20	6	74	36	29	36	SCD250-0420-2-2-090HA05-HC619	30401915
4,30	6	74	36	29	36	SCD250-0430-2-2-090HA05-HC619	30401916
4,50	6	74	36	29	36	SCD250-0450-2-2-090HA05-HC619	30401918
4,80	6	74	36	29	36	SCD250-0480-2-2-090HA05-HC619	30401922
4,86	6	74	36	0	36	SCD250-0486-2-2-090HA05-HC619	30681789
5,00	6	82	44	35	36	SCD250-0500-2-2-090HA05-HC619	30401924
5,10	6	82	44	35	36	SCD250-0510-2-2-090HA05-HC619	30401925
5,20	6	82	44	35	36	SCD250-0520-2-2-090HA05-HC619	30401926
5,30	6	82	44	35	36	SCD250-0530-2-2-090HA05-HC619	30401927
5,50	6	82	44	35	36	SCD250-0550-2-2-090HA05-HC619	30401929
5,60	6	82	44	35	36	SCD250-0560-2-2-090HA05-HC619	30401930
5,80	6	82	44	35	36	SCD250-0580-2-2-090HA05-HC619	30401932
6,00	6	82	44	35	36	SCD250-0600-2-2-090HA05-HC619	30401934
6,50	8	91	53	43	36	SCD250-0650-2-2-090HA05-HC619	30401940
6,80	8	91	53	43	36	SCD250-0680-2-2-090HA05-HC619	30401943
7,00	8	91	53	43	36	SCD250-0700-2-2-090HA05-HC619	30401945
7,20	8	91	53	43	36	SCD250-0720-2-2-090HA05-HC619	30401947
7,50	8	91	53	43	36	SCD250-0750-2-2-090HA05-HC619	30401950
7,80	8	91	53	43	36	SCD250-0780-2-2-090HA05-HC619	30401953
8,00	8	91	53	43	36	SCD250-0800-2-2-090HA05-HC619	30401956
8,50	10	103	61	49	40	SCD250-0850-2-2-090HA05-HC611	30401961
8,80	10	103	61	49	40	SCD250-0880-2-2-090HA05-HC611	30401964
10,00	10	103	61	49	40	SCD250-1000-2-2-090HA05-HC611	30401977

MEGA-Drill-Composite-MD | Punta elicoidale in metallo duro integrale SCD250 (5xD), adduzione esterna del refrigerante

Dimensioni						Forma del codolo HA	
d ₁ m7	d ₂ h6	l ₁	l ₂	l ₃	l ₄	Specifiche	Codice
10,10	12	118	71	56	45	SCD250-1010-2-2-090HA05-HC611	30401978
10,40	12	118	71	56	45	SCD250-1040-2-2-090HA05-HC611	30401981
10,70	12	118	71	56	45	SCD250-1070-2-2-090HA05-HC611	30401984
12,00	12	118	71	56	45	SCD250-1200-2-2-090HA05-HC611	30401998

Caratteristiche configurabili

**Diametro:**

Diametro a libera scelta a passi da 0,01 mm

**Forma del codolo:**

Forma del codolo: HB | HE

Specifiche:

SCD250-[diametro]-2-2-090[forma del codolo]05-HC611

Dimensioni serie configurabile

d ₁ min.	d ₁ max.	d ₂ h6	l ₁	l ₂	l ₃	l ₄
3,00	3,99	6	66	28	23	36
4,00	4,99	6	74	36	29	36
5,00	6,00	6	82	44	35	36
6,01	8,00	8	91	53	43	36
8,01	10,00	10	103	61	49	40
10,01	12,00	12	118	71	56	45

Esempio:

SCD250-0431-2-2-090HE05-HC611

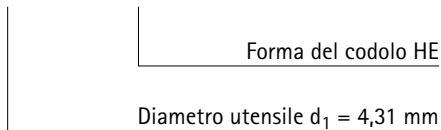

Misure in mm.

Per i parametri di lavorazione consigliati, vedere la fine del capitolo.

Versioni speciali e altri rivestimenti disponibili su richiesta.

MEGA-Drill-Composite-UDX

Punta elicoidale in metallo duro integrale
SCD270 (5xD), adduzione esterna del refrigerante

Versione:

Diametro punta:	3,00 – 12,00 mm
Tolleranza di foratura:	≥ IT 8
Materiale da taglio:	HC619
Numero di taglienti:	2
Numero margini di guida:	4
Angolo tra taglienti:	90°
Angolo dell'elica:	35°

Applicazione

Per tutti i materiali CFRP/ soluzione dei problemi in caso di situazioni di serraggio labile o componenti con pareti sottili.

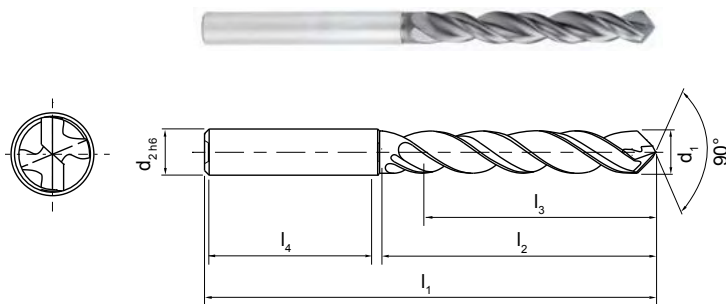

N	1.1	1.2	1.3	1.4	2.1	2.2	2.3	3.1	4.1	4.2	4.3	C	1.1	1.2	1.3	2.1	3.1	4.1	4.2	4.3	4.4	5.1	5.2	

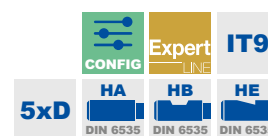

Serie selezionata per il magazzino con forma del codolo HA

Dimensioni						Forma del codolo HA	
d ₁ m7	d ₂ h6	l ₁	l ₂	l ₃	l ₄	Specifiche	Codice
3,30	6	66	26	20	36	SCD270-0330-2-2-090HA05-HC619	30402105
4,00	6	74	35	27	36	SCD270-0400-2-2-090HA05-HC619	30402112
4,394	6	74	35	27	36	SCD270-04394-2-2-090HA05-HC619	30634827
4,50	6	74	35	27	36	SCD270-0450-2-2-090HA05-HC619	30402117
5,00	6	82	44	35	36	SCD270-0500-2-2-090HA05-HC619	30402123

Caratteristiche configurabili



Diametro:

Diametro a libera scelta a passi da 0,01 mm



Forma del codolo:

Forma del codolo: HB | HE

Specifiche:

SCD270-[diametro]-2-2-090[forma del codolo]05-HC619

Dimensioni serie configurabile

d ₁ min.	d ₁ max.	d ₂ h6	l ₁	l ₂	l ₃	l ₄
3,00	3,99	6	66	26	20	36
4,00	4,99	6	74	35	27	36
5,00	6,00	6	82	44	35	36
6,01	8,00	8	91	52	40	36
8,01	10,00	10	103	60	45	40
10,01	12,00	12	118	70	52	45

Esempio:

SCD270-0431-2-2-090HE05-HC619

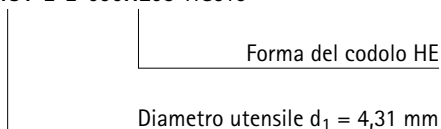

Misure in mm.

Per i parametri di lavorazione consigliati, vedere la fine del capitolo.

Versioni speciali e altri rivestimenti disponibili su richiesta.

MEGA-Drill-Composite-UDX

Punta elicoidale in metallo duro integrale
SCD271 (5xD), adduzione interna del refrigerante

Versione:

Diametro punta: 6,00 - 12,00 mm
Materiale da taglio: HC619
Numero di taglienti: 2
Numero margini di guida: 3
Angolo tra taglienti: 90°
Angolo dell'elica: 35°

Applicazione

Per tutti i materiali CFRP/ soluzione dei problemi in caso di situazioni di serraggio labile o componenti con pareti sottili.

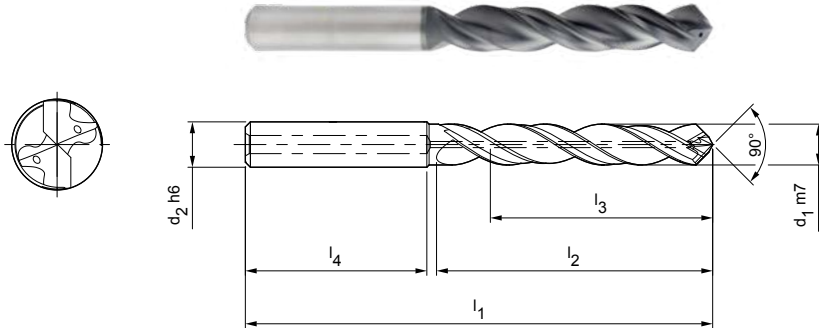

N	1.1	1.2	1.3	1.4	2.1	2.2	2.3	3.1	4.1	4.2	4.3	C	1.1	1.2	1.3	2.1	3.1	4.1	4.2	5.1	5.2	5.3	
								■				■		■	■	■							



Serie selezionata per il magazzino con forma del codolo HA

Dimensioni						Forma del codolo HA	
d1 m7	d2 h6	l1	l2	l3	l4	Specifiche	Codice
6,00	6	82	44	35	36	SCD271-0600-2-2-090HA05-HC619	30402197
8,00	8	91	52	40	36	SCD271-0800-2-2-090HA05-HC619	30402219
10,00	10	103	60	45	40	SCD271-1000-2-2-090HA05-HC611	30402240

Caratteristiche configurabili



Diametro:

Diametro a libera scelta a passi da 0,01 mm



Forma del codolo:

Forma del codolo: HB | HE

Specifiche:

SCD271-[diametro]-2-2-090[forma del codolo]05-HC619

Dimensioni serie configurabile

d1 min.	d1 max.	d2 h6	l1	l2	l3	l4
6,00	6,00	6	82	44	35	36
6,01	8,00	8	91	52	40	36
8,01	10,00	10	103	60	45	40
10,01	12,00	12	118	70	52	45

Esempio:

SCD271-0431-2-2-090HE05-HC619

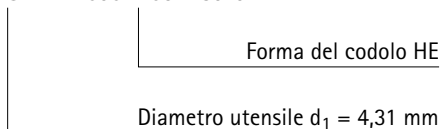

Misure in mm.

Per i parametri di lavorazione consigliati, vedere la fine del capitolo.

Versioni speciali e altri rivestimenti disponibili su richiesta.

MEGA-180°-Drill-Alu

Punta elicoidale in metallo duro integrale
SCD241 (3xD), adduzione interna del refrigerante

Versione:

Diametro punta: 3,00 – 20,00 mm
Tolleranza di foratura: \geq IT 9
Materiale da taglio: HU630
Numero di taglienti: 2
Numero margini di guida: 4
Angolo tra taglienti: 180°
Angolo dell'elica: 30°

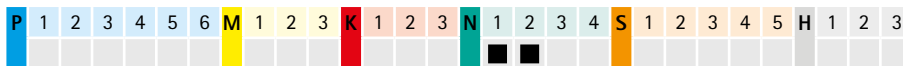
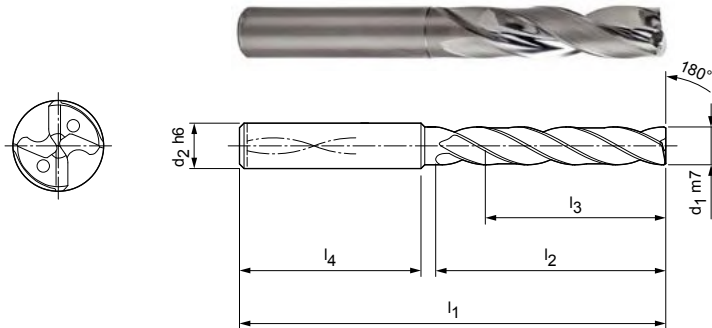

Serie selezionata per il magazzino con forma del codolo HA

Dimensioni						Forma del codolo HA	
d ₁ m7	d ₂ h6	l ₁	l ₂	l ₃	l ₄	Specifiche	Codice
3,00	6	62	20	14	36	SCD241-0300-2-4-180HA03-HU630	30382883
3,70	6	62	20	14	36	SCD241-0370-2-4-180HA03-HU630	30382890
4,00	6	66	24	17	36	SCD241-0400-2-4-180HA03-HU630	30382893
4,20	6	66	24	17	36	SCD241-0420-2-4-180HA03-HU630	30382895
4,30	6	66	24	17	36	SCD241-0430-2-4-180HA03-HU630	30382896
4,60	6	66	24	17	36	SCD241-0460-2-4-180HA03-HU630	30382899
5,00	6	66	28	20	36	SCD241-0500-2-4-180HA03-HU630	30382904
5,50	6	66	28	20	36	SCD241-0550-2-4-180HA03-HU630	30382909
5,56	6	66	28	20	36	SCD241-0556-2-4-180HA03-HU630	30463897
6,00	6	66	28	20	36	SCD241-0600-2-4-180HA03-HU630	30382915
6,50	8	79	34	24	36	SCD241-0650-2-4-180HA03-HU630	30382920
6,70	8	79	34	24	36	SCD241-0670-2-4-180HA03-HU630	30382922
7,00	8	79	34	24	36	SCD241-0700-2-4-180HA03-HU630	30382925
7,20	8	79	41	29	36	SCD241-0720-2-4-180HA03-HU630	30382927
7,40	8	79	41	29	36	SCD241-0740-2-4-180HA03-HU630	30382929
7,50	8	79	41	29	36	SCD241-0750-2-4-180HA03-HU630	30382930
7,80	8	79	41	29	36	SCD241-0780-2-4-180HA03-HU630	30382933
8,00	8	79	41	29	36	SCD241-0800-2-4-180HA03-HU630	30382935
8,50	10	89	47	35	40	SCD241-0850-2-4-180HA03-HU630	30382940
8,90	10	89	47	35	40	SCD241-0890-2-4-180HA03-HU630	30382944
9,00	10	89	47	35	40	SCD241-0900-2-4-180HA03-HU630	30382945
9,20	10	89	47	35	40	SCD241-0920-2-4-180HA03-HU630	30382947
9,80	10	89	47	35	40	SCD241-0980-2-4-180HA03-HU630	30382953
10,00	10	89	47	35	40	SCD241-1000-2-4-180HA03-HU630	30382955
11,00	12	100	53	38	45	SCD241-1100-2-4-180HA03-HU630	30382965
12,00	12	100	53	38	45	SCD241-1200-2-4-180HA03-HU630	30382975
13,00	14	105	58	41	45	SCD241-1300-2-4-180HA03-HU630	30382978
14,50	16	113	63	43	48	SCD241-1450-2-4-180HA03-HU630	30382982
17,00	18	121	71	49	48	SCD241-1700-2-4-180HA03-HU630	30382990
18,50	20	129	77	53	50	SCD241-1850-2-4-180HA03-HU630	30382994

MEGA-180°-Drill-Alu | Punta elicoidale in metallo duro integrale SCD241 (3xD), adduzione interna del refrigerante

Caratteristiche configurabili

**Diametro:**

Diametro a libera scelta a passi da 0,01 mm

**Forma del codolo:**

Forma del codolo: HB | HE

Specifiche:

SCD241-[diametro]-2-4-180[forma del codolo]03-HU630

Dimensioni serie configurabile

d ₁ min.	d ₁ max.	d ₂ h6	l ₁	l ₂	l ₃	l ₄
3,00	3,70	6	62	20	14	36
3,71	4,70	6	66	24	17	36
4,71	6,00	6	66	28	20	36
6,01	6,80	8	79	34	24	36
6,81	8,00	8	79	41	29	36
8,01	10,00	10	89	47	35	40
10,01	12,00	12	100	53	38	45
12,0	14,00	14	105	58	41	45
14,01	16,00	16	113	63	43	48
16,01	18,00	18	121	71	49	48
18,01	20,00	20	129	77	53	50

Esempio:

SCD241-0431-2-4-180HE03-HU630

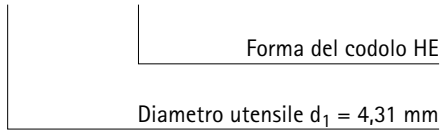

Misure in mm.

Per i parametri di lavorazione consigliati, vedere la fine del capitolo.

Versioni speciali e altri rivestimenti disponibili su richiesta.

MEGA-180°-Drill-Alu

Punta elicoidale in metallo duro integrale
SCD241 (5xD), adduzione interna del refrigerante

Versione:

Diametro punta: 3,00 – 20,00 mm
Tolleranza di foratura: \geq IT 9
Materiale da taglio: HU630
Numero di taglienti: 2
Numero margini di guida: 4
Angolo tra taglienti: 180°
Angolo dell'elica: 30°

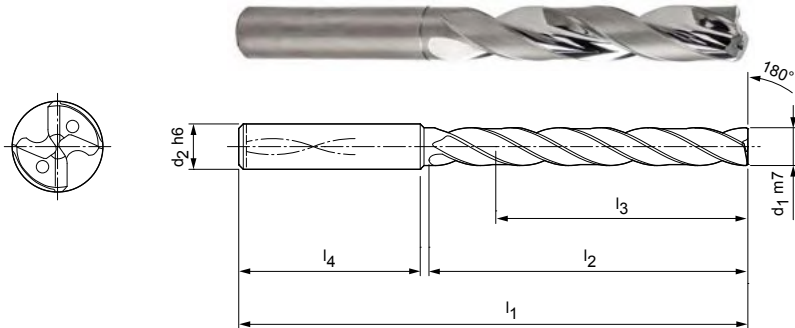
Serie selezionata per il magazzino con forma del codolo HA

Dimensioni						Forma del codolo HA	
d ₁ m7	d ₂ h6	l ₁	l ₂	l ₃	l ₄	Specifiche	Codice
3,00	6	66	28	23	36	SCD241-0300-2-4-180HA05-HU630	30383000
3,50	6	66	28	23	36	SCD241-0350-2-4-180HA05-HU630	30383005
4,00	6	74	36	29	36	SCD241-0400-2-4-180HA05-HU630	30383010
4,10	6	74	36	29	36	SCD241-0410-2-4-180HA05-HU630	30383011
4,80	6	82	44	35	36	SCD241-0480-2-4-180HA05-HU630	30383019
5,00	6	82	44	35	36	SCD241-0500-2-4-180HA05-HU630	30383021
5,60	6	82	44	35	36	SCD241-0560-2-4-180HA05-HU630	30383028
6,00	6	82	44	35	36	SCD241-0600-2-4-180HA05-HU630	30383032
6,50	8	91	53	43	36	SCD241-0650-2-4-180HA05-HU630	30383037
7,00	8	91	53	43	36	SCD241-0700-2-4-180HA05-HU630	30383042
7,50	8	91	53	43	36	SCD241-0750-2-4-180HA05-HU630	30383047
8,00	8	91	53	43	36	SCD241-0800-2-4-180HA05-HU630	30383052
8,20	10	103	61	49	40	SCD241-0820-2-4-180HA05-HU630	30383054
8,50	10	103	61	49	40	SCD241-0850-2-4-180HA05-HU630	30383057
9,00	10	103	61	49	40	SCD241-0900-2-4-180HA05-HU630	30383062
9,30	10	103	61	49	40	SCD241-0930-2-4-180HA05-HU630	30383066
10,00	10	103	61	49	40	SCD241-1000-2-4-180HA05-HU630	30383073
12,00	12	116	69	54	45	SCD241-1200-2-4-180HA05-HU630	30383093
13,00	14	122	75	58	45	SCD241-1300-2-4-180HA05-HU630	30383096
14,00	14	122	75	58	45	SCD241-1400-2-4-180HA05-HU630	30383099
15,00	16	131	81	61	48	SCD241-1500-2-4-180HA05-HU630	30383102
15,70	16	131	81	61	48	SCD241-1570-2-4-180HA05-HU630	31237410
20,00	20	151	99	75	50	SCD241-2000-2-4-180HA05-HU630	30383117

MEGA-180°-Drill-Alu | Punta elicoidale in metallo duro integrale SCD241 (5xD), adduzione interna del refrigerante

Caratteristiche configurabili

**Diametro:**

Diametro a libera scelta a passi da 0,01 mm

**Forma del codolo:**

Forma del codolo: HB | HE

Specifiche:

SCD241-[diametro]-2-4-180[forma del codolo]05-HU630

Dimensioni serie configurabile

d ₁ min.	d ₁ max.	d ₂ h6	l ₁	l ₂	l ₃	l ₄
3,00	3,70	6	66	28	23	36
3,71	4,70	6	74	36	29	36
4,71	6,00	6	82	44	35	36
6,01	8,00	8	91	53	43	36
8,01	10,00	10	103	61	49	40
10,01	12,00	12	116	69	54	45
12,01	14,00	14	122	75	58	45
14,01	16,00	16	131	81	61	48
16,01	18,00	18	141	91	69	48
18,01	20,00	20	151	99	75	50

Esempio:

SCD241-0431-2-4-180HE05-HU630

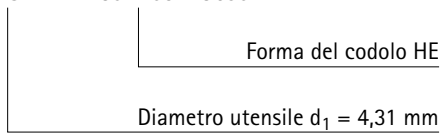

Misure in mm.

Per i parametri di lavorazione consigliati, vedere la fine del capitolo.

Versioni speciali e altri rivestimenti disponibili su richiesta.

ECU-G-Drill

Punta in metallo duro integrale, scanalatura dritta
SCD211 (5xD), adduzione interna del refrigerante

Versione:

Diametro punta: 4,80 – 7,50 mm

Tolleranza di foratura: \geq IT 9

Materiale da taglio: HU610

Numero di taglienti: 2

Numero margini di guida: 4

Angolo tra taglienti: 130°

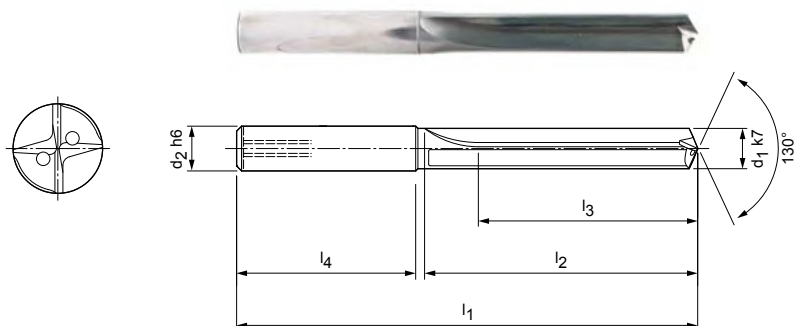
Serie selezionata per il magazzino con forma del codolo HA

Dimensioni						Forma del codolo HA	
d_1 k7	d_2 h6	l_1	l_2	l_3	l_4	Specifiche	Codice
4,80	6	82	44	35	36	SCD211-0480-2-4-130HA05-HU610	30392622
5,50	6	82	44	35	36	SCD211-0550-2-4-130HA05-HU610	30392630
5,70	6	82	44	35	36	SCD211-0570-2-4-130HA05-HU610	30392632
5,80	6	82	44	35	36	SCD211-0580-2-4-130HA05-HU610	30392633
6,80	8	91	53	43	36	SCD211-0680-2-4-130HA05-HU610	30392643
7,40	8	91	53	43	36	SCD211-0740-2-4-130HA05-HU610	30392649
7,50	8	91	53	43	36	SCD211-0750-2-4-130HA05-HU610	30392650

Caratteristiche configurabili

Forma del codolo:

Forma del codolo: HB | HE

Specifiche:

SCD211-0430-2-4-130[forma del codolo]05-HU610

Esempio:

SCD211-0430-3-3-140HE05-HU610

Forma del codolo HE

Misure in mm.

Per i parametri di lavorazione consigliati, vedere la fine del capitolo.

Versioni speciali e altri rivestimenti disponibili su richiesta.

ECU-G-Drill

Punta in metallo duro integrale, scanalatura dritta
SCD211 (8xD), adduzione interna del refrigerante

Versione:

Diametro punta: 5,80 – 11,60 mm
Tolleranza di foratura: \geq IT 9
Materiale da taglio: HU610
Numero di taglienti: 2
Numero margini di guida: 4
Angolo tra taglienti: 130°

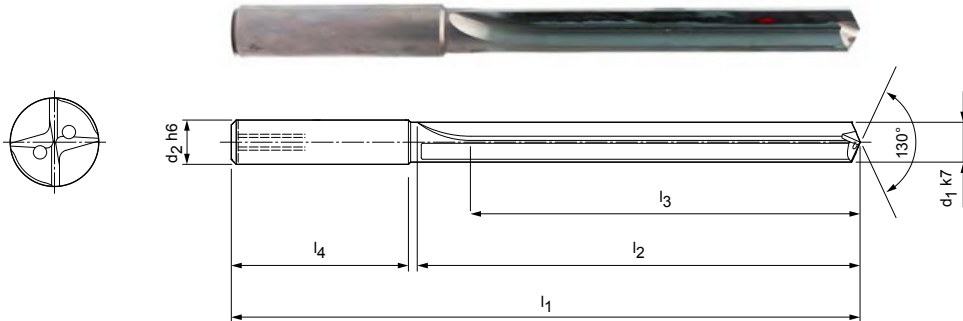

Serie selezionata per il magazzino con forma del codolo HA

Dimensioni						Forma del codolo HA	
d_1 k7	d_2 h6	l_1	l_2	l_3	l_4	Specifiche	Codice
5,80	6	95	57	48	36	SCD211-0580-2-4-130HA08-HU610	30392739
11,60	12	162	114	96	45	SCD211-1160-2-4-130HA08-HU610	30392797

Caratteristiche configurabili



Forma del codolo:
Forma del codolo: HB | HE



Specifiche:

SCD211-0430-2-4-130[forma del codolo]08-HU610

Esempio:

SCD211-0430-3-3-140HE08-HU610

Forma del codolo HE

Misure in mm.

Per i parametri di lavorazione consigliati, vedere la fine del capitolo.

Versioni speciali e altri rivestimenti disponibili su richiesta.

Parametri di lavorazione consigliati per punte in metallo duro integrale

Avanzamento e velocità di taglio

Tritan-Drill-Uni-Plus | SCD631

GTM*		Materiale	Resistenza/durezza [N/mm ²] [HRC]
P	P1	P1.1 Acciai da costruzione, automatici, da cementazione e da bonifica, non legati	< 700
		P1.2 Acciai da costruzione, automatici, da cementazione e da bonifica, non legati	< 1.200
	P2	P2.1 Acciai da niturazione, da cementazione e da bonifica, legati	< 900
		P2.2 Acciai da niturazione, da cementazione e da bonifica, legati	< 1.400
	P3	P3.1 Acciai per utensili, per cuscinetti volventi, armonici e per lavorazioni veloci**	< 800
		P3.2 Acciai per utensili, per cuscinetti volventi, armonici e per lavorazioni veloci**	< 1.000
		P3.3 Acciai per utensili, per cuscinetti volventi, armonici e per lavorazioni veloci**	< 1.500
	P5	P5.1 Acciaio fuso	
M	M1	M1.1 Acciai inossidabili, austenitici	< 700
		M1.2 Acciai inossidabili, ferritici/austenitici (Duplex)	< 1.000
K	K1	K1.1 Ghisa con grafite lamellare (ghisa grigia), GJL	< 300
		K2.1 Ghisa con grafite sferoidale, GJS	< 500
		K2.2 Ghisa con grafite sferoidale, GJS	≤ 800
		K2.3 Ghisa con grafite sferoidale, GJS	> 800
	K3	K3.1 Ghisa con grafite vermicolare, GJV; acciaio fuso malleabile, GJM	< 500
		K3.2 Ghisa con grafite vermicolare, GJV; acciaio fuso malleabile, GJM	> 500
N	N1	N1.1 Alluminio, non legato e legato < 3% Si	
		N1.2 Alluminio, legato ≤ 7% Si	
		N1.3 Alluminio, legato > 7-12% Si	
		N1.4 Alluminio, legato > 12% Si	
	N2	N2.1 Rame, non legato e bassolegato	< 300
		N2.2 Rame, legato	> 300
		N2.3 Ottone, bronzo, ghisa rossa	< 1.200

MEGA-Speed-Drill-Uni | SCD221

GTM*		Materiale	Resistenza/durezza [N/mm ²] [HRC]
P	P1	P1.1 Acciai da costruzione, automatici, da cementazione e da bonifica, non legati	< 700
		P1.2 Acciai da costruzione, automatici, da cementazione e da bonifica, non legati	< 1.200
	P2	P2.1 Acciai da niturazione, da cementazione e da bonifica, legati	< 900
		P2.2 Acciai da niturazione, da cementazione e da bonifica, legati	< 1.400
	P3	P3.1 Acciai per utensili, per cuscinetti volventi, armonici e per lavorazioni veloci**	< 800
		P3.2 Acciai per utensili, per cuscinetti volventi, armonici e per lavorazioni veloci**	< 1.000
		P3.3 Acciai per utensili, per cuscinetti volventi, armonici e per lavorazioni veloci**	< 1.500
	P4	P4.1 Acciai inossidabili, ferritici e martensitici	
	P5	P5.1 Acciaio fuso	
	P6	P6.1 Acciaio fuso, ferritico e martensitico	
K	K1	K1.1 Ghisa con grafite lamellare (ghisa grigia), GJL	< 300
		K2.1 Ghisa con grafite sferoidale, GJS	< 500
		K2.2 Ghisa con grafite sferoidale, GJS	≤ 800
		K2.3 Ghisa con grafite sferoidale, GJS	> 800
	K3	K3.1 Ghisa con grafite vermicolare, GJV; acciaio fuso malleabile, GJM	< 500
		K3.2 Ghisa con grafite vermicolare, GJV; acciaio fuso malleabile, GJM	> 500

* Gruppi di materiale MAPAL

** Qualora la somma dei componenti di lega Cr, Mo, Ni, V, W equivalesse a > 8%, selezionare il gruppo di materiale MAPAL immediatamente superiore.

	Velocità di taglio v_c [m/min]				Avanzamento f [mm] con diametro punta					
	Adduzione interna del refrigerante	Raffreddamento esterno	MQL	Aria	4,00	5,50	7,50	10,50	14,50	20,00
	115	105	105		0,22	0,27	0,34	0,42	0,51	0,59
	105	85	85		0,27	0,34	0,42	0,53	0,64	0,74
	115	100	100		0,25	0,32	0,40	0,50	0,60	0,70
	80	70	70		0,21	0,26	0,32	0,40	0,48	0,55
	85	75	75		0,23	0,29	0,36	0,45	0,54	0,63
	70	65	65		0,19	0,24	0,30	0,37	0,44	0,51
	70	50	60		0,16	0,19	0,24	0,29	0,34	0,40
	115	100	100		0,25	0,32	0,40	0,50	0,60	0,70
	55	35	35		0,11	0,14	0,18	0,22	0,27	0,31
	140	100	100	100	0,31	0,41	0,53	0,68	0,84	0,98
	185	115	140	140	0,30	0,39	0,50	0,64	0,78	0,91
	115	85	85		0,27	0,35	0,44	0,55	0,67	0,78
	70	45	60		0,14	0,18	0,22	0,28	0,33	0,38
	105	90	90		0,29	0,37	0,47	0,59	0,72	0,84
	90	80	80		0,25	0,31	0,38	0,48	0,57	0,66
	345	230	290		0,22	0,27	0,34	0,42	0,51	0,59
	290	205	230		0,27	0,35	0,44	0,55	0,67	0,78
	255	175	205		0,27	0,35	0,44	0,55	0,67	0,78
	205	140	175		0,27	0,35	0,44	0,55	0,67	0,78
	140	105			0,20	0,26	0,33	0,41	0,50	0,58
	230	185	185	140	0,31	0,41	0,53	0,68	0,84	0,98

	Velocità di taglio v_c [m/min]				Avanzamento f [mm] con diametro punta					
	Adduzione interna del refrigerante	Raffreddamento esterno	MQL	Aria	3,00	4,50	6,50	9,50	14,00	20,00
	170	155	155		0,11	0,14	0,18	0,23	0,30	0,36
	155	130	130		0,14	0,18	0,22	0,29	0,37	0,45
	170	145	145		0,13	0,17	0,21	0,27	0,35	0,43
	120	100	100		0,11	0,14	0,17	0,22	0,28	0,34
	130	110	110		0,11	0,15	0,19	0,25	0,32	0,38
	115	100	95		0,10	0,14	0,17	0,22	0,28	0,35
	100	75	85		0,10	0,13	0,16	0,20	0,26	0,31
	100	75	85		0,08	0,10	0,13	0,16	0,21	0,25
	170	145	145		0,13	0,17	0,21	0,27	0,35	0,43
	100	75	85		0,08	0,10	0,13	0,16	0,21	0,25
	150	105	105	105	0,13	0,19	0,26	0,35	0,45	0,54
	200	125	150	150	0,13	0,18	0,25	0,33	0,42	0,50
	125	95	95		0,12	0,16	0,22	0,28	0,36	0,43
	75	50	65		0,09	0,12	0,15	0,19	0,24	0,28
	115	100	100		0,13	0,18	0,23	0,31	0,39	0,46
	100	90	90		0,11	0,15	0,19	0,25	0,31	0,36

I parametri di lavorazione indicati sono valori orientativi.

I dati ottimali per la specifica applicazione devono essere rilevati eseguendo diversi tentativi o durante l'effettiva lavorazione.

Parametri di lavorazione consigliati per punte in metallo duro integrale

Avanzamento e velocità di taglio

ECU-Drill-Uni | SCD350, 351

GTM*		Materiale	Resistenza/durezza [N/mm ²] [HRC]
P	P1	P1.1 Acciai da costruzione, automatici, da cementazione e da bonifica, non legati	< 700
		P1.2 Acciai da costruzione, automatici, da cementazione e da bonifica, non legati	< 1.200
	P2	P2.1 Acciai da niturazione, da cementazione e da bonifica, legati	< 900
		P2.2 Acciai da niturazione, da cementazione e da bonifica, legati	< 1.400
	P3	P3.1 Acciai per utensili, per cuscinetti volventi, armonici e per lavorazioni veloci**	< 800
		P3.2 Acciai per utensili, per cuscinetti volventi, armonici e per lavorazioni veloci**	< 1.000
		P3.3 Acciai per utensili, per cuscinetti volventi, armonici e per lavorazioni veloci**	< 1.500
	P5	P5.1 Acciaio fuso	
M	M1	M1.1 Acciai inossidabili, austenitici	< 700
		M1.2 Acciai inossidabili, ferritici/austenitici (Duplex)	< 1.000
	M2	M2.1 Acciaio fuso inossidabile, austenitico	< 700
	M3	M3.1 Acciaio fuso inossidabile, ferritico/austenitico (Duplex)	< 1.000
K	K2	K2.1 Ghisa con grafite sferoidale, GJS	< 500
		K2.2 Ghisa con grafite sferoidale, GJS	≤ 800
		K2.3 Ghisa con grafite sferoidale, GJS	> 800

MEGA-Drill-Steel-Plus | SCD600, 601

GTM*		Materiale	Resistenza/durezza [N/mm ²] [HRC]
P	P1	P1.1 Acciai da costruzione, automatici, da cementazione e da bonifica, non legati	< 700
		P1.2 Acciai da costruzione, automatici, da cementazione e da bonifica, non legati	< 1.200
	P2	P2.1 Acciai da niturazione, da cementazione e da bonifica, legati	< 900
		P2.2 Acciai da niturazione, da cementazione e da bonifica, legati	< 1.400
	P3	P3.1 Acciai per utensili, per cuscinetti volventi, armonici e per lavorazioni veloci**	< 800
		P3.2 Acciai per utensili, per cuscinetti volventi, armonici e per lavorazioni veloci**	< 1.000
		P3.3 Acciai per utensili, per cuscinetti volventi, armonici e per lavorazioni veloci**	< 1.500
	P4	P4.1 Acciai inossidabili, ferritici e martensitici	
	P5	P5.1 Acciaio fuso	
	P6	P6.1 Acciaio fuso, ferritico e martensitico	
K	K1	K1.1 Ghisa con grafite lamellare (ghisa grigia), GJL	< 300
		K2.1 Ghisa con grafite sferoidale, GJS	< 500
	K2	K2.2 Ghisa con grafite sferoidale, GJS	≤ 800
		K2.3 Ghisa con grafite sferoidale, GJS	> 800
	K3	K3.1 Ghisa con grafite vermicolare, GJV; acciaio fuso malleabile, GJM	< 500
		K3.2 Ghisa con grafite vermicolare, GJV; acciaio fuso malleabile, GJM	> 500
H	H1	H1.1 Acciaio temprato/acciaio fuso	< 44
		H1.2 Acciaio temprato/acciaio fuso	< 55

* Gruppi di materiale MAPAL

** Qualora la somma dei componenti di lega Cr, Mo, Ni, V, W equivalesse a > 8%, selezionare il gruppo di materiale MAPAL immediatamente superiore.

	Velocità di taglio v_c [m/min]				Avanzamento f [mm] con diametro punta					
	Adduzione interna del refrigerante	Raffreddamento esterno	MQL	Aria	1,00	1,82	3,31	6,03	10,99	20,00
	75	70	70		0,03	0,05	0,07	0,10	0,16	0,21
	70	55	55		0,04	0,06	0,08	0,13	0,20	0,27
	75	65	65		0,04	0,05	0,08	0,12	0,18	0,25
	55	45	45		0,04	0,05	0,07	0,10	0,15	0,20
	55	50	50		0,03	0,05	0,07	0,11	0,17	0,23
	45	40	40		0,03	0,04	0,06	0,09	0,14	0,18
	45	35	40		0,03	0,04	0,05	0,07	0,11	0,14
	75	65	65		0,04	0,05	0,08	0,12	0,18	0,25
	45	30	30		0,03	0,04	0,06	0,09	0,14	0,19
	45	25	25		0,02	0,03	0,05	0,08	0,12	0,16
	45	30	30		0,03	0,04	0,06	0,09	0,14	0,19
	45	25	25		0,02	0,03	0,05	0,08	0,12	0,16
	120	75	90	90	0,05	0,07	0,12	0,19	0,30	0,41
	75	55	55		0,04	0,07	0,11	0,17	0,26	0,35

	Velocità di taglio v_c [m/min]				Avanzamento f [mm] con diametro punta					
	Adduzione interna del refrigerante	Raffreddamento esterno	MQL	Aria	3,00	4,50	6,50	9,50	14,00	20,00
	110	100	100		0,10	0,13	0,17	0,22	0,28	0,33
	100	85	85		0,12	0,16	0,21	0,27	0,34	0,41
	110	95	95		0,11	0,15	0,20	0,26	0,33	0,38
	75	65	65		0,10	0,13	0,16	0,21	0,26	0,30
	85	70	70		0,10	0,14	0,18	0,23	0,29	0,35
	65	60	60		0,09	0,12	0,15	0,19	0,24	0,28
	65	50	55		0,07	0,09	0,12	0,15	0,19	0,22
	65	50	55		0,07	0,09	0,12	0,15	0,19	0,23
	110	95	95		0,11	0,15	0,20	0,26	0,33	0,38
	65	50	55		0,07	0,09	0,12	0,15	0,19	0,23
	120	85	85	85	0,13	0,19	0,26	0,35	0,45	0,54
	160	100	120	120	0,13	0,18	0,25	0,33	0,42	0,50
	100	75	75		0,12	0,16	0,22	0,28	0,36	0,43
	60	40	50		0,09	0,12	0,15	0,19	0,24	0,28
	90	80	80		0,13	0,18	0,23	0,31	0,39	0,46
	80	70	70		0,11	0,15	0,19	0,25	0,31	0,36
	90	90	90		0,09	0,12	0,15	0,19	0,24	0,28
	25	25	25		0,05	0,06	0,08	0,11	0,14	0,16

I parametri di lavorazione indicati sono valori orientativi.

I dati ottimali per la specifica applicazione devono essere rilevati eseguendo diversi tentativi o durante l'effettiva lavorazione.

Parametri di lavorazione consigliati per punte in metallo duro integrale

Avanzamento e velocità di taglio

MEGA-Quadro-Drill-Plus | SCD610, 611

GTM*		Materiale	Resistenza/durezza [N/mm ²] [HRC]
P	P1	P1.1 Acciai da costruzione, automatici, da cementazione e da bonifica, non legati	< 700
		P1.2 Acciai da costruzione, automatici, da cementazione e da bonifica, non legati	< 1.200
	P2	P2.1 Acciai da niturazione, da cementazione e da bonifica, legati	< 900
		P2.2 Acciai da niturazione, da cementazione e da bonifica, legati	< 1.400
	P3	P3.1 Acciai per utensili, per cuscinetti volventi, armonici e per lavorazioni veloci*	< 800
		P3.2 Acciai per utensili, per cuscinetti volventi, armonici e per lavorazioni veloci*	< 1.000
		P3.3 Acciai per utensili, per cuscinetti volventi, armonici e per lavorazioni veloci*	< 1.500
	P5	P5.1 Acciaio fuso	
K	K1	K1.1 Ghisa con grafite lamellare (ghisa grigia), GJL	< 300
		K2.1 Ghisa con grafite sferoidale, GJS	< 500
	K2	K2.2 Ghisa con grafite sferoidale, GJS	≤ 800
		K2.3 Ghisa con grafite sferoidale, GJS	> 800
	K3	K3.1 Ghisa con grafite vermicolare, GJV; acciaio fuso malleabile, GJM	< 500
		K3.2 Ghisa con grafite vermicolare, GJV; acciaio fuso malleabile, GJM	> 500

MICRO-Drill-Steel | SCD371

GTM*		Materiale	Resistenza/durezza [N/mm ²] [HRC]
P	P1	P1.1 Acciai da costruzione, automatici, da cementazione e da bonifica, non legati	< 700
		P1.2 Acciai da costruzione, automatici, da cementazione e da bonifica, non legati	< 1.200
	P2	P2.1 Acciai da niturazione, da cementazione e da bonifica, legati	< 900
		P2.2 Acciai da niturazione, da cementazione e da bonifica, legati	< 1.400
	P3	P3.1 Acciai per utensili, per cuscinetti volventi, armonici e per lavorazioni veloci*	< 800
		P3.2 Acciai per utensili, per cuscinetti volventi, armonici e per lavorazioni veloci*	< 1.000
		P3.3 Acciai per utensili, per cuscinetti volventi, armonici e per lavorazioni veloci*	< 1.500
	P5	P5.1 Acciaio fuso	
M	M1	M1.1 Acciai inossidabili, austenitici	< 700
		M1.2 Acciai inossidabili, ferritici/austenitici (Duplex)	< 1000
K	K1	K1.1 Ghisa con grafite lamellare (ghisa grigia), GJL	< 300
		K2.1 Ghisa con grafite sferoidale, GJS	< 500
	K2	K2.2 Ghisa con grafite sferoidale, GJS	≤ 800
		K2.3 Ghisa con grafite sferoidale, GJS	> 800
	K3	K3.1 Ghisa con grafite vermicolare, GJV; acciaio fuso malleabile, GJM	< 500
		K3.2 Ghisa con grafite vermicolare, GJV; acciaio fuso malleabile, GJM	> 500

MEGA-Drill-Hardened | SCD141

GTM*		Materiale	Resistenza/durezza [N/mm ²] [HRC]
H	H1	H1.1 Acciaio temprato/acciaio fuso	< 44
		H1.2 Acciaio temprato/acciaio fuso	< 55
	H2	H2.1 Acciaio temprato/acciaio fuso	< 60
		H2.2 Acciaio temprato/acciaio fuso	< 65
		H2.3 Acciaio temprato/acciaio fuso	< 68

* Gruppi di materiale MAPAL

** Qualora la somma dei componenti di lega Cr, Mo, Ni, V, W equivalesse a > 8%, selezionare il gruppo di materiale MAPAL immediatamente superiore.

	Velocità di taglio v_c [m/min]				Avanzamento f [mm] con diametro punta					
	Adduzione interna del refrigerante	Raffreddamento esterno	MQL	Aria	4,00	5,50	7,50	10,50	14,50	20,00
	110	100	100		0,10	0,13	0,17	0,22	0,28	0,33
	100	85	85		0,12	0,16	0,21	0,27	0,34	0,41
	110	95	95		0,11	0,15	0,20	0,26	0,33	0,38
	75	65	65		0,10	0,13	0,16	0,21	0,26	0,30
	85	70	70		0,10	0,14	0,18	0,23	0,29	0,35
	65	60	60		0,09	0,12	0,15	0,19	0,24	0,28
	65	50	55		0,07	0,09	0,12	0,15	0,19	0,22
	110	95	95		0,11	0,15	0,20	0,26	0,33	0,38
	130	95	95	95	0,13	0,19	0,26	0,35	0,45	0,54
	175	110	130	130	0,13	0,18	0,25	0,33	0,42	0,50
	110	85	85		0,12	0,16	0,22	0,28	0,36	0,43
	65	45	55		0,09	0,12	0,15	0,19	0,24	0,28
	100	90	90		0,13	0,18	0,23	0,31	0,39	0,46
	90	75	75		0,11	0,15	0,19	0,25	0,31	0,36

	Velocità di taglio v_c [m/min]				Avanzamento f [mm] con diametro punta					
	Adduzione interna del refrigerante	Raffreddamento esterno	MQL	Aria	4,00	5,50	7,50	10,50	14,50	20,00
	80	70	70		0,04	0,04	0,05	0,06	0,07	0,08
	70	60	60		0,04	0,05	0,06	0,07	0,08	0,10
	80	70	70		0,04	0,05	0,06	0,07	0,08	0,09
	55	50	50		0,04	0,05	0,05	0,06	0,07	0,08
	60	50	50		0,04	0,04	0,05	0,06	0,07	0,08
	50	45	45		0,04	0,04	0,04	0,05	0,06	0,07
	50	35	40		0,03	0,04	0,04	0,05	0,05	0,06
	80	70	70		0,04	0,05	0,06	0,07	0,08	0,09
	40	25	25		0,03	0,03	0,03	0,04	0,05	0,06
	95	70	70	70	0,03	0,04	0,05	0,06	0,08	0,11
	130	80	95	95	0,04	0,05	0,06	0,07	0,09	0,11
	80	60	60		0,04	0,05	0,05	0,07	0,08	0,10
	70	65	65		0,04	0,05	0,06	0,07	0,09	0,11
	65	55	55		0,04	0,05	0,06	0,07	0,08	0,09

	Velocità di taglio v_c [m/min]				Avanzamento f [mm] con diametro punta					
	Adduzione interna del refrigerante	Raffreddamento esterno	MQL	Aria	2,50	3,62	5,25	7,61	11,04	16,00
	80	80	80		0,07	0,09	0,11	0,02	0,19	0,20
	30	30	30		0,05	0,06	0,08	0,10	0,13	0,16
		30	30		0,04	0,05	0,07	0,09	0,11	0,13
		20	20		0,03	0,04	0,05	0,06	0,08	0,09
		15	15		0,03	0,04	0,05	0,06	0,08	0,09

I parametri di lavorazione indicati sono valori orientativi.

I dati ottimali per la specifica applicazione devono essere rilevati eseguendo diversi tentativi o durante l'effettiva lavorazione.

Parametri di lavorazione consigliati per punte in metallo duro integrale

Avanzamento e velocità di taglio

Tritan-Drill-Steel | SCD661

GTM*		Materiale	Resistenza/durezza [N/mm ²] [HRC]
P	P1	P1.1 Acciai da costruzione, automatici, da cementazione e da bonifica, non legati	< 700
		P1.2 Acciai da costruzione, automatici, da cementazione e da bonifica, non legati	< 1.200
	P2	P2.1 Acciai da nitrazione, da cementazione e da bonifica, legati	< 900
		P2.2 Acciai da nitrazione, da cementazione e da bonifica, legati	< 1.400
	P3	P3.1 Acciai per utensili, per cuscinetti volventi, armonici e per lavorazioni veloci**	< 800
		P3.2 Acciai per utensili, per cuscinetti volventi, armonici e per lavorazioni veloci**	< 1.000
		P3.3 Acciai per utensili, per cuscinetti volventi, armonici e per lavorazioni veloci**	< 1.500
	P5	P5.1 Acciaio fuso	
M	M1	M1.1 Acciai inossidabili, austenitici	< 700
		M1.2 Acciai inossidabili, ferritici/austenitici (Duplex)	< 1.000
K	K1	K1.1 Ghisa con grafite lamellare (ghisa grigia), GJL	< 300
		K2.1 Ghisa con grafite sferoidale, GJS	< 500
	K2	K2.2 Ghisa con grafite sferoidale, GJS	≤ 800
		K2.3 Ghisa con grafite sferoidale, GJS	> 800
	K3	K3.1 Ghisa con grafite vermicolare, GJV; acciaio fuso malleabile, GJM	< 500
		K3.2 Ghisa con grafite vermicolare, GJV; acciaio fuso malleabile, GJM	> 500

MEGA-Speed-Drill-Steel | SCD621

GTM*		Materiale	Resistenza/durezza [N/mm ²] [HRC]
P	P1	P1.1 Acciai da costruzione, automatici, da cementazione e da bonifica, non legati	< 700
		P1.2 Acciai da costruzione, automatici, da cementazione e da bonifica, non legati	< 1.200
	P2	P2.1 Acciai da nitrazione, da cementazione e da bonifica, legati	< 900
		P2.2 Acciai da nitrazione, da cementazione e da bonifica, legati	< 1.400
	P3	P3.1 Acciai per utensili, per cuscinetti volventi, armonici e per lavorazioni veloci**	< 800
		P3.2 Acciai per utensili, per cuscinetti volventi, armonici e per lavorazioni veloci**	< 1.000
		P3.3 Acciai per utensili, per cuscinetti volventi, armonici e per lavorazioni veloci**	< 1.500
	P4	P4.1 Acciai inossidabili, ferritici e martensitici	
	P5	P5.1 Acciaio fuso	
	P6	P6.1 Acciaio fuso, ferritico e martensitico	
M	M1	M1.1 Acciai inossidabili, austenitici	< 700
		M1.2 Acciai inossidabili, ferritici/austenitici (Duplex)	< 1.000
	M2	M2.1 Acciaio fuso inossidabile, austenitico	< 700
	M3	M3.1 Acciaio fuso inossidabile, ferritico/austenitico (Duplex)	< 1.000
K	K1	K1.1 Ghisa con grafite lamellare (ghisa grigia), GJL	< 300
		K2.1 Ghisa con grafite sferoidale, GJS	< 500
	K2	K2.2 Ghisa con grafite sferoidale, GJS	≤ 800
		K2.3 Ghisa con grafite sferoidale, GJS	> 800
	K3	K3.1 Ghisa con grafite vermicolare, GJV; acciaio fuso malleabile, GJM	< 500
		K3.2 Ghisa con grafite vermicolare, GJV; acciaio fuso malleabile, GJM	> 500

* Gruppi di materiale MAPAL

** Qualora la somma dei componenti di lega Cr, Mo, Ni, V, W equivalesse a > 8%, selezionare il gruppo di materiale MAPAL immediatamente superiore.

	Velocità di taglio v_c [m/min]				Avanzamento f [mm] con diametro punta					
	Adduzione interna del refrigerante	Raffreddamento esterno	MQL	Aria	4,00	5,50	7,50	10,50	14,50	20,00
	115	105	105		0,24	0,30	0,37	0,46	0,56	0,65
	105	85	85		0,30	0,37	0,46	0,58	0,70	0,81
	115	100	100		0,28	0,35	0,44	0,55	0,66	0,77
	80	70	70		0,24	0,29	0,36	0,44	0,53	0,61
	85	75	75		0,25	0,31	0,39	0,49	0,60	0,69
	70	65	65		0,21	0,26	0,33	0,41	0,49	0,56
	70	50	60		0,18	0,21	0,26	0,32	0,38	0,43
	115	100	100		0,28	0,35	0,44	0,55	0,66	0,77
	55	35	35		0,11	0,14	0,18	0,22	0,27	0,31
	140	100	100	100	0,34	0,45	0,58	0,75	0,92	1,08
	185	115	140	140	0,34	0,43	0,55	0,70	0,85	1,00
	115	85	85		0,30	0,38	0,48	0,61	0,74	0,86
	70	45	60		0,16	0,20	0,25	0,31	0,38	0,44
	105	90	90		0,32	0,41	0,52	0,65	0,79	0,92
	90	80	80		0,27	0,34	0,42	0,52	0,63	0,73

	Velocità di taglio v_c [m/min]				Avanzamento f [mm] con diametro punta					
	Adduzione interna del refrigerante	Raffreddamento esterno	MQL	Aria	3,00	4,50	6,50	9,50	14,00	20,00
	170	155	155		0,13	0,17	0,22	0,29	0,36	0,43
	155	130	130		0,16	0,21	0,28	0,36	0,45	0,54
	170	145	145		0,15	0,20	0,26	0,34	0,43	0,51
	120	100	100		0,13	0,17	0,21	0,27	0,34	0,40
	130	110	110		0,13	0,18	0,23	0,30	0,39	0,46
	100	95	95		0,12	0,15	0,20	0,25	0,32	0,37
	100	75	85		0,10	0,12	0,16	0,20	0,25	0,29
	100	75	85		0,09	0,12	0,16	0,20	0,25	0,30
	170	145	145		0,15	0,20	0,26	0,34	0,43	0,51
	100	75	85		0,09	0,12	0,16	0,20	0,25	0,30
	65	40	40		0,07	0,09	0,12	0,15	0,19	0,23
	60	35	35		0,06	0,08	0,10	0,13	0,17	0,20
	65	40	40		0,07	0,09	0,12	0,15	0,19	0,23
	60	35	35		0,06	0,08	0,10	0,13	0,17	0,20
	150	105	105	105	0,14	0,21	0,28	0,38	0,49	0,59
	200	125	150	150	0,14	0,20	0,27	0,36	0,46	0,54
	125	95	95		0,13	0,18	0,24	0,31	0,39	0,47
	75	50	65		0,09	0,12	0,15	0,19	0,24	0,28
	115	100	100		0,14	0,19	0,25	0,33	0,42	0,50
	100	90	90		0,12	0,16	0,21	0,27	0,34	0,40

I parametri di lavorazione indicati sono valori orientativi.

I dati ottimali per la specifica applicazione devono essere rilevati eseguendo diversi tentativi o durante l'effettiva lavorazione.

Parametri di lavorazione consigliati per punte in metallo duro integrale

Avanzamento e velocità di taglio

MEGA-180°-Drill | SCD231

GTM*		Materiale	Resistenza/durezza [N/mm ²] [HRC]
P	P1	P1.1 Acciai da costruzione, automatici, da cementazione e da bonifica, non legati	< 700
		P1.2 Acciai da costruzione, automatici, da cementazione e da bonifica, non legati	< 1.200
	P2	P2.1 Acciai da nitrurazione, da cementazione e da bonifica, legati	< 900
		P2.2 Acciai da nitrurazione, da cementazione e da bonifica, legati	< 1.400
	P3	P3.1 Acciai per utensili, per cuscinetti volventi, armonici e per lavorazioni veloci**	< 800
		P3.2 Acciai per utensili, per cuscinetti volventi, armonici e per lavorazioni veloci**	< 1.000
		P3.3 Acciai per utensili, per cuscinetti volventi, armonici e per lavorazioni veloci**	< 1.500
	P5	P5.1 Acciaio fuso	
K	K1	K1.1 Ghisa con grafite lamellare (ghisa grigia), GJL	< 300
		K2.1 Ghisa con grafite sferoidale, GJS	< 500
	K2	K2.2 Ghisa con grafite sferoidale, GJS	≤ 800
		K2.3 Ghisa con grafite sferoidale, GJS	> 800
	K3	K3.1 Ghisa con grafite vermicolare, GJV; acciaio fuso malleabile, GJM	< 500
		K3.2 Ghisa con grafite vermicolare, GJV; acciaio fuso malleabile, GJM	> 500

ECU-Drill-Steel | SCD360, 361

GTM*		Materiale	Resistenza/durezza [N/mm ²] [HRC]
P	P1	P1.1 Acciai da costruzione, automatici, da cementazione e da bonifica, non legati	< 700
		P1.2 Acciai da costruzione, automatici, da cementazione e da bonifica, non legati	< 1.200
	P2	P2.1 Acciai da nitrurazione, da cementazione e da bonifica, legati	< 900
		P2.2 Acciai da nitrurazione, da cementazione e da bonifica, legati	< 1.400
	P3	P3.1 Acciai per utensili, per cuscinetti volventi, armonici e per lavorazioni veloci**	< 800
		P3.2 Acciai per utensili, per cuscinetti volventi, armonici e per lavorazioni veloci**	< 1.000
		P3.3 Acciai per utensili, per cuscinetti volventi, armonici e per lavorazioni veloci**	< 1.500
	P4	P4.1 Acciai inossidabili, ferritici e martensitici	
	P5	P5.1 Acciaio fuso	
	P6	P6.1 Acciaio fuso, ferritico e martensitico	
K	K1	K1.1 Ghisa con grafite lamellare (ghisa grigia), GJL	< 300
		K2.1 Ghisa con grafite sferoidale, GJS	< 500
	K2	K2.2 Ghisa con grafite sferoidale, GJS	≤ 800
		K2.3 Ghisa con grafite sferoidale, GJS	> 800
	K3	K3.1 Ghisa con grafite vermicolare, GJV; acciaio fuso malleabile, GJM	< 500
		K3.2 Ghisa con grafite vermicolare, GJV; acciaio fuso malleabile, GJM	> 500

* Gruppi di materiale MAPAL

** Qualora la somma dei componenti di lega Cr, Mo, Ni, V, W equivalesse a > 8%, selezionare il gruppo di materiale MAPAL immediatamente superiore.

	Velocità di taglio v_c [m/min]				Avanzamento f [mm] con diametro punta					
	Adduzione interna del refrigerante	Raffreddamento esterno	MQL	Aria	3,00	4,50	6,50	9,50	14,00	20,00
	80	70	70		0,07	0,09	0,12	0,16	0,20	0,24
	70	60	60		0,09	0,12	0,15	0,20	0,25	0,30
	80	70	70		0,08	0,11	0,14	0,19	0,24	0,28
	55	50	50		0,07	0,09	0,12	0,15	0,19	0,22
	60	50	50		0,07	0,10	0,13	0,17	0,21	0,25
	50	45	45		0,06	0,08	0,11	0,14	0,17	0,21
	50	35	40		0,05	0,07	0,09	0,11	0,14	0,16
	80	70	70		0,08	0,11	0,14	0,19	0,24	0,28
	95	70	70	70	0,09	0,14	0,19	0,25	0,33	0,39
	130	80	95	95	0,10	0,13	0,18	0,24	0,30	0,36
	80	60	60		0,09	0,12	0,16	0,21	0,26	0,31
	50	30	40		0,06	0,08	0,11	0,14	0,17	0,21
	70	65	65		0,09	0,13	0,17	0,22	0,28	0,33
	65	55	55		0,08	0,11	0,14	0,18	0,22	0,26

	Velocità di taglio v_c [m/min]				Avanzamento f [mm] con diametro punta					
	Adduzione interna del refrigerante	Raffreddamento esterno	MQL	Aria	1,00	1,82	3,31	6,03	10,99	20,00
	75	70	70		0,04	0,06	0,08	0,13	0,20	0,27
	70	55	55		0,05	0,07	0,11	0,16	0,24	0,33
	75	65	65		0,05	0,07	0,10	0,15	0,23	0,31
	55	45	45		0,05	0,06	0,09	0,13	0,18	0,25
	55	50	50		0,04	0,06	0,09	0,14	0,21	0,28
	45	40	40		0,04	0,05	0,08	0,12	0,17	0,23
	45	35	40		0,04	0,05	0,06	0,09	0,13	0,18
	45	35	40		0,03	0,04	0,06	0,09	0,14	0,19
	75	65	65		0,05	0,07	0,10	0,15	0,23	0,31
	45	35	40		0,03	0,04	0,06	0,09	0,14	0,19
	80	60	60	60	0,04	0,07	0,12	0,20	0,32	0,44
	110	70	80	80	0,05	0,07	0,12	0,19	0,30	0,41
	70	50	50		0,04	0,07	0,11	0,17	0,26	0,35
	40	25	35		0,04	0,05	0,08	0,12	0,17	0,23
	60	55	55		0,05	0,07	0,11	0,18	0,27	0,38
	55	50	50		0,05	0,07	0,10	0,15	0,22	0,30

I parametri di lavorazione indicati sono valori orientativi.

I dati ottimali per la specifica applicazione devono essere rilevati eseguendo diversi tentativi o durante l'effettiva lavorazione.

Parametri di lavorazione consigliati per punte in metallo duro integrale

Avanzamento e velocità di taglio

MEGA-Drill-Inox | SCD120, 121

GTM*		Materiale	Resistenza/durezza [N/mm ²] [HRC]
P	P1	P1.1 Acciai da costruzione, automatici, da cementazione e da bonifica, non legati	< 700
		P1.2 Acciai da costruzione, automatici, da cementazione e da bonifica, non legati	< 1.200
	P2	P2.1 Acciai da niturazione, da cementazione e da bonifica, legati	< 900
		P2.2 Acciai da niturazione, da cementazione e da bonifica, legati	< 1.400
	P3	P3.1 Acciai per utensili, per cuscinetti volventi, armonici e per lavorazioni veloci**	< 800
		P3.2 Acciai per utensili, per cuscinetti volventi, armonici e per lavorazioni veloci**	< 1.000
		P3.3 Acciai per utensili, per cuscinetti volventi, armonici e per lavorazioni veloci**	< 1.500
	P4	P4.1 Acciai inossidabili, ferritici e martensitici	
	P5	P5.1 Acciaio fuso	
	P6	P6.1 Acciaio fuso, ferritico e martensitico	
M	M1	M1.1 Acciai inossidabili, austenitici	< 700
		M1.2 Acciai inossidabili, ferritici/austenitici (Duplex)	< 1.000
	M2	M2.1 Acciaio fuso inossidabile, austenitico	< 700
		M3.1 Acciaio fuso inossidabile, ferritico/austenitico (Duplex)	< 1.000
K	K1	K1.1 Ghisa con grafite lamellare (ghisa grigia), GJL	< 300
		K2.1 Ghisa con grafite sferoidale, GJS	< 500
	K2	K2.2 Ghisa con grafite sferoidale, GJS	≤ 800
		K2.3 Ghisa con grafite sferoidale, GJS	> 800
	K3	K3.1 Ghisa con grafite vermicolare, GJV; acciaio fuso malleabile, GJM	< 500
		K3.2 Ghisa con grafite vermicolare, GJV; acciaio fuso malleabile, GJM	> 500
N	N2	N2.1 Rame, non legato e bassolegato	< 300
		N2.2 Rame, legato	> 300
	N2.3 Ottone, bronzo, ghisa rossa	< 1.200	

MEGA-Speed-Drill-Inox | SCD411

GTM*		Materiale	Resistenza/durezza [N/mm ²] [HRC]
P	P1	P1.1 Acciai da costruzione, automatici, da cementazione e da bonifica, non legati	< 700
		P1.2 Acciai da costruzione, automatici, da cementazione e da bonifica, non legati	< 1.200
	P2	P2.1 Acciai da niturazione, da cementazione e da bonifica, legati	< 900
		P2.2 Acciai da niturazione, da cementazione e da bonifica, legati	< 1.400
	P3	P3.1 Acciai per utensili, per cuscinetti volventi, armonici e per lavorazioni veloci**	< 800
		P3.2 Acciai per utensili, per cuscinetti volventi, armonici e per lavorazioni veloci**	< 1.000
		P3.3 Acciai per utensili, per cuscinetti volventi, armonici e per lavorazioni veloci**	< 1.500
	P4	P4.1 Acciai inossidabili, ferritici e martensitici	
	P5	P5.1 Acciaio fuso	
	P6	P6.1 Acciaio fuso, ferritico e martensitico	
M	M1	M1.1 Acciai inossidabili, austenitici	< 700
		M1.2 Acciai inossidabili, ferritici/austenitici (Duplex)	< 1.000
	M2	M2.1 Acciaio fuso inossidabile, austenitico	< 700
		M3.1 Acciaio fuso inossidabile, ferritico/austenitico (Duplex)	< 1.000
S	S1	S1.1 Titanio, leghe di titanio	< 400
		S2.1 Titanio, leghe di titanio	< 1.200
		S2.2 Titanio, leghe di titanio	> 1.200
	S3	S3.1 Nichel, non legato e legato	< 900
		S3.2 Nichel, non legato e legato	> 900
	S4	S4.1 Superlega resistente ad alte temperature a base di Ni, Co e Fe	
	S5	S5.1 Leghe di tungsteno e molibdeno	

* Gruppi di materiale MAPAL

** Qualora la somma dei componenti di lega Cr, Mo, Ni, V, W equivalesse a > 8%, selezionare il gruppo di materiale MAPAL immediatamente superiore.

	Velocità di taglio v_c [m/min]				Avanzamento f [mm] con diametro punta					
	Adduzione interna del refrigerante	Raffreddamento esterno	MQL	Aria	3,00	4,50	6,50	9,50	14,00	20,00
	100	90	90		0,07	0,09	0,12	0,16	0,20	0,24
	90	75	75		0,09	0,12	0,15	0,20	0,25	0,30
	100	85	85		0,08	0,11	0,14	0,19	0,24	0,28
	70	60	60		0,07	0,09	0,12	0,15	0,19	0,22
	75	65	65		0,07	0,10	0,13	0,17	0,21	0,25
	60	55	55		0,06	0,08	0,11	0,14	0,17	0,21
	60	45	50		0,05	0,07	0,09	0,11	0,14	0,16
	60	45	50		0,05	0,07	0,09	0,11	0,14	0,17
	100	85	85		0,08	0,11	0,14	0,19	0,24	0,28
	60	45	50		0,05	0,07	0,09	0,11	0,14	0,17
	55	35	35		0,06	0,08	0,11	0,14	0,18	0,21
	50	30	30		0,05	0,07	0,09	0,12	0,15	0,18
	55	35	35		0,06	0,08	0,11	0,14	0,18	0,21
	50	30	30		0,05	0,07	0,09	0,12	0,15	0,18
	120	85	85	85	0,12	0,17	0,24	0,32	0,41	0,49
	160	100	120	120	0,12	0,17	0,22	0,30	0,38	0,45
	100	75	75		0,11	0,15	0,20	0,26	0,33	0,39
	60	40	50		0,08	0,10	0,13	0,17	0,22	0,26
	90	80	80		0,12	0,16	0,21	0,28	0,35	0,42
	80	70	70		0,10	0,13	0,17	0,22	0,28	0,33
	140	100			0,09	0,12	0,15	0,20	0,25	0,30
	120	90			0,11	0,15	0,20	0,26	0,33	0,39
	200	160	160	120	0,12	0,17	0,24	0,32	0,41	0,49

	Velocità di taglio v_c [m/min]				Avanzamento f [mm] con diametro punta					
	Adduzione interna del refrigerante	Raffreddamento esterno	MQL	Aria	3,00	4,50	6,50	9,50	14,00	20,00
	150	135	135		0,09	0,12	0,15	0,20	0,25	0,30
	135	115	115		0,11	0,15	0,19	0,25	0,31	0,37
	150	130	130		0,10	0,14	0,18	0,23	0,30	0,35
	105	90	90		0,09	0,12	0,15	0,19	0,24	0,28
	115	100	100		0,09	0,12	0,16	0,21	0,27	0,32
	90	85	85		0,08	0,10	0,13	0,17	0,22	0,26
	90	70	75		0,07	0,09	0,11	0,14	0,17	0,20
	70	55	60		0,06	0,08	0,11	0,14	0,18	0,21
	150	130	130		0,10	0,14	0,18	0,23	0,30	0,35
	70	55	60		0,06	0,08	0,11	0,14	0,18	0,21
	80	50	50		0,08	0,10	0,13	0,17	0,22	0,26
	75	45	45		0,07	0,09	0,11	0,15	0,19	0,22
	80	50	50		0,08	0,10	0,13	0,17	0,22	0,26
	75	45	45		0,07	0,09	0,11	0,15	0,19	0,22
					0,07	0,10	0,13	0,17	0,21	0,25
	35	25			0,06	0,08	0,11	0,14	0,18	0,21
	30	20			0,05	0,07	0,09	0,12	0,15	0,18
	25	20			0,04	0,06	0,07	0,10	0,12	0,14
	20	10			0,05	0,07	0,09	0,12	0,15	0,18
	20	10			0,04	0,06	0,07	0,10	0,12	0,14
	20	10			0,04	0,06	0,07	0,10	0,12	0,14

I parametri di lavorazione indicati sono valori orientativi.

I dati ottimali per la specifica applicazione devono essere rilevati eseguendo diversi tentativi o durante l'effettiva lavorazione.

Parametri di lavorazione consigliati per punte in metallo duro integrale

Avanzamento e velocità di taglio

MEGA-Speed-Drill-Iron | SCD421

GTM*	Materiale		Resistenza/durezza [N/mm ²] [HRC]
K	K1	K1.1 Ghisa con grafite lamellare (ghisa grigia), GJL	< 300
		K2.1 Ghisa con grafite sferoidale, GJS	< 500
	K2	K2.2 Ghisa con grafite sferoidale, GJS	≤ 800
		K2.3 Ghisa con grafite sferoidale, GJS	> 800
	K3	K3.1 Ghisa con grafite vermicolare, GJV; acciaio fuso malleabile, GJM	< 500
		K3.2 Ghisa con grafite vermicolare, GJV; acciaio fuso malleabile, GJM	> 500

MEGA-Drill-Alu | SCD131

GTM*	Materiale		Resistenza/durezza [N/mm ²] [HRC]
N	N1	N1.1 Alluminio, non legato e legato < 3% Si	
		N1.2 Alluminio, legato ≤ 7% Si	
		N1.3 Alluminio, legato > 7-12% Si	
		N1.4 Alluminio, legato > 12% Si	
	N2	N2.1 Rame, non legato e bassolegato	< 300
		N2.2 Rame, legato	> 300
N2.3 Ottone, bronzo, ghisa rossa		< 1.200	

MEGA-Drill-Composite-MD | SCD250

GTM*	Materiale		Resistenza/durezza [N/mm ²] [HRC]	
N	N3	N3.1 Grafite, > 8 μm		
		N3.2 Grafite, ≤ 8 μm		
C	C1	C1.1 Matrice plastica, rinforzata con fibre di aramide (AFK)		
		C1.2 Matrice plastica (duroplastica), CFK/GFK		
		C1.3 Matrice plastica (termoplastica), CFK/GFK		
	C2	C2.1 Matrice in carbonio, rinforzata con fibre di carbonio (CFC)		
		C3	C3.1 Matrice metallica (MMC)	
			C4.1 Struttura a sandwich, nucleo a nido d'ape (Honeycomb)	
C4	C4.2 Struttura a sandwich, nucleo in materiale espanso			

MEGA-Drill-Composite-UDX | SCD270, 271

GTM*	Materiale		Resistenza/durezza [N/mm ²] [HRC]
C	C1	C1.1 Matrice plastica, rinforzata con fibre di aramide (AFK)	
		C1.2 Matrice plastica (duroplastica), CFK/GFK	
		C1.3 Matrice plastica (termoplastica), CFK/GFK	
	C2	C2.1 Matrice in carbonio, rinforzata con fibre di carbonio (CFC)	

* Gruppi di materiale MAPAL

	Velocità di taglio v_c [m/min]				Avanzamento f [mm] con diametro punta					
	Adduzione interna del refrigerante	Raffreddamento esterno	MQL	Aria	3,00	4,50	6,50	9,50	14,00	20,00
	170	120	120	120	0,15	0,21	0,29	0,40	0,51	0,61
	225	140	170	170	0,15	0,21	0,28	0,37	0,48	0,57
	140	105	105		0,14	0,19	0,25	0,32	0,41	0,49
	85	55	70		0,10	0,13	0,17	0,22	0,27	0,32
	125	110	110		0,15	0,20	0,26	0,35	0,44	0,52
	110	100	100		0,13	0,17	0,22	0,28	0,35	0,41

	Velocità di taglio v_c [m/min]				Avanzamento f [mm] con diametro punta					
	Adduzione interna del refrigerante	Raffreddamento esterno	MQL	Aria	3,00	4,50	6,50	9,50	14,00	20,00
	300	200	250		0,09	0,12	0,15	0,20	0,25	0,30
	250	180	200		0,11	0,15	0,20	0,26	0,33	0,39
	220	150	180		0,11	0,15	0,20	0,26	0,33	0,39
	180	120	150		0,11	0,15	0,20	0,26	0,33	0,39
	140	100			0,09	0,12	0,15	0,20	0,25	0,30
	120	90			0,11	0,15	0,20	0,26	0,33	0,39
	200	160	160	120	0,09	0,14	0,19	0,25	0,33	0,39

	Velocità di taglio v_c [m/min]				Avanzamento f [mm] con diametro punta					
	Adduzione interna del refrigerante	Raffreddamento esterno	MQL	Aria	3,00	4,00	5,50	7,50	10,00	12,00
				200	0,07	0,09	0,11	0,14	0,16	0,18
				200	0,07	0,09	0,11	0,14	0,16	0,18
				90	0,04	0,04	0,05	0,06	0,07	0,08
				75	0,04	0,04	0,05	0,06	0,07	0,08
				75	0,04	0,04	0,05	0,06	0,07	0,08
				400	0,04	0,04	0,05	0,06	0,07	0,08
				400	0,04	0,04	0,05	0,06	0,07	0,08

	Velocità di taglio v_c [m/min]				Avanzamento f [mm] con diametro punta					
	Adduzione interna del refrigerante	Raffreddamento esterno	MQL	Aria	3,00	4,00	5,50	7,50	10,00	12,00
				90	0,04	0,04	0,05	0,06	0,07	0,08
				75	0,04	0,04	0,05	0,06	0,07	0,08
				75	0,04	0,04	0,05	0,06	0,07	0,08

I parametri di lavorazione indicati sono valori orientativi.

I dati ottimali per la specifica applicazione devono essere rilevati eseguendo diversi tentativi o durante l'effettiva lavorazione.

Parametri di lavorazione consigliati per punte in metallo duro integrale

Avanzamento e velocità di taglio

MEGA-180°-Drill-Alu | SCD241

GTM*		Materiale	Resistenza/durezza [N/mm ²] [HRC]
N	N1	N1.1 Alluminio, non legato e legato < 3% Si	
		N1.2 Alluminio, legato ≤ 7% Si	
		N1.3 Alluminio, legato > 7-12% Si	
		N1.4 Alluminio, legato > 12% Si	
	N2	N2.1 Rame, non legato e bassolegato	< 300
		N2.2 Rame, legato	> 300
		N2.3 Ottone, bronzo, ghisa rossa	< 1.200

ECU-G-Drill | SCD211

GTM*		Materiale	Resistenza/durezza [N/mm ²] [HRC]
K	K1	K1.1 Ghisa con grafite lamellare (ghisa grigia), GJL	< 300
		K2.1 Ghisa con grafite sferoidale, GJS	< 500
	K2	K2.2 Ghisa con grafite sferoidale, GJS	≤ 800
		K2.3 Ghisa con grafite sferoidale, GJS	> 800
N	N1	N1.1 Alluminio, non legato e legato < 3% Si	
		N1.2 Alluminio, legato ≤ 7% Si	
		N1.3 Alluminio, legato > 7-12% Si	
		N1.4 Alluminio, legato > 12% Si	
	N2	N2.1 Rame, non legato e bassolegato	< 300
		N2.2 Rame, legato	> 300
		N2.3 Ottone, bronzo, ghisa rossa	< 1.200

* Gruppi di materiale MAPAL

	Velocità di taglio v_c [m/min]				Avanzamento f [mm] con diametro punta					
	Adduzione interna del refrigerante	Raffreddamento esterno	MQL	Aria	3,00	4,50	6,50	9,50	14,00	20,00
	240	160	200		0,07	0,09	0,12	0,16	0,20	0,24
	200	145	160		0,09	0,12	0,16	0,21	0,26	0,31
	175	120	145		0,09	0,12	0,16	0,21	0,26	0,31
	145	95	120		0,09	0,12	0,16	0,21	0,26	0,31
	110	80			0,07	0,09	0,12	0,16	0,20	0,24
	95	70			0,09	0,12	0,16	0,21	0,26	0,31
	160	130	130	95	0,09	0,14	0,19	0,25	0,33	0,39

	Velocità di taglio v_c [m/min]				Avanzamento f [mm] con diametro punta					
	Adduzione interna del refrigerante	Raffreddamento esterno	MQL	Aria	3,00	4,50	6,50	9,50	14,00	20,00
	90	65	65	65	0,08	0,12	0,16	0,22	0,29	0,34
	120	75	90	90	0,08	0,12	0,16	0,21	0,27	0,32
	75	55	55		0,08	0,10	0,14	0,18	0,23	0,27
	215	155	170		0,08	0,10	0,14	0,18	0,23	0,27
	185	130	155		0,08	0,10	0,14	0,18	0,23	0,27
	155	100	130		0,08	0,10	0,14	0,18	0,23	0,27
	160	130	130	95	0,08	0,12	0,16	0,22	0,29	0,34

I parametri di lavorazione indicati sono valori orientativi.

I dati ottimali per la specifica applicazione devono essere rilevati eseguendo diversi tentativi o durante l'effettiva lavorazione.



UTENSILI DI FORATURA A FISSAGGIO MECCANICO

Punta con inserto QTD

Tecnologia	184
Tipo 01 - Steel	186
Tipo 05 - Steel-Pyramid	188
Tipo 10 - Uni, forma EK	190
Tipo 02 - Inox	191
Tipo 04 - Iron	193
Tipo 03 - Alu	194
Supporto per inserto QTS	195
Accessori e parti di ricambio	199
Parametri di lavorazione consigliati.....	200

Punta ad inserto intercambiabile TTD

Tecnologia	204
Tipo 01 - Uni-Plus	206
Tipo 04 - Steel	207
Tipo 02 - Inox	209
Tipo 05 - Iron	211
Tipo 03 - Alu	212
Supporto per testina intercambiabile TTS	213
Accessori e parti di ricambio	222
Parametri di lavorazione consigliati.....	224

Punta ad inserto intercambiabile TTD-Tritan

Tecnologia	228
Tipo 01 - Uni	230
Supporto per testina intercambiabile TTS-300	231
Accessori e parti di ricambio	234
Parametri di lavorazione consigliati	236





PUNTA CON INSERTO QTD

Sede dei taglienti stabile, sistema di serraggio semplice

Con modernissima tecnologia di produzione nel range di diametro da 8 a 50 mm

La punta con inserti QTD per il range di diametro da medio ad alto è caratterizzata da un'ottima formazione e da un'asportazione sicura dei trucioli. Sono possibili numerosi cambi inserto per supporto, poiché il supporto di base non si consuma. Particolarmente semplice, ma nel contempo molto efficace, è anche la costruzione del sistema di serraggio per l'inserto. È composto da una vite che, avvitata attraverso l'inserto in senso trasversale, lo mantiene saldamente nella sede a prisma. L'inserto a fissaggio meccanico viene mantenuto nella sede a prisma in modo particolarmente stabile, consentendo elevati dati di taglio e ottime qualità del foro.

La stampa additiva consente di realizzare il canale di raffreddamento in modo ottimale e di ottenere diametri a partire da 9 mm

Al fine di realizzare anche diametri inferiori ai 13 mm viene impiegata la stampa additiva. Questa procedura consente di produrre corpi base in un range di diametro dagli 8 ai 13 mm, con canali di raffreddamento elicoidali. Rispetto all'adduzione centrale del refrigerante con deviazioni, questa versione con canali di raffreddamento elicoidali consente di ottenere un flusso di refrigerante maggiorato del 100%, in particolare grazie a profili dei canali di raffreddamento diversi dalla consueta forma circolare.

Caratteristiche utensile nel dettaglio



1 Codolo secondo ISO 9766

2 Superficie di appoggio codolo piana

3 Curva caratteristica per profondità di foratura massima

4 Scoprimento del dorso

- Per un'asportazione dei trucioli ottimale

5 Trasmissione di forza ottimale

- Grazie all'inserto integrato

6 Sede in acciaio temprato con codolo cilindrico

7 Stabile serraggio TORX PLUS®

8 Sede inserto prismatica

- Per un centraggio ottimale dell'inserto

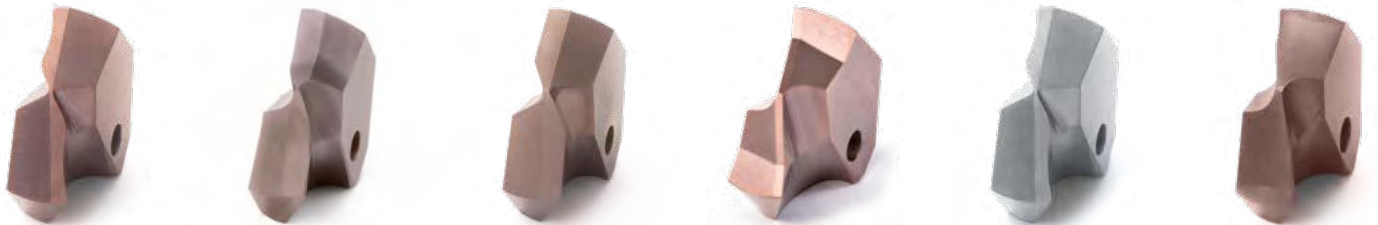

IN SINTESI

- Pronta consegna
- Range di diametro da 9 a 50 mm
- Assortimento supporti 1,5 | 3 | 5 | 8 e 12xD
- Inserti per acciaio, acciaio inossidabile, alluminio e ghisa
- Con adduzione interna del refrigerante
- Speciale trattamento della superficie
- Semplicità di utilizzo, cambio inserto nella macchina

CARATTERISTICHE E PRESTAZIONI

- Stesse prestazioni di una punta in metallo duro integrale
- Elevata precisione di concentricità
- Spallamento stabile per assorbire forze assiali elevate
- Serraggio sicuro dell'inserto con vite TORX PLUS®
- Sistema robusto

VANTAGGI

- Costi ottimizzati
- Massime prestazioni
- Montaggio dell'inserto con sistema anti-sfilamento
- Ottima formazione dei trucioli nell'inserto e asportazione dei trucioli
- Un supporto per tutte le geometrie di punta
- Possibilità di numerosi cambi inserto, poiché il supporto di base non si consuma

Inserti QTD

In metallo duro integrale, adduzione interna del refrigerante
 Tipo 01 - Steel

Versione:

Diametro punta: 9,00 - 50,00 mm

 Tolleranza di foratura: \geq IT 10

Materiale da taglio: HP240

Numero di taglienti: 2

Numero margini di guida: 2

Angolo tra taglienti: 135°

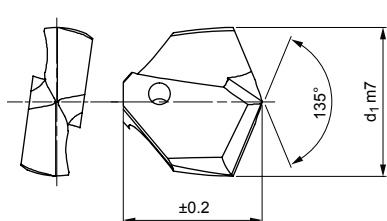
Serie selezionata per il magazzino

d ₁ da 9,00 a 15,50			
d ₁ m7	Dimensioni supporto D	Specifiche	Codice
9,00	9	QTD-2F01-0900-HP240	30615635
9,50	9,5	QTD-2F01-0950-HP240	30615636
10,00	10	QTD-2F01-1000-HP240	30615638
10,20	10	QTD-2F01-1020-HP240	30646024
10,50	10,5	QTD-2F01-1050-HP240	30615639
10,70	10,5	QTD-2F01-1070-HP240	30615640
11,00	11	QTD-2F01-1100-HP240	30615641
11,50	11,5	QTD-2F01-1150-HP240	30615642
12,00	12	QTD-2F01-1200-HP240	30615644
12,50	12,5	QTD-2F01-1250-HP240	30615645
12,70	12,5	QTD-2F01-1270-HP240	30615646
12,80	12,5	QTD-2F01-1280-HP240	30646043
13,00	13	QTD-2F01-1300-HP240	30572990
13,10	13	QTD-2F01-1310-HP240	30646045
13,30	13	QTD-2F01-1330-HP240	30646047
13,40	13	QTD-2F01-1340-HP240	30646048
13,50	13,5	QTD-2F01-1350-HP240	30572991
13,80	13,5	QTD-2F01-1380-HP240	30646050
13,90	13,5	QTD-2F01-1390-HP240	30646051
14,00	14	QTD-2F01-1400-HP240	30572993
14,10	14	QTD-2F01-1410-HP240	30646052
14,20	14	QTD-2F01-1420-HP240	30646053
14,30	14	QTD-2F01-1430-HP240	30646055
14,50	14,5	QTD-2F01-1450-HP240	30572994
14,60	14,5	QTD-2F01-1460-HP240	30646057
14,70	14,5	QTD-2F01-1470-HP240	30572995
14,80	14,5	QTD-2F01-1480-HP240	30646058
14,90	14,5	QTD-2F01-1490-HP240	30646059
15,00	15	QTD-2F01-1500-HP240	30572997
15,10	15	QTD-2F01-1510-HP240	30646060
15,20	15	QTD-2F01-1520-HP240	30646061
15,25	15	QTD-2F01-1525-HP240	30572998
15,50	15	QTD-2F01-1550-HP240	30572999

d ₁ da 15,70 a 19,50			
d ₁ m7	Dimensioni supporto D	Specifiche	Codice
15,70	15	QTD-2F01-1570-HP240	30573000
15,80	15	QTD-2F01-1580-HP240	30646066
15,90	15	QTD-2F01-1590-HP240	30646068
16,00	16	QTD-2F01-1600-HP240	30573001
16,10	16	QTD-2F01-1610-HP240	30573003
16,20	16	QTD-2F01-1620-HP240	30646069
16,25	16	QTD-2F01-1625-HP240	30573004
16,30	16	QTD-2F01-1630-HP240	30610882
16,40	16	QTD-2F01-1640-HP240	30646071
16,50	16	QTD-2F01-1650-HP240	30573005
16,60	16	QTD-2F01-1660-HP240	30646072
16,70	16	QTD-2F01-1670-HP240	30573006
16,80	16	QTD-2F01-1680-HP240	30646074
16,90	16	QTD-2F01-1690-HP240	30646075
17,00	17	QTD-2F01-1700-HP240	30573009
17,10	17	QTD-2F01-1710-HP240	30646076
17,20	17	QTD-2F01-1720-HP240	30646077
17,30	17	QTD-2F01-1730-HP240	30646078
17,40	17	QTD-2F01-1740-HP240	30646079
17,50	17	QTD-2F01-1750-HP240	30573010
17,60	17	QTD-2F01-1760-HP240	30646081
17,70	17	QTD-2F01-1770-HP240	30573011
17,80	17	QTD-2F01-1780-HP240	30646082
17,90	17	QTD-2F01-1790-HP240	30646083
18,00	18	QTD-2F01-1800-HP240	30573012
18,10	18	QTD-2F01-1810-HP240	30646084
18,50	18	QTD-2F01-1850-HP240	30573014
18,60	18	QTD-2F01-1860-HP240	30646088
18,70	18	QTD-2F01-1870-HP240	30573015
18,80	18	QTD-2F01-1880-HP240	30646089
18,90	18	QTD-2F01-1890-HP240	30646090
19,00	19	QTD-2F01-1900-HP240	30573016
19,50	19	QTD-2F01-1905-HP240	30646091

Inseri QTD in metallo duro integrale, adduzione interna del refrigerante - tipo 01

d ₁ da 19,10 a 24,70				d ₁ da 24,75 a 42,60			
d ₁ m7	Dimensioni supporto D	Specifiche	Codice	d ₁ m7	Dimensioni supporto D	Specifiche	Codice
19,10	19	QTD-2F01-1910-HP240	30646092	24,75	24	QTD-2F01-2475-HP240	30573046
19,20	19	QTD-2F01-1920-HP240	30573017	24,80	24	QTD-2F01-2480-HP240	30660662
19,25	19	QTD-2F01-1925-HP240	30573018	25,00	25	QTD-2F01-2500-HP240	30573047
19,30	19	QTD-2F01-1930-HP240	30646094	25,40	25	QTD-2F01-2540-HP240	30573048
19,50	19	QTD-2F01-1950-HP240	30573020	25,50	25	QTD-2F01-2550-HP240	30573049
19,60	19	QTD-2F01-1960-HP240	30646095	25,70	25	QTD-2F01-2570-HP240	30573050
19,70	19	QTD-2F01-1970-HP240	30573021	25,80	25	QTD-2F01-2580-HP240	30584730
19,75	19	QTD-2F01-1975-HP240	30573022	26,00	26	QTD-2F01-2600-HP240	30573051
19,80	19	QTD-2F01-1980-HP240	30646096	26,50	26	QTD-2F01-2650-HP240	30573052
19,90	19	QTD-2F01-1990-HP240	30646097	27,00	27	QTD-2F01-2700-HP240	30573053
20,00	20	QTD-2F01-2000-HP240	30573023	27,50	27	QTD-2F01-2750-HP240	30573054
20,40	20	QTD-2F01-2040-HP240	30573024	27,75	27	QTD-2F01-2775-HP240	30573055
20,50	20	QTD-2F01-2050-HP240	30573025	28,00	28	QTD-2F01-2800-HP240	30573056
20,70	20	QTD-2F01-2070-HP240	30573026	28,50	28	QTD-2F01-2850-HP240	30573058
20,75	20	QTD-2F01-2075-HP240	30573027	29,00	29	QTD-2F01-2900-HP240	30573059
21,00	21	QTD-2F01-2100-HP240	30573028	29,50	29	QTD-2F01-2950-HP240	30573060
21,50	21	QTD-2F01-2150-HP240	30573029	29,80	29	QTD-2F01-2980-HP240	30728319
21,70	21	QTD-2F01-2170-HP240	30573030	30,00	30	QTD-2F01-3000-HP240	30573062
22,00	22	QTD-2F01-2200-HP240	30573031	30,25	30	QTD-2F01-3025-HP240	30573063
22,25	22	QTD-2F01-2225-HP240	30573032	30,50	30	QTD-2F01-3050-HP240	30573064
22,50	22	QTD-2F01-2250-HP240	30573034	31,00	31	QTD-2F01-3100-HP240	30573066
22,70	22	QTD-2F01-2270-HP240	30573035	31,50	31	QTD-2F01-3150-HP240	30573067
22,75	22	QTD-2F01-2275-HP240	30573036	32,00	32	QTD-2F01-3200-HP240	30573068
23,00	23	QTD-2F01-2300-HP240	30573037	33,00	33	QTD-2F01-3300-HP240	30649656
23,25	23	QTD-2F01-2325-HP240	30573038	34,00	34	QTD-2F01-3400-HP240	30649657
23,50	23	QTD-2F01-2350-HP240	30573039	35,00	35	QTD-2F01-3500-HP240	30649658
23,75	23	QTD-2F01-2375-HP240	30573042	36,00	36	QTD-2F01-3600-HP240	30649659
24,00	24	QTD-2F01-2400-HP240	30573043	37,00	37	QTD-2F01-3700-HP240	30649660
24,30	24	QTD-2F01-2430-HP240	30646105	38,00	37	QTD-2F01-3800-HP240	30649661
24,50	24	QTD-2F01-2450-HP240	30573044	40,00	39	QTD-2F01-4000-HP240	30657233
24,70	24	QTD-2F01-2470-HP240	30573045	42,00	41	QTD-2F01-4200-HP240	30657235

Caratteristiche configurabili



Diametro:
Diametro a libera scelta a passi da 0,01 mm



Specifiche:
QTD-2F01-[diametro]-HP240

Esempio:
QTD-2F01-0901-HP240

Diametro utensile d₁ = 9,01 mm

Dimensioni serie configurabile

d ₁ min.	d ₁ max.
9,00	50,00

Misure in mm.

Per i parametri di lavorazione consigliati, vedere la fine del capitolo.

Versioni speciali e altri rivestimenti disponibili su richiesta.

Inserti QTD

In metallo duro integrale, adduzione interna del refrigerante
Tipo 05 - Steel-Pyramid

Versione:

Diametro punta: 14,00 - 32,00 mm
Tolleranza di foratura: \geq IT 10
Materiale da taglio: HP605
Numero di taglienti: 2
Numero margini di guida: 2
Angolo tra taglienti: 165°

Applicazione

Specifico per la lavorazione con particolari requisiti di centraggio dell'utensile (ad es. componenti con pareti sottili e condizioni di lavorazione instabili).

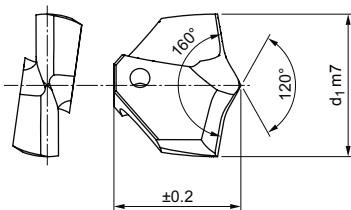

Serie selezionata per il magazzino

Dimensioni		Specifiche	Codice
d ₁ m7	Dimensioni supporto D		
14,00	14	QTD-2F05-1400-HP605	31126352
15,00	15	QTD-2F05-1500-HP605	31126356
16,00	16	QTD-2F05-1600-HP605	31126361
16,50	16	QTD-2F05-1650-HP605	31126364
17,50	17	QTD-2F05-1750-HP605	31126366
18,00	18	QTD-2F05-1800-HP605	31126368
18,50	18	QTD-2F05-1850-HP605	31126369
19,27	19	QTD-2F05-1927-HP605	31208007
19,80	19	QTD-2F05-1980-HP605	31126372
20,00	20	QTD-2F05-2000-HP605	31126373
20,50	20	QTD-2F05-2050-HP605	31126374
21,00	21	QTD-2F05-2100-HP605	31126375
21,50	21	QTD-2F05-2150-HP605	31126376
22,00	22	QTD-2F05-2200-HP605	31126377
23,00	23	QTD-2F05-2300-HP605	31126379
24,00	24	QTD-2F05-2400-HP605	31126380
25,00	25	QTD-2F05-2500-HP605	31126382
26,00	26	QTD-2F05-2600-HP605	31126384
26,50	26	QTD-2F05-2650-HP605	31126385
27,00	27	QTD-2F05-2700-HP605	31126386
28,00	28	QTD-2F05-2800-HP605	31126387
29,00	29	QTD-2F05-2900-HP605	31126388
30,00	30	QTD-2F05-3000-HP605	31126389
32,00	32	QTD-2F05-3200-HP605	31126391

Caratteristiche configurabili



Diametro:
Diametro a libera scelta a passi da 0,01 mm



Specifiche:

QTD-2F01-[diametro]-HP240

Dimensioni serie configurabile

d ₁ min.	d ₁ max.
14,00	32,00

Esempio:

QTD-2F01-1401-HP240

Diametro utensile d₁ = 14,01 mm

Misure in mm.

Per i parametri di lavorazione consigliati, vedere la fine del capitolo.
Versioni speciali e altri rivestimenti disponibili su richiesta.

Test di applicazione pratica

Lavorazione di lamiere, scambiatori di calore/ lamiere per caldaie, travi in acciaio (T, U, ...).

Specifico per la lavorazione con particolari requisiti di centraggio dell'utensile, componenti con pareti sottili e condizioni di lavorazione instabili.



Dati di lavorazione

Utensile:	∅ 18 mm 5xD
Mandrino di serraggio:	Mandrino di serraggio a superficie
Raffreddamento:	Adduzione interna del refrigerante con lubrificazione minimale
IB [mm]:	90
vc [m/min]:	63
n [min ⁻¹]:	1,115
f [mm]:	0,3
vf [mm/min]:	334

Numero fori

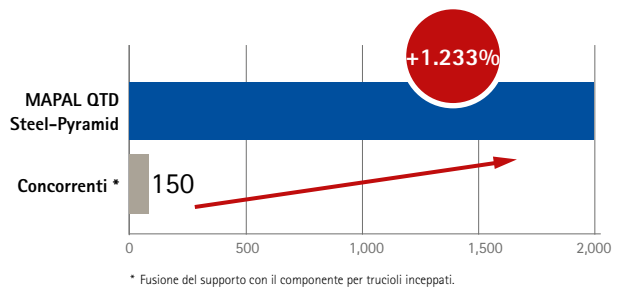

Inserti QTD

In metallo duro integrale,
Tipo 10 - Uni, forma EK

Versione:

Diametro punta: 10,00 - 33,00 mm
Tolleranza di foratura: \geq IT 10
Materiale da taglio: HP240
Numero di taglienti: 2
Numero margini di guida: 2
Angolo tra taglienti: 142°
Particolarità: Forma EK
Tagliente 180°,
smusso di protezione
0,5 mm

Applicazione

Per fori passanti per viti DIN-ISO 273 e svasature secondo DIN 74, foglio 2 forma H, J e K, versione centrale.

Per viti DIN 912, 6912 e 7984, ISO 1207 (DIN 84).

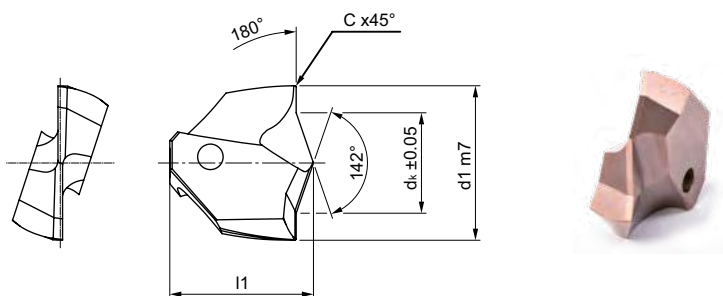

Serie selezionata per il magazzino

Dimensioni			Per viti a testa cilindrica DIN	Adatto per Ø Foro passante	Specifiche	Codice
d ₁ m7	d _k ±0,05	Dimensioni supporto D				
10,00	6,50	10	M5	5,5	QTD-2F10-1000-HP240	30868435
11,00	7,60	11	M6	6,6	QTD-2F10-1100-HP240	30868436
15,00	10,00	15	M8	9	QTD-2F10-1500-HP240	30868437
18,00	11,00	18	M10	11	QTD-2F10-1800-HP240	30868438
20,00	14,50	20	M12	13,5	QTD-2F10-2000-HP240	30868439
24,00	16,50	24	M14	15	QTD-2F10-2400-HP240	30868440
26,00	18,50	26	M16	17	QTD-2F10-2600-HP240	30868441
30,00	20,50	30	M18	19	QTD-2F10-3000-HP240	30868442
33,00	23,00	33	M20	21	QTD-2F10-3300-HP240	30868443

Indicazioni per l'utilizzo:

Realizzazione di un foro passante con svasatura piatta per viti a testa cilindrica secondo DIN (esempio M12)

1. Fase:

Svasatura con QTD tipo 10, forma EK (esempio diametro 20 mm)

2. Fase:

Foratura con punta in metallo duro integrale (esempio diametro 13,5 mm)

Risultato:

Foro passante con svasatura piatta e smusso per vite a testa cilindrica M12

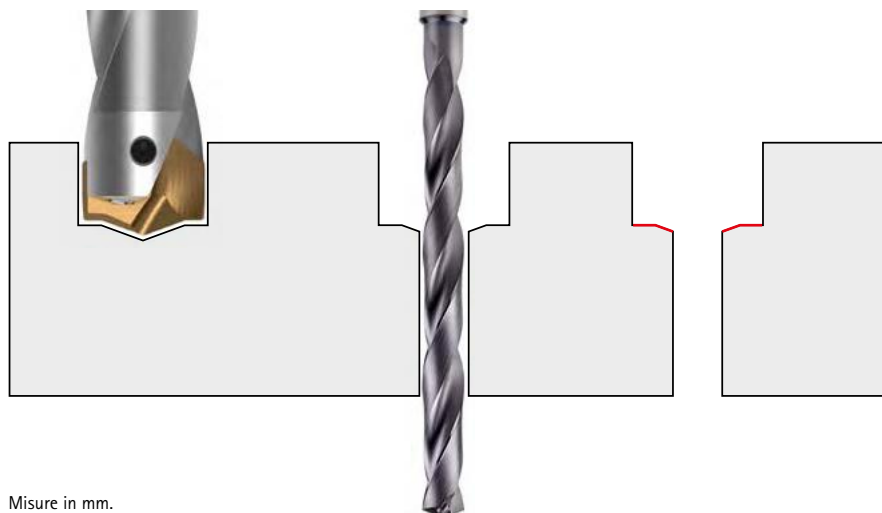

Misure in mm.

Per i parametri di lavorazione consigliati, vedere la fine del capitolo.

Versioni speciali e altri rivestimenti disponibili su richiesta.

Inserti QTD

In metallo duro integrale, adduzione interna del refrigerante
Tipo 02 - Inox

Versione:

Diametro punta: 9,00 - 50,00 mm
Tolleranza di foratura: \geq IT 10
Materiale da taglio: HP600
Numero di taglienti: 2
Numero margini di guida: 2
Angolo tra taglienti: 135°

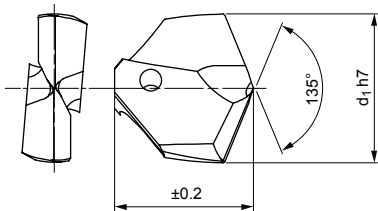

Serie selezionata per il magazzino

d ₁ da 10,00 a 16,70			
d ₁ h7	Dimensioni supporto D	Specifiche	Codice
10,00	10	QTD-2F02-1000-HP600	30615624
10,50	10,5	QTD-2F02-1050-HP600	30615625
11,00	11	QTD-2F02-1100-HP600	30615627
12,00	12	QTD-2F02-1200-HP600	30615630
12,50	12,5	QTD-2F02-1250-HP600	30615631
13,00	13	QTD-2F02-1300-HP600	30573070
13,50	13,5	QTD-2F02-1350-HP600	30573072
14,00	14	QTD-2F02-1400-HP600	30573074
14,10	14	QTD-2F02-1410-HP600	30646120
14,20	14	QTD-2F02-1420-HP600	30630410
14,30	14	QTD-2F02-1430-HP600	30646122
14,40	14	QTD-2F02-1440-HP600	30646123
14,50	14,5	QTD-2F02-1450-HP600	30573075
14,60	14,5	QTD-2F02-1460-HP600	30646124
14,70	14,5	QTD-2F02-1470-HP600	30573076
14,75	14,5	QTD-2F02-1475-HP600	30573077
14,80	14,5	QTD-2F02-1480-HP600	30646125
15,00	15	QTD-2F02-1500-HP600	30573078
15,20	15	QTD-2F02-1520-HP600	30646128
15,25	15	QTD-2F02-1525-HP600	30573079
15,40	15	QTD-2F02-1540-HP600	30646130
15,50	15	QTD-2F02-1550-HP600	30573080
15,60	15	QTD-2F02-1560-HP600	30646131
15,70	15	QTD-2F02-1570-HP600	30573081
15,80	15	QTD-2F02-1580-HP600	30646132
16,00	16	QTD-2F02-1600-HP600	30573083
16,10	16	QTD-2F02-1610-HP600	30573086
16,20	16	QTD-2F02-1620-HP600	30646134
16,30	16	QTD-2F02-1630-HP600	30646135
16,40	16	QTD-2F02-1640-HP600	30646136
16,50	16	QTD-2F02-1650-HP600	30573088
16,60	16	QTD-2F02-1660-HP600	30646137
16,70	16	QTD-2F02-1670-HP600	30573089

d ₁ da 16,75 a 23,75			
d ₁ h7	Dimensioni supporto D	Specifiche	Codice
16,75	16	QTD-2F02-1675-HP600	30573090
16,80	16	QTD-2F02-1680-HP600	30646138
16,90	16	QTD-2F02-1690-HP600	30646139
17,00	17	QTD-2F02-1700-HP600	30573091
17,30	17	QTD-2F02-1730-HP600	30646142
17,40	17	QTD-2F02-1740-HP600	30646143
17,50	17	QTD-2F02-1750-HP600	30573092
17,70	17	QTD-2F02-1770-HP600	30573093
17,90	17	QTD-2F02-1790-HP600	30646146
18,00	18	QTD-2F02-1800-HP600	30573094
18,50	18	QTD-2F02-1850-HP600	30573096
18,60	18	QTD-2F02-1860-HP600	30646151
18,70	18	QTD-2F02-1870-HP600	30573097
19,00	19	QTD-2F02-1900-HP600	30573098
19,40	19	QTD-2F02-1940-HP600	30573101
19,50	19	QTD-2F02-1950-HP600	30573102
19,60	19	QTD-2F02-1960-HP600	30646157
19,70	19	QTD-2F02-1970-HP600	30573103
19,75	19	QTD-2F02-1975-HP600	30573104
19,80	19	QTD-2F02-1980-HP600	30646158
19,90	19	QTD-2F02-1990-HP600	30646159
20,00	20	QTD-2F02-2000-HP600	30573105
20,40	20	QTD-2F02-2040-HP600	30573106
20,50	20	QTD-2F02-2050-HP600	30573107
21,00	21	QTD-2F02-2100-HP600	30573110
21,50	21	QTD-2F02-2150-HP600	30573111
21,70	21	QTD-2F02-2170-HP600	30573112
22,00	22	QTD-2F02-2200-HP600	30573113
22,25	22	QTD-2F02-2225-HP600	30573114
22,70	22	QTD-2F02-2270-HP600	30573117
23,00	23	QTD-2F02-2300-HP600	30573119
23,50	23	QTD-2F02-2350-HP600	30573121
23,75	23	QTD-2F02-2375-HP600	30573124

Prosegue alla pagina seguente.

Inseri QTD in metallo duro integrale, adduzione interna del refrigerante - tipo 02

d ₁ da 24,00 a 27,00			
d ₁ h7	Dimensioni supporto D	Specifiche	Codice
24,00	24	QTD-2F02-2400-HP600	30573125
24,40	24	QTD-2F02-2440-HP600	30665151
24,50	24	QTD-2F02-2450-HP600	30573126
24,70	24	QTD-2F02-2470-HP600	30573127
24,75	24	QTD-2F02-2475-HP600	30573128
25,00	25	QTD-2F02-2500-HP600	30573129
25,50	25	QTD-2F02-2550-HP600	30573131
25,70	25	QTD-2F02-2570-HP600	30573132
26,00	26	QTD-2F02-2600-HP600	30573133
26,50	26	QTD-2F02-2650-HP600	30573134
27,00	27	QTD-2F02-2700-HP600	30573135

d ₁ da 27,50 a 40,00			
d ₁ h7	Dimensioni supporto D	Specifiche	Codice
27,50	27	QTD-2F02-2750-HP600	30573136
28,00	28	QTD-2F02-2800-HP600	30573138
29,00	29	QTD-2F02-2900-HP600	30573141
29,50	29	QTD-2F02-2950-HP600	30573142
30,00	30	QTD-2F02-3000-HP600	30573143
30,75	30	QTD-2F02-3075-HP600	30573146
33,00	33	QTD-2F02-3300-HP600	30649662
36,00	36	QTD-2F02-3600-HP600	30649665
37,00	37	QTD-2F02-3700-HP600	30649666
40,00	39	QTD-2F02-4000-HP600	30657246

Caratteristiche configurabili



Diametro:
Diametro a libera scelta a passi da 0,01 mm

Specifiche:
QTD-2F02-[diametro]-HP600

Dimensioni serie configurabile

d ₁ min.	d ₁ max.
9,00	50,00

Esempio:

QTD-2F02-1401-HP600

Diametro utensile d₁ = 14,01 mm

Inserti QTD

In metallo duro integrale, adduzione interna del refrigerante
Tipo 04 - Iron

Versione:

Diametro punta: 9,00 - 50,00 mm
Tolleranza di foratura: \geq IT 10
Materiale da taglio: HP240
Numero di taglienti: 2
Numero margini di guida: 2
Angolo tra taglienti: 135°

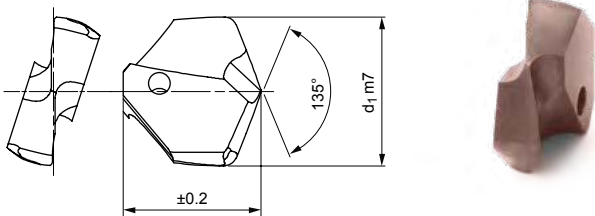

Serie selezionata per il magazzino

d ₁ da 12,00 a 23,00			
d ₁ m7	Dimensioni supporto D	Specifiche	Codice
12,00	12	QTD-2F04-1200-HP240	30615805
14,00	14	QTD-2F04-1400-HP240	30612900
14,50	14,5	QTD-2F04-1450-HP240	30612901
17,00	17	QTD-2F04-1700-HP240	30612915
17,50	17	QTD-2F04-1750-HP240	30612916
18,00	18	QTD-2F04-1800-HP240	30612918
19,00	19	QTD-2F04-1900-HP240	30612922
19,10	19	QTD-2F04-1910-HP240	30646366
19,50	19	QTD-2F04-1950-HP240	30612926
20,50	20	QTD-2F04-2050-HP240	30612931
21,00	21	QTD-2F04-2100-HP240	30612934
21,50	21	QTD-2F04-2150-HP240	30612935
22,00	22	QTD-2F04-2200-HP240	30612937
23,00	23	QTD-2F04-2300-HP240	30612943

d ₁ da 23,50 a 33,00			
d ₁ m7	Dimensioni supporto D	Specifiche	Codice
23,50	23	QTD-2F04-2350-HP240	30612945
24,00	24	QTD-2F04-2400-HP240	30612949
24,50	24	QTD-2F04-2450-HP240	30612950
25,00	25	QTD-2F04-2500-HP240	30612953
25,70	25	QTD-2F04-2570-HP240	30612956
26,00	26	QTD-2F04-2600-HP240	30612957
26,50	26	QTD-2F04-2650-HP240	30612958
28,00	28	QTD-2F04-2800-HP240	30612962
28,50	28	QTD-2F04-2850-HP240	30612964
29,00	29	QTD-2F04-2900-HP240	30612965
29,50	29	QTD-2F04-2950-HP240	30612966
30,00	30	QTD-2F04-3000-HP240	30612967
31,00	31	QTD-2F04-3100-HP240	30612971
33,00	33	QTD-2F04-3300-HP240	30649674

Caratteristiche configurabili



Diametro:
Diametro a libera scelta a passi da 0,01 mm

Specifiche:
QTD-2F02-[diametro]-HP600

Dimensioni serie configurabile

d ₁ min.	d ₁ max.
9,00	50,00

Esempio:

QTD-2F02-1401-HP600

Diametro utensile d₁ = 14,01 mm

Misure in mm.

Per i parametri di lavorazione consigliati, vedere la fine del capitolo.

Versioni speciali e altri rivestimenti disponibili su richiesta.

Inserti QTD

In metallo duro integrale, adduzione interna del refrigerante
Tipo 03 - Alu

Versione:

Diametro punta: 9,00 - 50,00 mm
Tolleranza di foratura: \geq IT 10
Materiale da taglio: HU310
Numero di taglienti: 2
Numero margini di guida: 2
Angolo tra taglienti: 135°

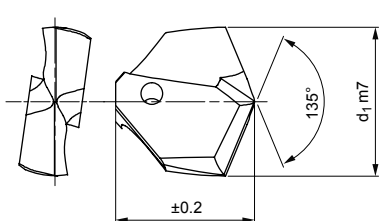

Serie selezionata per il magazzino

d ₁ da 13,00 a 20,50			
d ₁ m7	Dimensioni supporto D	Specifiche	Codice
13,00	13	QTD-2F03-1300-HU310	30612819
13,50	13,5	QTD-2F03-1350-HU310	30612820
14,00	14	QTD-2F03-1400-HU310	30612822
14,50	14,5	QTD-2F03-1450-HU310	30612823
15,00	15	QTD-2F03-1500-HU310	30612826
15,50	15	QTD-2F03-1550-HU310	30612828
16,00	16	QTD-2F03-1600-HU310	30612830
17,00	17	QTD-2F03-1700-HU310	30612837
17,50	17	QTD-2F03-1750-HU310	30612838
18,25	18	QTD-2F03-1825-HU310	30612841
18,50	18	QTD-2F03-1850-HU310	30612842
19,00	19	QTD-2F03-1900-HU310	30612844
20,00	20	QTD-2F03-2000-HU310	30612851
20,50	20	QTD-2F03-2050-HU310	30612853

d ₁ da 21,00 a 36,00			
d ₁ m7	Dimensioni supporto D	Specifiche	Codice
21,00	21	QTD-2F03-2100-HU310	30612856
22,00	22	QTD-2F03-2200-HU310	30612859
22,50	22	QTD-2F03-2250-HU310	30612862
23,00	23	QTD-2F03-2300-HU310	30612865
23,50	23	QTD-2F03-2350-HU310	30612867
24,00	24	QTD-2F03-2400-HU310	30612871
24,50	24	QTD-2F03-2450-HU310	30612872
25,00	25	QTD-2F03-2500-HU310	30612875
26,00	26	QTD-2F03-2600-HU310	30612879
27,00	27	QTD-2F03-2700-HU310	30612881
29,50	29	QTD-2F03-2950-HU310	30612888
30,00	30	QTD-2F03-3000-HU310	30612889
34,00	34	QTD-2F03-3400-HU310	30649669
36,00	36	QTD-2F03-3600-HU310	30649671

Caratteristiche configurabili



Diametro:
Diametro a libera scelta a passi da 0,01 mm

Specifiche:
QTD-2F03-[diametro]-HU310

Dimensioni serie configurabile

d ₁ min.	d ₁ max.
9,00	50,00

Esempio:

QTD-2F02-1401-HU310

Diametro utensile d₁ = 14,01 mm

Misure in mm.

Per i parametri di lavorazione consigliati, vedere la fine del capitolo.

Versioni speciali e altri rivestimenti disponibili su richiesta.

Supporto per inserto QTS

Con sede a prisma per inserti QTD
QTS100S, adduzione interna del refrigerante

Versione:

Per diametro:

9,00 - 50,99 mm

Forma del codolo:

secondo ISO 9766

Sistema di cambio:

sede a prisma, possibilità di cambiare i taglienti direttamente sulla macchina

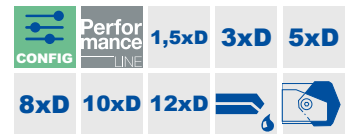
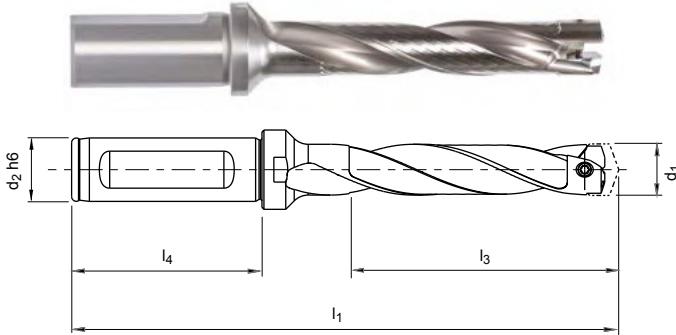

Serie selezionata per il magazzino

Dimensioni supporto D	Dimensioni				Specifiche	Codice	
	Range di diametro Inserto d ₁	d ₂ h6	l ₁	l ₃			l ₄
9,00	9,00 - 9,49	12	110	48	45	QTS100S-0900-DR05-ZYL12-MN	30605484
9,50	9,50 - 9,99	12	113	50	45	QTS100S-0950-DR05-ZYL12-MN	30605485
10,00	10,00 - 10,49	16	99	32	48	QTS100S-1000-DR03-ZYL16-MN	30605476
10,00	10,00 - 10,49	16	120	53	48	QTS100S-1000-DR05-ZYL16-MN	30605486
10,50	10,50 - 10,99	16	122	55	48	QTS100S-1050-DR05-ZYL16-MN	30605487
11,00	11,00 - 11,49	16	126	58	48	QTS100S-1100-DR05-ZYL16-MN	30605488
11,00	11,00 - 11,49	16	160	92	48	QTS100S-1100-DR08-ZYL16-MN	30605498
11,50	11,50 - 11,99	16	105	36	48	QTS100S-1150-DR03-ZYL16-MN	30605479
12,00	12,00 - 12,49	16	107	38	48	QTS100S-1200-DR03-ZYL16-MN	30605480
12,00	12,00 - 12,49	16	132	63	48	QTS100S-1200-DR05-ZYL16-MN	30605490
12,00	12,00 - 12,49	16	169	100	48	QTS100S-1200-DR08-ZYL16-MN	30605500
12,50	12,50 - 12,99	16	109	39	48	QTS100S-1250-DR03-ZYL16-MN	30605481
12,50	12,50 - 12,99	16	135	65	48	QTS100S-1250-DR05-ZYL16-MN	30605491
12,50	12,50 - 12,99	16	174	104	48	QTS100S-1250-DR08-ZYL16-MN	30605501
13,00	13,00 - 13,49	16	112	41	48	QTS100S-1300-DR03-ZYL16-MN	30572922
13,00	13,00 - 13,49	16	138	68	48	QTS100S-1300-DR05-ZYL16-MN	30572945
13,00	13,00 - 13,49	16	178	108	48	QTS100S-1300-DR08-ZYL16-MN	30572967
13,00	13,00 - 13,49	16	232	162	48	QTS100S-1300-DR12-ZYL16-MN	30598728
13,50	13,50 - 13,99	16	211	140	48	QTS100S-1350-DR10-ZYL16-MN	30826051
13,50	13,50 - 13,99	16	239	168	48	QTS100S-1350-DR12-ZYL16-MN	30598729
14,00	14,00 - 14,49	16	116	44	48	QTS100S-1400-DR03-ZYL16-MN	30572924
14,00	14,00 - 14,49	16	144	73	48	QTS100S-1400-DR05-ZYL16-MN	30572947
14,00	14,00 - 14,49	16	187	116	48	QTS100S-1400-DR08-ZYL16-MN	30572970
14,00	14,00 - 14,49	16	245	174	48	QTS100S-1400-DR12-ZYL16-MN	30598730
14,50	14,50 - 14,99	16	95	23	48	QTS100S-1450-DR01-ZYL16-MN	30572903
14,50	14,50 - 14,99	16	147	75	48	QTS100S-1450-DR05-ZYL16-MN	30572948
15,00	15,00 - 15,99	20	124	48	50	QTS100S-1500-DR03-ZYL20-MN	30572926
15,00	15,00 - 15,99	20	155	80	50	QTS100S-1500-DR05-ZYL20-MN	30572949
15,00	15,00 - 15,99	20	203	128	50	QTS100S-1500-DR08-ZYL20-MN	30572972
15,00	15,00 - 15,99	20	237	162	50	QTS100S-1500-DR10-ZYL20-MN	30826054
15,00	15,00 - 15,99	20	267	192	50	QTS100S-1500-DR12-ZYL20-MN	30598732
16,00	16,00 - 16,99	20	102	26	50	QTS100S-1600-DR01-ZYL20-MN	30572905
16,00	16,00 - 16,99	20	128	51	50	QTS100S-1600-DR03-ZYL20-MN	30572927
16,00	16,00 - 16,99	20	161	85	50	QTS100S-1600-DR05-ZYL20-MN	30572950

Supporto per inserto QTS | QTS100, adduzione interna del refrigerante

Dimensioni						Specifiche	Codice
Dimensioni supporto D	Range di diametro Inserto d ₁	d ₂ h6	l ₁	l ₃	l ₄		
16,00	16,00 - 16,99	20	212	136	50	QTS100S-1600-DR08-ZYL20-MN	30572973
16,00	16,00 - 16,99	20	246	170	50	QTS100S-1600-DR10-ZYL20-MN	30826055
17,00	17,00 - 17,99	20	105	27	50	QTS100S-1700-DR01-ZYL20-MN	30572906
17,00	17,00 - 17,99	20	132	54	50	QTS100S-1700-DR03-ZYL20-MN	30572928
17,00	17,00 - 17,99	20	168	90	50	QTS100S-1700-DR05-ZYL20-MN	30572951
17,00	17,00 - 17,99	20	222	144	50	QTS100S-1700-DR08-ZYL20-MN	30572974
17,00	17,00 - 17,99	20	258	180	50	QTS100S-1700-DR10-ZYL20-MN	30826056
17,00	17,00 - 17,99	20	294	216	50	QTS100S-1700-DR12-ZYL20-MN	30598734
18,00	18,00 - 18,99	25	142	57	56	QTS100S-1800-DR03-ZYL25-MN	30572929
18,00	18,00 - 18,99	25	180	95	56	QTS100S-1800-DR05-ZYL25-MN	30572952
18,00	18,00 - 18,99	25	237	152	56	QTS100S-1800-DR08-ZYL25-MN	30572975
18,00	18,00 - 18,99	25	313	228	56	QTS100S-1800-DR12-ZYL25-MN	30598735
19,00	19,00 - 19,99	25	116	30	56	QTS100S-1900-DR01-ZYL25-MN	30572908
19,00	19,00 - 19,99	25	146	60	56	QTS100S-1900-DR03-ZYL25-MN	30572930
19,00	19,00 - 19,99	25	186	100	56	QTS100S-1900-DR05-ZYL25-MN	30572953
19,00	19,00 - 19,99	25	246	160	56	QTS100S-1900-DR08-ZYL25-MN	30572976
20,00	20,00 - 20,99	25	151	63	56	QTS100S-2000-DR03-ZYL25-MN	30572931
20,00	20,00 - 20,99	25	192	105	56	QTS100S-2000-DR05-ZYL25-MN	30572954
20,00	20,00 - 20,99	25	255	168	56	QTS100S-2000-DR08-ZYL25-MN	30572977
20,00	20,00 - 20,99	25	297	210	56	QTS100S-2000-DR10-ZYL25-MN	30826059
20,00	20,00 - 20,99	25	339	252	56	QTS100S-2000-DR12-ZYL25-MN	30598737
21,00	21,00 - 21,99	25	121	33	56	QTS100S-2100-DR01-ZYL25-MN	30572910
21,00	21,00 - 21,99	25	155	66	56	QTS100S-2100-DR03-ZYL25-MN	30572932
21,00	21,00 - 21,99	25	198	110	56	QTS100S-2100-DR05-ZYL25-MN	30572955
21,00	21,00 - 21,99	25	264	176	56	QTS100S-2100-DR08-ZYL25-MN	30572978
21,00	21,00 - 21,99	25	308	220	56	QTS100S-2100-DR10-ZYL25-MN	30826060
22,00	22,00 - 22,99	25	125	35	56	QTS100S-2200-DR01-ZYL25-MN	30572911
22,00	22,00 - 22,99	25	159	69	56	QTS100S-2200-DR03-ZYL25-MN	30572933
22,00	22,00 - 22,99	25	205	115	56	QTS100S-2200-DR05-ZYL25-MN	30572956
22,00	22,00 - 22,99	25	274	184	56	QTS100S-2200-DR08-ZYL25-MN	30572979
23,00	23,00 - 23,99	25	127	36	56	QTS100S-2300-DR01-ZYL25-MN	30572912
23,00	23,00 - 23,99	25	211	120	56	QTS100S-2300-DR05-ZYL25-MN	30572957
23,00	23,00 - 23,99	25	379	288	56	QTS100S-2300-DR12-ZYL25-MN	30598740
24,00	24,00 - 24,99	32	171	75	60	QTS100S-2400-DR03-ZYL32-MN	30572935
24,00	24,00 - 24,99	32	221	125	60	QTS100S-2400-DR05-ZYL32-MN	30572958
24,00	24,00 - 24,99	32	296	200	60	QTS100S-2400-DR08-ZYL32-MN	30572981
24,00	24,00 - 24,99	32	396	300	60	QTS100S-2400-DR12-ZYL32-MN	30598741
25,00	25,00 - 25,99	32	136	39	60	QTS100S-2500-DR01-ZYL32-MN	30572914
25,00	25,00 - 25,99	32	176	78	60	QTS100S-2500-DR03-ZYL32-MN	30572937
25,00	25,00 - 25,99	32	227	130	60	QTS100S-2500-DR05-ZYL32-MN	30572959
25,00	25,00 - 25,99	32	305	208	60	QTS100S-2500-DR08-ZYL32-MN	30572982
25,00	25,00 - 25,99	32	409	312	60	QTS100S-2500-DR12-ZYL32-MN	30598742
26,00	26,00 - 26,99	32	139	41	60	QTS100S-2600-DR01-ZYL32-MN	30572915
26,00	26,00 - 26,99	32	180	81	60	QTS100S-2600-DR03-ZYL32-MN	30572938
26,00	26,00 - 26,99	32	233	135	60	QTS100S-2600-DR05-ZYL32-MN	30572960
26,00	26,00 - 26,99	32	314	216	60	QTS100S-2600-DR08-ZYL32-MN	30572983
26,00	26,00 - 26,99	32	368	270	60	QTS100S-2600-DR10-ZYL32-MN	30826065
27,00	27,00 - 27,99	32	184	84	60	QTS100S-2700-DR03-ZYL32-MN	30572939
27,00	27,00 - 27,99	32	324	224	60	QTS100S-2700-DR08-ZYL32-MN	30572984
28,00	28,00 - 28,99	32	188	87	60	QTS100S-2800-DR03-ZYL32-MN	30572940
28,00	28,00 - 28,99	32	246	145	60	QTS100S-2800-DR05-ZYL32-MN	30572962
28,00	28,00 - 28,99	32	449	348	60	QTS100S-2800-DR12-ZYL32-MN	30598745
29,00	29,00 - 29,99	32	402	300	60	QTS100S-2900-DR10-ZYL32-MN	30826068
30,00	30,00 - 30,99	32	197	93	60	QTS100S-3000-DR03-ZYL32-MN	30572942
30,00	30,00 - 30,99	32	351	248	60	QTS100S-3000-DR08-ZYL32-MN	30572987
30,00	30,00 - 30,99	32	413	310	60	QTS100S-3000-DR10-ZYL32-MN	30826069

Supporto per inserto QTS | QTS100, adduzione interna del refrigerante

Dimensioni supporto D	Dimensioni					Specifiche	Codice
	Range di diametro Inserto d ₁	d ₂ h6	l ₁	l ₃	l ₄		
30,00	30,00 - 30,99	32	475	372	60	QTS100S-3000-DR12-ZYL32-MN	30598747
31,00	31,00 - 31,99	32	264	160	60	QTS100S-3100-DR05-ZYL32-MN	30572965
32,00	32,00 - 32,99	32	271	165	60	QTS100S-3200-DR05-ZYL32-MN	30572966
32,00	32,00 - 32,99	32	436	330	60	QTS100S-3200-DR10-ZYL32-MN	30826071
32,00	32,00 - 32,99	32	502	396	60	QTS100S-3200-DR12-ZYL32-MN	30598749
33,00	33,00 - 33,99	32	209	102	60	QTS100S-3300-DR03-ZYL32-MN	30639167
34,00	34,00 - 34,99	32	283	175	60	QTS100S-3400-DR05-ZYL32-MN	30639172
35,00	35,00 - 35,99	32	218	108	60	QTS100S-3500-DR03-ZYL32-MN	30639169
36,00	36,00 - 36,99	32	222	111	60	QTS100S-3600-DR03-ZYL32-MN	30639170
37,00	37,00 - 38,99	40	318	195	70	QTS100S-3700-DR05-ZYL40-MN	30650288
39,00	39,00 - 40,99	40	249	123	70	QTS100S-3900-DR03-ZYL40-MN	30650284
41,00	41,00 - 42,99	40	257	129	70	QTS100S-4100-DR03-ZYL40-MN	30650285

Caratteristiche configurabili



Versione lunghezza:
DR01 | DR03 | DR05 | DR08 | DR10 | DR12



Specifiche:
QTS100S-3500-[versione lunghezza]-ZYL32-MN

Esempio:

QTS100S-3500-DR10-ZYL32-MN

Versione lunghezza 10xD

Dimensioni serie configurabile

Dimensioni supporto D	Range di diametro inserto d ₁	d ₂ h6	l ₄	DR01		DR03		DR05		DR08		DR10		DR12		Specifiche
				l ₁	l ₃	l ₁	l ₃	l ₁	l ₃	l ₁	l ₃	l ₁	l ₃	l ₁	l ₃	
9	9,00 - 9,49	12	45	77	15	92	29	110	48	138	76	-	-	-	-	QTS100S-0900-[versione lunghezza]-ZYL12-MN
9,5	9,50 - 9,99	12	45	78	15	93	30	113	50	143	80	-	-	-	-	QTS100S-0950-[versione lunghezza]-ZYL12-MN
10	10,00 - 10,49	16	48	83	16	99	32	120	53	151	84	-	-	-	-	QTS100S-1000-[versione lunghezza]-ZYL16-MN
10,5	10,50 - 10,99	16	48	84	17	101	33	122	55	155	88	-	-	-	-	QTS100S-1050-[versione lunghezza]-ZYL16-MN
11	11,00 - 11,49	16	48	86	18	103	35	126	58	160	92	-	-	-	-	QTS100S-1100-[versione lunghezza]-ZYL16-MN
11,5	11,50 - 11,99	16	48	86	18	105	36	128	60	164	96	-	-	-	-	QTS100S-1150-[versione lunghezza]-ZYL16-MN
12	12,00 - 12,49	16	48	88	19	107	38	132	63	169	100	-	-	-	-	QTS100S-1200-[versione lunghezza]-ZYL16-MN
12,5	12,50 - 12,99	16	48	90	20	109	39	135	65	174	104	-	-	-	-	QTS100S-1250-[versione lunghezza]-ZYL16-MN
13	13,00 - 13,49	16	48	91	21	112	41	138	68	178	108	135	205	232	162	QTS100S-1300-[versione lunghezza]-ZYL16-MN
13,5	13,50 - 13,99	16	48	92	21	113	42	141	70	183	112	140	211	239	168	QTS100S-1350-[versione lunghezza]-ZYL16-MN
14	14,00 - 14,49	16	48	93	22	116	44	144	73	187	116	145	216	245	174	QTS100S-1400-[versione lunghezza]-ZYL16-MN
14,5	14,50 - 14,99	16	48	95	23	117	45	147	75	192	120	150	222	252	180	QTS100S-1450-[versione lunghezza]-ZYL16-MN
15	15,00 - 15,99	20	50	99	24	124	48	155	80	203	128	162	237	267	192	QTS100S-1500-[versione lunghezza]-ZYL20-MN
16	16,00 - 16,99	20	50	102	26	128	51	161	85	212	136	170	246	280	204	QTS100S-1600-[versione lunghezza]-ZYL20-MN
17	17,00 - 17,99	20	50	105	27	132	54	168	90	222	144	180	258	294	216	QTS100S-1700-[versione lunghezza]-ZYL20-MN
18	18,00 - 18,99	25	56	114	29	142	57	180	95	237	152	190	275	313	228	QTS100S-1800-[versione lunghezza]-ZYL25-MN
19	19,00 - 19,99	25	56	116	30	146	60	186	100	246	160	200	286	326	240	QTS100S-1900-[versione lunghezza]-ZYL25-MN
20	20,00 - 20,99	25	56	119	32	151	63	192	105	255	168	210	297	339	252	QTS100S-2000-[versione lunghezza]-ZYL25-MN
21	21,00 - 21,99	25	56	121	33	155	66	198	110	264	176	220	308	352	264	QTS100S-2100-[versione lunghezza]-ZYL25-MN
22	22,00 - 22,99	25	56	125	35	159	69	205	115	274	184	230	320	366	276	QTS100S-2200-[versione lunghezza]-ZYL25-MN
23	23,00 - 23,99	25	56	127	36	163	72	211	120	283	192	240	331	379	288	QTS100S-2300-[versione lunghezza]-ZYL25-MN
24	24,00 - 24,99	32	60	134	38	171	75	221	125	296	200	250	346	396	300	QTS100S-2400-[versione lunghezza]-ZYL32-MN
25	25,00 - 25,99	32	60	136	39	176	78	227	130	305	208	260	357	409	312	QTS100S-2500-[versione lunghezza]-ZYL32-MN
26	26,00 - 26,99	32	60	139	41	180	81	233	135	314	216	270	368	422	324	QTS100S-2600-[versione lunghezza]-ZYL32-MN
27	27,00 - 27,99	32	60	142	42	184	84	240	140	324	224	280	380	436	336	QTS100S-2700-[versione lunghezza]-ZYL32-MN

Prosegue alla pagina seguente.

Dimensioni serie configurabile

Dimen- sioni suppor- to D	Range di diame- tro inserto d ₁	d ₂ h ₆	l ₄	DR01		DR03		DR05		DR08		DR10		DR12		Specifiche
				l ₁	l ₃	l ₁	l ₃	l ₁	l ₃	l ₁	l ₃	l ₁	l ₃	l ₁	l ₃	
28	28,00 - 28,99	32	60	145	44	188	87	246	145	333	232	290	391	449	348	QTS100S-2800-[versione lunghezza]-ZYL32-MN
29	29,00 - 29,99	32	60	147	45	192	90	252	150	342	240	300	402	462	360	QTS100S-2900-[versione lunghezza]-ZYL32-MN
30	30,00 - 30,99	32	60	150	47	197	93	258	155	351	248	310	413	475	372	QTS100S-3000-[versione lunghezza]-ZYL32-MN
31	31,00 - 31,99	32	60	152	48	201	96	264	160	360	256	320	424	488	384	QTS100S-3100-[versione lunghezza]-ZYL32-MN
32	32,00 - 32,99	32	60	156	50	205	99	271	165	370	264	330	436	502	396	QTS100S-3200-[versione lunghezza]-ZYL32-MN
33	33,00 - 33,99	32	60	158	51	209	102	277	170	379	272	340	447	515	408	QTS100S-3300-[versione lunghezza]-ZYL32-MN
34	34,00 - 34,99	32	60	161	53	213	105	283	175	388	280	350	458	528	420	QTS100S-3400-[versione lunghezza]-ZYL32-MN
35	35,00 - 35,99	32	60	163	54	218	108	289	180	397	288	360	469	541	432	QTS100S-3500-[versione lunghezza]-ZYL32-MN
36	36,00 - 36,99	32	60	166	56	222	111	295	185	406	296	370	480	554	444	QTS100S-3600-[versione lunghezza]-ZYL32-MN
37	37,00 - 38,99	40	70	182	59	240	117	318	195	435	312	390	515	591	468	QTS100S-3700-[versione lunghezza]-ZYL40-MN
39	39,00 - 40,99	40	70	187	62	249	123	330	205	453	328	410	537	617	492	QTS100S-3900-[versione lunghezza]-ZYL40-MN
41	41,00 - 42,99	40	70	193	65	257	129	343	215	472	344	430	560	644	516	QTS100S-4100-[versione lunghezza]-ZYL40-MN
43	43,00 - 44,99	40	70	198	68	265	135	355	225	490	360	440	582	670	540	QTS100S-4300-[versione lunghezza]-ZYL40-MN
45	45,00 - 46,99	40	70	203	71	274	141	367	235	508	376	470	604	696	564	QTS100S-4500-[versione lunghezza]-ZYL40-MN
47	47,00 - 48,99	40	70	211	74	284	147	382	245	529	392	490	627	725	588	QTS100S-4700-[versione lunghezza]-ZYL40-MN
49	49,00 - 50,99	40	70	216	77	293	153	394	255	547	408	510	649	751	612	QTS100S-4900-[versione lunghezza]-ZYL40-MN

Misure in mm.

Versioni speciali disponibili su richiesta.

Parti di ricambio

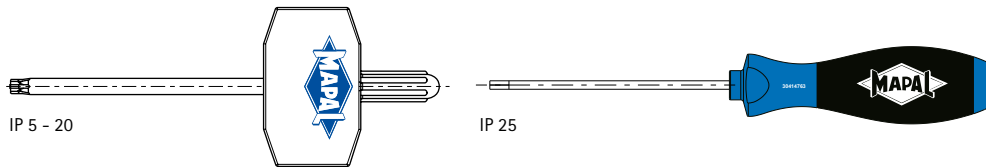

Cacciavite

Dimensioni Torx TORX PLUS®	Codice
5 IP	30584281
6 IP	30584282
7 IP	30584283
8 IP	30584284
9 IP	30584285
10 IP	30584286
15 IP	30584287
20 IP	30584288
25 IP	30414767

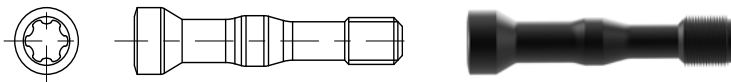

Vite di serraggio

Range di Ø	Misura TORX PLUS®	Codice	Specifiche	Coppia di serraggio [Nm]
8,00 - 8,99	5 IP	30604440	M1.2X7.5-TX5-IP	0,2
9,00 - 10,99	5 IP	30546309	M1.2X8.5-TX5-IP	0,2
11,00 - 12,99	6 IP	30604180	M1.6X10.5-TX6-IP	0,4
13,00 - 13,99	7 IP	30510826	M2x12-TX7-IP	0,6
14,00 - 15,99	8 IP	30510827	M2.2x13-TX8-IP	0,9
16,00 - 18,99	8 IP	30495432	M2.5x15-TX8-IP	1,2
19,00 - 21,99	9 IP	30510829	M3x18-TX9-IP	2,2
22,00 - 24,99	10 IP	30510830	M3.5x21-TX10-IP	3,3
25,00 - 27,99	15 IP	30510831	M4x24-TX15-IP	5,0
28,00 - 30,99	15 IP	30510832	M4.5x27-TX15-IP	5,7
31,00 - 32,99	20 IP	30510833	M5x30-TX20-IP	7,5
33,00 - 36,99	20 IP	30651830	M5X32-TX20-IP	7,5
37,00 - 44,99	25 IP	30651399	M6X35-TX25-IP	15,0
45,00 - 50,99	25 IP	30651510	M6X43-TX25-IP	15,0

Parametri di lavorazione consigliati per inserti QTD

Avanzamento e velocità di taglio

Tipo 01 – Steel

GTM*		Materiale	Resistenza/durezza [N/mm ²] [HRC]
P1	P1.1	Acciai da costruzione, automatici, da cementazione e da bonifica, non legati	< 700
	P1.2	Acciai da costruzione, automatici, da cementazione e da bonifica, non legati	< 1.200
P2	P2.1	Acciai da niturazione, da cementazione e da bonifica, legati	< 900
	P2.2	Acciai da niturazione, da cementazione e da bonifica, legati	< 1.400
P3	P3.1	Acciai per utensili, per cuscinetti volventi, armonici e per lavorazioni veloci**	< 800
	P3.2	Acciai per utensili, per cuscinetti volventi, armonici e per lavorazioni veloci**	< 1.000
P5	P5.1	Acciaio fuso	< 1.500
	P5.1	Acciaio fuso	< 1.500
K	K1.1	Ghisa con grafite lamellare (ghisa grigia), GJL	< 300
	K2.1	Ghisa con grafite sferoidale, GJS	< 500
	K2.2	Ghisa con grafite sferoidale, GJS	≤ 800
	K2.3	Ghisa con grafite sferoidale, GJS	> 800
	K3.1	Ghisa con grafite vermicolare, GJV; acciaio fuso malleabile, GJM	< 500
	K3.2	Ghisa con grafite vermicolare, GJV; acciaio fuso malleabile, GJM	> 500

Tipo 05 – Steel-Pyramid

GTM*		Materiale	Resistenza/durezza [N/mm ²] [HRC]
P1	P1.1	Acciai da costruzione, automatici, da cementazione e da bonifica, non legati	< 700
	P1.2	Acciai da costruzione, automatici, da cementazione e da bonifica, non legati	< 1.200
P2	P2.1	Acciai da niturazione, da cementazione e da bonifica, legati	< 900
	P2.2	Acciai da niturazione, da cementazione e da bonifica, legati	< 1.400
P3	P3.1	Acciai per utensili, per cuscinetti volventi, armonici e per lavorazioni veloci**	< 800
	P3.2	Acciai per utensili, per cuscinetti volventi, armonici e per lavorazioni veloci**	< 1.000
P5	P5.1	Acciaio fuso	< 1.500
	P5.1	Acciaio fuso	< 1.500
K	K1.1	Ghisa con grafite lamellare (ghisa grigia), GJL	< 300
	K2.1	Ghisa con grafite sferoidale, GJS	< 500
	K2.2	Ghisa con grafite sferoidale, GJS	≤ 800
K	K2.3	Ghisa con grafite sferoidale, GJS	> 800
	K2.3	Ghisa con grafite sferoidale, GJS	> 800

Tipo 10 – Uni, forma EK

GTM*		Materiale	Resistenza/durezza [N/mm ²] [HRC]
P1	P1.1	Acciai da costruzione, automatici, da cementazione e da bonifica, non legati	< 700
	P1.2	Acciai da costruzione, automatici, da cementazione e da bonifica, non legati	< 1200
P2	P2.1	Acciai da niturazione, da cementazione e da bonifica, legati	< 900
	P2.2	Acciai da niturazione, da cementazione e da bonifica, legati	< 1400
P3	P3.1	Acciai per utensili, per cuscinetti volventi, armonici e per lavorazioni veloci**	< 800
	P3.2	Acciai per utensili, per cuscinetti volventi, armonici e per lavorazioni veloci**	< 1000
P5	P5.1	Acciaio fuso	< 1500
	P5.1	Acciaio fuso	< 1500
K	K1.1	Ghisa con grafite lamellare (ghisa grigia), GJL	< 300
	K2.1	Ghisa con grafite sferoidale, GJS	< 500

* Gruppi di materiale MAPAL

** Qualora la somma dei componenti di lega Cr, Mo, Ni, V, W equivalesse a > 8%, selezionare il gruppo di materiale MAPAL immediatamente superiore.

	Velocità di taglio v_c [m/min]				Avanzamento f [mm] con diametro punta					
	Adduzione interna del refrigerante	Raffreddamento esterno	MQL	Aria	8,00	11,50	16,50	24,00	34,50	50,00
	100	90	90		0,20	0,26	0,31	0,36	0,38	0,39
	90	75	75		0,25	0,32	0,39	0,45	0,47	0,49
	100	85	85		0,24	0,30	0,37	0,43	0,45	0,46
	70	60	60		0,19	0,24	0,29	0,34	0,35	0,36
	75	65	65		0,22	0,27	0,33	0,38	0,40	0,42
	60	55	55		0,18	0,22	0,27	0,31	0,33	0,34
	60	45	50		0,14	0,18	0,21	0,24	0,25	0,26
	100	85	85		0,24	0,30	0,37	0,43	0,45	0,46
	95	70	70	70	0,25	0,33	0,41	0,47	0,49	0,51
	130	80	95	95	0,24	0,30	0,37	0,43	0,46	0,47
	80	60	60		0,21	0,26	0,32	0,37	0,39	0,40
	50	30	40		0,14	0,18	0,21	0,24	0,26	0,26
	70	65	65		0,22	0,28	0,35	0,40	0,42	0,43
	65	55	55		0,18	0,23	0,27	0,32	0,33	0,34

	Velocità di taglio v_c [m/min]				Avanzamento f [mm] con diametro punta					
	Adduzione interna del refrigerante	Raffreddamento esterno	MQL	Aria	14,00	16,50	19,50	23,00	27,00	32,00
	120	110	110		0,26	0,29	0,31	0,33	0,34	0,34
	110	90	90		0,33	0,36	0,38	0,41	0,42	0,43
	120	100	100		0,31	0,34	0,36	0,38	0,40	0,41
	90	80	80		0,28	0,30	0,33	0,35	0,36	0,37
	95	70	70	70	0,39	0,43	0,46	0,49	0,51	0,52
	110	70	85	85	0,36	0,40	0,43	0,45	0,47	0,48

	Velocità di taglio v_c [m/min]				Avanzamento f [mm] con diametro punta					
	Adduzione interna del refrigerante	Raffreddamento esterno	MQL	Aria	10,00	13,00	16,00	21,00	26,00	33,00
	120	110	110		0,22	0,25	0,28	0,31	0,34	0,35
	110	90	90		0,27	0,31	0,35	0,39	0,42	0,43
	120	100	100		0,25	0,29	0,33	0,37	0,40	0,41
	90	80	80		0,23	0,26	0,30	0,33	0,36	0,37
	95	70	70	70	0,31	0,36	0,42	0,47	0,51	0,52
	110	70	85	85	0,29	0,34	0,39	0,43	0,47	0,48

I parametri di lavorazione indicati sono valori orientativi.

I dati ottimali per la specifica applicazione devono essere rilevati eseguendo diversi tentativi o durante l'effettiva lavorazione.

Parametri di lavorazione consigliati per inserti QTD

Avanzamento e velocità di taglio

Tipo 02 - Inox

GTM*		Materiale	Resistenza/durezza [N/mm ²] [HRC]	
P	P1	P1.1 Acciai da costruzione, automatici, da cementazione e da bonifica, non legati	< 700	
		P1.2 Acciai da costruzione, automatici, da cementazione e da bonifica, non legati	< 1.200	
	P2	P2.1 Acciai da niturazione, da cementazione e da bonifica, legati	< 900	
		P2.2 Acciai da niturazione, da cementazione e da bonifica, legati	< 1.400	
	P3	P3.1 Acciai per utensili, per cuscinetti volventi, armonici e per lavorazioni veloci**	< 800	
		P3.2 Acciai per utensili, per cuscinetti volventi, armonici e per lavorazioni veloci**	< 1.000	
		P3.3 Acciai per utensili, per cuscinetti volventi, armonici e per lavorazioni veloci**	< 1.500	
	P4	P4.1 Acciai inossidabili, ferritici e martensitici		
	P5	P5.1 Acciaio fuso		
	P6	P6.1 Acciaio fuso, ferritico e martensitico		
M	M1	M1.1 Acciai inossidabili, austenitici	< 700	
		M1.2 Acciai inossidabili, ferritici/austenitici (Duplex)	< 1.000	
	M2	M2.1 Acciaio fuso inossidabile, austenitico	< 700	
	M3	M3.1 Acciaio fuso inossidabile, ferritico/austenitico (Duplex)	< 1.000	
K	K1	K1.1 Ghisa con grafite lamellare (ghisa grigia), GJL	< 300	
		K2.1 Ghisa con grafite sferoidale, GJS	< 500	
		K2.2 Ghisa con grafite sferoidale, GJS	≤ 800	
	K2	K2.3 Ghisa con grafite sferoidale, GJS	> 800	
		K3.1	Ghisa con grafite vermicolare, GJV; acciaio fuso malleabile, GJM	< 500
			K3.2 Ghisa con grafite vermicolare, GJV; acciaio fuso malleabile, GJM	> 500

Tipo 03 - Alu

GTM*		Materiale	Resistenza/durezza [N/mm ²] [HRC]
N	N1	N1.1 Alluminio, non legato e legato < 3% Si	
		N1.2 Alluminio, legato ≤ 7% Si	
		N1.3 Alluminio, legato > 7-12% Si	
		N1.4 Alluminio, legato > 12% Si	
	N2	N2.1 Rame, non legato e bassolegato	< 300
		N2.2 Rame, legato	> 300
		N2.3 Ottone, bronzo, ghisa rossa	< 1.200

Tipo 04 - Iron

GTM*		Materiale	Resistenza/durezza [N/mm ²] [HRC]	
K	K1	K1.1 Ghisa con grafite lamellare (ghisa grigia), GJL	< 300	
		K2.1 Ghisa con grafite sferoidale, GJS	< 500	
		K2.2 Ghisa con grafite sferoidale, GJS	≤ 800	
	K2	K2.3 Ghisa con grafite sferoidale, GJS	> 800	
		K3.1	Ghisa con grafite vermicolare, GJV; acciaio fuso malleabile, GJM	< 500
			K3.2 Ghisa con grafite vermicolare, GJV; acciaio fuso malleabile, GJM	> 500

* Gruppi di materiale MAPAL

** Qualora la somma dei componenti di lega Cr, Mo, Ni, V, W equivalesse a > 8%, selezionare il gruppo di materiale MAPAL immediatamente superiore.

	Velocità di taglio v_c [m/min]				Avanzamento f [mm] con diametro punta					
	Adduzione interna del refrigerante	Raffreddamento esterno	MQL	Aria	9,00	12,00	16,00	21,00	27,50	36,00
	100	90	90		0,19	0,23	0,27	0,30	0,32	0,33
	90	75	75		0,24	0,29	0,34	0,38	0,40	0,41
	100	85	85		0,23	0,27	0,32	0,36	0,38	0,39
	70	60	60		0,18	0,22	0,25	0,28	0,30	0,31
	75	65	65		0,20	0,24	0,29	0,32	0,34	0,35
	60	55	55		0,17	0,20	0,23	0,26	0,28	0,29
	60	45	50		0,13	0,16	0,18	0,20	0,21	0,22
	60	45	50		0,13	0,16	0,19	0,21	0,23	0,23
	100	85	85		0,23	0,27	0,32	0,36	0,38	0,39
	60	45	50		0,13	0,16	0,19	0,21	0,23	0,23
	55	35	35		0,15	0,18	0,22	0,24	0,26	0,27
	50	30	30		0,13	0,16	0,19	0,21	0,22	0,23
	55	35	35		0,15	0,18	0,22	0,24	0,26	0,27
	50	30	30		0,13	0,16	0,19	0,21	0,22	0,23
	110	75	75	75	0,27	0,34	0,40	0,45	0,49	0,50
	145	90	110	110	0,26	0,31	0,37	0,42	0,45	0,46
	90	70	70		0,22	0,27	0,32	0,36	0,38	0,39
	55	35	45		0,15	0,18	0,21	0,23	0,25	0,26
	80	70	70		0,24	0,29	0,34	0,38	0,41	0,42
	70	65	65		0,19	0,23	0,27	0,30	0,33	0,33

	Velocità di taglio v_c [m/min]				Avanzamento f [mm] con diametro punta					
	Adduzione interna del refrigerante	Raffreddamento esterno	MQL	Aria	9,00	12,00	16,00	21,00	27,50	36,00
	300	200	250		0,19	0,23	0,27	0,30	0,32	0,33
	250	180	200		0,25	0,30	0,35	0,40	0,43	0,43
	220	150	180		0,25	0,30	0,35	0,40	0,43	0,43
	180	120	150		0,25	0,30	0,35	0,40	0,43	0,43
	140	100			0,19	0,23	0,27	0,30	0,32	0,33
	120	90			0,25	0,30	0,35	0,40	0,43	0,43
	200	160	160	120	0,30	0,37	0,44	0,50	0,54	0,55

	Velocità di taglio v_c [m/min]				Avanzamento f [mm] con diametro punta					
	Adduzione interna del refrigerante	Raffreddamento esterno	MQL	Aria	9,00	12,00	16,00	21,00	27,50	36,00
	120	85	85	85	0,37	0,45	0,53	0,60	0,65	0,66
	160	100	120	120	0,34	0,42	0,49	0,55	0,59	0,61
	100	75	75		0,30	0,36	0,42	0,48	0,51	0,52
	60	40	50		0,20	0,24	0,28	0,31	0,34	0,34
	90	80	80		0,32	0,39	0,46	0,51	0,55	0,56
	80	70	70		0,26	0,31	0,36	0,40	0,43	0,44

I parametri di lavorazione indicati sono valori orientativi.

I dati ottimali per la specifica applicazione devono essere rilevati eseguendo diversi tentativi o durante l'effettiva lavorazione.

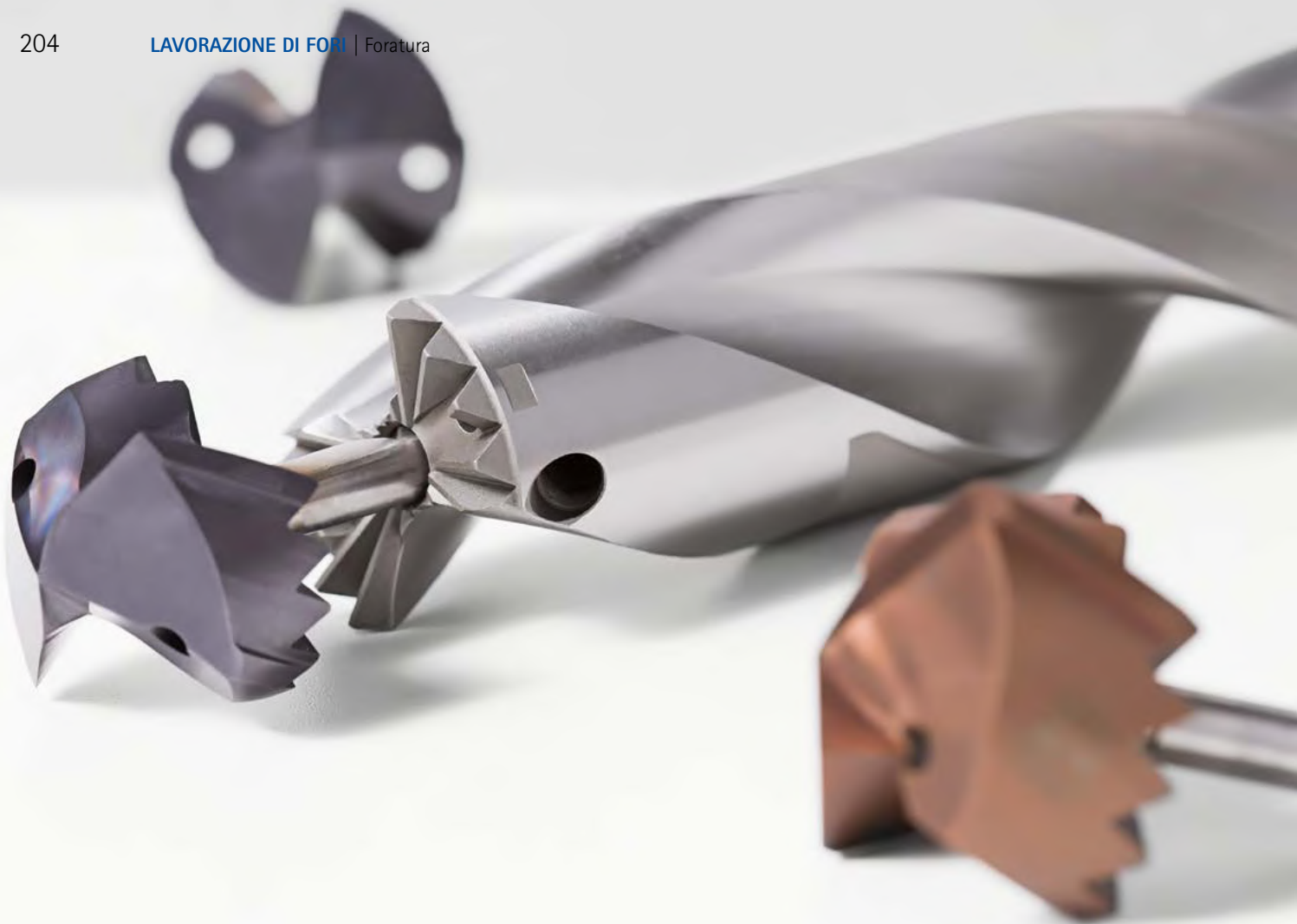

PUNTA AD INSERTO INTERCAMBIABILE TTD

Impiego di metallo duro ridotto al minimo, con stabilità e precisioni elevate

La punta ad inserto intercambiabile TTD ottiene lo stesso livello di prestazioni e di qualità delle punte in metallo duro integrale. Nel contempo, l'impiego ridotto di metallo duro proprio delle testine intercambiabili garantisce costi utensile più bassi.

Fulcro della punta ad inserto intercambiabile TTD è l'innesto TTS (Torque Transfer System), che garantisce un'estrema stabilità del colle-

gamento. Tra le caratteristiche principali figurano una trasmissione della coppia ottimale così come elevate precisioni di cambio e di concentricità.

Le serie standard della punta ad inserto intercambiabile TTD coprono le profondità di foratura 1xD, 3xD, 5xD, 8xD e 12xD. Con cinque diversi tipi di testine di foratura intercambiabili è possibile eseguire anche le operazioni di lavorazione più difficili praticamente su ogni materiale, in un range di diametro che va dai 12 ai 45 mm.

Le testine di foratura presentano una capacità di centratura ottimale e i trucioli vengono asportati in modo efficace lungo le apposite cavità del supporto TTS grazie alla particolare affilatura delle faccette. Inoltre, la geometria a tre o a quattro smussi agevola lo scorrimento nel foro. La combinazione di queste proprietà permette di ottenere elevate durate dell'utensile e di conseguire risultati di foratura di altissimo livello.

Caratteristiche utensile nel dettaglio

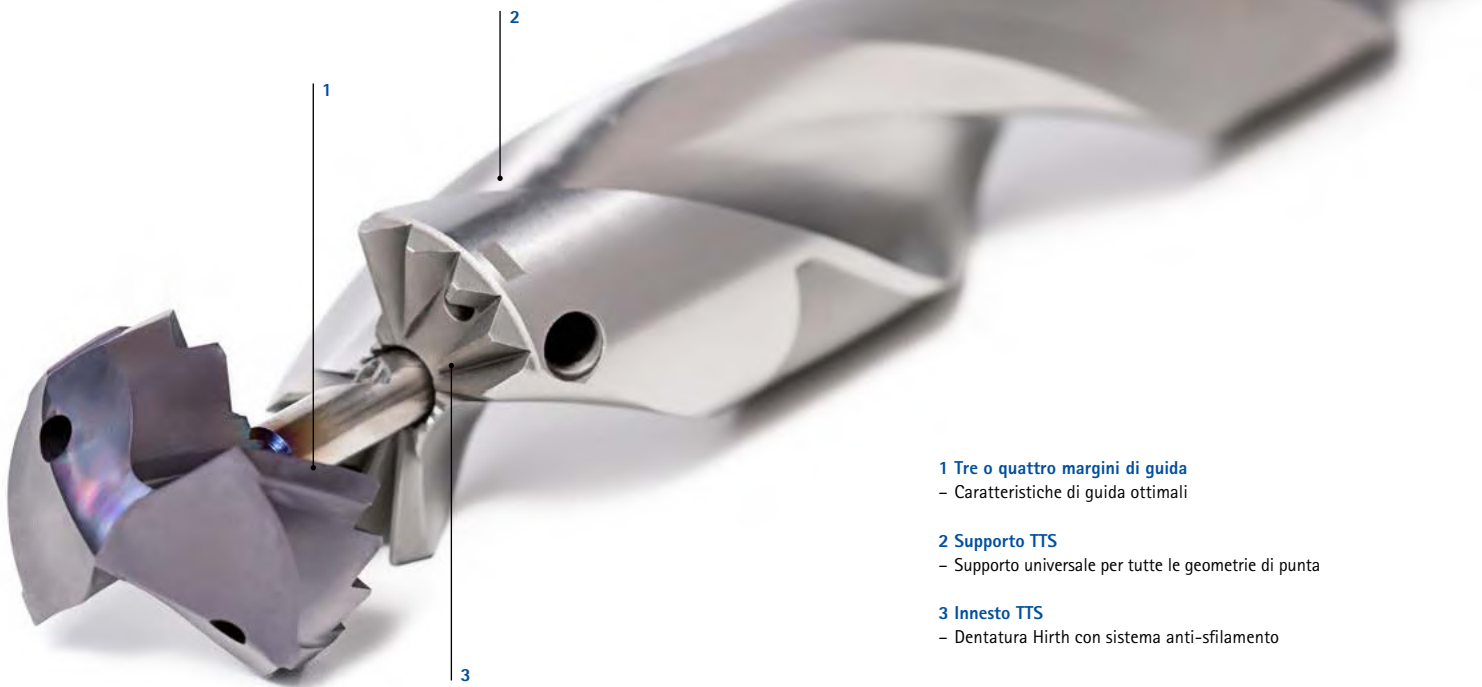

1 Tre o quattro margini di guida

- Caratteristiche di guida ottimali

2 Supporto TTS

- Supporto universale per tutte le geometrie di punta

3 Innesto TTS

- Dentatura Hirth con sistema anti-sfilamento



IN SINTESI

- Disponibile a magazzino
- Range di \varnothing da 12,00 a 45,00 mm
- Profondità di foratura 1 | 3 | 5 | 8 e 12xD
- Con adduzione interna del refrigerante
- Facile utilizzo
- Possibilità di sostituzione della testina direttamente nella macchina

CARATTERISTICHE E PRESTAZIONI

- Stesse prestazioni di una punta in metallo duro integrale
- Elevata precisione di concentricità
- Buona precisione di posizionamento
- Elevata trasmissione della coppia

VANTAGGI

- Possibilità di riaffilatura se necessario
- Cambio della testina con sistema anti-sfilamento
- Un solo supporto per diverse testine di foratura
- Possibilità di realizzare pressoché tutte le geometrie di foratura

Testina di foratura intercambiabile TTD

In metallo duro integrale, adduzione interna del refrigerante
Tipo 01P - Uni-Plus

Versione:

Diametro punta: 12,00 – 45,00 mm
Tolleranza di foratura: \geq IT 9
Materiale da taglio: HP358
Numero di taglienti: 2
Numero margini di guida: 4
Angolo tra taglienti: 140°

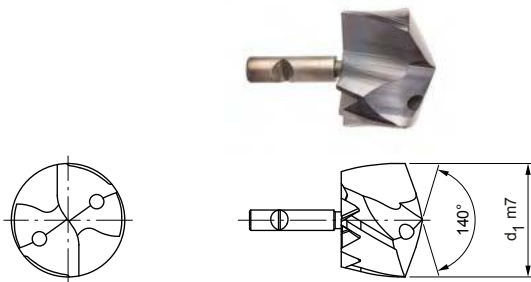

Serie selezionata per il magazzino

d ₁ da 12,00 a 21,00		
d ₁ m7	Specifiche	Codice
12,00	TTD-4F01P-1200-HP358	31164086
13,50	TTD-4F01P-1350-HP358	31164141
14,00	TTD-4F01P-1400-HP358	31164146
14,50	TTD-4F01P-1450-HP358	31164151
15,00	TTD-4F01P-1500-HP358	31164156
15,50	TTD-4F01P-1550-HP358	31164161
15,60	TTD-4F01P-1560-HP358	31164162
15,80	TTD-4F01P-1580-HP358	31164164
16,00	TTD-4F01P-1600-HP358	31164166
16,50	TTD-4F01P-1650-HP358	31164171
17,00	TTD-4F01P-1700-HP358	31164176
17,50	TTD-4F01P-1750-HP358	31164181
17,70	TTD-4F01P-1770-HP358	31164183
17,80	TTD-4F01P-1780-HP358	31164184
18,00	TTD-4F01P-1800-HP358	31164186
18,50	TTD-4F01P-1850-HP358	31164191
18,80	TTD-4F01P-1880-HP358	31164194
19,00	TTD-4F01P-1900-HP358	31164196
19,50	TTD-4F01P-1950-HP358	31164201
19,70	TTD-4F01P-1970-HP358	31164203
20,00	TTD-4F01P-2000-HP358	31164206
20,50	TTD-4F01P-2050-HP358	31164211
21,00	TTD-4F01P-2100-HP358	31164216

d ₁ da 21,50 a 40,00		
d ₁ m7	Specifiche	Codice
21,50	TTD-4F01P-2150-HP358	31164221
22,00	TTD-4F01P-2200-HP358	31164226
22,50	TTD-4F01P-2250-HP358	31164231
23,00	TTD-4F01P-2300-HP358	31164236
24,00	TTD-4F01P-2400-HP358	31164246
24,50	TTD-4F01P-2450-HP358	31164251
25,00	TTD-4F01P-2500-HP358	31164256
25,40	TTD-4F01P-2540-HP358	31164260
25,50	TTD-4F01P-2550-HP358	31164261
26,00	TTD-4F01P-2600-HP358	31164266
26,50	TTD-4F01P-2650-HP358	31164271
27,00	TTD-4F01P-2700-HP358	31164276
28,00	TTD-4F01P-2800-HP358	31164286
28,50	TTD-4F01P-2850-HP358	31164291
30,00	TTD-4F01P-3000-HP358	31164306
30,70	TTD-4F01P-3070-HP358	31164313
31,00	TTD-4F01P-3100-HP358	31164316
32,00	TTD-4F01P-3200-HP358	31164326
33,00	TTD-4F01P-3300-HP358	31164328
37,00	TTD-4F01P-3700-HP358	31164336
38,50	TTD-4F01P-3850-HP358	31164339
39,00	TTD-4F01P-3900-HP358	31164340
40,00	TTD-4F01P-4000-HP358	31164342

Caratteristiche configurabili



Diametro:
Diametro a libera scelta a passi da 0,01 mm



Specifiche:

TTD-4F01P-[diametro]-HP358

Dimensioni serie configurabile

d ₁ min.	d ₁ max.
12,00	45,00

Esempio:

TTD-4F01P-1401-HP358

Diametro utensile d₁ = 14,01 mm

Misure in mm.

Versioni speciali disponibili su richiesta.

Testina di foratura intercambiabile TTD

In metallo duro integrale, adduzione interna del refrigerante
Tipo 04 - Steel

Versione:

Diametro punta: 12,00 – 45,00 mm
Tolleranza di foratura: \geq IT 9
Materiale da taglio: HP358
Numero di taglienti: 2
Numero margini di guida: 3
Angolo tra taglienti: 138°

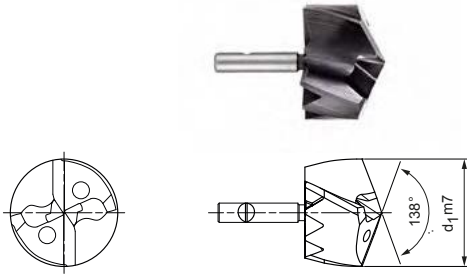

Serie selezionata per il magazzino

d ₁ da 12,00 a 17,00		
d ₁ m7	Specifiche	Codice
12,00	TTD-3F04-1200-HP358	30530406
12,10	TTD-3F04-1210-HP358	30596953
12,20	TTD-3F04-1220-HP358	30596954
12,50	TTD-3F04-1250-HP358	30530407
12,80	TTD-3F04-1280-HP358	30596958
13,00	TTD-3F04-1300-HP358	30530409
13,10	TTD-3F04-1310-HP358	30596960
13,20	TTD-3F04-1320-HP358	30596961
13,50	TTD-3F04-1350-HP358	30530410
14,00	TTD-3F04-1400-HP358	30530412
14,10	TTD-3F04-1410-HP358	30596967
14,20	TTD-3F04-1420-HP358	30596968
14,30	TTD-3F04-1430-HP358	30596969
14,40	TTD-3F04-1440-HP358	30596970
14,50	TTD-3F04-1450-HP358	30530413
14,70	TTD-3F04-1470-HP358	30530414
14,80	TTD-3F04-1480-HP358	30596972
15,00	TTD-3F04-1500-HP358	30530415
15,10	TTD-3F04-1510-HP358	30596974
15,20	TTD-3F04-1520-HP358	30596975
15,50	TTD-3F04-1550-HP358	30530416
15,70	TTD-3F04-1570-HP358	30530417
15,80	TTD-3F04-1580-HP358	30596979
16,00	TTD-3F04-1600-HP358	30530418
16,10	TTD-3F04-1610-HP358	30596981
16,20	TTD-3F04-1620-HP358	30596982
16,30	TTD-3F04-1630-HP358	30596983
16,40	TTD-3F04-1640-HP358	30596984
16,50	TTD-3F04-1650-HP358	30530419
16,60	TTD-3F04-1660-HP358	30596985
16,70	TTD-3F04-1670-HP358	30530420
16,80	TTD-3F04-1680-HP358	30596986
17,00	TTD-3F04-1700-HP358	30530421

d ₁ da 17,10 a 21,40		
d ₁ m7	Specifiche	Codice
17,10	TTD-3F04-1710-HP358	30596988
17,30	TTD-3F04-1730-HP358	30596990
17,50	TTD-3F04-1750-HP358	30530422
17,60	TTD-3F04-1760-HP358	30596992
17,70	TTD-3F04-1770-HP358	30530423
17,80	TTD-3F04-1780-HP358	30596993
18,00	TTD-3F04-1800-HP358	30530424
18,10	TTD-3F04-1810-HP358	30596995
18,20	TTD-3F04-1820-HP358	30596996
18,30	TTD-3F04-1830-HP358	30596997
18,40	TTD-3F04-1840-HP358	30596998
18,50	TTD-3F04-1850-HP358	30530425
18,80	TTD-3F04-1880-HP358	30597000
18,90	TTD-3F04-1890-HP358	30597001
19,00	TTD-3F04-1900-HP358	30530427
19,20	TTD-3F04-1920-HP358	30597003
19,30	TTD-3F04-1930-HP358	30597004
19,50	TTD-3F04-1950-HP358	30530428
19,70	TTD-3F04-1970-HP358	30530429
19,80	TTD-3F04-1980-HP358	30597007
19,90	TTD-3F04-1990-HP358	30597008
20,00	TTD-3F04-2000-HP358	30530431
20,10	TTD-3F04-2010-HP358	30597009
20,20	TTD-3F04-2020-HP358	30597010
20,30	TTD-3F04-2030-HP358	30597011
20,40	TTD-3F04-2040-HP358	30597012
20,50	TTD-3F04-2050-HP358	30530432
20,60	TTD-3F04-2060-HP358	30597013
20,70	TTD-3F04-2070-HP358	30530433
21,00	TTD-3F04-2100-HP358	30530434
21,10	TTD-3F04-2110-HP358	30597016
21,20	TTD-3F04-2120-HP358	30597017
21,40	TTD-3F04-2140-HP358	30597019

Testina di foratura intercambiabile TTD in metallo duro integrale, adduzione interna del refrigerante - tipo 04

d ₁ da 21,50 a 26,10			d ₁ da 26,20 a 41,00		
d ₁ m7	Specifiche	Codice	d ₁ m7	Specifiche	Codice
21,50	TTD-3F04-2150-HP358	30530435	26,20	TTD-3F04-2620-HP358	30597052
21,70	TTD-3F04-2170-HP358	30530436	26,50	TTD-3F04-2650-HP358	30530450
21,80	TTD-3F04-2180-HP358	30597021	26,70	TTD-3F04-2670-HP358	30530451
22,00	TTD-3F04-2200-HP358	30530437	27,00	TTD-3F04-2700-HP358	30530452
22,10	TTD-3F04-2210-HP358	30597023	27,50	TTD-3F04-2750-HP358	30530453
22,20	TTD-3F04-2220-HP358	30597024	27,70	TTD-3F04-2770-HP358	30530454
22,30	TTD-3F04-2230-HP358	30597025	27,80	TTD-3F04-2780-HP358	30597063
22,40	TTD-3F04-2240-HP358	30597026	28,00	TTD-3F04-2800-HP358	30530455
22,50	TTD-3F04-2250-HP358	30530438	28,20	TTD-3F04-2820-HP358	30597066
22,60	TTD-3F04-2260-HP358	30597027	28,30	TTD-3F04-2830-HP358	30597067
22,70	TTD-3F04-2270-HP358	30530439	28,50	TTD-3F04-2850-HP358	30530456
23,00	TTD-3F04-2300-HP358	30530440	29,00	TTD-3F04-2900-HP358	30530458
23,10	TTD-3F04-2310-HP358	30597030	30,00	TTD-3F04-3000-HP358	30530461
23,30	TTD-3F04-2330-HP358	30597032	30,30	TTD-3F04-3030-HP358	30597082
23,50	TTD-3F04-2350-HP358	30530441	30,50	TTD-3F04-3050-HP358	30530462
23,70	TTD-3F04-2370-HP358	30530442	31,00	TTD-3F04-3100-HP358	30530464
24,00	TTD-3F04-2400-HP358	30530443	31,50	TTD-3F04-3150-HP358	30530465
24,40	TTD-3F04-2440-HP358	30597040	31,70	TTD-3F04-3170-HP358	30530466
24,50	TTD-3F04-2450-HP358	30530444	32,00	TTD-3F04-3200-HP358	30530467
24,70	TTD-3F04-2470-HP358	30530445	33,00	TTD-3F04-3300-HP358	30530469
24,80	TTD-3F04-2480-HP358	30597042	34,00	TTD-3F04-3400-HP358	30530471
25,00	TTD-3F04-2500-HP358	30530446	34,50	TTD-3F04-3450-HP358	30530472
25,20	TTD-3F04-2520-HP358	30597045	35,00	TTD-3F04-3500-HP358	30530473
25,30	TTD-3F04-2530-HP358	30597046	36,00	TTD-3F04-3600-HP358	30530475
25,40	TTD-3F04-2540-HP358	30597047	37,00	TTD-3F04-3700-HP358	30530477
25,50	TTD-3F04-2550-HP358	30530447	38,00	TTD-3F04-3800-HP358	30530479
25,90	TTD-3F04-2590-HP358	30597050	39,00	TTD-3F04-3900-HP358	30530481
26,00	TTD-3F04-2600-HP358	30530449	40,00	TTD-3F04-4000-HP358	30530483
26,10	TTD-3F04-2610-HP358	30597051	41,00	TTD-3F04-4100-HP358	30530485

Caratteristiche configurabili



Diametro:
Diametro a libera scelta a passi da
0,01 mm



Specifiche:

TTD-3F04-[diametro]-HP358

Dimensioni serie configurabile

d ₁ min.	d ₁ max.
12,00	45,00

Esempio:

TTD-3F04-1401-HP358

Diametro utensile d₁ = 14,01 mm

Misure in mm.

Per i parametri di lavorazione consigliati, vedere la fine del capitolo.

Versioni speciali e altri rivestimenti disponibili su richiesta.

Testina di foratura intercambiabile TTD

In metallo duro integrale, adduzione interna del refrigerante
Tipo 02 - Inox

Versione:

Diametro punta: 12,00 – 45,00 mm
Tolleranza di foratura: \geq IT 9
Materiale da taglio: HP385
Numero di taglienti: 2
Numero margini di guida: 3
Angolo tra taglienti: 138°

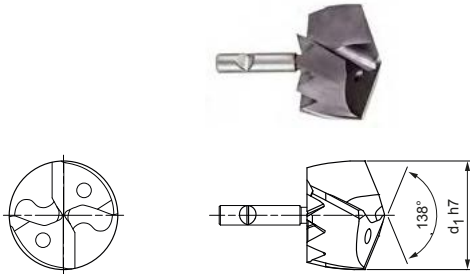

Serie selezionata per il magazzino

d ₁ da 12,00 a 16,40		
d ₁ h7	Specifiche	Codice
12,00	TTD-3F02-1200-HP385	30231780
12,10	TTD-3F02-1210-HP385	30248920
12,20	TTD-3F02-1220-HP385	30248921
12,40	TTD-3F02-1240-HP385	30248923
12,50	TTD-3F02-1250-HP385	30231784
12,60	TTD-3F02-1260-HP385	30248924
12,70	TTD-3F02-1270-HP385	30231787
13,00	TTD-3F02-1300-HP385	30231791
13,10	TTD-3F02-1310-HP385	30248927
13,50	TTD-3F02-1350-HP385	30231792
13,80	TTD-3F02-1380-HP385	30248932
14,00	TTD-3F02-1400-HP385	30231795
14,10	TTD-3F02-1410-HP385	30239446
14,20	TTD-3F02-1420-HP385	30248934
14,30	TTD-3F02-1430-HP385	30248935
14,40	TTD-3F02-1440-HP385	30248936
14,50	TTD-3F02-1450-HP385	30231802
14,60	TTD-3F02-1460-HP385	30248937
14,70	TTD-3F02-1470-HP385	30231804
14,80	TTD-3F02-1480-HP385	30248938
15,00	TTD-3F02-1500-HP385	30231805
15,10	TTD-3F02-1510-HP385	30248940
15,30	TTD-3F02-1530-HP385	30248942
15,50	TTD-3F02-1550-HP385	30231806
15,60	TTD-3F02-1560-HP385	30248944
15,70	TTD-3F02-1570-HP385	30219115
15,80	TTD-3F02-1580-HP385	30248945
15,90	TTD-3F02-1590-HP385	30248946
16,00	TTD-3F02-1600-HP385	30191427
16,10	TTD-3F02-1610-HP385	30248947
16,20	TTD-3F02-1620-HP385	30248948
16,30	TTD-3F02-1630-HP385	30248949
16,40	TTD-3F02-1640-HP385	30248950

d ₁ da 16,50 a 21,00		
d ₁ h7	Specifiche	Codice
16,50	TTD-3F02-1650-HP385	30191428
16,60	TTD-3F02-1660-HP385	30248951
16,70	TTD-3F02-1670-HP385	30219122
16,80	TTD-3F02-1680-HP385	30248952
17,00	TTD-3F02-1700-HP385	30191429
17,50	TTD-3F02-1750-HP385	30191430
17,60	TTD-3F02-1760-HP385	30248958
17,70	TTD-3F02-1770-HP385	30219123
17,80	TTD-3F02-1780-HP385	30248959
18,00	TTD-3F02-1800-HP385	30191431
18,20	TTD-3F02-1820-HP385	30248962
18,30	TTD-3F02-1830-HP385	30248963
18,50	TTD-3F02-1850-HP385	30191432
18,60	TTD-3F02-1860-HP385	30248965
18,80	TTD-3F02-1880-HP385	30248966
18,90	TTD-3F02-1890-HP385	30248967
19,00	TTD-3F02-1900-HP385	30191433
19,10	TTD-3F02-1910-HP385	30248968
19,20	TTD-3F02-1920-HP385	30248969
19,30	TTD-3F02-1930-HP385	30248970
19,40	TTD-3F02-1940-HP385	30248971
19,50	TTD-3F02-1950-HP385	30191434
19,70	TTD-3F02-1970-HP385	30219125
19,80	TTD-3F02-1980-HP385	30248973
19,90	TTD-3F02-1990-HP385	30248974
20,00	TTD-3F02-2000-HP385	30191435
20,10	TTD-3F02-2010-HP385	30248975
20,20	TTD-3F02-2020-HP385	30248976
20,30	TTD-3F02-2030-HP385	30248977
20,40	TTD-3F02-2040-HP385	30248978
20,50	TTD-3F02-2050-HP385	30191436
20,70	TTD-3F02-2070-HP385	30219126
21,00	TTD-3F02-2100-HP385	30191437

Testina di foratura intercambiabile TTD in metallo duro integrale, adduzione interna del refrigerante - tipo 02

d ₁ da 21,20 a 25,80		
d ₁ h7	Specifiche	Codice
21,20	TTD-3F02-2120-HP385	30248982
21,50	TTD-3F02-2150-HP385	30191438
21,70	TTD-3F02-2170-HP385	30219127
21,80	TTD-3F02-2180-HP385	30248986
22,00	TTD-3F02-2200-HP385	30191439
22,10	TTD-3F02-2210-HP385	30248988
22,40	TTD-3F02-2240-HP385	30248990
22,50	TTD-3F02-2250-HP385	30191440
22,60	TTD-3F02-2260-HP385	30248991
22,70	TTD-3F02-2270-HP385	30219128
22,80	TTD-3F02-2280-HP385	30248992
22,90	TTD-3F02-2290-HP385	30248993
23,00	TTD-3F02-2300-HP385	30191441
23,50	TTD-3F02-2350-HP385	30191442
23,70	TTD-3F02-2370-HP385	30219129
24,00	TTD-3F02-2400-HP385	30191443
24,20	TTD-3F02-2420-HP385	30249002
24,40	TTD-3F02-2440-HP385	30249004
24,50	TTD-3F02-2450-HP385	30191444
24,70	TTD-3F02-2470-HP385	30219130
24,80	TTD-3F02-2480-HP385	30249006
25,00	TTD-3F02-2500-HP385	30191445
25,20	TTD-3F02-2520-HP385	30249009
25,30	TTD-3F02-2530-HP385	30249010
25,40	TTD-3F02-2540-HP385	30249011
25,50	TTD-3F02-2550-HP385	30191446
25,70	TTD-3F02-2570-HP385	30219131
25,80	TTD-3F02-2580-HP385	30249013

d ₁ da 26,00 a 38,50		
d ₁ h7	Specifiche	Codice
26,00	TTD-3F02-2600-HP385	30191447
26,50	TTD-3F02-2650-HP385	30191448
26,80	TTD-3F02-2680-HP385	30249020
27,00	TTD-3F02-2700-HP385	30191449
27,10	TTD-3F02-2710-HP385	30249022
27,40	TTD-3F02-2740-HP385	30249025
27,50	TTD-3F02-2750-HP385	30191450
28,00	TTD-3F02-2800-HP385	30191451
28,10	TTD-3F02-2810-HP385	30249029
28,20	TTD-3F02-2820-HP385	30249030
28,50	TTD-3F02-2850-HP385	30191452
28,60	TTD-3F02-2860-HP385	30249033
28,70	TTD-3F02-2870-HP385	30219134
29,00	TTD-3F02-2900-HP385	30191453
29,50	TTD-3F02-2950-HP385	30191454
29,70	TTD-3F02-2970-HP385	30219135
29,80	TTD-3F02-2980-HP385	30249041
29,90	TTD-3F02-2990-HP385	30249042
30,00	TTD-3F02-3000-HP385	30191455
30,10	TTD-3F02-3010-HP385	30249043
30,30	TTD-3F02-3030-HP385	30249045
31,00	TTD-3F02-3100-HP385	30191457
31,30	TTD-3F02-3130-HP385	30249052
31,50	TTD-3F02-3150-HP385	30191458
31,80	TTD-3F02-3180-HP385	30249055
32,00	TTD-3F02-3200-HP385	30191459
38,50	TTD-3F02-3850-HP385	30322384

Caratteristiche configurabili



Diametro:
Diametro a libera scelta a passi da 0,01 mm



Specifiche:
TTD-3F02-[diametro]-HP358

Dimensioni serie configurabile

d ₁ min.	d ₁ max.
12,00	45,00

Esempio:
TTD-3F02-1401-HP358

Diametro utensile d₁ = 14,01 mm

Misure in mm.

Per i parametri di lavorazione consigliati, vedere la fine del capitolo.

Versioni speciali e altri rivestimenti disponibili su richiesta.

Testina di foratura intercambiabile TTD

In metallo duro integrale, adduzione interna del refrigerante
Tipo 05 - Iron

Versione:

Diametro punta: 12,00 – 45,00 mm
Tolleranza di foratura: \geq IT 9
Materiale da taglio: HP240
Numero di taglienti: 2
Numero margini di guida: 4
Angolo tra taglienti: 140°

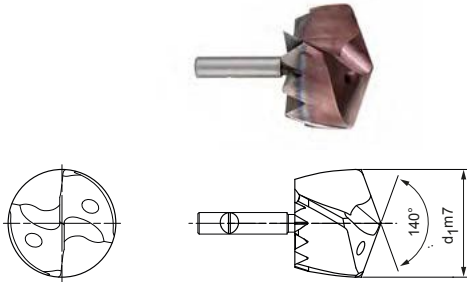

Serie selezionata per il magazzino

d ₁ da 12,50 a 20,80		
d ₁ m7	Specifiche	Codice
12,50	TTD-4F05-1250-HP240	30597144
12,70	TTD-4F05-1270-HP240	30597146
14,00	TTD-4F05-1400-HP240	30597159
14,50	TTD-4F05-1450-HP240	30597164
15,30	TTD-4F05-1530-HP240	30597173
15,70	TTD-4F05-1570-HP240	30597177
16,30	TTD-4F05-1630-HP240	30597183
16,50	TTD-4F05-1650-HP240	30597185
16,70	TTD-4F05-1670-HP240	30597187
16,80	TTD-4F05-1680-HP240	30597188
17,00	TTD-4F05-1700-HP240	30597190
17,10	TTD-4F05-1710-HP240	30597191
17,50	TTD-4F05-1750-HP240	30597195
18,00	TTD-4F05-1800-HP240	30597200
18,20	TTD-4F05-1820-HP240	30597202
18,50	TTD-4F05-1850-HP240	30597205
18,60	TTD-4F05-1860-HP240	30597206
18,80	TTD-4F05-1880-HP240	30597208
19,00	TTD-4F05-1900-HP240	30597210
19,70	TTD-4F05-1970-HP240	30597217
20,50	TTD-4F05-2050-HP240	30597225
20,70	TTD-4F05-2070-HP240	30597227
20,80	TTD-4F05-2080-HP240	30597228

d ₁ da 21,00 a 37,00		
d ₁ m7	Specifiche	Codice
21,00	TTD-4F05-2100-HP240	30597230
21,10	TTD-4F05-2110-HP240	30597231
21,50	TTD-4F05-2150-HP240	30597235
21,70	TTD-4F05-2170-HP240	30597237
22,00	TTD-4F05-2200-HP240	30597240
22,10	TTD-4F05-2210-HP240	30597241
22,30	TTD-4F05-2230-HP240	30597243
22,70	TTD-4F05-2270-HP240	30597247
23,00	TTD-4F05-2300-HP240	30597250
23,50	TTD-4F05-2350-HP240	30597255
24,00	TTD-4F05-2400-HP240	30597260
24,40	TTD-4F05-2440-HP240	30597264
24,80	TTD-4F05-2480-HP240	30597268
25,00	TTD-4F05-2500-HP240	30597270
25,80	TTD-4F05-2580-HP240	30597278
26,00	TTD-4F05-2600-HP240	30597280
27,00	TTD-4F05-2700-HP240	30597290
27,10	TTD-4F05-2710-HP240	30597291
28,00	TTD-4F05-2800-HP240	30597300
28,50	TTD-4F05-2850-HP240	30597305
30,00	TTD-4F05-3000-HP240	30597320
32,00	TTD-4F05-3200-HP240	30597341
37,00	TTD-4F05-3700-HP240	30597351

Caratteristiche configurabili



Diametro:

Diametro a libera scelta a passi da 0,01 mm



Specifiche:

TTD-4F05-[diametro]-HP240

Dimensioni serie configurabile

d ₁ min.	d ₁ max.
12,00	45,00

Esempio:

TTD-4F05-1401-HP619

Diametro utensile d₁ = 14,01 mm

Misure in mm.

Per i parametri di lavorazione consigliati, vedere la fine del capitolo.

Versioni speciali e altri rivestimenti disponibili su richiesta.

Testina di foratura intercambiabile TTD

In metallo duro integrale, adduzione interna del refrigerante
Tipo 03 - Alu

Versione:

Diametro punta: 12,00 – 45,00 mm
Tolleranza di foratura: \geq IT 9
Materiale da taglio: HP685
Numero di taglienti: 2
Numero margini di guida: 4
Angolo tra taglienti: 140°

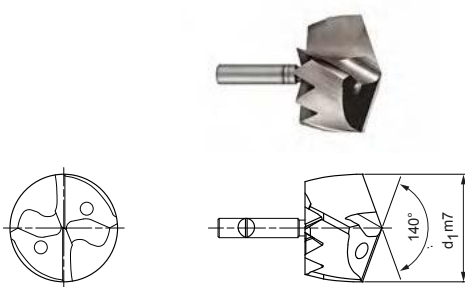

Serie selezionata per il magazzino

d ₁ da 12,10 a 21,00		
d ₁ m7	Specifiche	Codice
12,10	TTD-4F03-1210-HP685	30249057
12,50	TTD-4F03-1250-HP685	30231808
12,80	TTD-4F03-1280-HP685	30249062
13,00	TTD-4F03-1300-HP685	30231812
13,50	TTD-4F03-1350-HP685	30231815
14,00	TTD-4F03-1400-HP685	30231817
14,50	TTD-4F03-1450-HP685	30231818
14,70	TTD-4F03-1470-HP685	30231819
14,90	TTD-4F03-1490-HP685	30249077
15,00	TTD-4F03-1500-HP685	30231820
16,00	TTD-4F03-1600-HP685	30191460
16,10	TTD-4F03-1610-HP685	30249085
16,50	TTD-4F03-1650-HP685	30191461
17,00	TTD-4F03-1700-HP685	30191462
17,50	TTD-4F03-1750-HP685	30191463
18,00	TTD-4F03-1800-HP685	30191464
18,10	TTD-4F03-1810-HP685	30234210
18,20	TTD-4F03-1820-HP685	30249099
18,30	TTD-4F03-1830-HP685	30249100
18,50	TTD-4F03-1850-HP685	30191465
18,60	TTD-4F03-1860-HP685	30249102
18,70	TTD-4F03-1870-HP685	30219141
19,00	TTD-4F03-1900-HP685	30191466
19,50	TTD-4F03-1950-HP685	30191467
19,60	TTD-4F03-1960-HP685	30249109
20,00	TTD-4F03-2000-HP685	30191468
20,30	TTD-4F03-2030-HP685	30216431
20,50	TTD-4F03-2050-HP685	30191469
21,00	TTD-4F03-2100-HP685	30191470

d ₁ da 21,50 a 43,00		
d ₁ m7	Specifiche	Codice
21,50	TTD-4F03-2150-HP685	30191471
22,00	TTD-4F03-2200-HP685	30191472
22,50	TTD-4F03-2250-HP685	30191473
22,60	TTD-4F03-2260-HP685	30249129
23,00	TTD-4F03-2300-HP685	30191474
23,50	TTD-4F03-2350-HP685	30191475
23,90	TTD-4F03-2390-HP685	30249138
24,00	TTD-4F03-2400-HP685	30191476
24,10	TTD-4F03-2410-HP685	30249139
24,40	TTD-4F03-2440-HP685	30249142
24,50	TTD-4F03-2450-HP685	30191477
25,00	TTD-4F03-2500-HP685	30191478
25,10	TTD-4F03-2510-HP685	30249146
25,20	TTD-4F03-2520-HP685	30249147
25,50	TTD-4F03-2550-HP685	30191479
26,00	TTD-4F03-2600-HP685	30191480
26,40	TTD-4F03-2640-HP685	30249156
27,00	TTD-4F03-2700-HP685	30191482
27,50	TTD-4F03-2750-HP685	30191483
28,00	TTD-4F03-2800-HP685	30191484
28,30	TTD-4F03-2830-HP685	30249169
28,40	TTD-4F03-2840-HP685	30249170
29,50	TTD-4F03-2950-HP685	30191487
31,00	TTD-4F03-3100-HP685	30191490
31,20	TTD-4F03-3120-HP685	30249189
32,00	TTD-4F03-3200-HP685	30191492
35,00	TTD-4F03-3500-HP685	30322405
43,00	TTD-4F03-4300-HP685	30322423

Caratteristiche configurabili



Diametro:

Diametro a libera scelta a passi da 0,01 mm



Specifiche:

TTD-4F03-[diametro]-HP685

Dimensioni serie configurabile

d ₁ min.	d ₁ max.
12.00	45.00

Esempio:

TTD-4F03-1401-HP685

Diametro utensile d₁ = 14,01 mm

Misure in mm.

Per i parametri di lavorazione consigliati, vedere la fine del capitolo.

Versioni speciali e altri rivestimenti disponibili su richiesta.

Supporto per testina intercambiabile TTS

Con sistema a serraggio frontale per punte ad inserto intercambiabile TTD
TTS100, adduzione interna del refrigerante

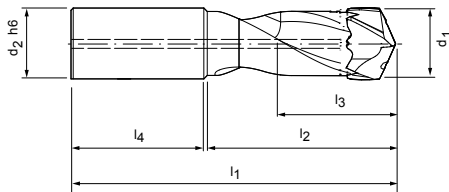

Versione:

Per diametro punta:

12,00 - 45,49 mm

Sistema di cambio:

Sistema a serraggio frontale

Possibilità di sostituzione della testina direttamente sulla macchina

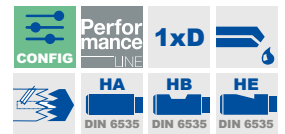

Serie selezionata per il magazzino

Dimensioni							Forma del codolo HB	
d ₁	Attacco	d ₂ h6	l ₁	l ₂	l ₃	l ₄	Specifiche	Codice
12,00-12,49	TTS12-S	14	81	29	13	45	TTS100-12-DR1-1200-14-HB	30324304
12,50-12,99	TTS12-S	14	81	29	13	45	TTS100-12-DR1-1250-14-HB	30324305
13,00-13,49	TTS12-S	14	81	31	14	45	TTS100-12-DR1-1300-14-HB	30324306
13,50-13,99	TTS12-S	16	86	32	14	48	TTS100-12-DR1-1350-16-HB	30324307
14,00-14,49	TTS12-S	16	86	33	15	48	TTS100-12-DR1-1400-16-HB	30324308
14,50-14,99	TTS12-S	16	91	34	15	48	TTS100-12-DR1-1450-16-HB	30324309
15,00-15,49	TTS12-S	16	91	36	16	48	TTS100-12-DR1-1500-16-HB	30324310
15,50-16,49	TTS12-S	18	92	38	17	48	TTS100-12-DR1-1550-18-HB	30324311
16,50-17,49	TTS12-S	18	94	40	18	48	TTS100-12-DR1-1650-18-HB	30324312
17,50-18,49	TTS12-S	18	99	43	19	48	TTS100-12-DR1-1750-18-HB	30324313
18,50-19,49	TTS12-S	20	99	45	20	50	TTS100-12-DR1-1850-20-HB	30324314
19,50-20,49	TTS12-S	20	104	47	21	50	TTS100-12-DR1-1950-20-HB	30324316
20,50-21,49	TTS12-S	25	111	49	22	56	TTS100-12-DR1-2050-25-HB	30324317
21,50-22,49	TTS12-S	25	116	52	23	56	TTS100-12-DR1-2150-25-HB	30324318
22,50-23,49	TTS12-S	25	116	54	24	56	TTS100-12-DR1-2250-25-HB	30324319
23,50-24,49	TTS12-S	25	121	56	25	56	TTS100-12-DR1-2350-25-HB	30324320
24,50-25,49	TTS18-S	25	123	59	26	56	TTS100-18-DR1-2450-25-HB	30324321
25,50-26,49	TTS18-S	25	123	61	27	56	TTS100-18-DR1-2550-25-HB	30324322
26,50-27,49	TTS18-S	25	128	63	28	56	TTS100-18-DR1-2650-25-HB	30324323
27,50-28,49	TTS18-S	25	128	66	29	56	TTS100-18-DR1-2750-25-HB	30324325
28,50-29,49	TTS18-S	32	134	68	30	60	TTS100-18-DR1-2850-32-HB	30324327
29,50-30,49	TTS18-S	32	139	70	31	60	TTS100-18-DR1-2950-32-HB	30324328
30,50-31,49	TTS18-S	32	139	75	32	60	TTS100-18-DR1-3050-32-HB	30324329
31,50-32,49	TTS18-S	32	139	75	33	60	TTS100-18-DR1-3150-32-HB	30324330
32,50-33,49	TTS18-S	32	150	78	34	60	TTS100-18-DR1-3250-32-HB	30374587
33,50-34,49	TTS18-S	32	150	79	35	60	TTS100-18-DR1-3350-32-HB	30374590
34,50-35,49	TTS12-S	32	152	86	36	60	TTS100-18-DR1-3550-32-HB	30496703
34,50-35,49	TTS18-S	32	150	82	36	60	TTS100-18-DR1-3450-32-HB	30374593
35,50-37,49	TTS18-S	40	162	86	38	70	TTS100-18-DR1-3550-40-HB	30535302
37,50-39,49	TTS18-S	32	157	91	40	60	TTS100-18-DR1-3750-32-HB	30496704
37,50-39,49	TTS18-S	40	167	71	40	70	TTS100-18-DR1-3750-40-HB	30535303

Prosegue alla pagina seguente.

Supporto per testina intercambiabile TTS 100, adduzione interna del refrigerante

Dimensioni							Forma del codolo HB	
d ₁	Attacco	d ₂ h6	l ₁	l ₂	l ₃	l ₄	Specifiche	Codice
39,50-41,49	TTS18-S	32	167	95	42	60	TTS100-18-DR1-3950-32-HB	30496705
39,50-41,49	TTS18-S	40	177	95	42	70	TTS100-18-DR1-3950-40-HB	30535305
41,50-43,49	TTS18-S	40	180	100	44	70	TTS100-18-DR1-4150-40-HB	30535307
43,50-45,49	TTS18-S	40	185	105	46	70	TTS100-18-DR1-4350-40-HB	30535312

Caratteristiche configurabili



Forma del codolo:
Forma del codolo: HA | HE



Specifiche:
TTS100-18-DR1-4150-40-[forma del codolo]

Esempio:

TTS100-18-DR1-4150-40-HE

Forma del codolo HE

Supporto per testina intercambiabile TTS

Con sistema a serraggio frontale per punta ad inserto intercambiabile TTD
TTS100 (3xD), adduzione interna del refrigerante

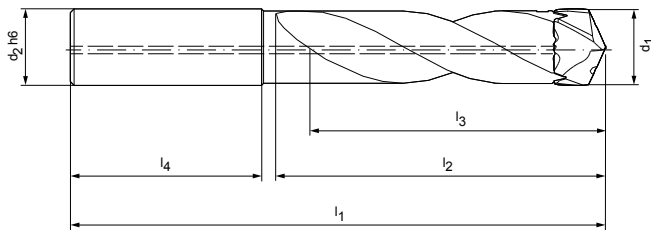

Versione:

Per diametro punta:

12,00 - 45,49 mm

Sistema di cambio:

Sistema a serraggio frontale

Possibilità di sostituzione della testina direttamente sulla macchina

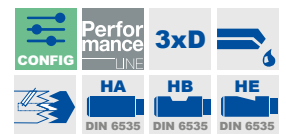

Serie selezionata per il magazzino

Dimensioni							Forma del codolo HB	
d ₁	Attacco	d ₂ h6	l ₁	l ₂	l ₃	l ₄	Specifiche	Codice
12,00-12,49	TTS12-S	14	100	53	38	45	TTS100-12-DR3-1200-14-HB	30232785
12,50-12,99	TTS12-S	14	105	55	39	45	TTS100-12-DR3-1250-14-HB	30232787
13,00-13,49	TTS12-S	14	105	57	41	45	TTS100-12-DR3-1300-14-HB	30232789
13,50-13,99	TTS12-S	16	110	59	42	48	TTS100-12-DR3-1350-16-HB	30232790
14,00-14,49	TTS12-S	16	115	61	44	48	TTS100-12-DR3-1400-16-HB	30232792
14,50-14,99	TTS12-S	16	115	63	45	48	TTS100-12-DR3-1450-16-HB	30232793
15,00-15,49	TTS12-S	16	115	65	47	48	TTS100-12-DR3-1500-16-HB	30232794
15,50-16,49	TTS12-S	18	120	70	50	48	TTS100-12-DR3-1550-18-HB	30191496
16,50-17,49	TTS12-S	18	125	74	53	48	TTS100-12-DR3-1650-18-HB	30191497
17,50-18,49	TTS12-S	18	130	78	56	48	TTS100-12-DR3-1750-18-HB	30191498
18,50-19,49	TTS12-S	20	135	82	59	50	TTS100-12-DR3-1850-20-HB	30191499
19,50-20,49	TTS12-S	20	140	87	62	50	TTS100-12-DR3-1950-20-HB	30191500
20,50-21,49	TTS12-S	25	150	91	65	56	TTS100-12-DR3-2050-25-HB	30191501
21,50-22,49	TTS12-S	25	155	95	68	56	TTS100-12-DR3-2150-25-HB	30191502
22,50-23,49	TTS12-S	25	160	99	71	56	TTS100-12-DR3-2250-25-HB	30191503
23,50-24,49	TTS12-S	25	165	103	74	56	TTS100-12-DR3-2350-25-HB	30191504
24,50-25,49	TTS18-S	25	165	108	77	56	TTS100-18-DR3-2450-25-HB	30191505
25,50-26,49	TTS18-S	25	175	112	80	56	TTS100-18-DR3-2550-25-HB	30191507
26,50-27,49	TTS18-S	25	175	116	83	56	TTS100-18-DR3-2650-25-HB	30191508
27,50-28,49	TTS18-S	25	180	120	86	56	TTS100-18-DR3-2750-25-HB	30191509
28,50-29,49	TTS18-S	32	190	124	89	60	TTS100-18-DR3-2850-32-HB	30191510
29,50-30,49	TTS18-S	32	195	129	92	60	TTS100-18-DR3-2950-32-HB	30191511
30,50-31,49	TTS18-S	32	195	133	95	60	TTS100-18-DR3-3050-32-HB	30191512
31,50-32,49	TTS18-S	32	200	137	98	60	TTS100-18-DR3-3150-32-HB	30191513
32,50-33,49	TTS18-S	32	210	144	101	60	TTS100-18-DR3-3250-32-HB	30322289
33,50-34,49	TTS18-S	32	215	148	104	60	TTS100-18-DR3-3350-32-HB	30322290
34,50-35,49	TTS18-S	32	227	161	107	60	TTS100-18-DR3-3550-32-HB	30496706
34,50-35,49	TTS18-S	32	220	153	107	60	TTS100-18-DR3-3450-32-HB	30322291
35,50-37,49	TTS18-S	40	237	161	113	70	TTS100-18-DR3-3550-40-HB	30535313
37,50-39,49	TTS18-S	32	237	170	119	60	TTS100-18-DR3-3750-32-HB	30496707
37,50-39,49	TTS18-S	40	247	170	119	70	TTS100-18-DR3-3750-40-HB	30535316
39,50-41,49	TTS18-S	32	247	178	125	60	TTS100-18-DR3-3950-32-HB	30496708

Prosegue alla pagina seguente.

Supporto per testina intercambiabile TTS 100 (3xD), adduzione interna del refrigerante

Dimensioni							Forma del codolo HB	
d ₁	Attacco	d ₂ h6	l ₁	l ₂	l ₃	l ₄	Specifiche	Codice
39,50-41,49	TTS18-S	40	257	178	125	70	TTS100-18-DR3-3950-40-HB	30535318
41,50-43,49	TTS18-S	40	265	187	131	70	TTS100-18-DR3-4150-40-HB	30535320
43,50-45,49	TTS18-S	40	275	196	137	70	TTS100-18-DR3-4350-40-HB	30535321

Caratteristiche configurabili



Forma del codolo:
Forma del codolo: HA | HE



Specifiche:
TTS100-18-DR5-4150-40-[forma del codolo]

Esempio:

TTS100-18-DR5-4150-40-HE

Forma del codolo HE

Supporto per testina intercambiabile TTS

Con sistema a serraggio frontale per punta ad inserto intercambiabile TTD
TTS100 (5xD), adduzione interna del refrigerante

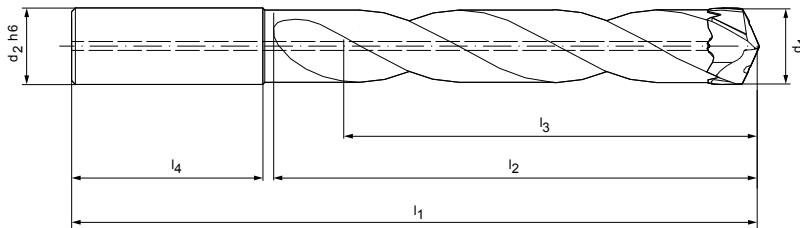

Versione:

Per diametro punta:

12,00 - 45,49 mm

Sistema di cambio:

Sistema a serraggio frontale

Possibilità di sostituzione della testina direttamente sulla macchina

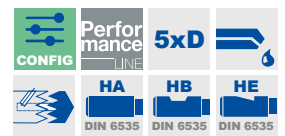

Serie selezionata per il magazzino

Dimensioni							Forma del codolo HB	
d ₁	Attacco	d ₂ h6	l ₁	l ₂	l ₃	l ₄	Specifiche	Codice
12,00-12,49	TTS12-S	14	125	78	63	45	TTS100-12-DR5-1200-14-HB	30232796
12,50-12,99	TTS12-S	14	130	81	65	45	TTS100-12-DR5-1250-14-HB	30232798
13,00-13,49	TTS12-S	14	130	84	68	45	TTS100-12-DR5-1300-14-HB	30232799
13,50-13,99	TTS12-S	16	140	88	70	48	TTS100-12-DR5-1350-16-HB	30232800
14,00-14,49	TTS12-S	16	140	90	73	48	TTS100-12-DR5-1400-16-HB	30232801
14,50-14,99	TTS12-S	16	145	94	75	48	TTS100-12-DR5-1450-16-HB	30232802
15,00-15,49	TTS12-S	16	145	96	78	48	TTS100-12-DR5-1500-16-HB	30232803
15,50-16,49	TTS12-S	18	155	103	83	48	TTS100-12-DR5-1550-18-HB	30191514
16,50-17,49	TTS12-S	18	160	109	88	48	TTS100-12-DR5-1650-18-HB	30191515
17,50-18,49	TTS12-S	18	165	115	93	48	TTS100-12-DR5-1750-18-HB	30191516
18,50-19,49	TTS12-S	20	175	121	98	50	TTS100-12-DR5-1850-20-HB	30191517
19,50-20,49	TTS12-S	20	180	128	103	50	TTS100-12-DR5-1950-20-HB	30191518
20,50-21,49	TTS12-S	25	195	134	108	56	TTS100-12-DR5-2050-25-HB	30191519
21,50-22,49	TTS12-S	25	200	140	113	56	TTS100-12-DR5-2150-25-HB	30191520
22,50-23,49	TTS12-S	25	205	146	118	56	TTS100-12-DR5-2250-25-HB	30191521
23,50-24,49	TTS12-S	25	210	152	123	56	TTS100-12-DR5-2350-25-HB	30191522
24,50-25,49	TTS18-S	25	220	159	128	56	TTS100-18-DR5-2450-25-HB	30191523
25,50-26,49	TTS18-S	25	225	165	133	56	TTS100-18-DR5-2550-25-HB	30191525
26,50-27,49	TTS18-S	25	230	171	138	56	TTS100-18-DR5-2650-25-HB	30191526
27,50-28,49	TTS18-S	25	240	177	143	56	TTS100-18-DR5-2750-25-HB	30191527
28,50-29,49	TTS18-S	32	250	183	148	60	TTS100-18-DR5-2850-32-HB	30191528
29,50-30,49	TTS18-S	32	255	190	153	60	TTS100-18-DR5-2950-32-HB	30191529
30,50-31,49	TTS18-S	32	260	196	158	60	TTS100-18-DR5-3050-32-HB	30191530
31,50-32,49	TTS18-S	32	265	202	163	60	TTS100-18-DR5-3150-32-HB	30191531
32,50-33,49	TTS18-S	32	275	210	168	60	TTS100-18-DR5-3250-32-HB	30322313
33,50-34,49	TTS18-S	32	285	217	173	60	TTS100-18-DR5-3350-32-HB	30322314
34,50-35,49	TTS18-S	32	290	224	178	60	TTS100-18-DR5-3450-32-HB	30322315
35,50-37,49	TTS18-S	32	302	236	188	60	TTS100-18-DR5-3550-32-HB	30496709
*35,50-37,49	TTS18-S	40	312	236	188	70	TTS100-18-DR5-3550-40-HB	30535324
37,50-39,49	TTS18-S	32	317	249	198	60	TTS100-18-DR5-3750-32-HB	30496710
*37,50-39,49	TTS18-S	40	327	249	198	70	TTS100-18-DR5-3750-40-HB	30534860

Prosegue alla pagina seguente.

Supporto per testina intercambiabile TTS 100 (5xD), adduzione interna del refrigerante

Dimensioni							Forma del codolo HB	
d ₁	Attacco	d ₂ h6	l ₁	l ₂	l ₃	l ₄	Specifiche	Codice
39,50-41,49	TTS18-S	32	327	261	208	60	TTS100-18-DR5-3950-32-HB	30496711
*39,50-41,49	TTS18-S	40	337	261	208	70	TTS100-18-DR5-3950-40-HB	30535326
*41,50-43,49	TTS18-S	40	350	274	218	70	TTS100-18-DR5-4150-40-HB	30535327
*43,50-45,49	TTS18-S	40	365	287	228	70	TTS100-18-DR5-4350-40-HB	30535328

Caratteristiche configurabili



Forma del codolo:
Forma del codolo: HA | HE



Specifiche:
TTS100-18-DR5-4150-40-[forma del codolo]

Esempio:

TTS100-18-DR5-4150-40-HE

Forma del codolo HE

Supporto per testina intercambiabile TTS

Con sistema a serraggio frontale per punta ad inserto intercambiabile TTD
TTS100 (8xD), adduzione interna del refrigerante

Versione:

Per diametro punta:
Sistema di cambio:

12,00 - 45,49 mm
Sistema a serraggio frontale
Possibilità di sostituzione della testina direttamente sulla macchina

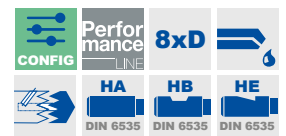
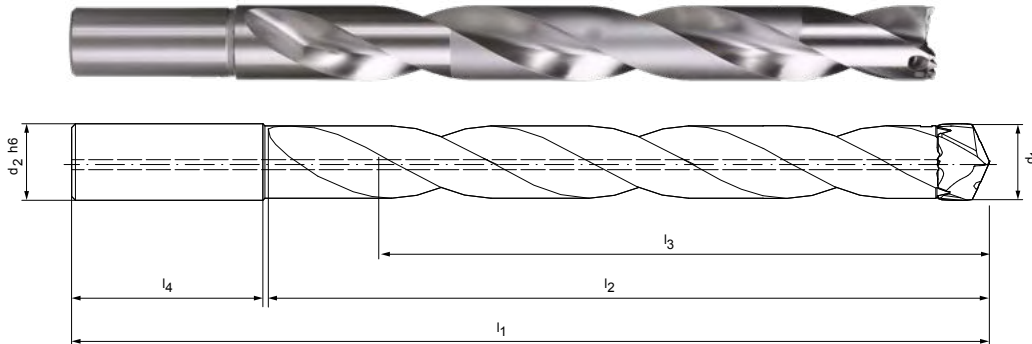

Serie selezionata per il magazzino

Dimensioni							Forma del codolo HB	
d_1	Attacco	d_2 h6	l_1	l_2	l_3	l_4	Specifiche	Codice
12,00-12,49	TTS12-S	14	165	116	100	45	TTS100-12-DR8-1200-14-HB	30232805
12,50-12,99	TTS12-S	14	170	121	104	45	TTS100-12-DR8-1250-14-HB	30232806
13,00-13,49	TTS12-S	14	175	126	108	45	TTS100-12-DR8-1300-14-HB	30232807
13,50-13,99	TTS12-S	16	180	129	112	48	TTS100-12-DR8-1350-16-HB	30232808
14,00-14,49	TTS12-S	16	185	134	116	48	TTS100-12-DR8-1400-16-HB	30232809
14,50-14,99	TTS12-S	16	190	139	120	48	TTS100-12-DR8-1450-16-HB	30232810
15,00-15,49	TTS12-S	16	195	144	124	48	TTS100-12-DR8-1500-16-HB	30232811
15,50-16,49	TTS12-S	18	205	152	132	48	TTS100-12-DR8-1550-18-HB	30191532
16,50-17,49	TTS12-S	18	215	161	140	48	TTS100-12-DR8-1650-18-HB	30191533
17,50-18,49	TTS12-S	18	220	171	148	48	TTS100-12-DR8-1750-18-HB	30191534
18,50-19,49	TTS12-S	20	235	180	156	50	TTS100-12-DR8-1850-20-HB	30191535
19,50-20,49	TTS12-S	20	240	189	164	50	TTS100-12-DR8-1950-20-HB	30191536
20,50-21,49	TTS12-S	25	260	198	172	56	TTS100-12-DR8-2050-25-HB	30191537
21,50-22,49	TTS12-S	25	270	207	180	56	TTS100-12-DR8-2150-25-HB	30191538
22,50-23,49	TTS12-S	25	275	217	188	56	TTS100-12-DR8-2250-25-HB	30191539
23,50-24,49	TTS12-S	25	285	226	196	56	TTS100-12-DR8-2350-25-HB	30191540
24,50-25,49	TTS18-S	25	295	235	204	56	TTS100-18-DR8-2450-25-HB	30191541
25,50-26,49	TTS18-S	25	305	244	212	56	TTS100-18-DR8-2550-25-HB	30191543
26,50-27,49	TTS18-S	25	315	253	220	56	TTS100-18-DR8-2650-25-HB	30191544
27,50-28,49	TTS18-S	25	325	263	228	56	TTS100-18-DR8-2750-25-HB	30191545
28,50-29,49	TTS18-S	32	340	272	236	60	TTS100-18-DR8-2850-32-HB	30191546
29,50-30,49	TTS18-S	32	345	281	244	60	TTS100-18-DR8-2950-32-HB	30191547
30,50-31,49	TTS18-S	32	355	290	252	60	TTS100-18-DR8-3050-32-HB	30191548
31,50-32,49	TTS18-S	32	360	299	260	60	TTS100-18-DR8-3150-32-HB	30191549
32,50 - 33,49	TTS18-S	32	375	275	268	60	TTS100-18-DR8-3250-32-HB	30809129
33,50 - 34,49	TTS18-S	32	385	317	276	60	TTS100-18-DR8-3350-32-HB	30809654
34,50 - 35,49	TTS18-S	32	395	329	284	60	TTS100-18-DR8-3450-32-HB	30809664
35,50 - 37,49	TTS18-S	32	402	336	300	60	TTS100-18-DR8-3550-32-HB	30812380
35,50 - 37,49	TTS18-S	40	412	336	300	70	TTS100-18-DR8-3550-40-HB	30809673

Prosegue alla pagina seguente.

Supporto per testina intercambiabile TTS 100 (8xD), adduzione interna del refrigerante

Dimensioni							Forma del codolo HB	
d ₁	Attacco	d ₂ h6	l ₁	l ₂	l ₃	l ₄	Specifiche	Codice
37,50 - 39,49	TTS18-S	32	421	353	316	60	TTS100-18-DR8-3750-32-HB	30812379
37,50 - 39,49	TTS18-S	40	431	353	316	70	TTS100-18-DR8-3750-40-HB	30809961
39,50 - 41,49	TTS18-S	32	440	374	332	70	TTS100-18-DR8-3950-32-HB	30812376
39,50 - 41,49	TTS18-S	40	450	374	332	70	TTS100-18-DR8-3950-40-HB	30809964
41,50 - 43,49	TTS18-S	40	470	394	348	70	TTS100-18-DR8-4150-40-HB	30809976
43,50 - 45,49	TTS18-S	40	500	422	364	70	TTS100-18-DR8-4350-40-HB	30809158

Caratteristiche configurabili



Forma del codolo:
Forma del codolo: HA | HE



Specifiche:
TTS100-18-DR8-4150-40-[forma del codolo]

Esempio:

TTS100-18-DR8-4150-40-HE

Forma del codolo HE

Supporto per testina intercambiabile TTS

Con sistema a serraggio frontale per punta ad inserto intercambiabile TTD
TTS100 (12xD), adduzione interna del refrigerante

Versione:

Per diametro punta:

12,00 - 32,49 mm

Sistema di cambio:

Sistema a serraggio frontale

Possibilità di sostituzione della testina direttamente sulla macchina

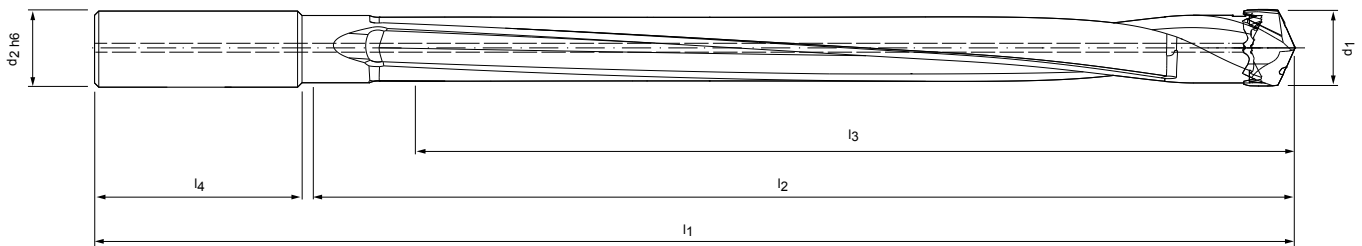

Serie selezionata per il magazzino

Dimensioni							Forma del codolo HB	
d ₁	Attacco	d ₂ h6	l ₁	l ₂	l ₃	l ₄	Specifiche	Codice
12,00-12,49	TTS12-S	14	210	162	150	45	TTS100-12-DR12-1200-14-HB	30327798
12,50-12,99	TTS12-S	14	216	168	156	45	TTS100-12-DR12-1250-14-HB	30327802
13,00-13,49	TTS12-S	14	223	175	162	45	TTS100-12-DR12-1300-14-HB	30327805
13,50-13,99	TTS12-S	16	235	182	168	48	TTS100-12-DR12-1350-16-HB	30327808
14,00-14,49	TTS12-S	16	242	189	174	48	TTS100-12-DR12-1400-16-HB	30327811
14,50-14,99	TTS12-S	16	248	195	180	48	TTS100-12-DR12-1450-16-HB	30327814
15,00-15,49	TTS12-S	16	255	202	186	48	TTS100-12-DR12-1500-16-HB	30327817
15,50-16,49	TTS12-S	18	262	209	198	48	TTS100-12-DR12-1550-18-HB	30327820
16,50-17,49	TTS12-S	18	275	222	210	48	TTS100-12-DR12-1650-18-HB	30327824
17,50-18,49	TTS12-S	18	289	236	222	48	TTS100-12-DR12-1750-18-HB	30327828
18,50-19,49	TTS12-S	20	304	249	234	50	TTS100-12-DR12-1850-20-HB	30327833
19,50-20,49	TTS12-S	20	318	263	246	50	TTS100-12-DR12-1950-20-HB	30255588
20,50-21,49	TTS12-S	25	337	276	258	56	TTS100-12-DR12-2050-25-HB	30327844
21,50-22,49	TTS12-S	25	351	290	270	56	TTS100-12-DR12-2150-25-HB	30327847
22,50-23,49	TTS12-S	25	364	303	282	56	TTS100-12-DR12-2250-25-HB	30327851
23,50-24,49	TTS12-S	25	378	317	294	56	TTS100-12-DR12-2350-25-HB	30327854
24,50-25,49	TTS18-S	25	391	330	306	56	TTS100-18-DR12-2450-25-HB	30327859
25,50-26,49	TTS18-S	25	405	344	318	56	TTS100-18-DR12-2550-25-HB	30327863
26,50-27,49	TTS18-S	25	418	357	330	56	TTS100-18-DR12-2650-25-HB	30327866
27,50-28,49	TTS18-S	25	432	371	342	56	TTS100-18-DR12-2750-25-HB	30327870
28,50-29,49	TTS18-S	32	449	384	354	60	TTS100-18-DR12-2850-32-HB	30327873
29,50-30,49	TTS18-S	32	463	398	366	60	TTS100-18-DR12-2950-32-HB	30327876
30,50-31,49	TTS18-S	32	476	411	378	60	TTS100-18-DR12-3050-32-HB	30327879
31,50-32,49	TTS18-S	32	490	425	390	60	TTS100-18-DR12-3150-32-HB	30327883

Caratteristiche configurabili



Forma del codolo:
Forma del codolo: HA | HE



Specifiche:

TTS100-18-DR12-2850-32-[forma del codolo]

Esempio:

TTS100-18-DR12-2850-32-HE

Forma del codolo HE

Misure in mm.

Osservare le indicazioni per l'utilizzo della punta ad inserto intercambiabile TTD (12xD) riportate a pagina 748. Versioni speciali disponibili su richiesta.

Parti di ricambio

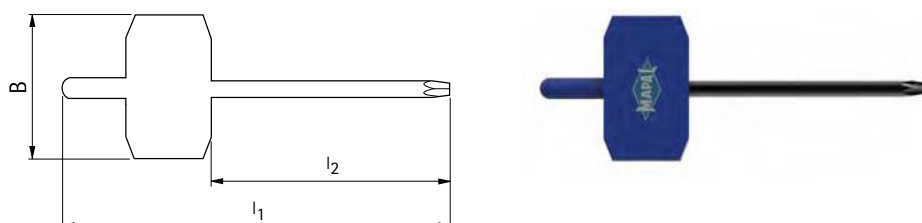

Cacciavite esagonale

Tipo di supporto	sw	l ₁	l ₂	B	Codice
TS100-12-DRx-1200-14-HB	1,3	95	60	38	10004355
TS100-12-DRx-1250-14-HB	1,3	95	60	38	10004355
TS100-12-DRx-1300-14-HB	1,3	95	60	38	10004355
TS100-12-DRx-1350-16-HB	1,5	95	60	38	10098108
TS100-12-DRx-1400-16-HB	1,5	95	60	38	10098108
TS100-12-DRx-1450-16-HB	1,5	95	60	38	10098108
TS100-12-DRx-1500-16-HB	1,5	95	60	38	10098108
TS100-12-DRx-1550-18-HB	1,5	95	60	38	10098108
TS100-12-DRx-1650-18-HB	2	95	60	38	10098109
TS100-12-DRx-1750-18-HB	2	95	60	38	10098109
TS100-12-DRx-1850-20-HB	2	95	60	38	10098109
TS100-12-DRx-1950-20-HB	2	95	60	38	10098109
TS100-12-DRx-2050-25-HB	2	95	60	38	10098109
TS100-12-DRx-2150-25-HB	2	95	60	38	10098109
TS100-12-DRx-2250-25-HB	2	95	60	38	10098109
TS100-12-DRx-2350-25-HB	2	95	60	38	10098109
TS100-18-DRx-2450-25-HB	2,5	95	60	38	10098110
TS100-18-DRx-2550-25-HB	2,5	95	60	38	10098110
TS100-18-DRx-2650-25-HB	2,5	95	60	38	10098110
TS100-18-DRx-2750-25-HB	2,5	95	60	38	10098110
TS100-18-DRx-2850-32-HB	2,5	95	60	38	10098110
TS100-18-DRx-2950-32-HB	2,5	95	60	38	10098110
TS100-18-DRx-3050-32-HB	2,5	95	60	38	10098110
TS100-18-DRx-3150-32-HB	2,5	95	60	38	10098110
TS100-18-DRx-3250-32-HB	3	100	60	38	10006234
TS100-18-DRx-3350-32-HB	3	100	60	38	10006234
TS100-18-DRx-3450-32-HB	3	100	60	38	10006234
TS100-18-DRx-3550-40-HB	3	100	60	38	10006234
TS100-18-DRx-3750-40-HB	3	100	60	38	10006234
TS100-18-DRx-3950-40-HB	3	100	60	38	10006234
TS100-18-DRx-4150-40-HB	4	100	60	38	10006235
TS100-18-DRx-4350-40-HB	4	100	60	38	10006235

Vite di serraggio con rivestimento speciale

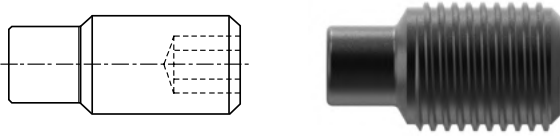

Tipo di supporto	Grano filettato	Codice	
Tipo di supporto	Grano filettato	Coppia di serraggio [Nm]	Codice
TS100-12-DRx-1200-14-HB	M2,5x5	1,0	30259117
TS100-12-DRx-1250-14-HB	M2,5x6	1,0	30259118
TS100-12-DRx-1300-14-HB	M2,5x6	1,0	30259118
TS100-12-DRx-1350-16-HB	M3x6	1,3	30259119
TS100-12-DRx-1400-16-HB	M3x6	1,3	30259119
TS100-12-DRx-1450-16-HB	M3x7	1,3	30193231
TS100-12-DRx-1500-16-HB	M3x7	1,3	30193231
TS100-12-DRx-1550-18-HB	M3x7	1,3	30193231
TS100-12-DRx-1650-18-HB	M4x0,5x7,5	3,5	30193232
TS100-12-DRx-1750-18-HB	M4x0,5x7,5	3,5	30193232
TS100-12-DRx-1850-20-HB	M4x0,5x7,5	3,5	30193232
TS100-12-DRx-1950-20-HB	M4x0,5x7,5	3,5	30193232
TS100-12-DRx-2050-25-HB	M4x0,5x10	3,5	30193233
TS100-12-DRx-2150-25-HB	M4x0,5x10	3,5	30193233
TS100-12-DRx-2250-25-HB	M4x0,5x10	3,5	30193233
TS100-12-DRx-2350-25-HB	M4x0,5x10	3,5	30193233
TS100-18-DRx-2450-25-HB	M5x0,5x11	4,0	30193234
TS100-18-DRx-2550-25-HB	M5x0,5x11	4,0	30193234
TS100-18-DRx-2650-25-HB	M5x0,5x11	4,0	30193234
TS100-18-DRx-2750-25-HB	M5x0,5x11	4,0	30193234
TS100-18-DRx-2850-32-HB	M5x0,5x14	4,0	30193235
TS100-18-DRx-2950-32-HB	M5x0,5x14	4,0	30193235
TS100-18-DRx-3050-32-HB	M5x0,5x14	4,0	30193235
TS100-18-DRx-3150-32-HB	M5x0,5x14	4,0	30193235
TS100-18-DRx-3250-32-HB	M6x0,5x16	6,0	30320812
TS100-18-DRx-3350-32-HB	M6x0,5x16	6,0	30320812
TS100-18-DRx-3450-32-HB	M6x0,5x16	6,0	30320812
TS100-18-DRx-3550-40-HB	M6x0,5x18	6,0	30320811
TS100-18-DRx-3750-40-HB	M6x0,5x18	6,0	30320811
TS100-18-DRx-3950-40-HB	M6x0,5x20	6,0	30320810
TS100-18-DRx-4150-40-HB	M8x1x20	10,0	30320806
TS100-18-DRx-4350-40-HB	M8x1x20	10,0	30320806

Parametri di lavorazione consigliati per punte ad inserto intercambiabile TTD

Avanzamento e velocità di taglio

Tipo 01 - Uni-Plus

GTM*		Materiale	Resistenza/durezza [N/mm ²] [HRC]
P1	P1.1	Acciai da costruzione, automatici, da cementazione e da bonifica, non legati	< 700
	P1.2	Acciai da costruzione, automatici, da cementazione e da bonifica, non legati	< 1.200
P2	P2.1	Acciai da niturazione, da cementazione e da bonifica, legati	< 900
	P2.2	Acciai da niturazione, da cementazione e da bonifica, legati	< 1.400
P3	P3.1	Acciai per utensili, per cuscinetti volventi, armonici e per lavorazioni veloci**	< 800
	P3.2	Acciai per utensili, per cuscinetti volventi, armonici e per lavorazioni veloci**	< 1.000
P3	P3.3	Acciai per utensili, per cuscinetti volventi, armonici e per lavorazioni veloci**	< 1.500
	P5.1	Acciaio fuso	
K1	K1.1	Ghisa con grafite lamellare (ghisa grigia), GJL	< 300
	K2.1	Ghisa con grafite sferoidale, GJS	< 500
K2	K2.2	Ghisa con grafite sferoidale, GJS	≤ 800
	K2.3	Ghisa con grafite sferoidale, GJS	> 800
K3	K3.1	Ghisa con grafite vermicolare, GJV; acciaio fuso malleabile, GJM	< 500
	K3.2	Ghisa con grafite vermicolare, GJV; acciaio fuso malleabile, GJM	> 500

Tipo 04 - Steel

GTM*		Materiale	Resistenza/durezza [N/mm ²] [HRC]
P1	P1.1	Acciai da costruzione, automatici, da cementazione e da bonifica, non legati	< 700
	P1.2	Acciai da costruzione, automatici, da cementazione e da bonifica, non legati	< 1.200
P2	P2.1	Acciai da niturazione, da cementazione e da bonifica, legati	< 900
	P2.2	Acciai da niturazione, da cementazione e da bonifica, legati	< 1.400
P3	P3.1	Acciai per utensili, per cuscinetti volventi, armonici e per lavorazioni veloci**	< 800
	P3.2	Acciai per utensili, per cuscinetti volventi, armonici e per lavorazioni veloci**	< 1.000
P3	P3.3	Acciai per utensili, per cuscinetti volventi, armonici e per lavorazioni veloci**	< 1.500
	P4.1	Acciai inossidabili, ferritici e martensitici	
P5	P5.1	Acciaio fuso	
P6	P6.1	Acciaio fuso, ferritico e martensitico	
K1	K1.1	Ghisa con grafite lamellare (ghisa grigia), GJL	< 300
	K2.1	Ghisa con grafite sferoidale, GJS	< 500
K2	K2.2	Ghisa con grafite sferoidale, GJS	≤ 800
	K2.3	Ghisa con grafite sferoidale, GJS	> 800
K3	K3.1	Ghisa con grafite vermicolare, GJV; acciaio fuso malleabile, GJM	< 500
	K3.2	Ghisa con grafite vermicolare, GJV; acciaio fuso malleabile, GJM	> 500

Tipo 03 - Alu

GTM*		Materiale	Resistenza/durezza [N/mm ²] [HRC]
N1	N1.1	Alluminio, non legato e legato < 3% Si	
	N1.2	Alluminio, legato ≤ 7% Si	
	N1.3	Alluminio, legato > 7-12% Si	
	N1.4	Alluminio, legato > 12% Si	
N2	N2.1	Rame, non legato e bassolegato	< 300
	N2.2	Rame, legato	> 300
	N2.3	Ottone, bronzo, ghisa rossa	< 1.200

* Gruppi di materiale MAPAL

** Qualora la somma dei componenti di lega Cr, Mo, Ni, V, W equivalesse a > 8%, selezionare il gruppo di materiale MAPAL immediatamente superiore.

	Velocità di taglio v_c [m/min]				Avanzamento f [mm] con diametro punta					
	Adduzione interna del refrigerante	Raffreddamento esterno	MQL	Aria	12,00	15,50	19,50	25,00	32,00	40,00
	110	100	100		0,23	0,26	0,29	0,32	0,33	0,33
	100	85	85		0,29	0,33	0,37	0,40	0,41	0,41
	110	95	95		0,27	0,31	0,35	0,37	0,39	0,39
	75	65	65		0,22	0,25	0,27	0,30	0,31	0,31
	85	70	70		0,24	0,28	0,31	0,34	0,35	0,35
	65	60	60		0,20	0,23	0,25	0,27	0,28	0,29
	65	50	55		0,16	0,18	0,20	0,21	0,22	0,22
	110	95	95		0,27	0,31	0,35	0,37	0,39	0,39
	110	75	75	75	0,34	0,39	0,44	0,48	0,49	0,49
	145	90	110	110	0,31	0,36	0,40	0,44	0,45	0,46
	90	70	70		0,27	0,31	0,35	0,38	0,39	0,39
	55	35	45		0,18	0,21	0,23	0,25	0,26	0,26
	80	70	70		0,29	0,34	0,37	0,40	0,42	0,42
	70	65	65		0,23	0,27	0,30	0,32	0,33	0,33

	Velocità di taglio v_c [m/min]				Avanzamento f [mm] con diametro punta					
	Adduzione interna del refrigerante	Raffreddamento esterno	MQL	Aria	12,00	15,50	19,50	25,00	32,00	40,00
	110	100	100		0,26	0,30	0,34	0,36	0,38	0,38
	100	85	85		0,33	0,38	0,42	0,46	0,47	0,47
	110	95	95		0,31	0,36	0,40	0,43	0,45	0,45
	75	65	65		0,25	0,28	0,31	0,34	0,35	0,35
	85	70	70		0,28	0,32	0,36	0,39	0,40	0,41
	65	60	60		0,23	0,26	0,29	0,32	0,33	0,33
	65	50	55		0,18	0,20	0,23	0,24	0,25	0,25
	65	50	55		0,18	0,21	0,24	0,25	0,26	0,27
	110	95	95		0,31	0,36	0,40	0,43	0,45	0,45
	110	75	75	75	0,37	0,44	0,49	0,53	0,55	0,55
	145	90	110	110	0,35	0,40	0,45	0,49	0,50	0,51
	90	70	70		0,30	0,35	0,39	0,42	0,43	0,43
	55	35	45		0,20	0,23	0,25	0,27	0,28	0,29
	80	70	70		0,32	0,37	0,41	0,45	0,47	0,47
	70	65	65		0,26	0,30	0,33	0,35	0,37	0,37

	Velocità di taglio v_c [m/min]				Avanzamento f [mm] con diametro punta					
	Adduzione interna del refrigerante	Raffreddamento esterno	MQL	Aria	12,00	15,50	19,50	25,00	32,00	40,00
	300	200	250		0,23	0,26	0,29	0,32	0,33	0,33
	250	180	200		0,30	0,35	0,39	0,42	0,43	0,43
	220	150	180		0,30	0,35	0,39	0,42	0,43	0,43
	180	120	150		0,30	0,35	0,39	0,42	0,43	0,43
	140	100			0,23	0,26	0,29	0,32	0,33	0,33
	120	90			0,30	0,35	0,39	0,42	0,43	0,43
	200	160	160	120	0,37	0,44	0,49	0,53	0,55	0,55

I parametri di lavorazione indicati sono valori orientativi.

I dati ottimali per la specifica applicazione devono essere rilevati eseguendo diversi tentativi o durante l'effettiva lavorazione.

Parametri di lavorazione consigliati per punte ad inserto intercambiabile TTD

Avanzamento e velocità di taglio

Tipo 02 - Inox

GTM*		Materiale	Resistenza/durezza [N/mm ²] [HRC]
P	P1	P1.1 Acciai da costruzione, automatici, da cementazione e da bonifica, non legati	< 700
		P1.2 Acciai da costruzione, automatici, da cementazione e da bonifica, non legati	< 1.200
	P2	P2.1 Acciai da niturazione, da cementazione e da bonifica, legati	< 900
		P2.2 Acciai da niturazione, da cementazione e da bonifica, legati	< 1.400
	P3	P3.1 Acciai per utensili, per cuscinetti volventi, armonici e per lavorazioni veloci**	< 800
		P3.2 Acciai per utensili, per cuscinetti volventi, armonici e per lavorazioni veloci**	< 1.000
		P3.3 Acciai per utensili, per cuscinetti volventi, armonici e per lavorazioni veloci**	< 1.500
	P4	P4.1 Acciai inossidabili, ferritici e martensitici	
	P5	P5.1 Acciaio fuso	
	P6	P6.1 Acciaio fuso, ferritico e martensitico	
M	M1	M1.1 Acciai inossidabili, austenitici	< 700
		M1.2 Acciai inossidabili, ferritici/austenitici (Duplex)	< 1.000
	M2	M2.1 Acciaio fuso inossidabile, austenitico	< 700
	M3	M3.1 Acciaio fuso inossidabile, ferritico/austenitico (Duplex)	< 1.000
K	K1	K1.1 Ghisa con grafite lamellare (ghisa grigia), GJL	< 300
		K2.1 Ghisa con grafite sferoidale, GJS	< 500
	K2	K2.2 Ghisa con grafite sferoidale, GJS	≤ 800
		K2.3 Ghisa con grafite sferoidale, GJS	> 800
	K3	K3.1 Ghisa con grafite vermicolare, GJV; acciaio fuso malleabile, GJM	< 500
		K3.2 Ghisa con grafite vermicolare, GJV; acciaio fuso malleabile, GJM	> 500
N2	N2.1 Rame, non legato e bassolegato	< 300	
	N2.2 Rame, legato	> 300	
	N2.3 Ottone, bronzo, ghisa rossa	< 1.200	
S	S1	S1.1 Titanio, leghe di titanio	< 400
		S2.1 Titanio, leghe di titanio	< 1.200
	S2	S2.2 Titanio, leghe di titanio	> 1.200
		S3.1 Nichel, non legato e legato	< 900
	S3	S3.2 Nichel, non legato e legato	> 900
		S4.1 Superlega resistente ad alte temperature a base di Ni, Co e Fe	
	S5	S5.1 Leghe di tungsteno e molibdeno	

Tipo 05 - Iron

GTM*		Materiale	Resistenza/durezza [N/mm ²] [HRC]
K	K1	K1.1 Ghisa con grafite lamellare (ghisa grigia), GJL	< 300
		K2.1 Ghisa con grafite sferoidale, GJS	< 500
	K2	K2.2 Ghisa con grafite sferoidale, GJS	≤ 800
		K2.3 Ghisa con grafite sferoidale, GJS	> 800
	K3	K3.1 Ghisa con grafite vermicolare, GJV; acciaio fuso malleabile, GJM	< 500
		K3.2 Ghisa con grafite vermicolare, GJV; acciaio fuso malleabile, GJM	> 500

* Gruppi di materiale MAPAL

** Qualora la somma dei componenti di lega Cr, Mo, Ni, V, W equivalesse a > 8%, selezionare il gruppo di materiale MAPAL immediatamente superiore.

	Velocità di taglio v_c [m/min]				Avanzamento f [mm] con diametro punta					
	Adduzione interna del refrigerante	Raffreddamento esterno	MQL	Aria	12,00	15,50	19,50	25,00	32,00	40,00
	100	90	90		0,21	0,24	0,26	0,28	0,30	0,30
	90	75	75		0,26	0,30	0,33	0,36	0,37	0,37
	100	85	85		0,24	0,28	0,31	0,34	0,35	0,35
	70	60	60		0,19	0,22	0,25	0,27	0,28	0,28
	75	65	65		0,22	0,25	0,28	0,30	0,32	0,32
	60	55	55		0,18	0,21	0,23	0,25	0,26	0,26
	60	45	50		0,14	0,16	0,18	0,19	0,20	0,20
	60	45	50		0,14	0,17	0,18	0,20	0,21	0,21
	100	85	85		0,24	0,28	0,31	0,34	0,35	0,35
	60	45	50		0,14	0,17	0,18	0,20	0,21	0,21
	55	35	35		0,18	0,21	0,24	0,25	0,26	0,27
	50	30	30		0,16	0,18	0,20	0,22	0,23	0,23
	55	35	35		0,18	0,21	0,24	0,25	0,26	0,27
	50	30	30		0,16	0,18	0,20	0,22	0,23	0,23
	95	70	70	70	0,34	0,39	0,44	0,48	0,49	0,49
	130	80	95	95	0,31	0,36	0,40	0,44	0,45	0,46
	80	60	60		0,27	0,31	0,35	0,38	0,39	0,39
	50	30	40		0,18	0,21	0,23	0,25	0,26	0,26
	70	65	65		0,29	0,34	0,37	0,40	0,42	0,42
	65	55	55		0,23	0,27	0,30	0,32	0,33	0,33
	140	100			0,23	0,26	0,29	0,32	0,33	0,33
	120	90			0,30	0,35	0,39	0,42	0,43	0,43
	200	160	160	120	0,37	0,44	0,49	0,53	0,55	0,55
	40	25			0,16	0,18	0,21	0,22	0,23	0,23
	30	20			0,14	0,16	0,18	0,19	0,20	0,20
	25	15			0,11	0,13	0,15	0,16	0,16	0,17
	20	15			0,09	0,11	0,12	0,13	0,13	0,13
	15	10			0,11	0,13	0,15	0,16	0,16	0,17
	15	10			0,09	0,11	0,12	0,13	0,13	0,13
	15	10			0,09	0,11	0,12	0,13	0,13	0,13

	Velocità di taglio v_c [m/min]				Avanzamento f [mm] con diametro punta					
	Adduzione interna del refrigerante	Raffreddamento esterno	MQL	Aria	12,00	15,50	19,50	25,00	32,00	40,00
	120	85	85	85	0,45	0,52	0,58	0,63	0,66	0,66
	160	100	120	120	0,42	0,48	0,54	0,58	0,60	0,61
	100	75	75		0,36	0,42	0,46	0,50	0,52	0,52
	60	40	50		0,24	0,28	0,30	0,33	0,34	0,34
	90	80	80		0,39	0,45	0,50	0,54	0,56	0,56
	80	70	70		0,31	0,36	0,39	0,43	0,44	0,44

I parametri di lavorazione indicati sono valori orientativi.

I dati ottimali per la specifica applicazione devono essere rilevati eseguendo diversi tentativi o durante l'effettiva lavorazione.

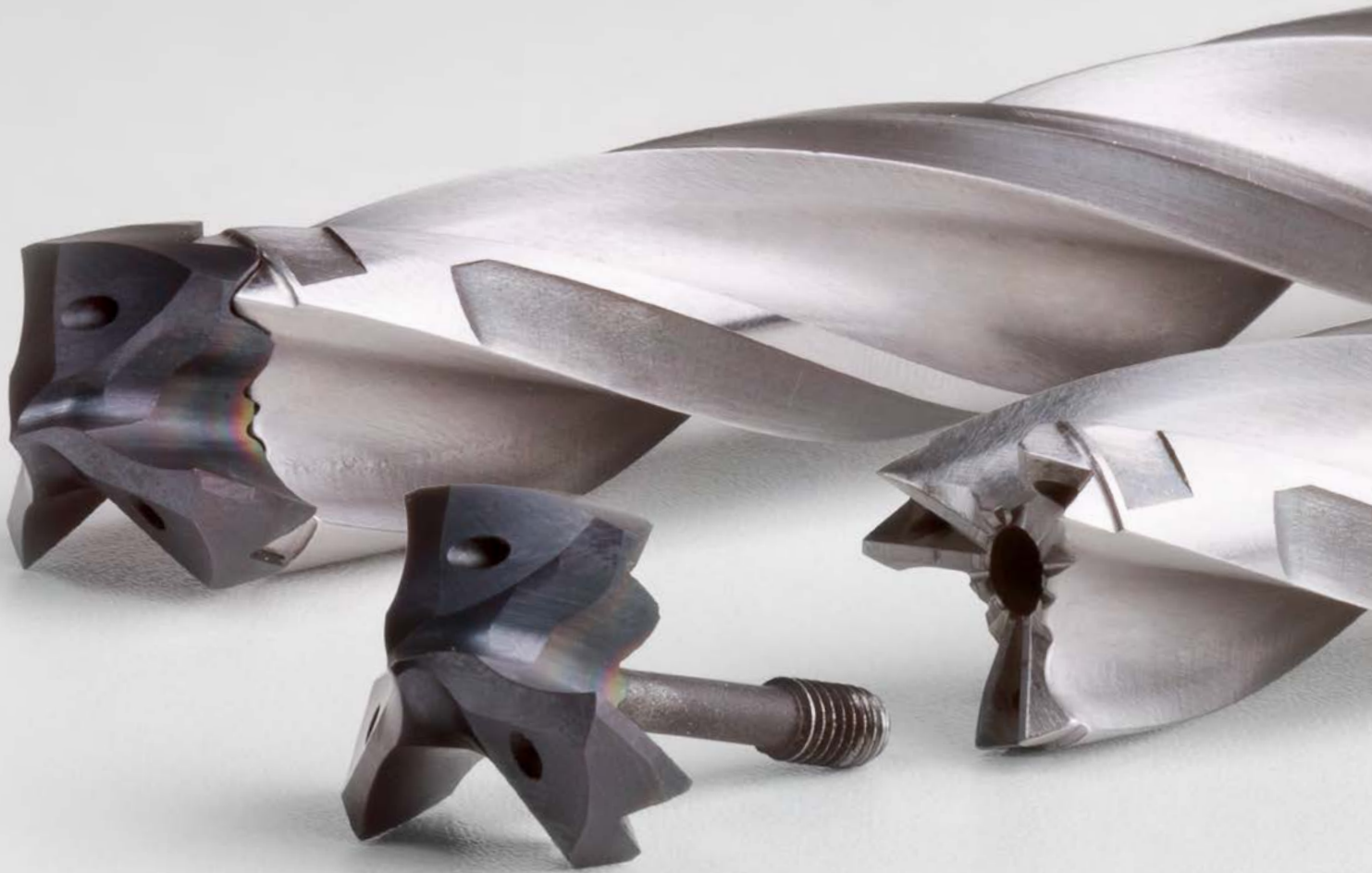

PUNTA AD INSERTO INTERCAMBIABILE TTD-TRITAN

Impiego di metallo duro ridotto al minimo, con stabilità e precisioni elevate

Anche Tritan-Drill a tre taglienti è disponibile come variante a testina intercambiabile.

La testina e il supporto dell'utensile sono collegati da una dentatura Hirth. Si tratta di un innesto particolarmente stabile, che consente di mantenere, anche nella variante a testina intercambiabile, tutti i vantaggi dell'utensile e lo stesso livello di efficienza e prestazioni del corrispondente utensile in metallo duro integrale. La stabilità dell'innesto è dovuta, tra l'altro, alla presenza dei tre taglienti, caratteristica predestinata per un sistema a testina intercambiabile.

Grazie ai tre taglienti, infatti, la sollecitazione dell'innesto è omogenea: questo significa che le forze generate in fase di asportazione truciolo vengono trasferite in modo uniforme al supporto utensile in acciaio. Inoltre l'innesto garantisce una trasmissione della coppia ottimale, con una precisione di cambio utensile e di concentricità particolarmente elevata.

Rispetto alle punte ad inserto intercambiabile a due taglienti in metallo duro integrale, TTD-Tritan consente avanzamenti maggiori anche del doppio.

Il risultato: possibilità di lavorare in modo stabile e sicuro anche in situazioni di foratura particolarmente difficili, come nel caso di ingresso obliquo del foro o di fori obliqui. L'utensile si centra in modo ottimale grazie alla marcata geometria della punta di foratura, garantendo un'eccellente circolarità. E tutto questo con costi contenuti rispetto alle punte in metallo duro integrale. Perché con il nuovo sistema a testine intercambiabili, il costoso metallo duro è limitato alla testa dell'utensile. Questo garantisce costi ridotti anche in caso di grandi diametri.

Caratteristiche utensile nel dettaglio

Codolo cilindrico con superficie di serraggio: garantisce il serraggio sicuro e una trasmissione ottimale della forza

Tre vani truciolo per un'asportazione ottimale

Punta ad inserto intercambiabile a tre taglienti

Materiale del corpo punta pregiato e temprato

Volume di gamma: sono disponibili versioni in tutte le lunghezze

Dentatura Hirth con sistema anti-sfilamento

Punta innovativa

Tagliente trasversale autocentrante

IN SINTESI

- Punta ad inserto intercambiabile a tre taglienti
- Range di \varnothing da 12,00 a 32,49 mm
- Profondità di foratura 3 | 5 e 8xD
- Con adduzione interna del refrigerante
- Facile utilizzo
- Possibilità di sostituzione della testina direttamente nella macchina

CARATTERISTICHE E PRESTAZIONI

- Avanzamento maggiore fino al doppio rispetto alle punte ad inserto intercambiabile a due taglienti
- Elevata precisione di concentricità e di cambio utensile
- Ideale in caso di ingresso obliquo del foro
- L'utensile si centra grazie alla marcata punta di foratura
- Elevata trasmissione della coppia

VANTAGGI

- Significativi incrementi della velocità di avanzamento e della durata utile
- Geometria Tritan per ottimi risultati di foratura
- Elevata sicurezza dei processi e stabilità anche in situazioni di foratura difficili
- Sollecitazione omogenea dell'innesto grazie a tre taglienti

Testina di foratura intercambiabile TTD-Tritan

In metallo duro integrale, adduzione interna del refrigerante
Tipo 01 - Uni

Versione:

Diametro punta: 12,00 – 32,49 mm
Tolleranza di foratura: IT 9 (raggiungibile)
Materiale da taglio: HP926
Numero di taglienti: 3
Numero margini di guida: 3
Angolo tra taglienti: 140°

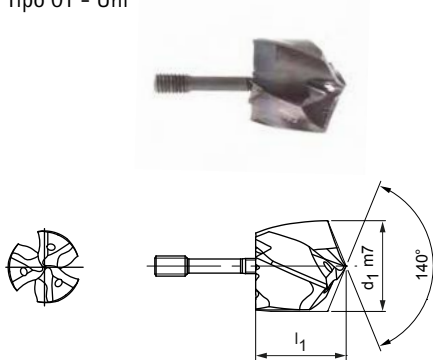

Serie selezionata per il magazzino

d ₁ da 13,50 a 20,00		
d ₁ m7	Specifiche	Codice
13,50	TTD300-3F01-1350-HP926	30871173
14,00	TTD300-3F01-1400-HP926	30871178
14,40	TTD300-3F01-1440-HP926	30871182
14,60	TTD300-3F01-1460-HP926	30871184
15,00	TTD300-3F01-1500-HP926	30871188
15,10	TTD300-3F01-1510-HP926	30871189
15,20	TTD300-3F01-1520-HP926	30871190
15,38	TTD300-3F01-1538-HP926	31290822
15,40	TTD300-3F01-1540-HP926	30871192
16,00	TTD300-3F01-1600-HP926	30871198
16,50	TTD300-3F01-1650-HP926	30871203
17,00	TTD300-3F01-1700-HP926	30871209
17,50	TTD300-3F01-1750-HP926	30871214
18,00	TTD300-3F01-1800-HP926	30871219
18,50	TTD300-3F01-1850-HP926	30871224
19,00	TTD300-3F01-1900-HP926	30871229
19,80	TTD300-3F01-1980-HP926	30871237
20,00	TTD300-3F01-2000-HP926	30871239

d ₁ da 20,50 a 32,00		
d ₁ m7	Specifiche	Codice
20,50	TTD300-3F01-2050-HP926	30871244
21,00	TTD300-3F01-2100-HP926	30871249
22,00	TTD300-3F01-2200-HP926	30871259
24,00	TTD300-3F01-2400-HP926	30871279
24,70	TTD300-3F01-2470-HP926	30871287
25,00	TTD300-3F01-2500-HP926	30871290
25,10	TTD300-3F01-2510-HP926	30871291
25,20	TTD300-3F01-2520-HP926	30871292
26,00	TTD300-3F01-2600-HP926	30871300
26,10	TTD300-3F01-2610-HP926	30871301
26,50	TTD300-3F01-2650-HP926	30871305
27,00	TTD300-3F01-2700-HP926	30871310
27,10	TTD300-3F01-2710-HP926	30871311
28,00	TTD300-3F01-2800-HP926	30871320
28,50	TTD300-3F01-2850-HP926	30871325
31,00	TTD300-3F01-3100-HP926	30871350
32,00	TTD300-3F01-3200-HP926	30871360

Caratteristiche configurabili



Diametro:
Diametro a libera scelta a passi da
0,01 mm



Specifiche:
TTD300-3F01-[diametro]-HP929

Dimensioni serie configurabile

d ₁ min.	d ₁ max.
12,00	32,49

Esempio:
TTD300-4F03-1401-HP619

Diametro utensile d₁ = 14,01 mm

Misure in mm.

Per i parametri di lavorazione consigliati, vedere la fine del capitolo.
Versioni speciali e altri rivestimenti disponibili su richiesta.

Supporto per testina intercambiabile TTS

Versione:

Diametro punta:

12,00 - 32,49 mm

Sistema di cambio:

Serraggio centrale tramite foro del refrigerante

Nota:

Chiave di montaggio non inclusa nella fornitura.

TTS300 con sistema di serraggio assiale per punte ad inserto intercambiabile TTD-Tritan (3xD), adduzione interna del refrigerante

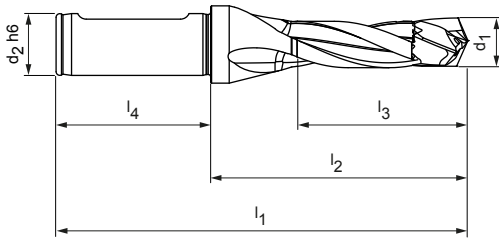
**Serie selezionata per il magazzino**

Dimensioni						Forma del codolo HB	
d ₁	d ₂ h6	l ₁	l ₂	l ₃	l ₄	Specifiche	Codice
14,00 - 14,49	16	120	72	48	48	TTS300B-1400-DR3-ZYL-16-MN	30839684
14,50 - 14,99	16	122	74	49	48	TTS300B-1450-DR3-ZYL-16-MN	30839685
15,00 - 15,49	16	124	76	51	48	TTS300B-1500-DR3-ZYL-16-MN	30839686
17,50 - 18,49	20	140	90	61	50	TTS300B-1750-DR3-ZYL-20-MN	30839689
18,50 - 19,49	25	150	94	64	56	TTS300B-1850-DR3-ZYL-25-MN	30839690
20,50 - 21,49	25	159	103	71	56	TTS300B-2050-DR3-ZYL-25-MN	30839692
21,50 - 22,49	25	164	108	74	56	TTS300B-2150-DR3-ZYL-25-MN	30839693
24,50 - 25,49	32	182	122	84	60	TTS300B-2450-DR3-ZYL-32-MN	30839696
26,50 - 27,49	32	191	131	91	60	TTS300B-2650-DR3-ZYL-32-MN	30839698

Disponibile su richiesta

Dimensioni						Forma del codolo HB	
d ₁	d ₂ h6	l ₁	l ₂	l ₃	l ₄	Specifiche	Codice
12,00 - 12,49	16	111	63	39	48	TTS300B-1200-DR3-ZYL-16-MN	30839680
12,50 - 12,99	16	113	65	43	48	TTS300B-1250-DR3-ZYL-16-MN	30839681
13,00 - 13,49	16	115	67	45	48	TTS300B-1300-DR3-ZYL-16-MN	30839682
13,50 - 13,99	16	117	69	46	48	TTS300B-1350-DR3-ZYL-16-MN	30839683
15,50 - 16,49	20	131	81	54	50	TTS300B-1550-DR3-ZYL-20-MN	30839687
16,50 - 17,49	20	135	85	58	50	TTS300B-1650-DR3-ZYL-20-MN	30839688
19,50 - 20,49	25	155	99	68	56	TTS300B-1950-DR3-ZYL-25-MN	30839691
22,50 - 23,49	25	168	112	78	56	TTS300B-2250-DR3-ZYL-25-MN	30839694
23,50 - 24,49	25	173	117	81	56	TTS300B-2350-DR3-ZYL-25-MN	30839695
25,50 - 26,49	32	186	126	87	60	TTS300B-2550-DR3-ZYL-32-MN	30839697
27,50 - 28,49	32	195	135	94	60	TTS300B-2750-DR3-ZYL-32-MN	30839699
28,50 - 29,49	32	200	140	97	60	TTS300B-2850-DR3-ZYL-32-MN	30839700
29,50 - 30,49	32	204	144	101	60	TTS300B-2950-DR3-ZYL-32-MN	30839701
30,50 - 31,49	32	209	149	104	60	TTS300B-3050-DR3-ZYL-32-MN	30839702
31,50 - 32,49	32	213	153	107	60	TTS300B-3150-DR3-ZYL-32-MN	30839703

Misure in mm.

Versioni speciali disponibili su richiesta.

Supporto per testina intercambiabile TTS

Versione:

Diametro punta:
Sistema di cambio:

12,00 – 32,49 mm
Serraggio centrale tra-
mite foro del refrige-
rante

Nota:

Chiave di montaggio non inclusa nella fornitura.

TTS300 con sistema di serraggio assiale per punte ad inserto intercambiabile TTD-Tritan (5xD), adduzione interna del refrigerante

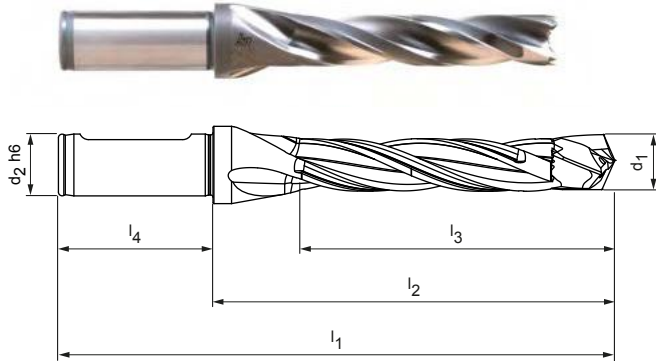
**Serie selezionata per il magazzino**

Dimensioni						Forma del codolo HB	
d ₁	d ₂ h6	l ₁	l ₂	l ₃	l ₄	Specifiche	Codice
14,00 - 14,49	16	149	101	77	48	TTS300B-1400-DR5-ZYL-16-MN	30839708
15,00 - 15,49	16	155	107	82	48	TTS300B-1500-DR5-ZYL-16-MN	30839710
16,50 - 17,49	20	170	120	93	50	TTS300B-1650-DR5-ZYL-20-MN	30839712
17,50 - 18,49	20	177	127	98	50	TTS300B-1750-DR5-ZYL-20-MN	30839713
23,50 - 24,49	25	222	166	130	56	TTS300B-2350-DR5-ZYL-25-MN	30839719
24,50 - 25,49	32	233	173	135	60	TTS300B-2450-DR5-ZYL-32-MN	30839720
26,50 - 27,49	32	246	186	146	60	TTS300B-2650-DR5-ZYL-32-MN	30839722

Disponibile su richiesta

Dimensioni						Forma del codolo HB	
d ₁	d ₂ h6	l ₁	l ₂	l ₃	l ₄	Specifiche	Codice
12,00 - 12,49	16	136	88	66	48	TTS300B-1200-DR5-ZYL-16-MN	30839704
12,50 - 12,99	16	139	91	69	48	TTS300B-1250-DR5-ZYL-16-MN	30839705
13,00 - 13,49	16	142	94	71	48	TTS300B-1300-DR5-ZYL-16-MN	30839706
13,50 - 13,99	16	145	97	74	48	TTS300B-1350-DR5-ZYL-16-MN	30839707
14,50 - 14,99	16	152	104	79	48	TTS300B-1450-DR5-ZYL-16-MN	30839709
15,50 - 16,49	20	164	114	87	50	TTS300B-1550-DR5-ZYL-20-MN	30839711
18,50 - 19,49	25	189	133	103	56	TTS300B-1850-DR5-ZYL-25-MN	30839714
19,50 - 20,49	25	196	140	109	56	TTS300B-1950-DR5-ZYL-25-MN	30839715
20,50 - 21,49	25	202	146	114	56	TTS300B-2050-DR5-ZYL-25-MN	30839716
21,50 - 22,49	25	209	153	119	56	TTS300B-2150-DR5-ZYL-25-MN	30839717
22,50 - 23,49	25	215	159	124	56	TTS300B-2250-DR5-ZYL-25-MN	30839718
25,50 - 26,49	32	239	179	140	60	TTS300B-2550-DR5-ZYL-32-MN	30839721
27,50 - 28,49	32	252	192	151	60	TTS300B-2750-DR5-ZYL-32-MN	30839723
28,50 - 29,49	32	259	199	156	60	TTS300B-2850-DR5-ZYL-32-MN	30839724
29,50 - 30,49	32	265	205	162	60	TTS300B-2950-DR5-ZYL-32-MN	30839725
30,50 - 31,49	32	272	212	167	60	TTS300B-3050-DR5-ZYL-32-MN	30839726
31,50 - 32,49	32	278	218	172	60	TTS300B-3150-DR5-ZYL-32-MN	30839727

Misure in mm.

Versioni speciali disponibili su richiesta.

Supporto per testina intercambiabile TTS

TTS300 con sistema di serraggio assiale per punte ad inserto intercambiabile TTD-Tritan (8xD), adduzione interna del refrigerante

Versione:

Diametro punta:
Sistema di cambio:

12,00 – 32,49 mm
Serraggio centrale tramite foro del refrigerante

Nota:

Chiave di montaggio non inclusa nella fornitura.

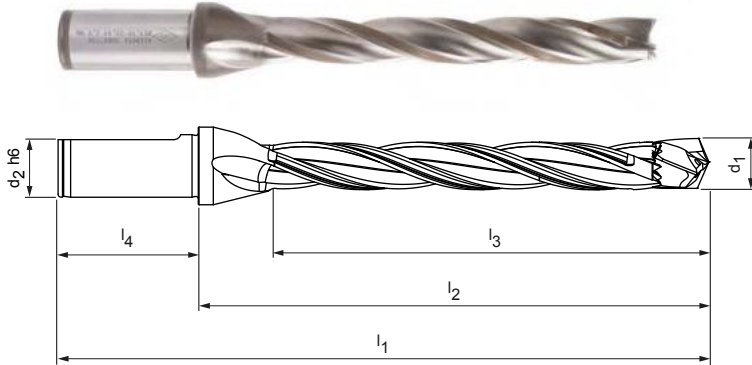
Serie selezionata per il magazzino

Dimensioni						Forma del codolo HB	
d_1	$d_2 h6$	l_1	l_2	l_3	l_4	Specifiche	Codice
15,50 - 16,49	20	213	163	137	50	TTS300B-1550-DR8-ZYL-20-MN	30867702
20,50 - 21,49	25	267	211	178	56	TTS300B-2050-DR8-ZYL-25-MN	30867707

Disponibile su richiesta

Dimensioni						Forma del codolo HB	
d_1	$d_2 h6$	l_1	l_2	l_3	l_4	Specifiche	Codice
12,00 - 12,49	16	173	125	104	48	TTS300B-1200-DR8-ZYL-16-MN	30867695
12,50 - 12,99	16	178	130	108	48	TTS300B-1250-DR8-ZYL-16-MN	30867696
13,00 - 13,49	16	183	135	112	48	TTS300B-1300-DR8-ZYL-16-MN	30867697
13,50 - 13,99	16	187	139	116	48	TTS300B-1350-DR8-ZYL-16-MN	30867698
14,00 - 14,49	16	192	144	120	48	TTS300B-1400-DR8-ZYL-16-MN	30867699
14,50 - 14,99	16	197	149	124	48	TTS300B-1450-DR8-ZYL-16-MN	30867700
15,00 - 15,49	16	202	154	129	48	TTS300B-1500-DR8-ZYL-16-MN	30867701
16,50 - 17,49	20	223	173	145	50	TTS300B-1650-DR8-ZYL-20-MN	30867703
17,50 - 18,49	20	232	182	153	50	TTS300B-1750-DR8-ZYL-20-MN	30867704
18,50 - 19,49	25	248	192	162	56	TTS300B-1850-DR8-ZYL-25-MN	30867705
19,50 - 20,49	25	257	201	170	56	TTS300B-1950-DR8-ZYL-25-MN	30867706
21,50 - 22,49	25	276	220	187	56	TTS300B-2150-DR8-ZYL-25-MN	30867708
22,50 - 23,49	25	286	230	195	56	TTS300B-2250-DR8-ZYL-25-MN	30867709
23,50 - 24,49	25	295	239	203	56	TTS300B-2350-DR8-ZYL-25-MN	30867710
24,50 - 25,49	32	309	249	212	60	TTS300B-2450-DR8-ZYL-32-MN	30867711
25,50 - 26,49	32	319	259	220	60	TTS300B-2550-DR8-ZYL-32-MN	30885879
26,50 - 27,49	32	328	268	228	60	TTS300B-2650-DR8-ZYL-32-MN	30867713
27,50 - 28,49	32	338	278	236	60	TTS300B-2750-DR8-ZYL-32-MN	30867714
28,50 - 29,49	32	342	282	245	60	TTS300B-2850-DR8-ZYL-32-MN	30867715
29,50 - 30,49	32	352	292	253	60	TTS300B-2950-DR8-ZYL-32-MN	30867716
30,50 - 31,49	32	361	301	261	60	TTS300B-3050-DR8-ZYL-32-MN	30867717
31,50 - 32,49	32	371	311	270	60	TTS300B-3150-DR8-ZYL-32-MN	30867718

Misure in mm.

Versioni speciali disponibili su richiesta.

Accessori e parti di ricambio per TTD-Tritan



Chiave TORX®

Range di diametro Testina di foratura intercambiabile TTD-Tritan	Torx	Coppia di serraggio vite speciale [Nm]	Codice
			per lunghezze supporto 3xD, 5xD e 8xD
12,00 - 12,49	6	0,4	30890316
12,50 - 12,99			
13,00 - 13,49			
13,50 - 13,99			
14,00 - 14,49	7	0,7	30890318
14,50 - 14,99			
15,00 - 15,49			
15,50 - 16,49			
16,50 - 17,49			
17,50 - 18,49	8	1,3	30890321
18,50 - 19,49			
19,50 - 20,49	10	2	30890323
20,50 - 21,49			
21,50 - 22,49			
22,50 - 23,49			
23,50 - 24,49			
24,50 - 25,49			
25,50 - 26,49	15	3,1	30890326
26,50 - 27,49			
27,50 - 28,49			
28,50 - 29,49		5,6	
29,50 - 30,49			
30,50 - 31,49			
31,50 - 32,49			

Chiave dinamometrica

Accessori	Range coppia di serraggio [Nm]	Codice
Chiave dinamometrica 	0,2 - 1,2	30911425
Chiave dinamometrica 	1,0 - 6,0	30911426

Impugnatura per chiave TORX®

Parte di ricambio	Codolo innesto	Codice
Multi impugnatura 	Esagono incassato 1/4"	30918896

Parametri di lavorazione consigliati per punte ad inserto intercambiabile TTD-Tritan

Avanzamento e velocità di taglio

Tipo 01 - Uni

GTM*		Materiale	Resistenza/durezza [N/mm ²] [HRC]
P	P1	P1.1 Acciai da costruzione, automatici, da cementazione e da bonifica, non legati	< 700
		P1.2 Acciai da costruzione, automatici, da cementazione e da bonifica, non legati	< 1.200
	P2	P2.1 Acciai da nitrurazione, da cementazione e da bonifica, legati	< 900
		P2.2 Acciai da nitrurazione, da cementazione e da bonifica, legati	< 1.400
	P3	P3.1 Acciai per utensili, per cuscinetti volventi, armonici e per lavorazioni veloci**	< 800
		P3.2 Acciai per utensili, per cuscinetti volventi, armonici e per lavorazioni veloci**	< 1.000
		P3.3 Acciai per utensili, per cuscinetti volventi, armonici e per lavorazioni veloci**	< 1.500
	P5	P5.1 Acciaio fuso	
K	K1	K1.1 Ghisa con grafite lamellare (ghisa grigia), GJL	< 300
		K2.1 Ghisa con grafite sferoidale, GJS	< 500
	K2	K2.2 Ghisa con grafite sferoidale, GJS	≤ 800
		K2.3 Ghisa con grafite sferoidale, GJS	> 800
	K3	K3.1 Ghisa con grafite vermicolare, GJV; acciaio fuso malleabile, GJM	< 500
		K3.2 Ghisa con grafite vermicolare, GJV; acciaio fuso malleabile, GJM	> 500

* Gruppi di materiale MAPAL

** Qualora la somma dei componenti di lega Cr, Mo, Ni, V, W equivalesse a > 8%, selezionare il gruppo di materiale MAPAL immediatamente superiore.

	Velocità di taglio v_c [m/min]				Avanzamento f [mm] con diametro punta					
	Adduzione interna del refrigerante	Raffreddamento esterno	MQL	Aria	12,00	14,50	17,50	21,50	26,00	32,00
	90	80	80		0,38	0,42	0,46	0,50	0,53	0,54
	80	70	70		0,47	0,53	0,58	0,63	0,66	0,68
	90	75	75		0,45	0,50	0,55	0,59	0,62	0,64
	65	55	55		0,36	0,40	0,43	0,47	0,49	0,51
	70	60	60		0,40	0,45	0,49	0,53	0,56	0,58
	55	50	50		0,33	0,37	0,40	0,43	0,46	0,47
	55	40	45		0,26	0,28	0,31	0,33	0,35	0,36
	90	75	75		0,45	0,50	0,55	0,59	0,62	0,64
	110	75	75	75	0,62	0,69	0,77	0,83	0,88	0,90
	145	90	110	110	0,57	0,64	0,71	0,77	0,81	0,83
	90	70	70		0,49	0,55	0,61	0,66	0,69	0,71
	55	35	45		0,33	0,37	0,40	0,43	0,46	0,47
	80	70	70		0,53	0,59	0,65	0,71	0,75	0,77
	70	65	65		0,43	0,47	0,52	0,56	0,59	0,61

I parametri di lavorazione indicati sono valori orientativi.

I dati ottimali per la specifica applicazione devono essere rilevati eseguendo diversi tentativi o durante l'effettiva lavorazione.



UTENSILI DI FORATURA CON INSERTI A FISSAGGIO MECCANICO

Utensili di foratura con inserti a fissaggio meccanico

Punta con inserto a fissaggio meccanico.....	240
Inserto a fissaggio radiale WOGT, tre taglienti	241

Allegato tecnico

Parametri di lavorazione consigliati per punte con inserto a fissaggio meccanico	242
Indicazioni per l'applicazione	744

UTENSILI DI FORATURA CON INSERTI A FISSAGGIO MECCANICO

I nuovi inserti a fissaggio meccanico per la foratura dell'alluminio convincono grazie a tre taglienti utili e un rivestimento diamantato in CVD ad alte prestazioni. I taglienti sono disponibili in cinque misure. Lo spettro di applicazioni è pertanto davvero ampio.

Gli strumenti personalizzati a uno o più gradini sono caratterizzati da una redditività estremamente elevata e da una grande maneggevolezza e semplicità d'utilizzo.



Guida pratica

Materiale: AISi1 v_c : 800 - 1000 m/min
 Diametro: 39,0 mm f : 0,30 - 0,45 mm
 Profondità di foratura: ≥ 65 mm

Durata utile per tagliente

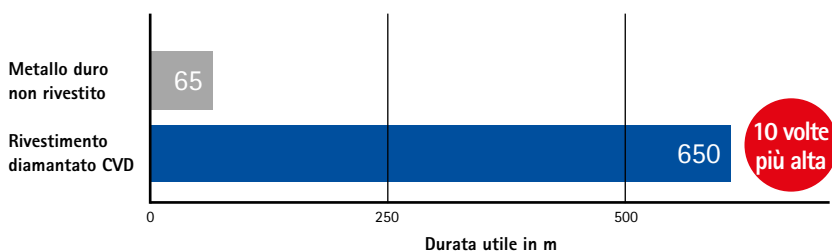

IN SINTESI

- Soluzioni su misura per: \varnothing 16 - 54,9 mm
- Foratura da AISi1 fino a AISi12
- Con adduzione interna del refrigerante, possibilità anche di lubrificazione minima
- A uno o più gradini con inserto a fissaggio meccanico o gradino in PCD

VANTAGGI

- Estrema redditività con massima produttività
- Vasta gamma di applicazioni
- Facile utilizzo

Inserti a fissaggio meccanico in cinque dimensioni diverse per range di diametro da 16 a 54,9 mm.

WOGT

Inserto a fissaggio radiale, tre taglienti



	Metallo duro	
Materiale	N	
	Al leg. ← resistente all'usura	Cu leg. → tenace
Tipo di materiale da taglio	HC698	
Versione dei bordi di taglio	X40	

Range di ϕ [mm]

WOGT030206N-...-...	16,0 - 20,9	31033174
WOGT040206N-...-...	21,0 - 25,9	31033175
WOGT053006N-...-...	26,0 - 30,9	31033177
WOGT063008N-...-...	31,0 - 44,9	30787196
WOGT073808N-...-...	45,0 - 54,9	31033178

Per il codice di denominazione vedere pagina 676.

Per il riepilogo dei materiali da taglio vedere pagina 672.

Accessori per inserti a fissaggio radiale

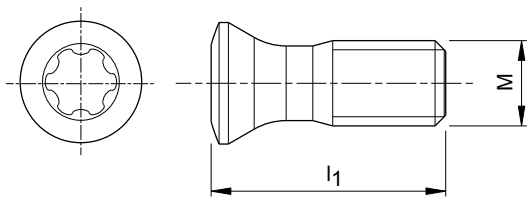

Inserto a fissaggio meccanico	Dimensione inserto	Vite di serraggio					Cacciavite
		Dimensioni [MxI]	Denominazione	Coppia di serraggio [Nm]	Dimensioni Torx	Codice	Codice
WOGT... 	0302	M2x4.95	MN659 M2x4.95-TX6-IP	0,4	TX6-IP	10002712	30414758
	0402	M2.2x6	MN659 M2.2x6-TX7-IP	0,9	TX7-IP	31074485	30414759
	0530	M3x8.5	MN659 M3x8.5-TX8-IP	1,5	TX8-IP	31074486	30414760
	0630	M3.5x9	MN659 M3.5x9-TX15-IP	2,8	TX15-IP	10105078	30414764
	0738	M4x9.4	MN659 M4x9.4-TX15-IP	3,5	TX15-IP	30480629	30414764

Parametri di lavorazione consigliati per punte con inserto a fissaggio meccanico

Avanzamento e velocità di taglio

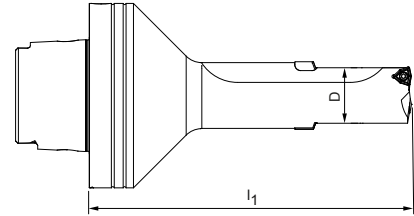

Punta con inserto a fissaggio meccanico

Valori iniziali relativi a velocità di taglio e avanzamento con WOGT...-X40-HC698

GTM*	Materiale	Resistenza/durezza [N/mm ²] [HRC]
N1	N1.1 Alluminio, non legato e legato < 3% Si	
	N1.2 Alluminio, legato ≤ 7% Si	
	N1.3 Alluminio, legato > 7-12% Si	
	N1.4 Alluminio, legato > 12% Si	
N2	N2.1 Rame, non legato e bassolegato	< 300
	N2.2 Rame, legato	> 300
	N2.3 Ottone, bronzo, ghisa rossa	< 1.200
N3	N3.1 Grafite	
N4	N4.1 Plastica, thermoplast	
	N4.2 Plastica, duroplast	
	N4.3 Plastica, materiali espansi	

Fattore di correzione: Foratura pilota/uscita della punta

l_1	v_c	f_z
3xD	0,8	0,7
4xD	0,7	0,6
5xD	0,6	0,5

	Velocità di taglio v_c [m/min]	Avanzamento f [mm] con range diametro punta [mm]				
		16,00 - 20,90	21,00 - 25,90	26,00 - 30,90	31,00 - 44,90	45,00 - 54,90
	300 - 1.000	0,08 - 0,20	0,12 - 0,22	0,14 - 0,30	0,16 - 0,40	0,20 - 0,45
	230 - 900	0,06 - 0,18	0,10 - 0,20	0,12 - 0,25	0,14 - 0,30	0,18 - 0,35
	220 - 800	0,05 - 0,15	0,08 - 0,18	0,10 - 0,20	0,12 - 0,25	0,15 - 0,30
	200 - 700	0,05 - 0,15	0,08 - 0,18	0,10 - 0,20	0,12 - 0,25	0,15 - 0,30

I parametri di lavorazione indicati sono valori orientativi.

I dati ottimali per la specifica applicazione devono essere rilevati eseguendo diversi tentativi o durante l'effettiva lavorazione.



FORATURA PILOTA

Punte pilota

Tritan-Spot-Drill-Steel	246
ECU-Centre-Drill	248
CPD-Spot-Drill	249
Supporto per testina intercambiabile CFS	250

Allegato tecnico

Parametri di lavorazione consigliati	251
--	-----

Tritan-Spot-Drill-Steel

Punta pilota NC in metallo duro integrale
SCD670, adduzione esterna del refrigerante

Versione:

Diametro punta: 4,00 – 20,00 mm
 Forma del codolo: HA (DIN 6535)
 Materiale da taglio: HP358
 Numero di taglienti: 3
 Angolo tra taglienti: 155°

Applicazione

Punta pilota NC specifica per Tritan-Drill-Steel.

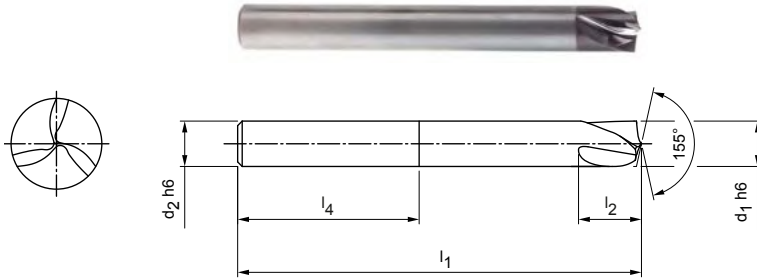

Serie selezionata per il magazzino

Dimensioni					Forma del codolo HA	
d ₁ h6	d ₂ h6	l ₁	l ₂	l ₄	Specifiche	Codice
4,00	4	55	6	28	SCD670-0400-3-0-155HA-HP358	30980587
5,00	6	62	7	36	SCD670-0500-3-0-155HA-HP358	30980588
6,00	6	66	9	36	SCD670-0600-3-0-155HA-HP358	30980589
8,00	8	79	11	36	SCD670-0800-3-0-155HA-HP358	30980590
10,00	10	89	14	40	SCD670-1000-3-0-155HA-HP358	30980592
12,00	12	102	17	45	SCD670-1200-3-0-155HA-HP358	30980594
16,00	16	115	23	48	SCD670-1600-3-0-155HA-HP358	30980595
20,00	20	131	28	50	SCD670-2000-3-0-155HA-HP358	30980596

Profondità di foratura pilota

d ₁ h6	d ₂ h6	l ₁	l ₂	l ₄	Massima Profondità di foratura pilota *	Minima Profondità di foratura pilota **
4,00	4	55	6	28	0,40	0,24
5,00	6	62	7	36	0,50	0,30
6,00	6	66	9	36	0,60	0,36
8,00	8	79	11	36	0,80	0,48
10,00	10	89	14	40	1,00	0,60
12,00	12	102	17	45	1,20	0,72
16,00	16	115	23	48	1,60	0,96
20,00	20	131	28	50	2,00	1,20

** 10% del Ø nominale

** 6% del Ø nominale

Misure in mm.

Per i parametri di lavorazione consigliati, vedere la fine del capitolo.

Versioni speciali e altri rivestimenti disponibili su richiesta.

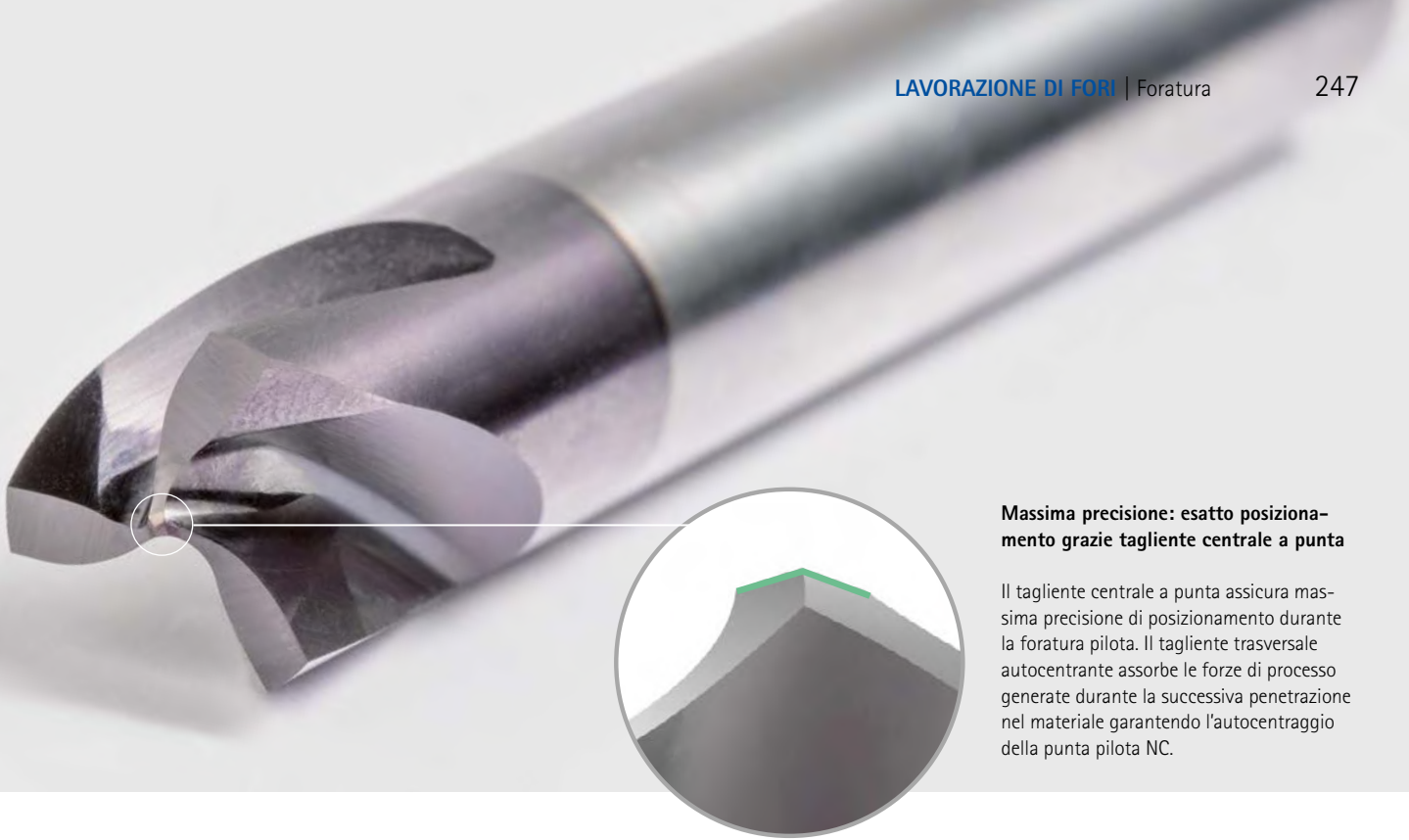

Massima precisione: esatto posizionamento grazie tagliente centrale a punta

Il tagliente centrale a punta assicura massima precisione di posizionamento durante la foratura pilota. Il tagliente trasversale autocentrante assorbe le forze di processo generate durante la successiva penetrazione nel materiale garantendo l'autocentraggio della punta pilota NC.

Tritan-Drill-Steel



Gli angoli tra taglienti di Tritan-Spot-Drill-Steel (155°) e Tritan-Drill-Steel (140°/145°) sono sinonimo di perfetta sinergia.

Tritan-Drill-Steel è disponibile in:



Strategia di foratura da 3xD a 12xD:

Profondità di foratura pilota massima: 10%
(Indicazione % del diametro nominale)

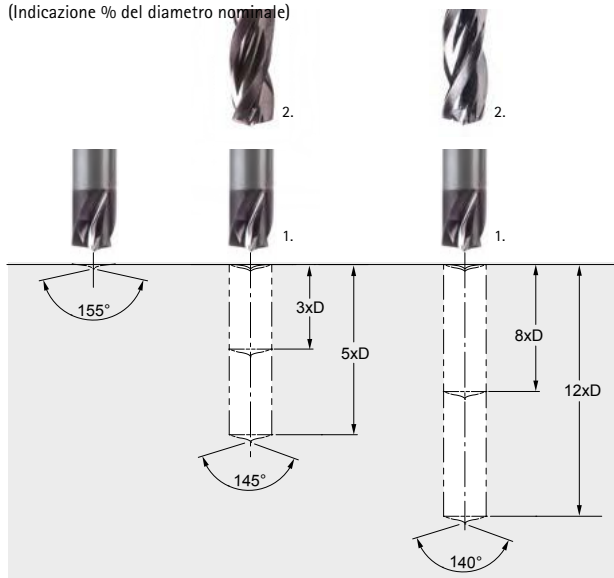

IN SINTESI

- Punta pilota NC a tre taglienti con angolo tra taglienti pari a 155°
- Ideale per uso con Tritan-Drill-Steel
- Alta precisione di posizionamento
- Tagliente trasversale autocentrante
- Idonea anche alle situazioni di foratura particolarmente difficili

ECU-Centre-Drill

Punta di centraggio in metallo duro integrale
SCD450

Versione:

Diametro punta: 0,50 – 2,50 mm
 Materiale da taglio: HU318
 Numero di taglienti: 2
 Numero margini di guida: 2
 Angolo tra taglienti: 120°/60°
 Angolo dell'elica: 5°

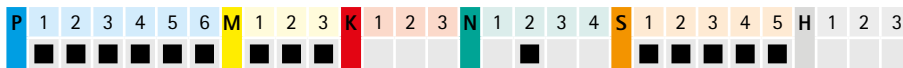
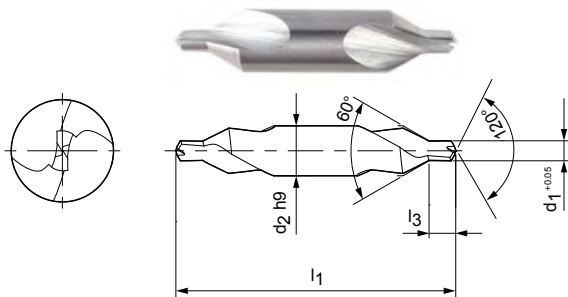

Serie selezionata per il magazzino

Dimensioni				Specifiche	Codice
d_1 (0 +0,05)	d_2 h9	l_1	l_3		
0,50*	3,15	20	0,8	SCD450-0050-2-2-120HA-HU318	30561506
0,80*	3,15	20	1,1	SCD450-0080-2-2-120HA-HU318	30561507
1,00	3,15	31,5	1,3	SCD450-0100-2-2-120HA-HU318	30561508
1,25	3,15	31,5	1,6	SCD450-0125-2-2-120HA-HU318	30561509
1,60	4	35,5	2	SCD450-0160-2-2-120HA-HU318	30561510
2,00	5	40	2,5	SCD450-0200-2-2-120HA-HU318	30561511
2,50	6,3	45	3,1	SCD450-0250-2-2-120HA-HU318	30561512

Misure in mm.

* Taglia da un lato.

Per i parametri di lavorazione consigliati, vedere la fine del capitolo.

Versioni speciali e altri rivestimenti disponibili su richiesta.

CPD-Spot-Drill

Versione con attacco CFS
CPD100

Versione:

Diametro punta: 8,00 - 20,00 mm
Materiale da taglio: HP338
Numero di taglienti: 2
Angolo dell'elica: 15°
Angolo tra taglienti: 90°

Applicazione

Foratura di centraggio.

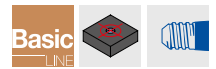
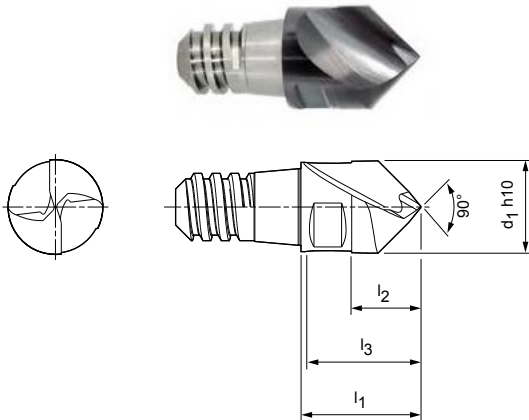

Serie selezionata per il magazzino

Dimensioni					z	a _p max.	SW	Specifiche	Codice
d ₁ h10	Dimensioni CFS	l ₁	l ₂	l ₃					
8,00	6	11	6	10	2	4	SW 6	CPD100-0800Z02-W090-06-HP338	30371388
10,00	8	13	7,5	12	2	5	SW 8	CPD100-1000Z02-W090-08-HP338	30371389
12,00	10	16	9	15	2	6	SW 10	CPD100-1200Z02-W090-10-HP338	30371390
16,00	12	20	12	18	2	8	SW 13	CPD100-1600Z02-W090-12-HP338	30371391
20,00	16	25	15	23	2	10	SW 16	CPD100-2000Z02-W090-16-HP338	30371393

Accessori

	Supporto per testina intercambiabile CFS CFS201	Pagina 250
---	--	------------

Misure in mm.

Per i parametri di lavorazione consigliati, vedere la fine del capitolo.

Versioni speciali e altri rivestimenti disponibili su richiesta.

Supporto per testina intercambiabile CFS

Versione conica, con adduzione interna del refrigerante
CFS201

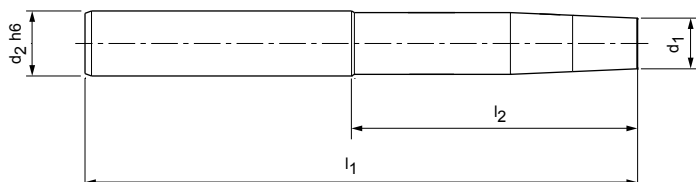

Versione in acciaio

Dimensione CFS	Dimensioni				Specifiche	Codice
	d_1	d_2 h6	l_1	l_2		
6	7,8	10	60	20	CFS201N-06-020-ZYL-HA10-S	30393776
8	9,8	16	70	30	CFS201N-08-030-ZYL-HA16-S	30393787
8	9,8	16	90	40	CFS201N-08-040-ZYL-HA16-S	30393788
10	11,8	16	70	30	CFS201N-10-030-ZYL-HA16-S	30393798
10	11,8	16	90	42	CFS201N-10-042-ZYL-HA16-S	30393799
12	15,8	20	80	30	CFS201N-12-030-ZYL-HA20-S	30393963
12	15,8	20	105	55	CFS201N-12-055-ZYL-HA20-S	30393964
16	19,8	25	90	40	CFS201N-16-040-ZYL-HA25-S	30393976

Versione in metallo duro

6	7,8	10	110	70	CFS201N-06-070-ZYL-HA10-H	30393779
8	9,8	16	110	60	CFS201N-08-060-ZYL-HA16-H	30393790
10	11,8	20	110	60	CFS201N-10-060-ZYL-HA20-H	30393801
10	11,8	20	150	100	CFS201N-10-100-ZYL-HA20-H	30393802
12	15,8	20	130	80	CFS201N-12-080-ZYL-HA20-H	30393966
12	15,8	20	150	100	CFS201N-12-100-ZYL-HA20-H	30393967
16	19,8	25	150	94	CFS201N-16-094-ZYL-HA25-H	30393979

Parametri di lavorazione consigliati per punte pilota

Avanzamento e velocità di taglio

CPD-Spot-Drill | CPD100

GTM*	Materiale	Resistenza/ durezza [N/mm ²] [HRC]	Raffreddamento			v _c [m/min]	f _z [mm]					
			MQL/Aria	A secco	KSS		Diametro punta [mm]					
							8,00	10,00	12,00	16,00	20,00	
P	P1	P1.1 Acciai da costruzione, automatici, da cementazione e da bonifica, non legati	< 700	✓	✓	✓	160	0,084	0,100	0,115	0,141	0,161
		P1.2 Acciai da costruzione, automatici, da cementazione e da bonifica, non legati	< 1.200	✓	✓	✓	130	0,078	0,094	0,108	0,131	0,150
	P2	P2.1 Acciai da nitrurazione, da cementazione e da bonifica, legati	< 900	✓	✓	✓	145	0,084	0,100	0,115	0,141	0,161
		P2.2 Acciai da nitrurazione, da cementazione e da bonifica, legati	< 1.400	✓		✓	100	0,070	0,084	0,096	0,117	0,134
	P3	P3.1 Acciai per utensili, per cuscinetti volventi, armonici e per lavorazioni veloci**	< 800	✓	✓	✓	95	0,081	0,097	0,111	0,136	0,156
		P3.2 Acciai per utensili, per cuscinetti volventi, armonici e per lavorazioni veloci**	< 1.000	✓		✓	85	0,077	0,092	0,106	0,129	0,148
		P3.3 Acciai per utensili, per cuscinetti volventi, armonici e per lavorazioni veloci**	< 1.500	✓		✓	80	0,073	0,087	0,100	0,122	0,140
	P4	P4.1 Acciai inossidabili, ferritici e martensitici		✓		✓	65	0,056	0,067	0,077	0,094	0,107
	P5	P5.1 Acciaio fuso				✓	95	0,081	0,097	0,111	0,136	0,156
	P6	P6.1 Acciaio fuso, ferritico e martensitico				✓	65	0,039	0,047	0,054	0,066	0,075
M	M1	M1.1 Acciai inossidabili, austenitici	< 700	✓		✓	45	0,049	0,059	0,067	0,082	0,094
		M1.2 Acciai inossidabili, ferritici/austenitici (Duplex)	< 1.000			✓	40	0,040	0,048	0,056	0,068	0,078
	M2	M2.1 Acciaio fuso inossidabile, austenitico	< 700	✓		✓	50	0,053	0,064	0,073	0,089	0,102
	M3	M3.1 Acciaio fuso inossidabile, ferritico/austenitico (Duplex)	< 1.000			✓	45	0,042	0,050	0,058	0,070	0,081
K	K1	K1.1 Ghisa con grafite lamellare (ghisa grigia), GJL	< 300	✓	✓	✓	175	0,140	0,167	0,192	0,235	0,268
		K2.1 Ghisa con grafite sferoidale, GJS	< 500	✓	✓	✓	160	0,119	0,142	0,163	0,199	0,228
	K2	K2.2 Ghisa con grafite sferoidale, GJS	500-800	✓	✓	✓	130	0,098	0,117	0,134	0,164	0,188
		K2.3 Ghisa con grafite sferoidale, GJS	> 800	✓	✓	✓	70	0,056	0,067	0,077	0,094	0,107
	K3	K3.1 Ghisa con grafite vermicolare, GJV; acciaio fuso malleabile, GJM	< 500	✓	✓	✓	115	0,098	0,117	0,134	0,164	0,188
		K3.2 Ghisa con grafite vermicolare, GJV; acciaio fuso malleabile, GJM	> 500	✓	✓	✓	110	0,084	0,100	0,115	0,141	0,161
N	N1	N1.1 Alluminio, non legato e legato < 3% Si		✓	✓	✓	610	0,142	0,170	0,196	0,239	0,273
		N1.2 Alluminio, legato <= 7% Si		✓	✓	✓	405	0,149	0,179	0,206	0,251	0,287
		N1.3 Alluminio, legato > 7-12% Si		✓	✓	✓	325	0,156	0,187	0,215	0,263	0,301
		N1.4 Alluminio, legato > 12% Si		✓	✓	✓	235	0,171	0,204	0,235	0,287	0,328
	N2	N2.1 Rame, non legato e bassolegato	< 300	✓	✓	✓	235	0,114	0,136	0,157	0,191	0,219
		N2.2 Rame, legato	> 300	✓	✓	✓	175	0,114	0,136	0,157	0,191	0,219
		N2.3 Ottone, bronzo, ghisa rossa	< 1.200	✓	✓	✓	295	0,071	0,085	0,098	0,120	0,137

* Gruppi di materiale MAPAL

** Qualora la somma dei componenti di lega Cr, Mo, Ni, V, W equivalesse a > 8%, selezionare il gruppo di materiale MAPAL immediatamente superiore.

I valori di lavoro indicati sono valori orientativi.

I dati ottimali per la specifica applicazione devono essere rilevati eseguendo diversi tentativi o durante l'effettiva lavorazione.

Parametri di lavorazione consigliati per punte pilota

Avanzamento e velocità di taglio

Tritan-Spot-Drill-Steel | SCD670

GTM*		Materiale	Resistenza/durezza [N/mm ²] [HRC]	
P	P1	P1.1 Acciai da costruzione, automatici, da cementazione e da bonifica, non legati	< 700	
		P1.2 Acciai da costruzione, automatici, da cementazione e da bonifica, non legati	< 1.200	
	P2	P2.1 Acciai da niturazione, da cementazione e da bonifica, legati	< 900	
		P2.2 Acciai da niturazione, da cementazione e da bonifica, legati	< 1.400	
	P3	P3.1 Acciai per utensili, per cuscinetti volventi, armonici e per lavorazioni veloci**	< 800	
		P3.2 Acciai per utensili, per cuscinetti volventi, armonici e per lavorazioni veloci**	< 1.000	
		P3.3 Acciai per utensili, per cuscinetti volventi, armonici e per lavorazioni veloci**	< 1.500	
	P5	P5.1 Acciaio fuso		
M	M1	M1.1 Acciai inossidabili, austenitici	< 700	
		M1.2 Acciai inossidabili, ferritici/austenitici (Duplex)	< 1.000	
	M2	M2.1 Acciaio fuso inossidabile, austenitico	< 700	
	M3	M3.1 Acciaio fuso inossidabile, ferritico/austenitico (Duplex)	< 1.000	
K	K1	K1.1 Ghisa con grafite lamellare (ghisa grigia), GJL	< 300	
		K2.1 Ghisa con grafite sferoidale, GJS	< 500	
		K2.2 Ghisa con grafite sferoidale, GJS	≤ 800	
	K2	K2.3 Ghisa con grafite sferoidale, GJS	> 800	
		K3	K3.1 Ghisa con grafite vermicolare, GJV; acciaio fuso malleabile, GJM	< 500
			K3.2 Ghisa con grafite vermicolare, GJV; acciaio fuso malleabile, GJM	> 500
N	N1	N1.1 Alluminio, non legato e legato < 3% Si		
		N1.2 Alluminio, legato ≤ 7% Si		
		N1.3 Alluminio, legato > 7-12% Si		
		N1.4 Alluminio, legato > 12% Si		
	N2	N2.1 Rame, non legato e bassolegato	< 300	
		N2.2 Rame, legato	> 300	
		N2.3 Ottone, bronzo, ghisa rossa	< 1.200	
	N4	N4.1 Plastica, thermoplast		
		N4.2 Plastica, duroplast		
		N4.3 Plastica, materiali espansi		
S	S1	S1.1 Titanio, leghe di titanio	< 400	
		S2.1 Titanio, leghe di titanio	< 1.200	
	S2	S2.2 Titanio, leghe di titanio	> 1.200	
		S3	S3.1 Nichel, non legato e legato	< 900
	S3.2 Nichel, non legato e legato		> 900	
	S4	S4.1 Superlega resistente ad alte temperature a base di Ni, Co e Fe		
	S5	S5.1 Leghe di tungsteno e molibdeno		
H	H1	H1.1 Acciaio temprato/acciaio fuso	< 44	
		H1.2 Acciaio temprato/acciaio fuso	< 55	

* Gruppi di materiale MAPAL

** Qualora la somma dei componenti di lega Cr, Mo, Ni, V, W equivalesse a > 8%, selezionare il gruppo di materiale MAPAL immediatamente superiore.

	Velocità di taglio v_c [m/min]				Avanzamento f [mm] con diametro punta					
	Adduzione interna del refrigerante	Raffreddamento esterno	MQL	Aria	4,00	5,50	7,50	10,50	14,50	20,00
	175	160	160		0,09	0,10	0,11	0,13	0,14	0,15
	160	130	130		0,11	0,12	0,14	0,16	0,17	0,18
	170	145	145		0,10	0,12	0,13	0,15	0,16	0,17
	120	100	100		0,08	0,09	0,11	0,12	0,13	0,14
	110	95	95		0,09	0,11	0,12	0,13	0,15	0,16
	90	85	85		0,08	0,09	0,10	0,11	0,12	0,13
	90	70	75		0,06	0,07	0,08	0,08	0,09	0,10
	110	95	95		0,10	0,12	0,13	0,15	0,16	0,17
	70	45	45		0,06	0,07	0,08	0,09	0,10	0,10
	75	50	50		0,06	0,07	0,08	0,09	0,10	0,10
	245	175	175	175	0,17	0,19	0,22	0,25	0,27	0,30
	225	140	170	170	0,16	0,18	0,20	0,23	0,25	0,27
	170	130	130		0,14	0,15	0,18	0,20	0,22	0,23
	100	70	85		0,09	0,10	0,12	0,13	0,14	0,15
	155	135	135		0,15	0,17	0,19	0,21	0,23	0,25
	135	120	120		0,12	0,13	0,15	0,17	0,19	0,20
	300	200	250		0,11	0,12	0,13	0,15	0,17	0,18
	250	180	200		0,14	0,15	0,18	0,20	0,22	0,23
	220	150	180		0,14	0,15	0,18	0,20	0,22	0,23
	180	120	150		0,14	0,15	0,18	0,20	0,22	0,23
	140	100			0,11	0,12	0,13	0,15	0,17	0,18
	120	90			0,14	0,15	0,18	0,20	0,22	0,23
	200	160	160	120	0,17	0,19	0,22	0,25	0,27	0,30
		60		50	0,09	0,10	0,12	0,13	0,14	0,15
		65		40	0,07	0,08	0,09	0,11	0,12	0,12
				400	0,07	0,08	0,09	0,11	0,12	0,12
	40	25			0,062	0,069	0,078	0,088	0,097	0,104
	30	20			0,053	0,059	0,067	0,075	0,083	0,089
	25	15			0,044	0,050	0,056	0,063	0,069	0,074
	20	15			0,035	0,040	0,045	0,050	0,055	0,059
	15	10			0,044	0,050	0,056	0,063	0,069	0,074
	15	10			0,035	0,040	0,045	0,050	0,055	0,059
	15	10			0,035	0,040	0,045	0,050	0,055	0,059
	80	80	80		0,078	0,087	0,098	0,109	0,120	0,128
	30	30	30		0,053	0,059	0,067	0,075	0,083	0,089

I parametri di lavorazione indicati sono valori orientativi.

I dati ottimali per la specifica applicazione devono essere rilevati eseguendo diversi tentativi o durante l'effettiva lavorazione.

Parametri di lavorazione consigliati per punte pilota

Avanzamento e velocità di taglio

ECU-Centre-Drill | SCD450

GTM*		Materiale	Resistenza/durezza [N/mm ²] [HRC]
P	P1	P1.1 Acciai da costruzione, automatici, da cementazione e da bonifica, non legati	< 700
		P1.2 Acciai da costruzione, automatici, da cementazione e da bonifica, non legati	< 1.200
	P2	P2.1 Acciai da nitrurazione, da cementazione e da bonifica, legati	< 900
		P2.2 Acciai da nitrurazione, da cementazione e da bonifica, legati	< 1.400
	P3	P3.1 Acciai per utensili, per cuscinetti volventi, armonici e per lavorazioni veloci**	< 800
		P3.2 Acciai per utensili, per cuscinetti volventi, armonici e per lavorazioni veloci**	< 1.000
		P3.3 Acciai per utensili, per cuscinetti volventi, armonici e per lavorazioni veloci**	< 1.500
	P4	P4.1 Acciai inossidabili, ferritici e martensitici	
	P5	P5.1 Acciaio fuso	
	P6	P6.1 Acciaio fuso, ferritico e martensitico	
M	M1	M1.1 Acciai inossidabili, austenitici	< 700
		M1.2 Acciai inossidabili, ferritici/austenitici (Duplex)	< 1.000
	M2	M2.1 Acciaio fuso inossidabile, austenitico	< 700
	M3	M3.1 Acciaio fuso inossidabile, ferritico/austenitico (Duplex)	< 1.000
N	N2	N2.1 Rame, non legato e bassolegato	< 300
		N2.2 Rame, legato	> 300
		N2.3 Ottone, bronzo, ghisa rossa	< 1.200
S	S1	S1.1 Titanio, leghe di titanio	< 400
		S2.1 Titanio, leghe di titanio	< 1.200
	S2	S2.2 Titanio, leghe di titanio	> 1.200
		S3.1 Nichel, non legato e legato	< 900
	S3	S3.2 Nichel, non legato e legato	> 900
		S4	S4.1 Superlega resistente ad alte temperature a base di Ni, Co e Fe
S5	S5.1 Leghe di tungsteno e molibdeno		

* Gruppi di materiale MAPAL

** Qualora la somma dei componenti di lega Cr, Mo, Ni, V, W equivallesse a > 8%, selezionare il gruppo di materiale MAPAL immediatamente superiore.

	Velocità di taglio v_c [m/min]				Avanzamento f [mm] con diametro punta					
	Adduzione interna del refrigerante	Raffreddamento esterno	MQL	Aria	0,50	0,83	1,38	2,29	3,80	6,30
		70	70		0,01	0,01	0,02	0,02	0,03	0,04
		55	55		0,01	0,02	0,02	0,03	0,04	0,06
		65	65		0,01	0,01	0,02	0,03	0,04	0,05
		45	45		0,01	0,01	0,02	0,02	0,03	0,04
		50	50		0,01	0,01	0,02	0,02	0,03	0,05
		40	40		0,01	0,01	0,02	0,02	0,03	0,04
		35	40		0,01	0,01	0,01	0,02	0,02	0,03
		35	40		0,01	0,01	0,01	0,02	0,02	0,03
		65	65		0,01	0,01	0,02	0,03	0,04	0,05
		35	40		0,01	0,01	0,01	0,02	0,02	0,03
		30	30		0,01	0,01	0,01	0,02	0,02	0,03
		25	25		0,01	0,01	0,01	0,01	0,02	0,03
		30	30		0,01	0,01	0,01	0,02	0,02	0,03
		25	25		0,01	0,01	0,01	0,01	0,02	0,03
		85			0,01	0,01	0,02	0,02	0,03	0,04
		75			0,01	0,01	0,02	0,03	0,04	0,06
		135	135		0,01	0,01	0,02	0,03	0,04	0,07
		40	40		0,01	0,01	0,02	0,02	0,03	0,04
		35	35		0,01	0,01	0,02	0,02	0,03	0,04
		30	30		0,01	0,01	0,02	0,02	0,03	0,04
		25	25		0,01	0,01	0,02	0,02	0,03	0,04
		20	20		0,01	0,01	0,02	0,02	0,03	0,04
		20	20		0,01	0,01	0,02	0,02	0,03	0,04
		20	20		0,01	0,01	0,02	0,02	0,03	0,04

I parametri di lavorazione indicati sono valori orientativi.

I dati ottimali per la specifica applicazione devono essere rilevati eseguendo diversi tentativi o durante l'effettiva lavorazione.



FORATURA A GRADINO

Punta a gradino

Tritan-Step-Drill-Steel 258

MEGA-Step-Drill-Steel-Plus 259

Allegato tecnico

Parametri di lavorazione consigliati 262

Tritan-Step-Drill-Steel

Punte a gradino in metallo duro integrale
SCD561, adduzione interna del refrigerante

Versione:

Diametro punta: 3,98 – 17,50 mm
Tolleranza di foratura: IT 9 (raggiungibile)
Materiale da taglio: HP835
Numero di taglienti: 3
Numero margini di guida: 3
Angolo tra taglienti: 145°
Angolo dell'elica: 30°

Applicazione

per fori da maschiare con svasatura a 90°.

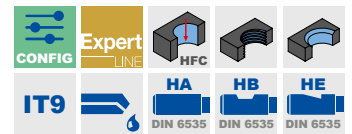
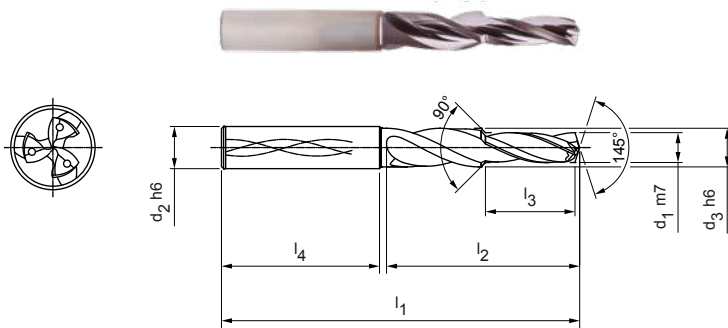

Serie selezionata per il magazzino con forma del codolo HA

Per filettatura	Dimensioni							Forma del codolo HA	
	d ₁ m7	d ₂ h6	d ₃ h6	l ₁	l ₂	l ₃	l ₄	Specifiche	Codice
M5	4,25	6	5,5	66	28	13,6	36	SCD561-0425-3-3-145HA-HP835	31053657
M6	5,10	8	6,6	79	41	16,5	36	SCD561-0510-3-3-145HA-HP835	31053658
M8	6,85	10	8,8	89	47	21	40	SCD561-0685-3-3-145HA-HP835	31053659
M8x1	7,10	10	8,8	89	47	21	40	SCD561-0710-3-3-145HA-HP835	31073436
M10	8,60	12	11	102	55	25,5	45	SCD561-0860-3-3-145HA-HP835	31053670
M10x1	9,10	12	11	102	55	25,5	45	SCD561-0910-3-3-145HA-HP835	31073438
M12	10,35	14	13,2	107	60	30	45	SCD561-1035-3-3-145HA-HP835	31053671
M16	14,15	18	17,6	123	73	38,5	48	SCD561-1415-3-3-145HA-HP835	31053672

Caratteristiche configurabili



Diametro:

Diametro a libera scelta a passi da 0,01 mm



Lunghezza gradino:

Lunghezza gradino a libera scelta a passi da 0,01 mm



Forma del codolo:

Forma del codolo: HB | HE

Specifiche:

SCD561-[diametro]-3-3-145[forma del codolo]-HP835

Esempio:

SCD561-0431-3-3-145HE-HP835

Forma del codolo HE

Diametro utensile d₁ = 4,31 mm

Dimensioni serie configurabile

d ₁ min.	d ₁ max.	d ₂ h6	d ₃ h6	l ₁	l ₂	l ₃ min.	l ₃ max.
3,98	4,50	6	5	66	28	4,00	15,4
4,51	5,50	6	6	66	28	4,50	15,4
5,51	6,50	8	7	79	41	5,50	22,55
6,51	7,50	8	8	79	41	6,50	22,55
7,51	8,50	10	9	89	47	7,50	25,85
8,51	9,50	10	10	89	47	8,50	25,85
9,51	11,50	12	12	102	55	9,50	30,25
11,51	13,50	14	14	107	60	11,50	33
13,51	15,50	16	16	115	65	13,50	35,75
15,51	17,50	18	18	123	73	15,50	40,15

Fori da maschiare con smusso a 90°

secondo DIN 8378 con Tritan-Step-Drill-Steel



Misure in mm.

Per i parametri di lavorazione consigliati, vedere la fine del capitolo.

Versioni speciali e altri rivestimenti disponibili su richiesta.

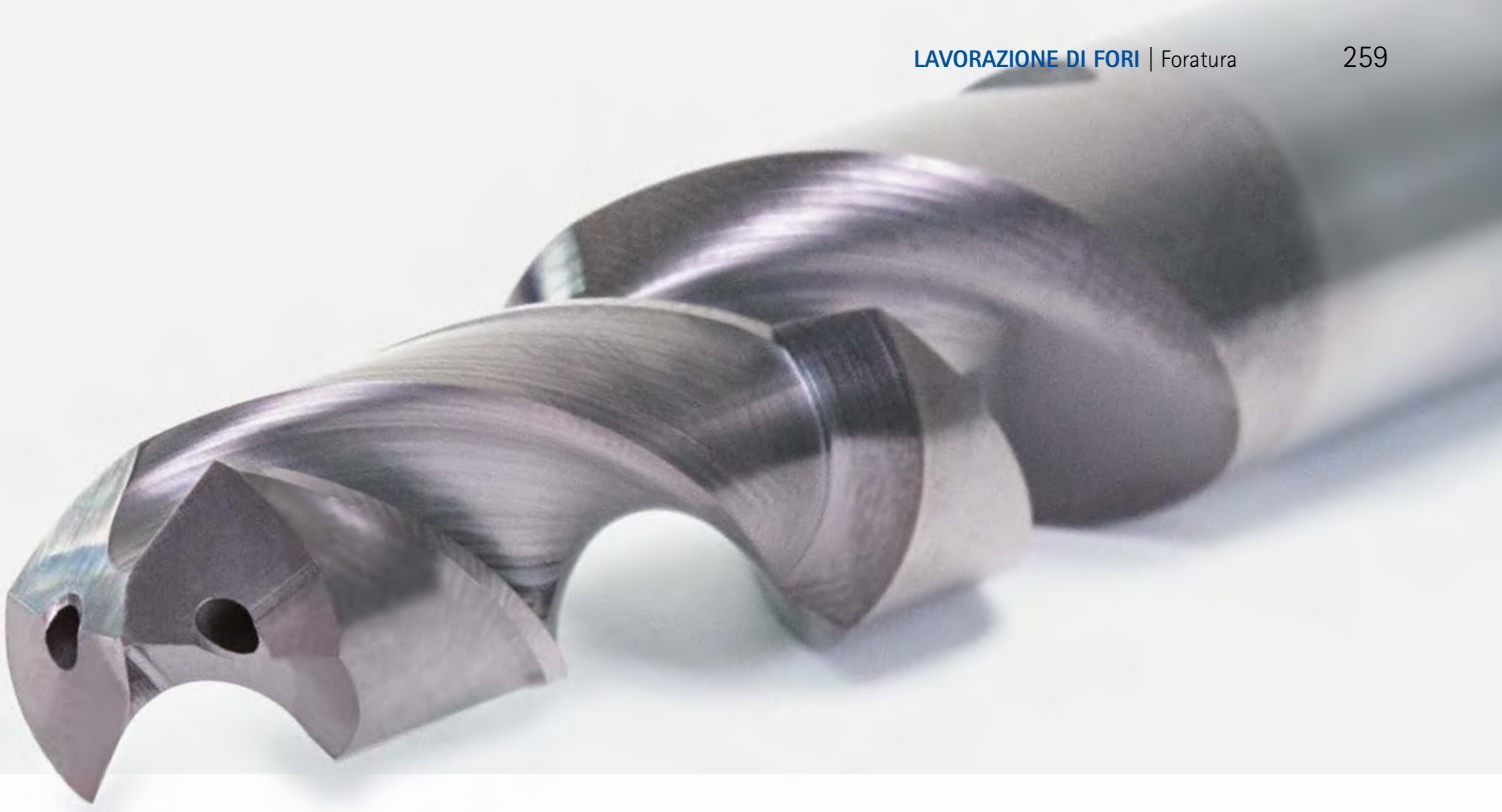

MEGA-STEP-DRILL-STEEL-PLUS

Lavorazione conveniente di fori da maschiare (secondo DIN 8378)

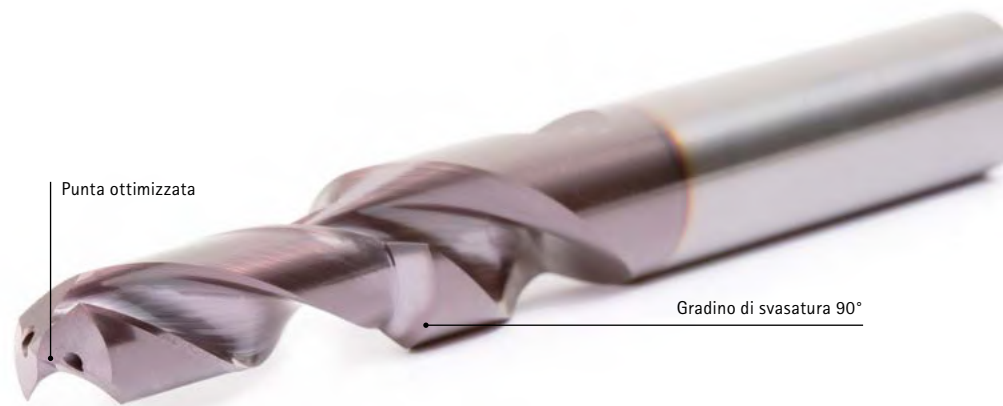
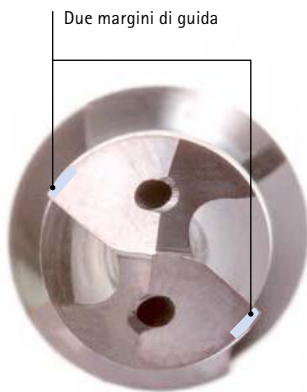

Foro da maschiare M10

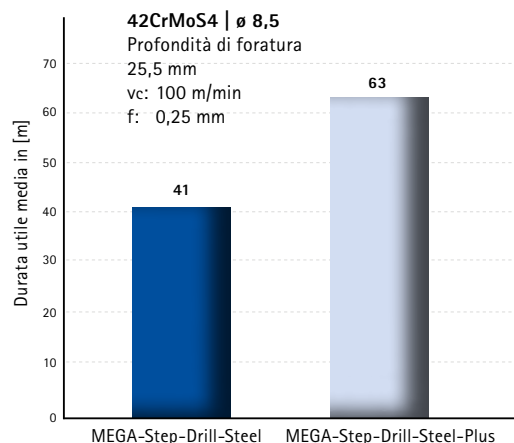
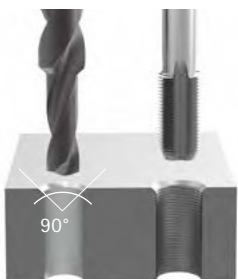

IN SINTESI

- Upgrade di MEGA-Step-Drill-Steel con e senza addizione interna del refrigerante
- Innovativo rivestimento
- Micro e macro geometria ottimizzate
- Range di diametro da 2,50 a 15,00 mm

VANTAGGI

- Velocità di taglio maggiore del 15%*
- Avanzamento maggiore del 15%
- Durata superiore del 50%*

* Rispetto al modello precedente

MEGA-Step-Drill-Steel-Plus

Punte a gradino in metallo duro integrale

SCD590, adduzione esterna di refrigerante, prodotto successivo a MEGA-Step-Drill-Steel

Versione:

Diametro punta: 2,50 – 14,00 mm
 Materiale da taglio: HP358
 Numero di taglienti: 2
 Numero margini di guida: 2
 Angolo tra taglienti: 140°
 Angolo dell'elica: 30°

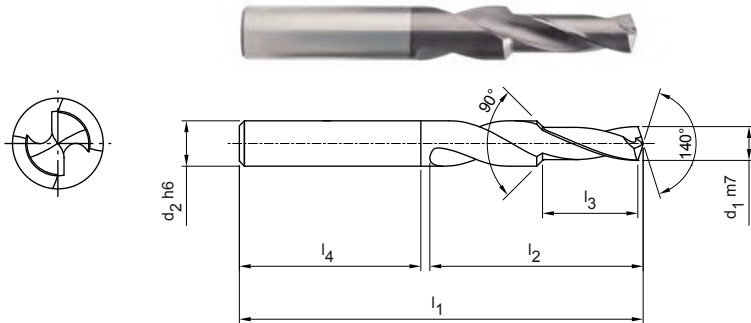

Serie selezionata per il magazzino con forma del codolo HA

		Dimensioni						Forma del codolo HA	
Per filettatura	Tipo	d ₁ m7	d ₂ h6	l ₁	l ₂	l ₃	l ₄	Specifiche	Codice
M3	GB	2,50	6	62	20	8,8	36	SCD590-0250-2-2-140HA-HP358	31228957
M3	F0	2,80	6	62	20	8,8	36	SCD590-0280-2-2-140HA-HP358	31228958
M4	GB	3,30	6	62	24	11,4	36	SCD590-0330-2-2-140HA-HP358	31228959
M4	F0	3,70	6	62	24	11,4	36	SCD590-0370-2-2-140HA-HP358	31228960
M5	GB	4,20	6	66	28	13,6	36	SCD590-0420-2-2-140HA-HP358	31228961
M5	F0	4,65	6	66	28	13,6	36	SCD590-0465-2-2-140HA-HP358	31228962
M6	GB	5,00	8	79	34	16,5	36	SCD590-0500-2-2-140HA-HP358	31149619
M6	F0	5,55	8	79	34	16,5	36	SCD590-0555-2-2-140HA-HP358	31228963
M8	GB	6,80	10	89	47	21	40	SCD590-0680-2-2-140HA-HP358	31141315
M8	F0	7,45	10	89	47	21	40	SCD590-0745-2-2-140HA-HP358	31228964
M10	GB	8,50	12	102	55	25,5	45	SCD590-0850-2-2-140HA-HP358	31228965
M10	F0	9,30	12	102	55	25,5	45	SCD590-0930-2-2-140HA-HP358	31228966
M12	GB	10,20	14	107	60	30	45	SCD590-1020-2-2-140HA-HP358	31228967
M12	F0	11,20	14	107	60	30	45	SCD590-1120-2-2-140HA-HP358	31228968
M14	GB	12,00	16	115	65	34,5	48	SCD590-1200-2-2-140HA-HP358	31149650
M16	GB	14,00	18	123	73	38,5	48	SCD590-1400-2-2-140HA-HP358	31228970

GB: Preforo maschiatura | F0: Preforo maschiatura a rullare / maschiatura a deformazione

Caratteristiche configurabili

Forma del codolo:
 Forma del codolo: HB | HE

Specifiche:
 SCD590-0420-2-2-140[forma del codolo]-HP358

Esempio:

SCD590-0420-2-2-140HE05-HP358

Forma del codolo HE

Misure in mm.

Per i parametri di lavorazione consigliati, vedere la fine del capitolo.

Versioni speciali e altri rivestimenti disponibili su richiesta.

MEGA-Step-Drill-Steel-Plus

Punte a gradino in metallo duro integrale

SCD591, adduzione interna del refrigerante, prodotto successivo a MEGA-Step-Drill-Steel

Versione:

Diametro punta: 3,30 - 14,00 mm

Materiale da taglio: HP358

Numero di taglienti: 2

Numero margini di guida: 2

Angolo tra taglienti: 140°

Angolo dell'elica: 30°

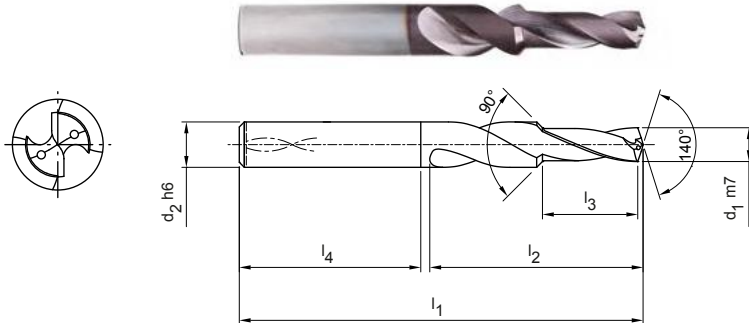

Serie selezionata per il magazzino con forma del codolo HA

Per filettatura	Tipo	Dimensioni						Forma del codolo HA	
		d ₁ m7	d ₂ h6	l ₁	l ₂	l ₃	l ₄	Specifiche	Codice
M4	GB	3,30	6	62	24	11,4	36	SCD591-0330-2-2-140HA-HP358	31140987
M4	F0	3,70	6	62	24	11,4	36	SCD591-0370-2-2-140HA-HP358	31140988
M5	GB	4,20	6	66	28	13,6	36	SCD591-0420-2-2-140HA-HP358	31140989
M6	GB	5,00	8	79	34	16,5	36	SCD591-0500-2-2-140HA-HP358	31140991
M6	F0	5,55	8	79	34	16,5	36	SCD591-0555-2-2-140HA-HP358	31140992
M8	GB	6,80	10	89	47	21	40	SCD591-0680-2-2-140HA-HP358	31140993
M8	F0	7,45	10	89	47	21	40	SCD591-0745-2-2-140HA-HP358	31140994
M10	GB	8,50	12	102	55	25,5	45	SCD591-0850-2-2-140HA-HP358	31140995
M10	F0	9,30	12	102	55	25,5	45	SCD591-0930-2-2-140HA-HP358	31140996
M12	GB	10,20	14	107	60	30	45	SCD591-1020-2-2-140HA-HP358	31140997
M12	GB	10,20	14	107	60	30	45	SCD591-1020-2-2-140HA-HP358	31140997

Disponibile su richiesta

M12	F0	11,20	14	107	60	30	45	SCD591-1120-2-2-140HA-HP358	31140998
M16	GB	14,00	18	123	73	38,5	48	SCD591-1400-2-2-140HA-HP358	31140999

GB: Preforo maschiatura | F0: Preforo maschiatura a rullare / maschiatura a deformazione

Caratteristiche configurabili



Forma del codolo:
Forma del codolo: HB | HE

Specifiche:
SCD591-0420-2-2-140[forma del codolo]-HP358

Esempio:

SCD591-0420-2-2-140HE05-HP358

Forma del codolo HE

Misure in mm.

Per i parametri di lavorazione consigliati, vedere la fine del capitolo.

Versioni speciali e altri rivestimenti disponibili su richiesta.

Parametri di lavorazione consigliati per punte a gradino

Avanzamento e velocità di taglio

Tritan-Step-Drill-Steel | SCD561

GTM*		Materiale	Resistenza/durezza [N/mm ²] [HRC]
P	P1	P1.1 Acciai da costruzione, automatici, da cementazione e da bonifica, non legati	< 700
		P1.2 Acciai da costruzione, automatici, da cementazione e da bonifica, non legati	< 1.200
	P2	P2.1 Acciai da nitrurazione, da cementazione e da bonifica, legati	< 900
		P2.2 Acciai da nitrurazione, da cementazione e da bonifica, legati	< 1.400
	P3	P3.1 Acciai per utensili, per cuscinetti volventi, armonici e per lavorazioni veloci**	< 800
		P3.2 Acciai per utensili, per cuscinetti volventi, armonici e per lavorazioni veloci**	< 1.000
		P3.3 Acciai per utensili, per cuscinetti volventi, armonici e per lavorazioni veloci**	< 1.500
	P5	P5.1 Acciaio fuso	
M	M1	M1.1 Acciai inossidabili, austenitici	< 700
		M1.2 Acciai inossidabili, ferritici/austenitici (Duplex)	< 1.000
K	K1	K1.1 Ghisa con grafite lamellare (ghisa grigia), GJL	< 300
		K2.1 Ghisa con grafite sferoidale, GJS	< 500
	K2	K2.2 Ghisa con grafite sferoidale, GJS	≤ 800
		K2.3 Ghisa con grafite sferoidale, GJS	> 800
	K3	K3.1 Ghisa con grafite vermicolare, GJV; acciaio fuso malleabile, GJM	< 500
		K3.2 Ghisa con grafite vermicolare, GJV; acciaio fuso malleabile, GJM	> 500

* Gruppi di materiale MAPAL

** Qualora la somma dei componenti di lega Cr, Mo, Ni, V, W equivalesse a > 8%, selezionare il gruppo di materiale MAPAL immediatamente superiore.

	Velocità di taglio v_c [m/min]				Avanzamento f [mm] con diametro punta					
	Adduzione interna del refrigerante	Raffreddamento esterno	MQL	Aria	4,00	5,50	7,50	10,50	14,50	20,00
	115	105	105		0,24	0,30	0,37	0,46	0,56	0,65
	105	85	85		0,30	0,37	0,46	0,58	0,70	0,81
	115	100	100		0,28	0,35	0,44	0,55	0,66	0,77
	80	70	70		0,24	0,29	0,36	0,44	0,53	0,61
	85	75	75		0,25	0,31	0,39	0,49	0,60	0,69
	70	65	65		0,21	0,26	0,33	0,41	0,49	0,56
	70	50	60		0,18	0,21	0,26	0,32	0,38	0,43
	115	100	100		0,28	0,35	0,44	0,55	0,66	0,77
	55	35	35		0,11	0,14	0,18	0,22	0,27	0,31
	140	100	100	100	0,36	0,45	0,55	0,67	0,80	0,91
	185	115	140	140	0,35	0,43	0,52	0,63	0,74	0,84
	115	85	85		0,31	0,38	0,46	0,55	0,64	0,73
	70	45	60		0,17	0,20	0,24	0,28	0,33	0,37
	105	90	90		0,34	0,41	0,49	0,59	0,69	0,78
	90	80	80		0,28	0,34	0,40	0,47	0,55	0,62

I parametri di lavorazione indicati sono valori orientativi.

I dati ottimali per la specifica applicazione devono essere rilevati eseguendo diversi tentativi o durante l'effettiva lavorazione.

Parametri di lavorazione consigliati per punte a gradino

Avanzamento e velocità di taglio

MEGA-Step-Drill-Steel-Plus | SCD590, 591

GTM*		Materiale	Resistenza/durezza [N/mm ²] [HRC]	
P	P1	P1.1 Acciai da costruzione, automatici, da cementazione e da bonifica, non legati	< 700	
		P1.2 Acciai da costruzione, automatici, da cementazione e da bonifica, non legati	< 1.200	
	P2	P2.1 Acciai da nitrurazione, da cementazione e da bonifica, legati	< 900	
		P2.2 Acciai da nitrurazione, da cementazione e da bonifica, legati	< 1.400	
	P3	P3.1 Acciai per utensili, per cuscinetti volventi, armonici e per lavorazioni veloci**	< 800	
		P3.2 Acciai per utensili, per cuscinetti volventi, armonici e per lavorazioni veloci**	< 1.000	
		P3.3 Acciai per utensili, per cuscinetti volventi, armonici e per lavorazioni veloci**	< 1.500	
	P4	P4.1 Acciai inossidabili, ferritici e martensitici		
	P5	P5.1 Acciaio fuso		
	P6	P6.1 Acciaio fuso, ferritico e martensitico		
	K	K1	K1.1 Ghisa con grafite lamellare (ghisa grigia), GJL	< 300
			K2.1 Ghisa con grafite sferoidale, GJS	< 500
K2		K2.2 Ghisa con grafite sferoidale, GJS	≤ 800	
		K2.3 Ghisa con grafite sferoidale, GJS	> 800	
K3		K3.1 Ghisa con grafite vermicolare, GJV; acciaio fuso malleabile, GJM	< 500	
		K3.2 Ghisa con grafite vermicolare, GJV; acciaio fuso malleabile, GJM	> 500	
H	H1	H1.1 Acciaio temprato/acciaio fuso	< 44	
		H1.2 Acciaio temprato/acciaio fuso	< 55	

* Gruppi di materiale MAPAL

** Qualora la somma dei componenti di lega Cr, Mo, Ni, V, W equivalesse a > 8%, selezionare il gruppo di materiale MAPAL immediatamente superiore.

	Velocità di taglio v_c [m/min]				Avanzamento f [mm] con diametro punta					
	Adduzione interna del refrigerante	Raffreddamento esterno	MQL	Aria	2,50	3,70	5,00	7,45	10,20	15,00
	110	100	100		0,09	0,11	0,14	0,18	0,23	0,29
	100	85	85		0,11	0,14	0,18	0,23	0,29	0,36
	110	95	95		0,10	0,13	0,17	0,22	0,27	0,34
	75	65	65		0,09	0,11	0,14	0,18	0,22	0,27
	85	70	70		0,09	0,11	0,15	0,19	0,25	0,30
	65	60	60		0,08	0,10	0,13	0,16	0,20	0,25
	65	50	55		0,07	0,08	0,10	0,13	0,16	0,19
	65	50	55		0,06	0,08	0,10	0,13	0,16	0,20
	110	95	95		0,10	0,13	0,17	0,22	0,27	0,34
	65	50	55		0,06	0,08	0,10	0,13	0,16	0,20
	120	85	85	85	0,13	0,19	0,26	0,35	0,45	0,54
	160	100	120	120	0,13	0,18	0,25	0,33	0,42	0,50
	100	75	75		0,12	0,16	0,22	0,28	0,36	0,43
	60	40	50		0,09	0,12	0,15	0,19	0,24	0,28
	90	80	80		0,13	0,18	0,23	0,31	0,39	0,46
	80	70	70		0,11	0,15	0,19	0,25	0,31	0,36
	90	90	90		0,08	0,10	0,13	0,16	0,20	0,25
	25	25	25		0,04	0,05	0,07	0,09	0,11	0,14

I parametri di lavorazione indicati sono valori orientativi.

I dati ottimali per la specifica applicazione devono essere rilevati eseguendo diversi tentativi o durante l'effettiva lavorazione.





FORATURA PROFONDA

Punta per foratura profonda

MEGA-Pilot-Drill	268
MEGA-Deep-Drill	269
MEGA-Deep-Drill-Alu	278

Allegato tecnico

Parametri di lavorazione consigliati	284
Indicazioni per l'applicazione delle punte per foratura profonda	742

MEGA-Pilot-Drill

Punte a gradino in metallo duro integrale
SCD581, adduzione interna del refrigerante

Versione:

Diametro punta: 1,00 – 3,00 mm
Tolleranza di foratura: IT 9 (raggiungibile)
Materiale da taglio: HP246
Numero di taglienti: 2
Numero margini di guida: 2
Angolo tra taglienti: 142°

Applicazione

Punta pilota specifica per MEGA-Deep-Drill.
Utilizzabile al massimo fino a diametro 3,00 mm.

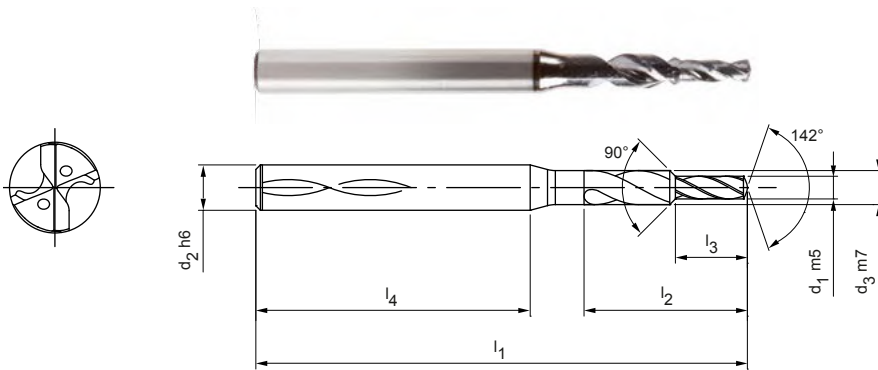

Serie selezionata per il magazzino con forma del codolo HA

Dimensioni							Forma del codolo HA	
d ₁ m5	d ₂ h6	d ₃ m7	l ₁	l ₂	l ₃	l ₄	Specifiche	Codice
1,00	3	1,5	50	7,2	3	38	SCD581-0100-2-2-142HA-HP246	31080870
1,10	3	1,65	50	7,9	3,3	37,5	SCD581-0110-2-2-142HA-HP246	31080871
1,20	3	1,8	50	8,6	3,6	36,9	SCD581-0120-2-2-142HA-HP246	31080872
1,30	3	1,95	50	9,4	3,9	36,3	SCD581-0130-2-2-142HA-HP246	31080873
1,40	3	2,1	50	10,1	4,2	35,7	SCD581-0140-2-2-142HA-HP246	31080874
1,50	3	2,25	50	10,8	4,5	35,1	SCD581-0150-2-2-142HA-HP246	31080875
1,60	3	2,4	50	11,5	4,8	34,6	SCD581-0160-2-2-142HA-HP246	31080876
1,70	3	2,55	50	12,2	5,1	34	SCD581-0170-2-2-142HA-HP246	31080877
1,80	3	2,7	50	13	5,4	33,4	SCD581-0180-2-2-142HA-HP246	31080878
1,90	4	2,85	55	13,7	5,7	35,9	SCD581-0190-2-2-142HA-HP246	31080879
2,00	4	3	55	14,4	6	35,3	SCD581-0200-2-2-142HA-HP246	31080880
2,10	4	3,15	55	15,1	6,3	34,8	SCD581-0210-2-2-142HA-HP246	31080881
2,20	4	3,3	55	15,8	6,6	34,2	SCD581-0220-2-2-142HA-HP246	31080882
2,30	4	3,45	55	16,6	6,9	33,6	SCD581-0230-2-2-142HA-HP246	31080883
2,40	4	3,6	55	17,3	7,2	33	SCD581-0240-2-2-142HA-HP246	31080884
2,50	4	3,75	55	18	7,5	32,4	SCD581-0250-2-2-142HA-HP246	31080885
2,60	6	3,9	66	18,7	7,8	39,1	SCD581-0260-2-2-142HA-HP246	31080886
2,70	6	4,05	66	19,4	8,1	38,5	SCD581-0270-2-2-142HA-HP246	31080887
2,80	6	4,2	66	20,2	8,4	37,9	SCD581-0280-2-2-142HA-HP246	31080888
2,90	6	4,35	66	20,9	8,7	37,4	SCD581-0290-2-2-142HA-HP246	31080889
3,00	6	4,5	66	21,6	9	36,8	SCD581-0300-2-2-142HA-HP246	31080890

Misure in mm.

Per i parametri di lavorazione consigliati, vedere la fine del capitolo.

Versioni speciali e altri rivestimenti disponibili su richiesta.

MEGA-Deep-Drill

Punta elicoidale in metallo duro integrale
SCD171 (20xD), adduzione interna del refrigerante

Versione:
 Diametro punta: 1,00 – 2,99 mm
 Tolleranza di foratura: \geq IT 9
 Materiale da taglio: HP246
 Numero di taglienti: 2
 Numero margini di guida: 4
 Angolo tra taglienti: 135°
 Angolo dell'elica: 30°
 Particolarità: Rivestimento testina

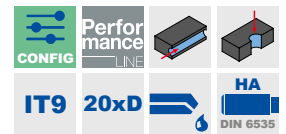
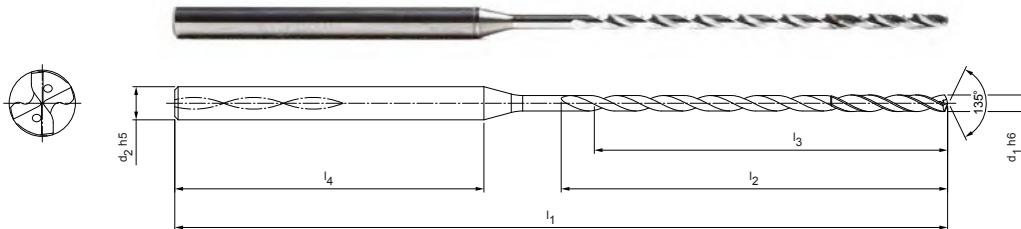

Serie selezionata per il magazzino con forma del codolo HA

Dimensioni						Rapporto L/d	Forma del codolo HA	
d ₁ h6	d ₂ h5	l ₁	l ₂	l ₃	l ₄		Specifiche	Codice
1,00	3	62	27	25	28	28	SCD171-0100-2-4-135HA20-HP246	30998795
1,10	3	62	27	25	28	28	SCD171-0110-2-4-135HA20-HP246	30998796
1,20	3	62	27	25	28	28	SCD171-0120-2-4-135HA20-HP246	30998798
1,30	3	70	35	33	28	28	SCD171-0130-2-4-135HA20-HP246	30998799
1,40	3	70	35	32	28	28	SCD171-0140-2-4-135HA20-HP246	30998800
1,50	3	70	35	32	28	28	SCD171-0150-2-4-135HA20-HP246	30998801
1,60	3	75	41	38	28	28	SCD171-0160-2-4-135HA20-HP246	30998802
1,70	3	75	41	38	28	28	SCD171-0170-2-4-135HA20-HP246	30998803
1,80	3	75	41	38	28	28	SCD171-0180-2-4-135HA20-HP246	30998804
1,90	3	80	46	43	28	28	SCD171-0190-2-4-135HA20-HP246	30998805
2,00	3	80	46	43	28	28	SCD171-0200-2-4-135HA20-HP246	30998806
2,10	3	80	46	42	28	28	SCD171-0210-2-4-135HA20-HP246	30998807
2,20	3	90	55	51	28	28	SCD171-0220-2-4-135HA20-HP246	30998808
2,30	3	90	55	51	28	28	SCD171-0230-2-4-135HA20-HP246	30998809
2,40	3	90	55	51	28	28	SCD171-0240-2-4-135HA20-HP246	30998810
2,50	3	90	55	51	28	28	SCD171-0250-2-4-135HA20-HP246	30998811
2,60	3	100	66	62	28	28	SCD171-0260-2-4-135HA20-HP246	30998812
2,70	3	100	66	61	28	28	SCD171-0270-2-4-135HA20-HP246	30998813
2,80	3	100	66	61	28	28	SCD171-0280-2-4-135HA20-HP246	30998814
2,90	3	100	66	61	28	28	SCD171-0290-2-4-135HA20-HP246	30998815

Prosegue alla pagina seguente.

Raccomandazione per punta pilota

Come punta pilota si raccomanda di utilizzare MEGA-Pilot-Drill (SCD581) oppure MI-CRO-Drill-Steel (SCD371 -5xD) con lo stesso diametro nominale.

L'angolo tra taglienti e le tolleranze del diametro sono concepiti per garantire un'ottima funzionalità, nonché una buona interazione tra la punta pilota e la punta per foratura profonda.

MEGA-Deep-Drill | Punta elicoidale in metallo duro integrale SCD171 (20xD), adduzione interna del refrigerante

Caratteristiche configurabili

**Diametro:**

Diametro a libera scelta a passi da 0,01 mm

**Specifiche:**

SCD171-[diametro]-2-4-135HA20-HP246

Esempio:

SCD171-0221-2-4-135HA20-HP246

Diametro utensile $d_1 = 2,21$ mm

Dimensioni serie configurabile

d_1 min.	d_1 max.	d_2 h6	l_1	l_2	l_3	l_4
1,00	1,29	3	62	27	25	28
1,30	1,39	3	70	35	33	28
1,40	1,59	3	70	35	32	28
1,60	1,89	3	75	41	38	28
1,90	2,09	3	80	46	43	28
2,10	2,19	3	80	46	42	28
2,20	2,59	3	90	55	51	28
2,60	2,69	3	100	66	62	28
2,70	2,99	3	100	66	61	28

Le indicazioni tecniche di applicazione per la foratura profonda sono riportate nel capitolo Allegato tecnico.

Misure in mm.

Per i parametri di lavorazione consigliati, vedere la fine del capitolo.

Versioni speciali e altri rivestimenti disponibili su richiesta.

MEGA-Deep-Drill

Punta elicoidale in metallo duro integrale
SCD171 (30xD), adduzione interna del refrigerante

Versione:

Diametro punta: 1,00 – 2,99 mm
Tolleranza di foratura: \geq IT 9
Materiale da taglio: HP246
Numero di taglienti: 2
Numero margini di guida: 4
Angolo tra taglienti: 135°
Angolo dell'elica: 30°
Particolarità: Rivestimento testina

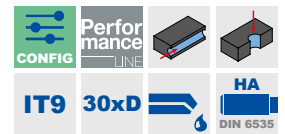
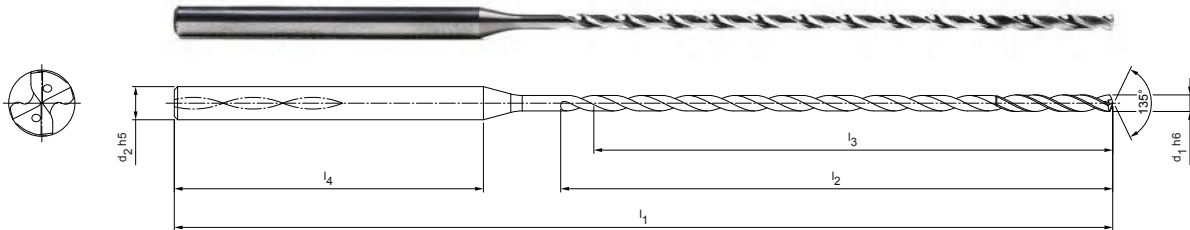
Serie selezionata per il magazzino con forma del codolo HA

Dimensioni						Rapporto L/d	Forma del codolo HA	
d ₁ h6	d ₂ h5	l ₁	l ₂	l ₃	l ₄		Specifiche	Codice
1,00	3	75	38	36	28	36	SCD171-0100-2-4-135HA30-HP246	30998816
1,10	3	75	38	36	28	33	SCD171-0110-2-4-135HA30-HP246	30998817
1,20	3	75	38	36	28	30	SCD171-0120-2-4-135HA30-HP246	30998818
1,30	3	85	50	48	28	37	SCD171-0130-2-4-135HA30-HP246	30998819
1,40	3	85	50	47	28	34	SCD171-0140-2-4-135HA30-HP246	30998820
1,50	3	85	50	47	28	31	SCD171-0150-2-4-135HA30-HP246	30998821
1,60	3	95	59	56	28	35	SCD171-0160-2-4-135HA30-HP246	30998822
1,70	3	95	59	56	28	33	SCD171-0170-2-4-135HA30-HP246	30998823
1,80	3	95	59	56	28	31	SCD171-0180-2-4-135HA30-HP246	30998824
1,90	3	100	66	63	28	33	SCD171-0190-2-4-135HA30-HP246	30998825
2,00	3	100	66	63	28	32	SCD171-0200-2-4-135HA30-HP246	30998826
2,10	3	100	66	62	28	30	SCD171-0210-2-4-135HA30-HP246	30998827
2,20	3	115	80	76	28	35	SCD171-0220-2-4-135HA30-HP246	30998828
2,30	3	115	80	76	28	33	SCD171-0230-2-4-135HA30-HP246	30998829
2,40	3	115	80	76	28	32	SCD171-0240-2-4-135HA30-HP246	30998830
2,50	3	115	80	76	28	30	SCD171-0250-2-4-135HA30-HP245	30451572
2,60	3	130	96	92	28	35	SCD171-0260-2-4-135HA30-HP246	30998832
2,70	3	130	96	91	28	34	SCD171-0270-2-4-135HA30-HP246	30998833
2,80	3	130	96	91	28	33	SCD171-0280-2-4-135HA30-HP246	30998834
2,90	3	130	96	91	28	31	SCD171-0290-2-4-135HA30-HP246	30998835

Prosegue alla pagina seguente.

Raccomandazione per punta pilota

Come punta pilota si raccomanda di utilizzare MEGA-Pilot-Drill (SCD581) oppure MI-CRO-Drill-Steel (SCD371 -5xD) con lo stesso diametro nominale.

L'angolo tra taglienti e le tolleranze del diametro sono concepiti per garantire un'ottima funzionalità, nonché una buona interazione tra la punta pilota e la punta per foratura profonda.

MEGA-Deep-Drill | Punta elicoidale in metallo duro integrale SCD171 (20xD), adduzione interna del refrigerante

Caratteristiche configurabili



Diametro:
Diametro a libera scelta a passi da
0,01 mm

**Specifiche:**

SCD171-[diametro]-2-4-135HA30-HP246

Esempio:

SCD171-0221-2-4-135HA30-HP246

Diametro utensile $d_1 = 2,21$ mm

Dimensioni serie configurabile

d_1 min.	d_1 max.	d_2 h6	l_1	l_2	l_3	l_4
1,00	1,29	3	75	38	36	28
1,30	1,39	3	85	50	48	28
1,40	1,59	3	85	50	47	28
1,60	1,89	3	95	59	56	28
1,90	2,09	3	100	66	63	28
2,10	2,19	3	100	66	62	28
2,20	2,59	3	115	80	76	28
2,60	2,69	3	130	96	92	28
2,70	2,99	3	130	96	91	28

Le indicazioni tecniche di applicazione per la foratura profonda sono riportate nel capitolo Allegato tecnico.

Misure in mm.

Per i parametri di lavorazione consigliati, vedere la fine del capitolo.

Versioni speciali e altri rivestimenti disponibili su richiesta.

MEGA-Deep-Drill

Punta elicoidale in metallo duro integrale
SCD171 (15xD), adduzione interna del refrigerante

Versione:
 Diametro punta: 3,00 - 15,00 mm
 Tolleranza di foratura: \geq IT 9
 Materiale da taglio: HP285 / HP245
 Numero di taglienti: 2
 Numero margini di guida: 4
 Angolo tra taglienti: 135°
 Angolo dell'elica: 30°

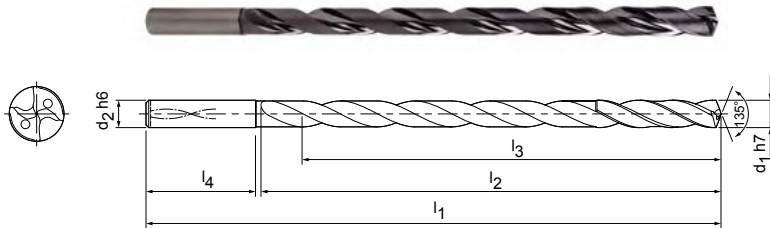

Serie selezionata per il magazzino con forma del codolo HA

Dimensioni						Rapporto L/d	Forma del codolo HA	
d ₁ h7	d ₂ h6	l ₁	l ₂	l ₃	l ₄		Specifiche	Codice
3,00	4	90	56	52	32	17	SCD171-0300-2-4-135HA15-HP285	30392214
3,50	4	100	66	61	32	17	SCD171-0350-2-4-135HA15-HP285	30392215
4,00	4	100	66	60	32	15	SCD171-0400-2-4-135HA15-HP285	30392216
4,50	5	110	74	67	34	15	SCD171-0450-2-4-135HA15-HP285	30392217
5,00	5	120	84	77	34	15	SCD171-0500-2-4-135HA15-HP285	30392218
5,50	6	130	92	84	36	15	SCD171-0550-2-4-135HA15-HP285	30392219
6,00	6	140	102	93	36	16	SCD171-0600-2-4-135HA15-HP285	30392220
7,00	7	155	115	105	38	15	SCD171-0700-2-4-135HA15-HP285	30392221
8,00	8	175	133	121	40	15	SCD171-0800-2-4-135HA15-HP285	30392222
9,00	9	190	148	135	40	15	SCD171-0900-2-4-135HA15-HP285	30392223
9,50	10	210	168	153	40	15	SCD171-0950-2-4-135HA15-HP245	30453021
10,00	10	210	168	153	40	15	SCD171-1000-2-4-135HA15-HP285	30392224
11,00	11	230	183	167	45	15	SCD171-1100-2-4-135HA15-HP245	30392225
12,00	12	250	203	185	45	15	SCD171-1200-2-4-135HA15-HP245	30392226
13,00	13	265	218	199	45	15	SCD171-1300-2-4-135HA15-HP245	30392227
14,00	14	285	233	212	50	15	SCD171-1400-2-4-135HA15-HP245	30392228
15,00	15	305	253	231	50	15	SCD171-1500-2-4-135HA15-HP245	30392229

Raccomandazione per punta pilota

Come punta pilota si raccomanda di utilizzare MEGA-Drill-Steel-Plus (SCD601 - 3xD) con lo stesso diametro nominale.

L'angolo tra taglienti e le tolleranze del diametro sono concepiti per garantire un'ottima funzionalità, nonché una buona interazione tra la punta pilota e la punta per foratura profonda.

Le indicazioni tecniche di applicazione per la foratura profonda sono riportate nel capitolo Allegato tecnico.

Misure in mm.

Per i parametri di lavorazione consigliati, vedere la fine del capitolo.

Versioni speciali e altri rivestimenti disponibili su richiesta.

MEGA-Deep-Drill

Punta elicoidale in metallo duro integrale
SCD171 (20xD), adduzione interna del refrigerante

Versione:

Diametro punta: 3,00 – 16,00 mm
Tolleranza di foratura: \geq IT 9
Materiale da taglio: HP245 / HP285
Numero di taglienti: 2
Numero margini di guida: 4
Angolo tra taglienti: 135°
Angolo dell'elica: 30°

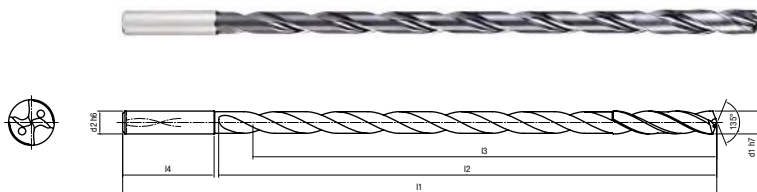
Serie selezionata per il magazzino con forma del codolo HA

Dimensioni						Rapporto L/d	Forma del codolo HA	
d ₁ h7	d ₂ h6	l ₁	l ₂	l ₃	l ₄		Specifiche	Codice
3,00	4	110	74	70	32	23	SCD171-0300-2-4-135HA20-HP285	30392231
3,50	4	120	86	81	32	23	SCD171-0350-2-4-135HA20-HP285	30392232
4,00	4	120	86	80	32	20	SCD171-0400-2-4-135HA20-HP285	30392233
5,00	5	145	109	102	34	20	SCD171-0500-2-4-135HA20-HP285	30392235
5,50	6	160	120	112	36	20	SCD171-0550-2-4-135HA20-HP285	30392236
6,00	6	170	130	121	36	20	SCD171-0600-2-4-135HA20-HP285	30392237
6,50	7	190	150	140	36	20	SCD171-0650-2-4-135HA20-HP245	30451508
7,00	7	190	150	140	38	20	SCD171-0700-2-4-135HA20-HP285	30392238
8,00	8	215	173	161	40	20	SCD171-0800-2-4-135HA20-HP285	30392239
9,00	9	240	196	183	40	20	SCD171-0900-2-4-135HA20-HP285	30392240
10,00	10	260	218	203	40	20	SCD171-1000-2-4-135HA20-HP285	30392241
11,00	11	285	238	222	45	20	SCD171-1100-2-4-135HA20-HP245	30392242
12,00	12	305	258	240	45	20	SCD171-1200-2-4-135HA20-HP245	30392243
14,00	14	355	303	282	50	20	SCD171-1400-2-4-135HA20-HP245	30392245
15,00	15	375	323	301	50	20	SCD171-1500-2-4-135HA20-HP245	30392246
16,00	16	400	348	324	50	20	SCD171-1600-2-4-135HA20-HP245	30392247

Raccomandazione per punta pilota

Come punta pilota si raccomanda di utilizzare MEGA-Drill-Steel-Plus (SCD601 - 3xD) con lo stesso diametro nominale.

L'angolo tra taglienti e le tolleranze del diametro sono concepiti per garantire un'ottima funzionalità, nonché una buona interazione tra la punta pilota e la punta per foratura profonda.

Le indicazioni tecniche di applicazione per la foratura profonda sono riportate nel capitolo Allegato tecnico.

Misure in mm.

Per i parametri di lavorazione consigliati, vedere la fine del capitolo.

Versioni speciali e altri rivestimenti disponibili su richiesta.

MEGA-Deep-Drill

Punta elicoidale in metallo duro integrale
SCD171 (25xD), adduzione interna del refrigerante

Versione:

Diametro punta:	3,00 – 14,00 mm
Tolleranza di foratura:	≥ IT 9
Materiale da taglio:	HP285 / HP245
Numero di taglienti:	2
Numero margini di guida:	4
Angolo tra taglienti:	135°
Angolo dell'elica:	30°

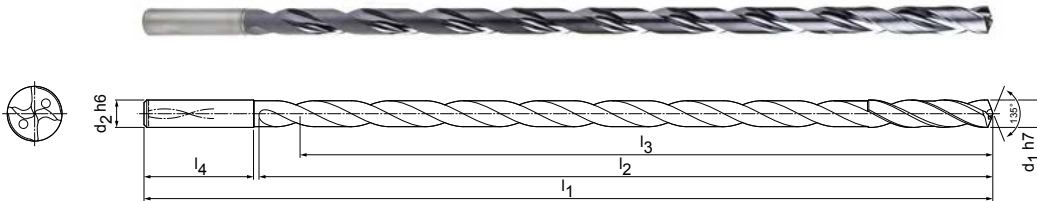

Serie selezionata per il magazzino con forma del codolo HA

Dimensioni						Rapporto L/d	Forma del codolo HA	
d ₁ h7	d ₂ h6	l ₁	l ₂	l ₃	l ₄		Specifiche	Codice
3,00	4	125	91	87	32	29	SCD171-0300-2-4-135HA25-HP285	30392248
3,50	4	140	106	101	32	29	SCD171-0350-2-4-135HA25-HP285	30392249
4,00	4	140	106	100	32	25	SCD171-0400-2-4-135HA25-HP285	30392250
5,00	5	170	134	127	34	25	SCD171-0500-2-4-135HA25-HP285	30392252
5,50	6	185	147	139	36	25	SCD171-0550-2-4-135HA25-HP285	30392253
6,00	6	200	160	151	36	25	SCD171-0600-2-4-135HA25-HP285	30392254
7,00	7	225	185	175	38	25	SCD171-0700-2-4-135HA25-HP285	30392255
8,00	8	255	213	201	40	25	SCD171-0800-2-4-135HA25-HP285	30392256
9,00	9	280	238	225	40	25	SCD171-0900-2-4-135HA25-HP285	30392257
10,00	10	310	268	253	40	25	SCD171-1000-2-4-135HA25-HP285	30392258
11,00	11	340	293	277	45	25	SCD171-1100-2-4-135HA25-HP245	30392259
12,00	12	365	318	300	45	25	SCD171-1200-2-4-135HA25-HP245	30392260
14,00	14	425	373	352	50	25	SCD171-1400-2-4-135HA25-HP245	30392262

Raccomandazione per punta pilota

Come punta pilota si raccomanda di utilizzare MEGA-Drill-Steel-Plus (SCD601 - 3xD) con lo stesso diametro nominale.

L'angolo tra taglienti e le tolleranze del diametro sono concepiti per garantire un'ottima funzionalità, nonché una buona interazione tra la punta pilota e la punta per foratura profonda.

Le indicazioni tecniche di applicazione per la foratura profonda sono riportate nel capitolo Allegato tecnico.

Misure in mm.

Per i parametri di lavorazione consigliati, vedere la fine del capitolo.

Versioni speciali e altri rivestimenti disponibili su richiesta.

MEGA-Deep-Drill

Punta elicoidale in metallo duro integrale
SCD171 (30xD), adduzione interna del refrigerante

Versione:

Diametro punta: 3,00 – 12,00 mm
Tolleranza di foratura: \geq IT 9
Materiale da taglio: HP245 / HP285
Numero di taglienti: 2
Numero margini di guida: 4
Angolo tra taglienti: 135°
Angolo dell'elica: 30°

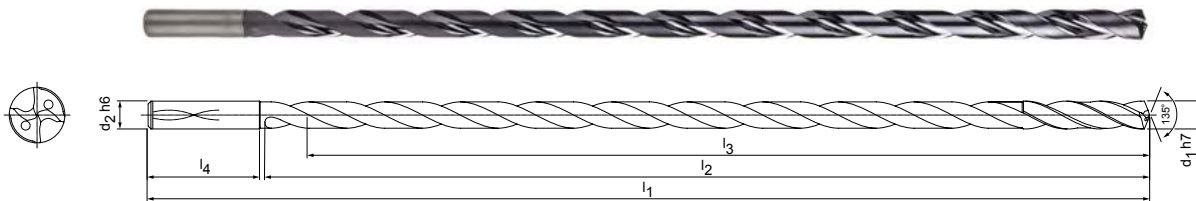
Serie selezionata per il magazzino con forma del codolo HA

Dimensioni						Rapporto L/d	Forma del codolo HA	
d ₁ h7	d ₂ h6	l ₁	l ₂	l ₃	l ₄		Specifiche	Codice
3,00	4	145	110	106	32	35	SCD171-0300-2-4-135HA30-HP285	30392264
4,00	4	160	126	120	32	30	SCD171-0400-2-4-135HA30-HP285	30392266
4,50	5	180	144	137	34	31	SCD171-0450-2-4-135HA30-HP285	30392267
5,00	5	195	159	152	34	30	SCD171-0500-2-4-135HA30-HP285	30392268
5,50	6	210	172	164	36	30	SCD171-0550-2-4-135HA30-HP285	30392269
6,00	6	230	192	183	36	31	SCD171-0600-2-4-135HA30-HP285	30392270
7,00	7	260	220	210	38	30	SCD171-0700-2-4-135HA30-HP285	30392271
8,00	8	295	253	241	40	30	SCD171-0800-2-4-135HA30-HP285	30392272
9,00	9	325	283	270	40	30	SCD171-0900-2-4-135HA30-HP285	30392273
10,00	10	360	318	303	40	30	SCD171-1000-2-4-135HA30-HP285	30392274
11,00	11	400	353	337	45	31	SCD171-1100-2-4-135HA30-HP245	30392275
12,00	12	430	383	365	45	30	SCD171-1200-2-4-135HA30-HP245	30392276

Raccomandazione per punta pilota

Come punta pilota si raccomanda di utilizzare MEGA-Drill-Steel-Plus (SCD601 - 3xD) con lo stesso diametro nominale.

L'angolo tra taglienti e le tolleranze del diametro sono concepiti per garantire un'ottima funzionalità, nonché una buona interazione tra la punta pilota e la punta per foratura profonda.

Le indicazioni tecniche di applicazione per la foratura profonda sono riportate nel capitolo Allegato tecnico.

Misure in mm.

Per i parametri di lavorazione consigliati, vedere la fine del capitolo.

Versioni speciali e altri rivestimenti disponibili su richiesta.

MEGA-Deep-Drill

Punta elicoidale in metallo duro integrale
SCD171 (40xD), adduzione interna del refrigerante

Versione:

Diametro punta: 4,00 – 6,00 mm
Tolleranza di foratura: \geq IT 9
Materiale da taglio: HP285
Numero di taglienti: 2
Numero margini di guida: 4
Angolo tra taglienti: 130°
Angolo dell'elica: 30°

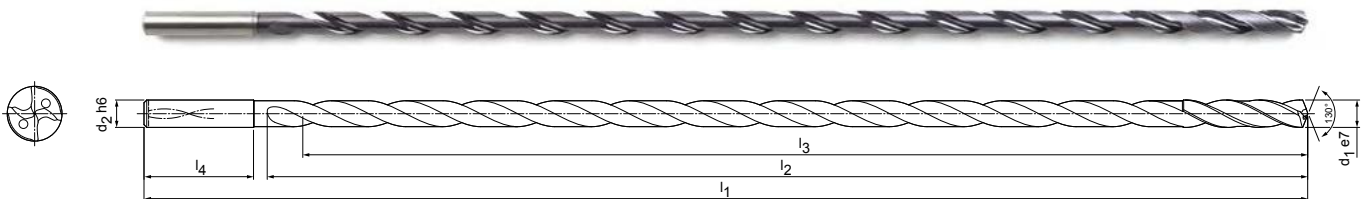

Serie selezionata per il magazzino con forma del codolo HA

Dimensioni						Rapporto L/d	Forma del codolo HA	
d ₁ e7	d ₂ h6	l ₁	l ₂	l ₃	l ₄		Specifiche	Codice
4,00	4	205	170	164	32	43	SCD171-0400-2-4-130HA40-HP285	30549867
5,00	5	245	208	201	34	42	SCD171-0500-2-4-130HA40-HP285	30549869
6,00	6	290	250	241	36	42	SCD171-0600-2-4-130HA40-HP285	30549871

Raccomandazione per punta pilota o di preforatura

Come punta pilota si raccomanda di utilizzare MEGA-Drill-Steel-Plus (SCD601 - 3xD) con lo stesso diametro nominale. Quindi eseguire la preforatura con MEGA-Deep-Drill (SCD171 - 20xD) e, anche in questo caso, con lo stesso diametro nominale. L'angolo tra taglienti e le tolleranze del diametro sono concepiti per garantire un'ottima funzionalità, nonché una buona interazione tra la punta pilota e la punta di foratura profonda.

Le indicazioni tecniche di applicazione per la foratura profonda sono riportate nel capitolo Allegato tecnico.

Misure in mm.

Per i parametri di lavorazione consigliati, vedere la fine del capitolo.

Versioni speciali e altri rivestimenti disponibili su richiesta.

MEGA-Deep-Drill-Alu

Punta elicoidale in metallo duro integrale
SCD181 (15xD), adduzione interna del refrigerante

Versione:

Diametro punta: 3,00 – 12,00 mm
Tolleranza di foratura: \geq IT 9
Materiale da taglio: HU680 / HU644
Numero di taglienti: 2
Numero margini di guida: 4
Angolo tra taglienti: 135°
Angolo dell'elica: 30°

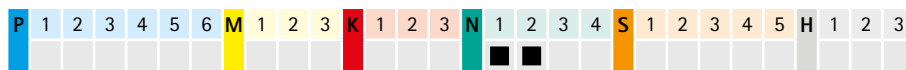
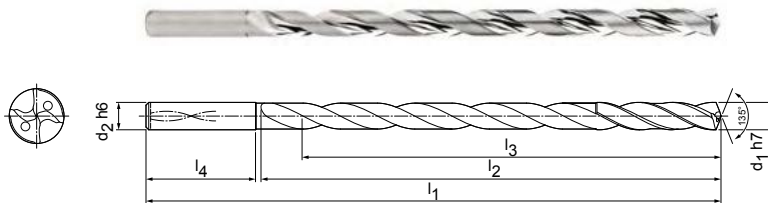
Serie selezionata per il magazzino con forma del codolo HA

Dimensioni						Rapporto L/d	Forma del codolo HA	
d ₁ h7	d ₂ h6	l ₁	l ₂	l ₃	l ₄		Specifiche	Codice
3,00	4	90	56	52	32	17	SCD181-0300-2-4-135HA15-HU680	30392277
3,50	4	100	66	61	32	17	SCD181-0350-2-4-135HA15-HU680	30392278
4,00	4	100	66	60	32	15	SCD181-0400-2-4-135HA15-HU680	30392279
5,00	5	120	84	77	34	15	SCD181-0500-2-4-135HA15-HU680	30392281
6,00	6	140	102	93	36	16	SCD181-0600-2-4-135HA15-HU680	30392283
7,00	7	155	115	105	38	15	SCD181-0700-2-4-135HA15-HU680	30392284
8,00	8	175	133	121	40	15	SCD181-0800-2-4-135HA15-HU680	30392285
10,00	10	210	168	153	40	15	SCD181-1000-2-4-135HA15-HU680	30392287
12,00	12	250	203	185	45	15	SCD181-1200-2-4-135HA15-HU644	30392289

Raccomandazione per punta pilota

Come punta pilota si raccomanda di utilizzare MEGA-Drill-Alu (SCD131 - 3xD/5xD) con lo stesso diametro nominale.

L'angolo tra taglienti e le tolleranze del diametro sono concepiti per garantire un'ottima funzionalità, nonché una buona interazione tra la punta pilota e la punta per foratura profonda.

Le indicazioni tecniche di applicazione per la foratura profonda sono riportate nel capitolo Allegato tecnico.

Misure in mm.

Per i parametri di lavorazione consigliati, vedere la fine del capitolo.

Versioni speciali e altri rivestimenti disponibili su richiesta.

MEGA-Deep-Drill-Alu

Punta elicoidale in metallo duro integrale
SCD181 (20xD), adduzione interna del refrigerante

Versione:

Diametro punta: 3,00 – 12,00 mm
Tolleranza di foratura: \geq IT 9
Materiale da taglio: HU680 / HU644
Numero di taglienti: 2
Numero margini di guida: 4
Angolo tra taglienti: 135°
Angolo dell'elica: 30°

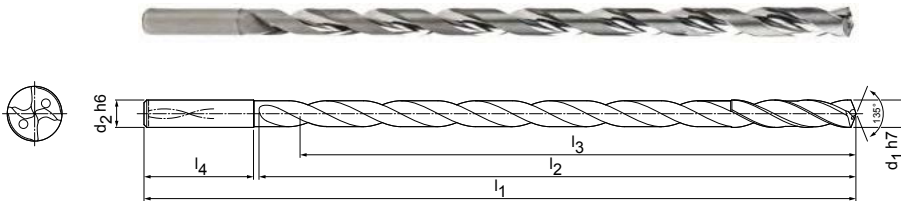
Serie selezionata per il magazzino con forma del codolo HA

Dimensioni						Rapporto L/d	Forma del codolo HA	
d ₁ h7	d ₂ h6	l ₁	l ₂	l ₃	l ₄		Specifiche	Codice
3,00	4	110	74	70	32	23	SCD181-0300-2-4-135HA20-HU680	30392294
4,00	4	120	86	80	32	20	SCD181-0400-2-4-135HA20-HU680	30392296
5,00	5	145	109	102	34	20	SCD181-0500-2-4-135HA20-HU680	30392298
5,50	6	160	120	112	36	20	SCD181-0550-2-4-135HA20-HU680	30392299
6,00	6	170	130	121	36	20	SCD181-0600-2-4-135HA20-HU680	30392300
7,00	7	190	150	140	38	20	SCD181-0700-2-4-135HA20-HU680	30392301
8,00	8	215	173	161	40	20	SCD181-0800-2-4-135HA20-HU680	30392302
10,00	10	260	218	203	40	20	SCD181-1000-2-4-135HA20-HU680	30392304
12,00	12	305	258	240	45	20	SCD181-1200-2-4-135HA20-HU644	30392306

Raccomandazione per punta pilota

Come punta pilota si raccomanda di utilizzare MEGA-Drill-Alu (SCD131 - 3xD/5xD) con lo stesso diametro nominale.

L'angolo tra taglienti e le tolleranze del diametro sono concepiti per garantire un'ottima funzionalità, nonché una buona interazione tra la punta pilota e la punta per foratura profonda.

Le indicazioni tecniche di applicazione per la foratura profonda sono riportate nel capitolo Allegato tecnico.

Misure in mm.

Per i parametri di lavorazione consigliati, vedere la fine del capitolo.

Versioni speciali e altri rivestimenti disponibili su richiesta.

MEGA-Deep-Drill-Alu

Punta elicoidale in metallo duro integrale
SCD181 (25xD), adduzione interna del refrigerante

Versione:

Diametro punta: 3,00 – 10,00 mm
Tolleranza di foratura: \geq IT 9
Materiale da taglio: HU680
Numero di taglienti: 2
Numero margini di guida: 4
Angolo tra taglienti: 135°
Angolo dell'elica: 30°

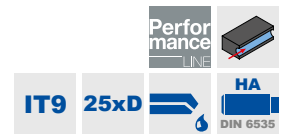
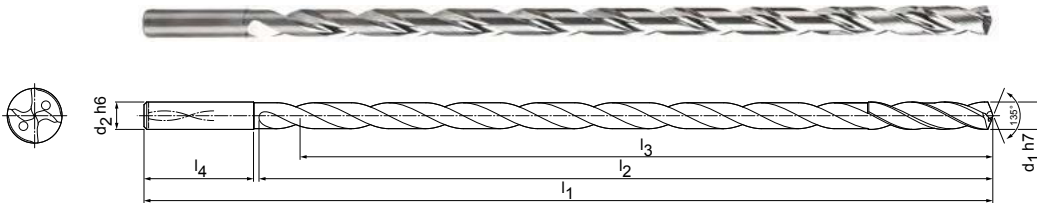
Serie selezionata per il magazzino con forma del codolo HA

Dimensioni						Rapporto L/d	Forma del codolo HA	
d ₁ h7	d ₂ h6	l ₁	l ₂	l ₃	l ₄		Specifiche	Codice
3,00	4	125	91	87	32	29	SCD181-0300-2-4-135HA25-HU680	30392311
4,00	4	140	106	100	32	25	SCD181-0400-2-4-135HA25-HU680	30392313
5,00	5	170	134	127	34	25	SCD181-0500-2-4-135HA25-HU680	30392315
6,00	6	200	160	151	36	25	SCD181-0600-2-4-135HA25-HU680	30392317
7,00	7	225	185	175	38	25	SCD181-0700-2-4-135HA25-HU680	30392318
8,00	8	255	213	201	40	25	SCD181-0800-2-4-135HA25-HU680	30392319
10,00	10	310	268	253	40	25	SCD181-1000-2-4-135HA25-HU680	30392321

Raccomandazione per punta pilota

Come punta pilota si raccomanda di utilizzare MEGA-Drill-Alu (SCD131 - 3xD/5xD) con lo stesso diametro nominale.

L'angolo tra taglienti e le tolleranze del diametro sono concepiti per garantire un'ottima funzionalità, nonché una buona interazione tra la punta pilota e la punta per foratura profonda.

Le indicazioni tecniche di applicazione per la foratura profonda sono riportate nel capitolo Allegato tecnico.

Misure in mm.

Per i parametri di lavorazione consigliati, vedere la fine del capitolo.

Versioni speciali e altri rivestimenti disponibili su richiesta.

MEGA-Deep-Drill-Alu

Punta elicoidale in metallo duro integrale
SCD181 (30xD), adduzione interna del refrigerante

Versione:

Diametro punta: 4,00 - 6,00 mm
Tolleranza di foratura: \geq IT 9
Materiale da taglio: HU680
Numero di taglienti: 2
Numero margini di guida: 4
Angolo tra taglienti: 135°
Angolo dell'elica: 30°

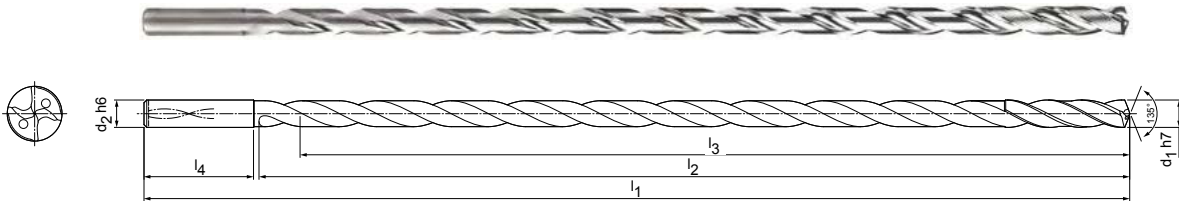
Serie selezionata per il magazzino con forma del codolo HA

Dimensioni						Rapporto L/d	Forma del codolo HA	
d ₁ h7	d ₂ h6	l ₁	l ₂	l ₃	l ₄		Specifiche	Codice
4,00	4	160	126	120	32	30	SCD181-0400-2-4-135HA30-HU680	30392328
4,50	5	180	144	137	34	31	SCD181-0450-2-4-135HA30-HU680	30392329
5,00	5	195	159	152	34	30	SCD181-0500-2-4-135HA30-HU680	30392330
6,00	6	230	192	183	36	31	SCD181-0600-2-4-135HA30-HU680	30392332

Raccomandazione per punta pilota

Come punta pilota si raccomanda di utilizzare MEGA-Drill-Alu (SCD131 - 3xD/5xD) con lo stesso diametro nominale.

L'angolo tra taglienti e le tolleranze del diametro sono concepiti per garantire un'ottima funzionalità, nonché una buona interazione tra la punta pilota e la punta per foratura profonda.

Le indicazioni tecniche di applicazione per la foratura profonda sono riportate nel capitolo Allegato tecnico.

Misure in mm.

Per i parametri di lavorazione consigliati, vedere la fine del capitolo.

Versioni speciali e altri rivestimenti disponibili su richiesta.

MEGA-Deep-Drill-Alu

Punta elicoidale in metallo duro integrale
SCD181 (40xD), adduzione interna del refrigerante

Versione:

Diametro punta: 6,00 - 7,00 mm
Tolleranza di foratura: \geq IT 9
Materiale da taglio: HU680
Numero di taglienti: 2
Numero margini di guida: 4
Angolo tra taglienti: 130°
Angolo dell'elica: 30°

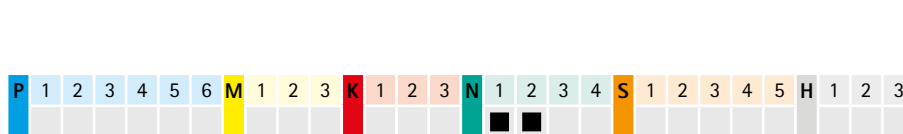
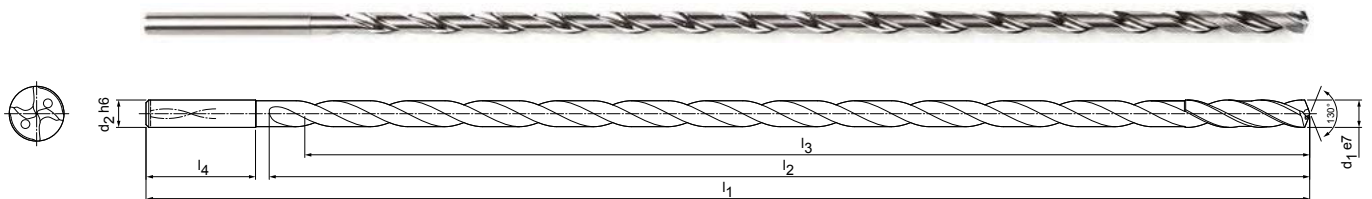
Serie selezionata per il magazzino con forma del codolo HA

Dimensioni						Rapporto L/d	Forma del codolo HA	
d ₁ h7	d ₂ h6	l ₁	l ₂	l ₃	l ₄		Specifiche	Codice
6,00	6	290	250	241	36	42	SCD181-0600-2-4-130HA40-HU680	30549881
7,00	7	330	290	280	38	41	SCD181-0700-2-4-130HA40-HU680	30549882

Raccomandazione per punta pilota

Come punta pilota si raccomanda di utilizzare MEGA-Drill-Alu (SCD131 - 3xD/5xD) con lo stesso diametro nominale.

L'angolo tra taglienti e le tolleranze del diametro sono concepiti per garantire un'ottima funzionalità, nonché una buona interazione tra la punta pilota e la punta per foratura profonda.

Le indicazioni tecniche di applicazione per la foratura profonda sono riportate nel capitolo Allegato tecnico.

Misure in mm.

Per i parametri di lavorazione consigliati, vedere la fine del capitolo.

Versioni speciali e altri rivestimenti disponibili su richiesta.



Parametri di lavorazione consigliati per punte per foratura profonda

Avanzamento e velocità di taglio

MEGA-Pilot-Drill | SCD581

GTM*		Materiale	Resistenza/durezza [N/mm ²] [HRC]
P	P1	P1.1 Acciai da costruzione, automatici, da cementazione e da bonifica, non legati	< 700
		P1.2 Acciai da costruzione, automatici, da cementazione e da bonifica, non legati	< 1.200
	P2	P2.1 Acciai da nitrurazione, da cementazione e da bonifica, legati	< 900
		P2.2 Acciai da nitrurazione, da cementazione e da bonifica, legati	< 1.400
	P3	P3.1 Acciai per utensili, per cuscinetti volventi, armonici e per lavorazioni veloci**	< 800
		P3.2 Acciai per utensili, per cuscinetti volventi, armonici e per lavorazioni veloci**	< 1.000
		P3.3 Acciai per utensili, per cuscinetti volventi, armonici e per lavorazioni veloci**	< 1.500
	P5	P5.1 Acciaio fuso	
M	M1	M1.1 Acciai inossidabili, austenitici	< 700
		M1.2 Acciai inossidabili, ferritici/austenitici (Duplex)	< 1.000
K	K1	K1.1 Ghisa con grafite lamellare (ghisa grigia), GJL	< 300
		K2.1 Ghisa con grafite sferoidale, GJS	< 500
	K2	K2.2 Ghisa con grafite sferoidale, GJS	≤ 800
		K2.3 Ghisa con grafite sferoidale, GJS	> 800
	K3	K3.1 Ghisa con grafite vermicolare, GJV; acciaio fuso malleabile, GJM	< 500
		K3.2 Ghisa con grafite vermicolare, GJV; acciaio fuso malleabile, GJM	> 500

* Gruppi di materiale MAPAL

** Qualora la somma dei componenti di lega Cr, Mo, Ni, V, W equivalesse a > 8%, selezionare il gruppo di materiale MAPAL immediatamente superiore.

	Velocità di taglio v_c [m/min]				Avanzamento f [mm] con diametro punta					
	Adduzione interna del refrigerante	Raffreddamento esterno	MQL	Aria	1,00	1,20	1,60	1,90	2,40	3,00
	80	70	70		0,05	0,06	0,06	0,07	0,08	0,09
	70	60	60		0,07	0,07	0,08	0,09	0,10	0,11
	80	70	70		0,06	0,07	0,08	0,08	0,10	0,11
	55	50	50		0,06	0,06	0,07	0,07	0,08	0,09
	60	50	50		0,06	0,06	0,07	0,07	0,08	0,10
	50	45	45		0,05	0,05	0,06	0,07	0,07	0,08
	50	35	40		0,05	0,05	0,05	0,06	0,06	0,07
	80	70	70		0,06	0,07	0,08	0,08	0,10	0,11
	45	30	30		0,04	0,04	0,05	0,05	0,06	0,06
	95	70	70	70	0,06	0,07	0,08	0,09	0,10	0,12
	130	80	95	95	0,07	0,07	0,08	0,09	0,11	0,13
	80	60	60		0,06	0,07	0,08	0,09	0,10	0,11
	70	65	65		0,07	0,08	0,08	0,09	0,11	0,12
	65	55	55		0,06	0,07	0,08	0,08	0,09	0,11

I parametri di lavorazione indicati sono valori orientativi.

I dati ottimali per la specifica applicazione devono essere rilevati eseguendo diversi tentativi o durante l'effettiva lavorazione.

Parametri di lavorazione consigliati per punte per foratura profonda

Avanzamento e velocità di taglio

MEGA-Deep-Drill | SCD171

GTM*		Materiale	Resistenza/durezza [N/mm ²] [HRC]
P	P1	P1.1 Acciai da costruzione, automatici, da cementazione e da bonifica, non legati	< 700
		P1.2 Acciai da costruzione, automatici, da cementazione e da bonifica, non legati	< 1.200
	P2	P2.1 Acciai da nitrurazione, da cementazione e da bonifica, legati	< 900
		P2.2 Acciai da nitrurazione, da cementazione e da bonifica, legati	< 1.400
	P3	P3.1 Acciai per utensili, per cuscinetti volventi, armonici e per lavorazioni veloci**	< 800
		P3.2 Acciai per utensili, per cuscinetti volventi, armonici e per lavorazioni veloci**	< 1.000
		P3.3 Acciai per utensili, per cuscinetti volventi, armonici e per lavorazioni veloci**	< 1.500
	P5	P5.1 Acciaio fuso	
K	K1	K1.1 Ghisa con grafite lamellare (ghisa grigia), GJL	< 300
		K2.1 Ghisa con grafite sferoidale, GJS	< 500
	K2	K2.2 Ghisa con grafite sferoidale, GJS	≤ 800
		K2.3 Ghisa con grafite sferoidale, GJS	> 800
	K3	K3.1 Ghisa con grafite vermicolare, GJV; acciaio fuso malleabile, GJM	< 500
		K3.2 Ghisa con grafite vermicolare, GJV; acciaio fuso malleabile, GJM	> 500

MEGA-Deep-Drill-Alu | SCD181

GTM*		Materiale	Resistenza/durezza [N/mm ²] [HRC]
N	N1	N1.1 Alluminio, non legato e legato < 3% Si	
		N1.2 Alluminio, legato ≤ 7% Si	
		N1.3 Alluminio, legato > 7-12% Si	
		N1.4 Alluminio, legato > 12% Si	
	N2	N2.1 Rame, non legato e bassolegato	< 300
		N2.2 Rame, legato	> 300
		N2.3 Ottone, bronzo, ghisa rossa	< 1.200

* Gruppi di materiale MAPAL

** Qualora la somma dei componenti di lega Cr, Mo, Ni, V, W equivalesse a > 8%, selezionare il gruppo di materiale MAPAL immediatamente superiore.

	Velocità di taglio v_c [m/min]			Avanzamento f [mm] con diametro punta					
	Adduzione interna del	MQL	Aria	1,00	2,00	4,00	6,00	9,00	16,00
	90	80		0,04	0,06	0,09	0,13	0,19	0,27
	80	70		0,06	0,08	0,11	0,16	0,24	0,34
	90	75		0,05	0,07	0,10	0,16	0,23	0,32
	65	55		0,05	0,07	0,09	0,13	0,18	0,25
	70	60		0,05	0,06	0,09	0,14	0,21	0,29
	55	50		0,04	0,06	0,08	0,12	0,17	0,23
	55	45		0,04	0,05	0,07	0,09	0,13	0,18
	90	75		0,05	0,07	0,10	0,16	0,23	0,32
	110	75	75	0,14	0,18	0,25	0,32	0,41	0,53
	145	110	110	0,14	0,18	0,24	0,30	0,38	0,49
	90	70		0,13	0,16	0,21	0,26	0,33	0,42
	55	45		0,10	0,12	0,14	0,18	0,22	0,28
	80	70		0,14	0,18	0,22	0,28	0,36	0,46
	70	65		0,12	0,15	0,18	0,23	0,29	0,36

	Velocità di taglio v_c [m/min]			Avanzamento f [mm] con diametro punta					
	Adduzione interna del	MQL	Aria	3,00	4,00	5,50	7,50	10,50	16,00
	300	250		0,11	0,13	0,16	0,20	0,25	0,32
	250	200		0,13	0,16	0,21	0,26	0,33	0,42
	220	180		0,13	0,16	0,21	0,26	0,33	0,42
	180	150		0,13	0,16	0,21	0,26	0,33	0,42
	140			0,09	0,11	0,14	0,17	0,21	0,27
	120			0,11	0,14	0,17	0,22	0,28	0,35
	200	160	120	0,14	0,18	0,25	0,32	0,41	0,53

I parametri di lavorazione indicati sono valori orientativi.

I dati ottimali per la specifica applicazione devono essere rilevati eseguendo diversi tentativi o durante l'effettiva lavorazione.



FORATURA- ALESATURA

Foratori-alesatori

Tecnologia 290

Tritan-Drill-Reamer 292

Allegato tecnico

Parametri di lavorazione consigliati 298

TRITAN-DRILL-REAMER

La soluzione più precisa per forare e alesare in un'unica fase di lavoro

Per produrre nel modo più conveniente possibile, è utile raggruppare più fasi di lavorazione in un unico utensile. Tritan-Drill-Reamer di MAPAL consente di forare e alesare allo stesso tempo.

Tritan-Drill-Reamer è la soluzione sviluppata da MAPAL per ottenere fori di accoppiamento ancor più precisi con un unico utensile. Grazie a sei margini di guida per una guida

ottimale, scanalature di asporto trucioli finemente levigate con forma adattata per una buona asportazione dei trucioli e un tagliente trasversale autocentrante, il nuovo Tritan-Drill-Reamer convince su tutta la linea.

Il tagliente trasversale autocentrante assicura un'eccellente precisione di posizione e un migliore centraggio. I taglienti garantiscono un'eccellente circolarità del foro di accoppiamento e massime prestazioni. I margini di guida producono superfici perfette.

CARATTERISTICHE

- Combinazione di foratura e alesatura
- Per lunghezze supporto 3xD e 5xD
- Tre taglienti e sei margini di guida
- Con adduzione interna del refrigerante
- Versioni tolleranza $\pm 0,003$ mm e H7

VANTAGGI

- Riduzione dei tempi produttivi e non produttivi
- Prestazioni eccellenti e massima precisione
- Alta precisione di posizionamento
- Ottima circolarità

Caratteristiche utensile nel dettaglio

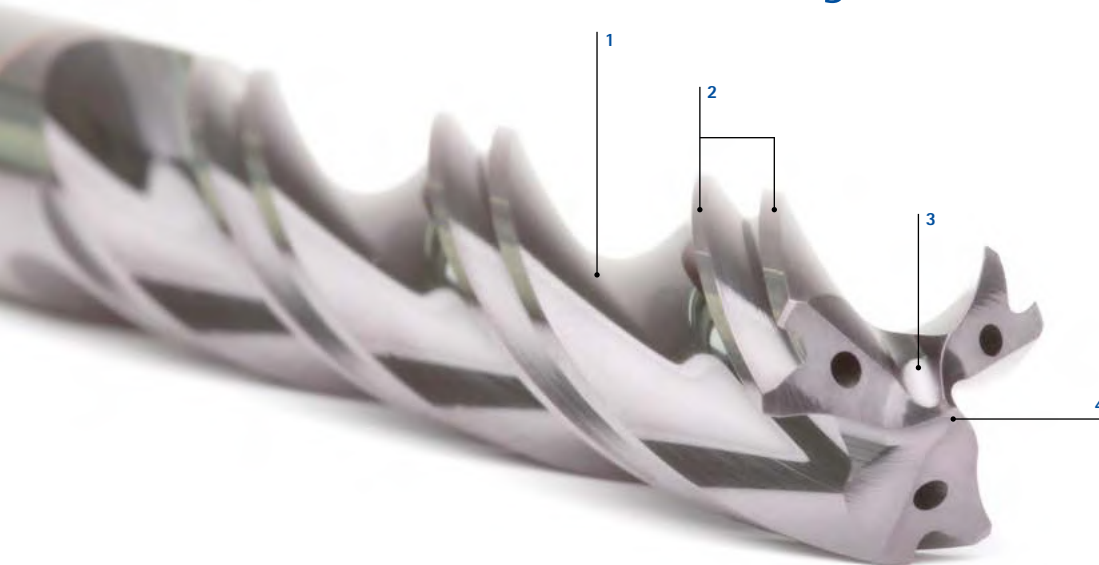

1 Profilo della scanalatura sottoposto a finissima levigatura

2 Sei margini di guida

3 Punta innovativa

4 Tagliente trasversale autocentrante



Sei margini di guida

- Per caratteristiche di guida eccellenti
- Per la realizzazione di fori di accoppiamento ad elevata redditività e precisione con un solo utensile



Punta di centraggio innovativa

- Tagliente trasversale autocentrante per un'eccellente precisione di posizione e un migliore centraggio



Profilo della scanalatura sottoposto a finissima levigatura

- Scanalature di asporto trucioli finemente levigate con forma adattata per una buona asportazione dei trucioli



Confronto Tritan-Drill-Reamer e soluzione a due taglienti

Scostamento del diametro rispetto al diametro utensile misurato (42CrMoS4)

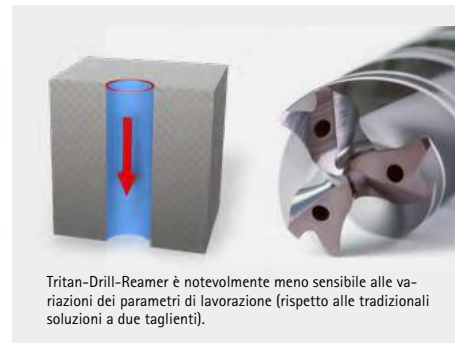
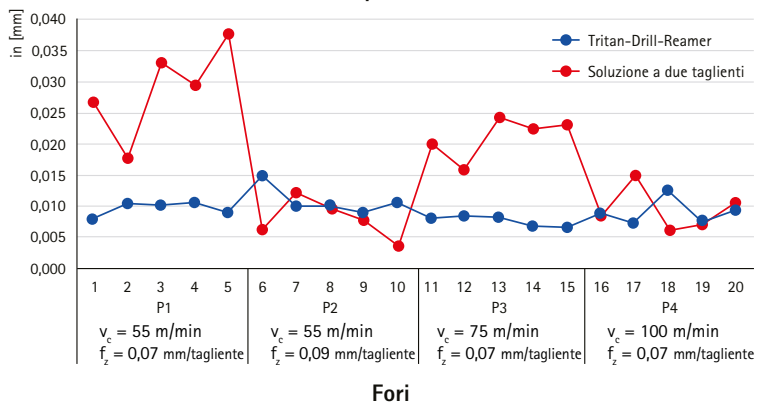

Circolarità su 600 fori

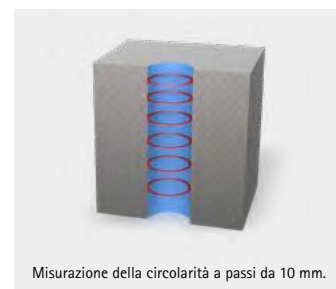
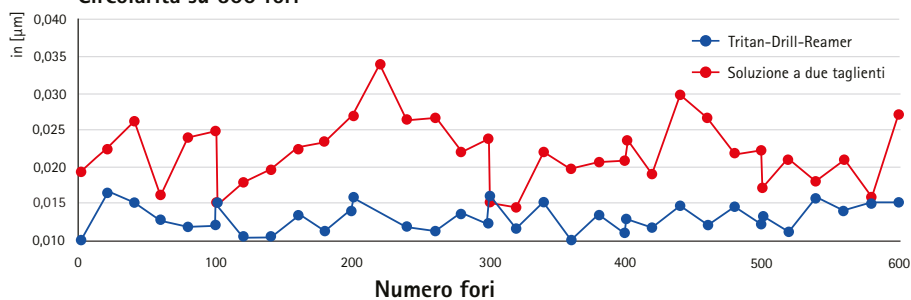

Tritan-Drill-Reamer

Foratore-alesatore
SDR301G (3xD), adduzione interna del refrigerante

Versione:
 Diametro punta: 3,80 – 20,05 mm
 Tolleranza di foratura: ≥ IT 7
 Materiale da taglio: HP358
 Numero di taglienti: 3
 Numero margini di guida: 6
 Angolo tra taglienti: 140°
 Angolo dell'elica: 30°

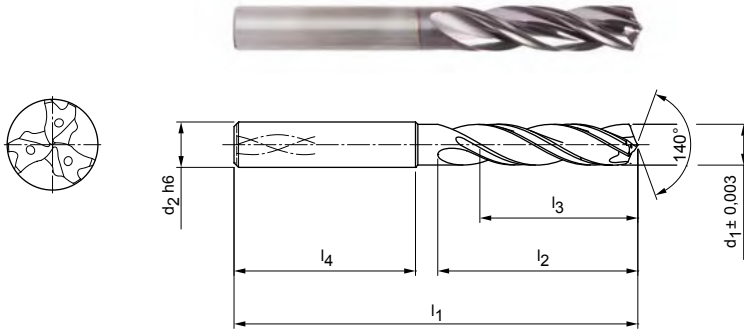

Serie selezionata per il magazzino con forma del codolo HA

Dimensioni						Forma del codolo HA	
d1 +/-0,003	d2 h6	l1	l2	l3	l4	Specifiche	Codice
3,99	6	66	24	17	36	SDR301G-3.990+3-3-HA03-HP358	31196569
4,00	6	66	24	17	36	SDR301G-4.000+3-3-HA03-HP358	31196570
4,01	6	66	24	17	36	SDR301G-4.010+3-3-HA03-HP358	31196571
4,99	6	66	28	20	36	SDR301G-4.990+3-3-HA03-HP358	31196575
5,00	6	66	28	20	36	SDR301G-5.000+3-3-HA03-HP358	31196576
5,01	6	66	28	20	36	SDR301G-5.010+3-3-HA03-HP358	31196577
5,02	6	66	28	20	36	SDR301G-5.020+3-3-HA03-HP358	31196578
5,99	6	66	28	20	36	SDR301G-5.990+3-3-HA03-HP358	31196581
6,00	6	66	28	20	36	SDR301G-6.000+3-3-HA03-HP358	31196582
6,01	6	66	28	20	36	SDR301G-6.010+3-3-HA03-HP358	31196583
7,99	8	79	41	29	36	SDR301G-7.990+3-3-HA03-HP358	31196587
8,00	8	79	41	29	36	SDR301G-8.000+3-3-HA03-HP358	31196588
8,01	8	79	41	29	36	SDR301G-8.010+3-3-HA03-HP358	31196589
9,99	10	89	47	35	40	SDR301G-9.990+3-3-HA03-HP358	31196593
10,00	10	89	47	35	40	SDR301G-10.000+3-3-HA03-HP358	31196594
10,01	10	89	47	35	40	SDR301G-10.010+3-3-HA03-HP358	31196595
10,02	10	89	47	35	40	SDR301G-10.020+3-3-HA03-HP358	31196596
11,99	12	102	55	40	45	SDR301G-11.990+3-3-HA03-HP358	31196599
12,00	12	102	55	40	45	SDR301G-12.000+3-3-HA03-HP358	31196600
12,01	12	102	55	40	45	SDR301G-12.010+3-3-HA03-HP358	31196601
13,99	14	107	60	43	45	SDR301G-13.990+3-3-HA03-HP358	31196605
14,00	14	107	60	43	45	SDR301G-14.000+3-3-HA03-HP358	31196606
14,01	14	107	60	43	45	SDR301G-14.010+3-3-HA03-HP358	31196607
15,99	16	115	65	45	48	SDR301G-15.990+3-3-HA03-HP358	31196611
16,00	16	115	65	45	48	SDR301G-16.000+3-3-HA03-HP358	31196612
16,01	16	115	65	45	48	SDR301G-16.010+3-3-HA03-HP358	31196613

Tritan-Drill-Reamer | Foratore-alesatore SDR301G (3xD), adduzione interna del refrigerante

Caratteristiche configurabili

**Diametro:**

Diametro a libera scelta a passi da
0,001 mm

**Specifiche:**

SDR301G-[diametro]+3-3-HA03-HP358

Esempio:

SDR301G-4.001+3-3-HA03-HP358

Diametro utensile $d_1 = 4,001$ mm

Dimensioni serie configurabile

d_1 min.	d_1 max.	d_2 h6	l_1	l_2	l_3	l_4
3,800	4,700	6	66	24	17	36
4,701	6,050	6	66	28	20	36
6,051	8,050	8	79	41	29	36
8,051	10,050	10	89	47	35	40
10,051	12,050	12	102	55	40	45
12,970	14,050	14	107	60	43	45
14,970	16,050	16	115	65	45	48
16,800	18,050	18	123	73	51	48
18,700	20,050	20	131	79	55	50

Misure in mm.

Per fori di accoppiamento in classe di tolleranza fino a max. IT7, con sufficiente stabilità della macchina e raffreddamento.

Per un aiuto ai fini del calcolo del diametro nominale ottimale dei vari fori di accoppiamento, si rimanda al box informativo alla fine del capitolo.

Per i parametri di lavorazione consigliati, vedere la fine del capitolo.

Versioni speciali e altri rivestimenti disponibili su richiesta.

Tritan-Drill-Reamer

Foratore-alesatore

SDR301 (3xD), adduzione interna del refrigerante

Versione:

Diametro punta: 4,00 – 16,00 mm
 Tolleranza di foratura: \geq IT 7
 Materiale da taglio: HP358
 Numero di taglienti: 3
 Numero margini di guida: 6
 Angolo tra taglienti: 140°
 Angolo dell'elica: 30°

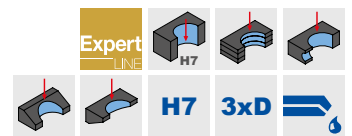
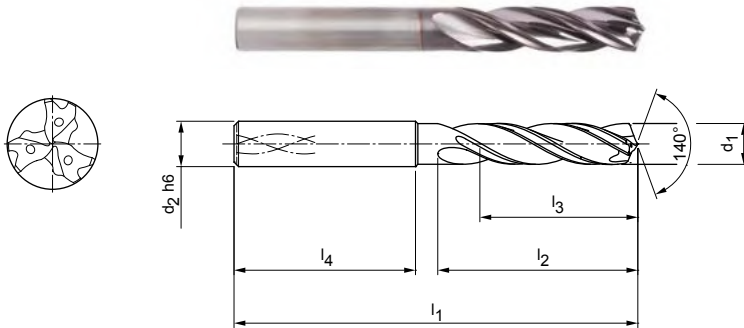

Serie selezionata per il magazzino con forma del codolo HA

Dimensioni						Forma del codolo HA	
d_1 H7	d_2 h6	l_1	l_2	l_3	l_4	Specifiche	Codice
4,00	6	66	24	17	36	SDR301-4.000H7-HA03-HP358	31196337
5,00	6	66	28	20	36	SDR301-5.000H7-HA03-HP358	31196338
6,00	6	66	28	20	36	SDR301-6.000H7-HA03-HP358	31196339
8,00	8	79	41	29	36	SDR301-8.000H7-HA03-HP358	31196560
10,00	10	89	47	35	40	SDR301-10.000H7-HA03-HP358	31196561
12,00	12	102	55	40	45	SDR301-12.000H7-HA03-HP358	31196562
14,00	14	107	60	43	45	SDR301-14.000H7-HA03-HP358	31196563
16,00	16	115	65	45	48	SDR301-16.000H7-HA03-HP358	31196564

Misure in mm.

Per fori di accoppiamento in classe di tolleranza H7, con sufficiente stabilità della macchina e raffreddamento.

Per i parametri di lavorazione consigliati, vedere la fine del capitolo.

Versioni speciali e altri rivestimenti disponibili su richiesta.

Tritan-Drill-Reamer

Foratore-alesatore
SDR301G (5xD), adduzione interna del refrigerante

Versione:

Diametro punta: 3,80 – 20,05 mm
Tolleranza di foratura: \geq IT 7
Materiale da taglio: HP358
Numero di taglienti: 3
Numero margini di guida: 6
Angolo tra taglienti: 140°
Angolo dell'elica: 30°

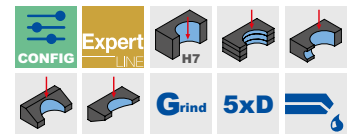
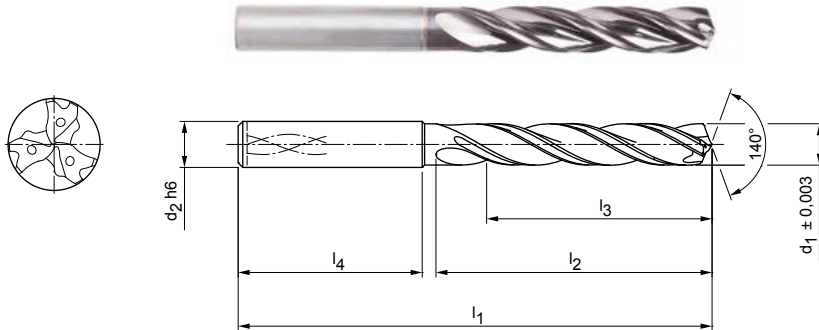

Serie selezionata per il magazzino con forma del codolo HA

Dimensioni						Forma del codolo HA	
$d_1 \pm 0,003$	$d_2 h6$	l_1	l_2	l_3	l_4	Specifiche	Codice
3,99	6	74	36	29	36	SDR301G-3.990+3-3-HA05-HP358	31196639
4,00	6	74	36	29	36	SDR301G-4.000+3-3-HA05-HP358	31196640
4,01	6	74	36	29	36	SDR301G-4.010+3-3-HA05-HP358	31196641
4,02	6	74	36	29	36	SDR301G-4.020+3-3-HA05-HP358	31196642
4,99	6	82	44	35	36	SDR301G-4.990+3-3-HA05-HP358	31196645
5,00	6	82	44	35	36	SDR301G-5.000+3-3-HA05-HP358	31196646
5,01	6	82	44	35	36	SDR301G-5.010+3-3-HA05-HP358	31196647
5,99	6	82	44	35	36	SDR301G-5.990+3-3-HA05-HP358	31196651
6,00	6	82	44	35	36	SDR301G-6.000+3-3-HA05-HP358	31196652
6,01	6	82	44	35	36	SDR301G-6.010+3-3-HA05-HP358	31196653
7,99	8	91	53	43	36	SDR301G-7.990+3-3-HA05-HP358	31196658
8,00	8	91	53	43	36	SDR301G-8.000+3-3-HA05-HP358	31196659
8,01	8	91	53	43	36	SDR301G-8.010+3-3-HA05-HP358	31196660
8,02	8	91	53	43	36	SDR301G-8.020+3-3-HA05-HP358	31196661
9,99	10	103	61	49	40	SDR301G-9.990+3-3-HA05-HP358	31196664
10,00	10	103	61	49	40	SDR301G-10.000+3-3-HA05-HP358	31196665
10,01	10	103	61	49	40	SDR301G-10.010+3-3-HA05-HP358	31196666
11,99	12	118	71	59	45	SDR301G-11.990+3-3-HA05-HP358	31196670
12,00	12	118	71	59	45	SDR301G-12.000+3-3-HA05-HP358	31196671
12,01	12	118	71	59	45	SDR301G-12.010+3-3-HA05-HP358	31196672
13,99	14	124	77	60	45	SDR301G-13.990+3-3-HA05-HP358	31196676
14,00	14	124	77	60	45	SDR301G-14.000+3-3-HA05-HP358	31196677
14,01	14	124	77	60	45	SDR301G-14.010+3-3-HA05-HP358	31196678
15,99	16	133	83	63	48	SDR301G-15.990+3-3-HA05-HP358	31196682
16,00	16	133	83	63	48	SDR301G-16.000+3-3-HA05-HP358	31196683
16,01	16	133	83	63	48	SDR301G-16.010+3-3-HA05-HP358	31196684

Prosegue alla pagina seguente.

Tritan-Drill-Reamer | Foratore-alesatore SDR301G (5xD), adduzione interna del refrigerante

Caratteristiche configurabili

**Diametro:**

Diametro a libera scelta a passi da 0,001 mm

**Specifiche:**

SDR301G-[diametro]+3-3-HA05-HP358

Esempio:

SDR301G-04001+3-3-HA05-HP358

Diametro utensile $d_1 = 4,001$ mm

Dimensioni serie configurabile

d_1 min.	d_1 max.	d_2 h6	l_1	l_2	l_3	l_4
3,800	4,700	6	74	36	29	36
4,701	6,050	6	82	44	35	36
6,051	8,050	8	91	53	43	36
8,051	10,050	10	103	61	49	40
10,051	12,050	12	118	71	56	45
12,970	14,050	14	124	77	60	45
14,970	16,050	16	133	83	63	48
16,800	18,050	18	143	93	71	48
18,700	20,050	20	153	101	77	50

Misure in mm.

Per fori di accoppiamento in classe di tolleranza fino a max. IT7, con sufficiente stabilità della macchina e raffreddamento.

Per un aiuto ai fini del calcolo del diametro nominale ottimale dei vari fori di accoppiamento, si rimanda al box informativo alla fine del capitolo.

Per i parametri di lavorazione consigliati, vedere la fine del capitolo.

Versioni speciali e altri rivestimenti disponibili su richiesta.

Tritan-Drill-Reamer

Foratore-alesatore

SDR301 (5xD), adduzione interna del refrigerante

Versione:

Diametro punta: 4,00 – 20,00 mm
 Tolleranza di foratura: \geq IT 7
 Materiale da taglio: HP358
 Numero di taglienti: 3
 Numero margini di guida: 6
 Angolo tra taglienti: 140°
 Angolo dell'elica: 30°

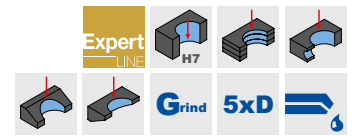
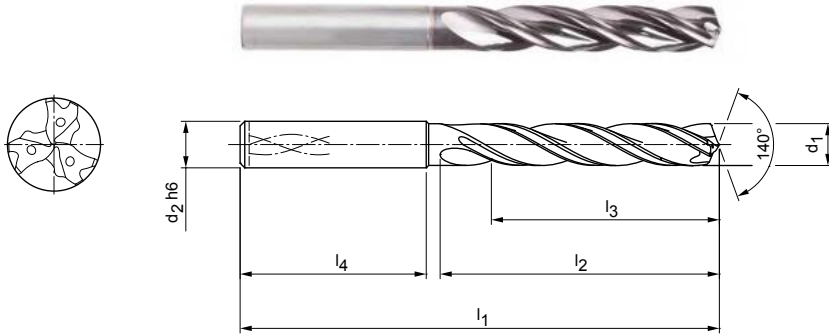

Serie selezionata per il magazzino con forma del codolo HA

Dimensioni						Forma del codolo HA	
d ₁ H7	d ₂ h6	l ₁	l ₂	l ₃	l ₄	Specifiche	Codice
4,00	6	74	36	29	36	SDR301-4.000H7-HA05-HP358	31196627
5,00	6	82	44	35	36	SDR301-5.000H7-HA05-HP358	31196628
6,00	6	82	44	35	36	SDR301-6.000H7-HA05-HP358	31196629
8,00	8	91	53	43	36	SDR301-8.000H7-HA05-HP358	31196630
10,00	10	103	61	49	40	SDR301-10.000H7-HA05-HP358	31196631
12,00	12	118	71	56	45	SDR301-12.000H7-HA05-HP358	31196632
14,00	14	124	77	60	45	SDR301-14.000H7-HA05-HP358	31196633
16,00	16	133	83	63	48	SDR301-16.000H7-HA05-HP358	31196634
18,00	18	143	93	71	48	SDR301-18.000H7-HA05-HP358	31196635
20,00	20	153	101	77	50	SDR301-20.000H7-HA05-HP358	31196636

Misure in mm.

Per fori di accoppiamento in classe di tolleranza H7, con sufficiente stabilità della macchina e raffreddamento.

Per i parametri di lavorazione consigliati, vedere la fine del capitolo.

Versioni speciali e altri rivestimenti disponibili su richiesta.

Parametri di lavorazione consigliati per foratori-alesatori

Avanzamento e velocità di taglio

Tritan-Drill-Reamer | SDR301

GTM*		Materiale	Resistenza/durezza [N/mm ²] [HRC]
P	P1	P1.1 Acciai da costruzione, automatici, da cementazione e da bonifica, non legati	< 700
		P1.2 Acciai da costruzione, automatici, da cementazione e da bonifica, non legati	< 1.200
	P2	P2.1 Acciai da nitrurazione, da cementazione e da bonifica, legati	< 900
		P2.2 Acciai da nitrurazione, da cementazione e da bonifica, legati	< 1.400
	P3	P3.1 Acciai per utensili, per cuscinetti volventi, armonici e per lavorazioni veloci**	< 800
		P3.2 Acciai per utensili, per cuscinetti volventi, armonici e per lavorazioni veloci**	< 1.000
		P3.3 Acciai per utensili, per cuscinetti volventi, armonici e per lavorazioni veloci**	< 1.500
	P5	P5.1 Acciaio fuso	
	K	K1	K1.1 Ghisa con grafite lamellare (ghisa grigia), GJL
K2.1 Ghisa con grafite sferoidale, GJS			< 500
K2		K2.2 Ghisa con grafite sferoidale, GJS	≤ 800
		K2.3 Ghisa con grafite sferoidale, GJS	> 800
K3		K3.1 Ghisa con grafite vermicolare, GJV; acciaio fuso malleabile, GJM	< 500
		K3.2 Ghisa con grafite vermicolare, GJV; acciaio fuso malleabile, GJM	> 500

ESEMPIO DI CALCOLO

Nota bene: il risultato può essere influenzato da ulteriori parametri, come macchina utensile o serraggio dell'utensile.

Formula per calcolare il diametro nominale dell'utensile ottimale:

$$(G_{OB} + G_{UB}) / 2$$

Esempio:

- Foro di accoppiamento: \varnothing 10 F7
- Misura massima foro G_{OB} : 10,028 mm
- Misura minima foro G_{UB} : 10,013 mm

$$\rightarrow (10,028 \text{ mm} + 10,013 \text{ mm}) / 2 = 10,021 \text{ mm} = \text{scelta diametro nominale utensile } 10,021 \text{ mm}$$

* Gruppi di materiale MAPAL

** Qualora la somma dei componenti di lega Cr, Mo, Ni, V, W equivalesse a > 8%, selezionare il gruppo di materiale MAPAL immediatamente superiore.

	Velocità di taglio v_c [m/min]				Avanzamento f [mm] con diametro punta					
	Adduzione interna del refrigerante	Raffreddamento esterno	MQL	Aria	4,00	5,50	7,50	10,50	14,50	20,00
	70	65	65		0,17	0,22	0,27	0,34	0,41	0,47
	65	55	55		0,22	0,27	0,34	0,42	0,51	0,59
	70	60	60		0,20	0,26	0,32	0,40	0,48	0,56
	50	40	40		0,17	0,21	0,26	0,32	0,38	0,44
	55	45	45		0,18	0,23	0,29	0,36	0,43	0,50
	40	40	40		0,15	0,19	0,24	0,30	0,36	0,41
	40	30	35		0,13	0,16	0,19	0,23	0,28	0,32
	70	60	60		0,20	0,26	0,32	0,40	0,48	0,56
	100	70	70	70	0,25	0,33	0,42	0,55	0,67	0,79
	135	85	100	100	0,24	0,32	0,40	0,51	0,62	0,72
	85	65	65		0,22	0,28	0,35	0,44	0,54	0,62
	50	35	45		0,11	0,13	0,16	0,20	0,24	0,28
	75	70	70		0,23	0,30	0,38	0,47	0,58	0,67
	70	60	60		0,20	0,25	0,31	0,38	0,46	0,53

I parametri di lavorazione indicati sono valori orientativi.

I dati ottimali per la specifica applicazione devono essere rilevati eseguendo diversi tentativi o durante l'effettiva lavorazione.

SOLUZIONI SPECIALI

Utensili di foratura in metallo duro integrale



Oltre al vasto programma standard di utensili di barenatura, MAPAL propone anche strumenti personalizzati.

Le necessità individuali dei clienti richiedono infatti soluzioni speciali, ideate su misura per svolgere specifiche operazioni di lavorazione. L'approfondito know-how nella lavorazione dei metalli e l'esperienza pluriennale fanno di MAPAL un partner competente a livello mondiale a cui rivolgersi sia per la realizzazione e la produzione di utensili speciali, sia per lo studio di processi di asportazione truciolo completi per la lavorazione di forature. L'assortimento include punte elicoidali e con scanalatura dritta, punte a gradino in metallo duro integrale e punte con riporto in PCD.

MAPAL è il partner ideale per realizzare soluzioni speciali su misura specifiche per applicazione.

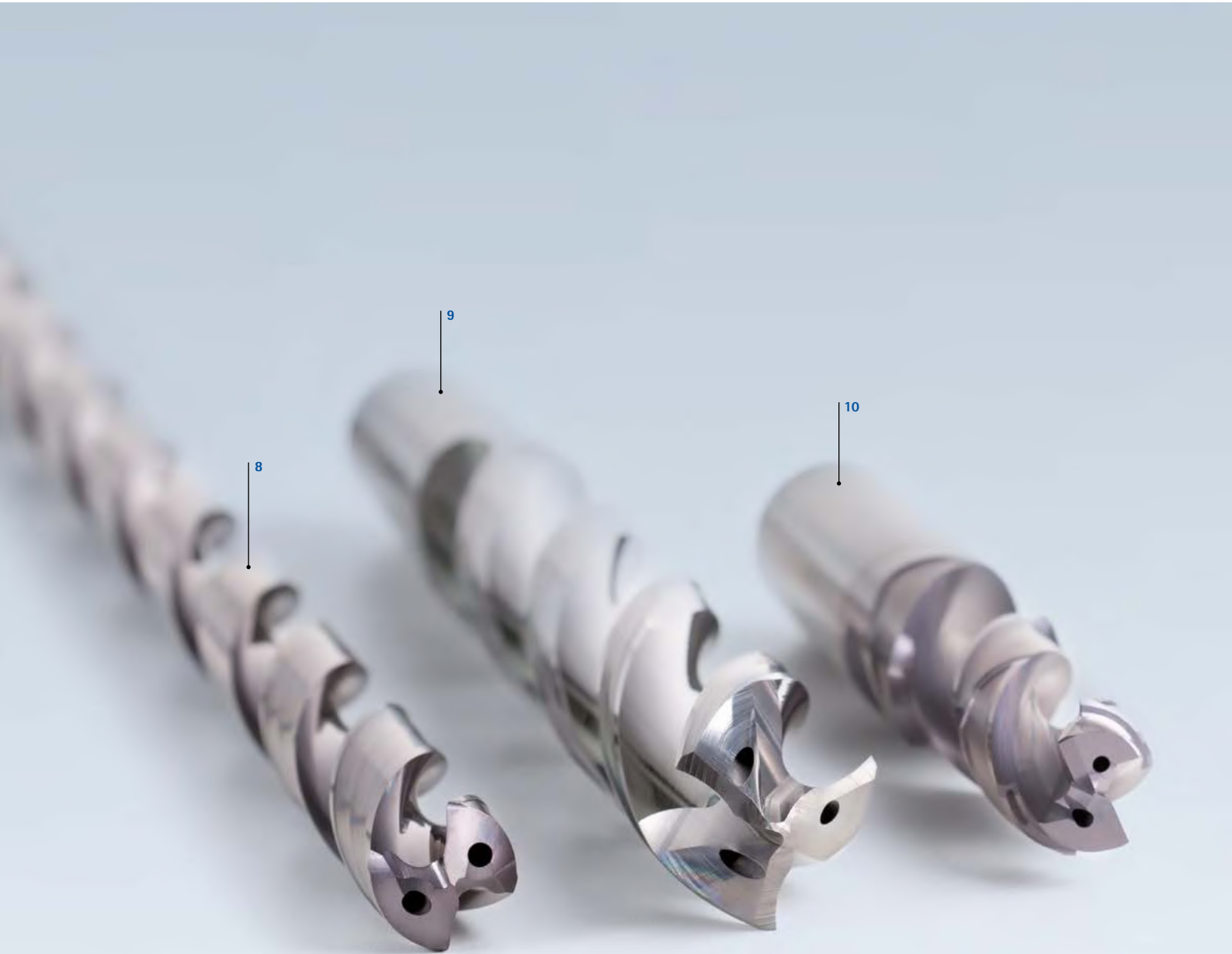

Strumenti personalizzati MAPAL per la foratura

- 1 Speciale punta a gradino in metallo duro integrale a tre taglienti, con tagliente trasversale autocentrante, per la lavorazione della biella in un unico processo
- 2 Punta a gradino in metallo duro integrale con tre margini di guida e rivestimento speciale per la lavorazione ad alta velocità
- 3 Punta per maschiatura in metallo duro integrale per la lavorazione della biella in un processo a 2 fasi
- 4 Punta a gradino in metallo duro integrale con tre margini di guida e rivestimento speciale per la lavorazione ad alta velocità di snodi dell'asse in ADI 900
- 5 Speciale punta di foratura in metallo duro integrale con geometria Tritan-Drill e rivestimento speciale per la lavorazione di turbocompressori
- 6 Foratore-alesatore a tre taglienti con taglienti di alesatura aggiuntivi sul contorno, con rivestimento speciale per la lavorazione di assi in GJS
- 7 Punta pilota in metallo duro integrale per la lavorazione della biella in un processo a 2 fasi
- 8 Punta per foratura profonda in metallo duro integrale con rivestimento speciale per la lavorazione di blocchi cilindri in GJV
- 9 Punta per alluminio in metallo duro integrale a tre taglienti, tagliente trasversale autocentrante e scanalature per trucioli levigate e lucidate per la lavorazione di AISi1
- 10 Punta a gradino in metallo duro integrale con affilatura frontale 180° per la lavorazione di valvole



SOLUZIONI SPECIALI

Foratura con PCD

Nella lavorazione di componenti in alluminio e altri metalli non ferrosi, per la foratura vengono impiegati per lo più utensili in PCD con scanalature dritte. Per garantire punte con prestazioni elevate, le caratteristiche dell'utensile sono studiate e combinate tra loro in modo ottimale. Le scanalature per trucioli sono levigate e lucidate per tutta la lunghezza della punta, al fine di ridurre al minimo possibile l'attrito dei trucioli. I taglienti in PCD sono perfettamente integrati e garantiscono un buon comportamento di taglio della punta. Questo contribuisce anche a ridurre l'apporto di calore al componente in lavorazione.

Per i processi con lubrificazione minimale (MQL), MAPAL ha adattato la posizione delle uscite del refrigerante sugli utensili specificamente per fare in modo che l'aerosol arrivi esattamente ai punti dove è necessaria la lubrificazione. In questo modo si riduce il rischio di taglienti di riporto e si aumenta la durata utile della punta di foratura.

I moderni processi di lavorazione richiedono tuttavia sempre più diffusamente utensili di barenatura con riporto in PCD con un grande angolo dell'elica.

Gli utensili elicoidali in PCD consentono infatti una lavorazione del foro particolarmente sicura e produttiva. Il "convoglio meccanico" a supporto dell'asportazione dei trucioli consente di evitare intasamenti o rotture dell'utensile. Gli angoli di spoglia fortemente positivi riducono le forze di taglio necessarie. È inoltre possibile eseguire in una sola fase di lavoro più operazioni diverse, come il processo di foratura e quello di barenatura. La riduzione del tempo di lavorazione porta ad un incremento della produttività, mantenendo nel contempo elevate sia la sicurezza dei processi che la qualità del foro.

Caratteristiche utensile nel dettaglio



1 Taglienti in PCD

2 Scanalatura per trucioli elicoidale e perfettamente levigata

3 Uscite del refrigerante ottimizzate per il processo di lubrificazione minimale

Taglienti in PCD integrati in modo ottimale

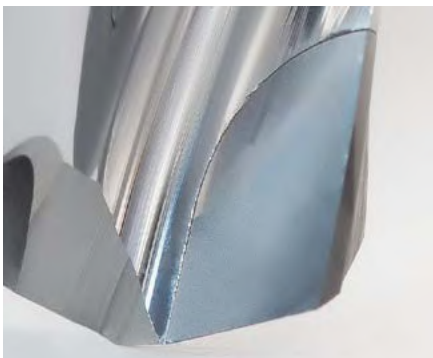

L'integrazione ottimale dei segmenti in PCD in una scanalatura elicoidale ed arrotondata da tutti i lati rappresenta una vera e propria sfida per la tecnica di produzione. La modernissima dotazione dei centri di produzione garantisce che gli utensili di barenatura elicoidali in PCD possano venire progettati e realizzati in modo sicuro e riproducibile. Al fine di garantire perfette prestazioni degli utensili, sia la progettazione che la costruzione sono ampiamente corredate da approfonditi dettagli relativi all'applicazione pratica, raccolti dai consulenti tecnici e dagli specialisti MAPAL nel settore.

Scanalatura per trucioli perfettamente levigata



Le scanalature per trucioli sono perfettamente levigate e lucidate, in modo da limitare l'attrito che si genera contro i trucioli e ridurre allo stesso tempo anche l'apporto di calore al componente in lavorazione. La versione elicoidale delle scanalature per trucioli consente un'asportazione a "convoglio meccanico" dei trucioli prodotti. Gli angoli di spoglia fortemente positivi riducono le forze di taglio necessarie.

Ottimale per processi con lubrificazione minimale



Il corretto posizionamento delle uscite del refrigerante nella lavorazione con lubrificazione minimale è determinante per le prestazioni della punta. L'aerosol deve infatti arrivare esattamente nei punti dove è necessaria la lubrificazione. In questo modo si riduce, ad esempio, il rischio di taglianti di riporto e si aumenta ovviamente anche la durata della punta.



ALESATURA E BARENATURA DI PRECISIONE

Massima precisione secondo il principio MAPAL



PANORAMICA PRODOTTI

Alesatura e barenatura di precisione

Gli utensili per la lavorazione fine di fori rappresentano la competenza centrale di MAPAL. La storia di grande successo, che ancora oggi MAPAL continua a scrivere nel settore, ha avuto inizio nel 1954 con il primo "prototipo di alesatore". Grazie a una pluridecennale esperienza, a continue evoluzioni e alla continua ottimizzazione di soluzioni e utensili, MAPAL assicura sempre la soluzione più adatta alle complessità di lavorazione e ai requisiti di precisione specifici. Accanto a soluzioni speciali su misura, MAPAL è oggi in grado di offrire anche un variegato assortimento standard di utensili per l'alesatura e la barenatura di precisione.

L'alesatura e la barenatura di precisione sono i processi più comunemente utilizzati nella lavorazione fine di fori, e convincono grazie ai risulta-

ti particolarmente precisi. Poiché la stessa precisione che gli utensili MAPAL garantiscono nella pratica non è altro che la base per la produzione degli utensili MAPAL. A seconda della complessità di lavorazione e dei requisiti in termini di precisione e superficie, MAPAL offre sempre la soluzione adatta:

Per ottenere la massima precisione sono disponibili alesatori a un tagliente, utensili per barenatura con pattini di guida, nonché taglienti WP. L'assortimento comprende inoltre alesatori fissi a più taglienti: alesatori a testina intercambiabile HPR abbinati a sistemi di serraggio ad alta precisione, alesatori ad alte prestazioni in metallo duro o cermet e sistemi per la lavorazione di grandi diametri.



Basic Line:
Basic
 LINE
 utensili universali, vasto campo di applicazione, bassi costi di acquisto

Performance Line:
Performance
 LINE
 utensili ad alte prestazioni, vasto campo di applicazione, elevata produttività nella produzione di serie

Expert Line:
Expert
 LINE
 utensili specifici per le applicazioni selezionate, massima precisione e massima produttività

Alesatori fissi a più taglienti



Alesatore ad alte prestazioni | FXR

Disponibili in diversi materiali da taglio e con svariati rivestimenti, gli alesatori ad alte prestazioni della serie FXR sono la scelta ideale per brevi tempi di ciclo. Consentono di lavorare in maniera conveniente e sicura praticamente qualsiasi materiale. Oltre ad azzerare gli oneri di regolazione, gli utensili sono disponibili nel range di diametro da 2,800 a 20,200 mm con tolleranze IT7.

Range di \varnothing : 2,800 - 20,200 mm*



Alesatori ad alte prestazioni con rivestimento | MOR/MRP

Per descrivere il sistema di alesatura della serie MonoReam bastano tre aggettivi: semplice, performante e standardizzato. I taglienti degli alesatori ad alte prestazioni della serie FXR sono brasati sul corpo base. Diversamente dalla serie FXR, gli alesatori MOR possono essere ricondizionati. A tale scopo, sono dotati di una vite di espansione che, allargando il diametro dell'alesatore, consente la riaffilatura.

Range di \varnothing : 3,850 - 40,200 mm*



Alesatore a testina intercambiabile HPR con attacco HFS

Laddove, in un range di diametro piccolo, è importante lavorare al massimo della redditività, la soluzione sono gli alesatori a testina intercambiabile HPR. L'eccezionale precisione dell'attacco HFS garantisce, nonostante il sistema a testina intercambiabile, una esatta concentricità e un'elevata precisione di cambio. L'utilizzo è estremamente semplice. Gli alesatori HPR sono disponibili con taglienti brasati fissi e con taglienti regolabili.

Range di \varnothing : 7,000 - 65,000 mm*



Utensili con pattini di guida



Alesatore a un tagliente

Quando si parla di precisione ai massimi livelli, gli alesatori monotagliente con pattini di guida secondo il principio MAPAL sono praticamente imbattibili. Gli inserti sono disponibili con due taglienti e imbrocchi speciali.

Range di \varnothing : 5,000 - 30,290 mm*



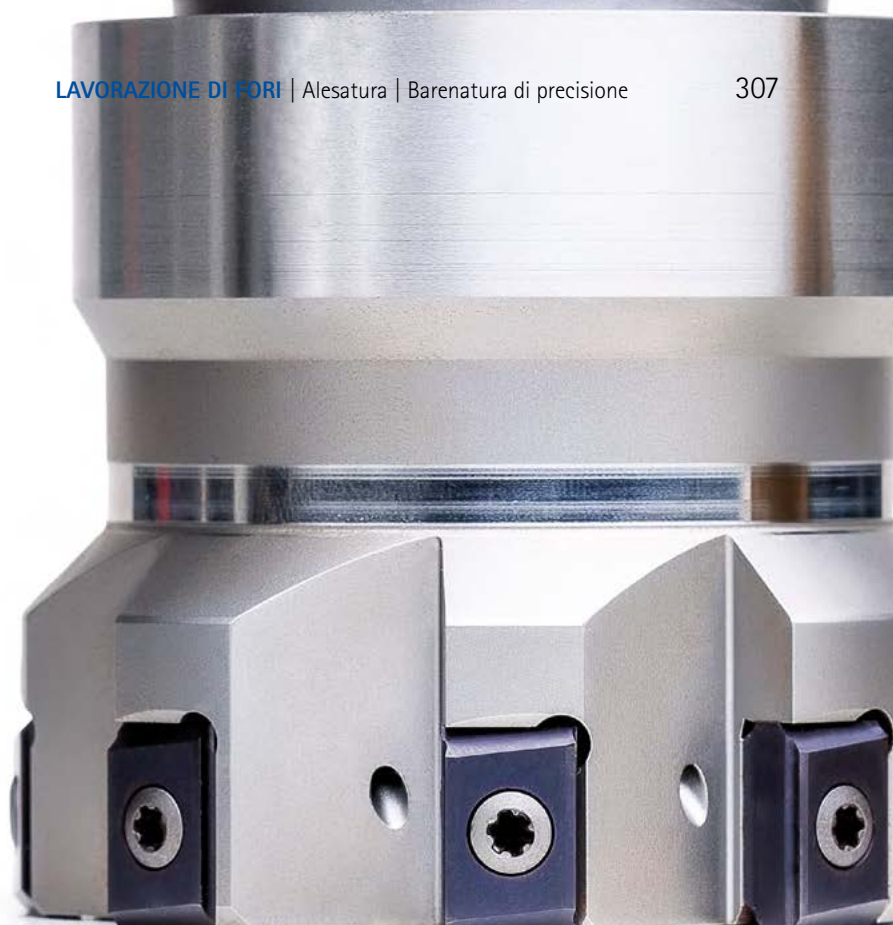

Soluzioni per grandi diametri

Soluzioni speciali



Sistema EasyAdjust

L'obiettivo primario perseguito con lo sviluppo del sistema EasyAdjust risiede nella drastica riduzione dei costi di regolazione per gli utensili dotati di tecnologia a pattini di guida. Fulcro del sistema è un'innovativa cartuccia, che ospita gli inserti a sei o quattro taglienti garantendo stabilità e assenza di gioco. La rastremazione del tagliente secondario è già integrata nella cartuccia, riducendo così i costi di regolazione. La rastremazione rimane invariata anche durante l'impostazione del diametro, grazie alla guida esatta della cartuccia su di un perno guida di precisione.

Range di \varnothing : da 20,000 mm*

P M K N S H

Soluzioni per grandi diametri

Alesatori ad alte prestazioni a più taglienti per grandi range di diametro. HPR400 - rapida sostituzione dei taglienti in loco senza lunghe procedure di riaffilatura e ricondizionamento. HPR400 plus - quattro taglienti al posto dell'unico tagliente finora presente. Semplice ribaltamento e sostituzione degli inserti.

Range di \varnothing : 63,000 - 319,999 mm*

P M K N H

Utensili speciali su misura

Operazioni di lavorazione specifiche richiedono utensili speciali. Per questo MAPAL offre utensili di alesatura in versioni speciali, realizzati su misura in base alle esigenze del cliente. Grazie a speciali geometrie di imbocco e particolari rivestimenti, nonché mediante appositi utensili a gradini, ogni operazione viene eseguita in maniera ottimale. Le soluzioni combinate con ulteriori tecnologie per utensili MAPAL possono incrementare ulteriormente la produttività e ridurre i tempi morti.

SISTEMA DI SELEZIONE

Alesatori fissi a più taglienti | Utensili con pattini di guida



Alesatori fissi a più taglienti

La prima scelta per le seguenti applicazioni:

- Lavorazione con velocità di avanzamento elevate
 - Massimo rendimento nella produzione in serie
 - Materiali duri ed abrasivi
 - Lavorazione a più mandrini
 - Lavorazioni con diametri < 5 mm
-

Utensili con pattini di guida

La prima scelta per le seguenti applicazioni:

- Condizioni macchina instabili
 - Ottimale sul tornio con supporto oscillante
 - Lavorazioni di traversini e componenti con pareti sottili
 - Difficili rapporti tra lunghezza e diametro
 - Tolleranze di forma e posizione estremamente elevate
- 
- 



CARATTERISTICHE DELL'UTENSILE

- Versioni fisse senza oneri di regolazione
- Versioni con regolazione fine ottimizzate per la riaffilatura
- Sistemi a testina intercambiabile ad alta precisione dall'utilizzo semplice e immediato
- Diverse tipologie di prestazione nell'assortimento standard
- Ricondizionamento per un'elevata redditività e convenienza
- Serie selezionata per il magazzino, misura intermedia disponibile in tempi brevi

Con gli alesatori fissi a più taglienti è possibile ridurre drasticamente i tempi di lavorazione. La presenza di più taglienti consente di impiegare valori di avanzamento più elevati, cosa che incide infine sui tempi di lavorazione. Gra

zie a sistemi specifici appositamente sviluppati e alla più moderna tecnologia di produzione, MAPAL garantisce la massima precisione anche per questi utensili.

► [Ulteriori informazioni da pagina 311](#)



CARATTERISTICHE DELL'UTENSILE

- Massima precisione grazie al presettaggio esatto e micrometrico
- Tecnica a inserti ribaltabili per la massima flessibilità nella scelta del materiale da taglio
- Misure intermedie e tutte le tolleranze disponibili in tempi brevi

La tecnologia a pattini di guida MAPAL è ancora ineguagliata nella lavorazione fine di fori in qualsiasi materiale da costruzione. Le precisioni in termini di diametro del foro, di circolarità, di forma cilindrica, nonché di qualità

della superficie, non possono essere ottenute con altri strumenti di lavorazione, o comunque non possono essere ottenute in modo conveniente.

► [Ulteriori informazioni da pagina 477](#)



ALESATORI FISSI A PIÙ TAGLIENTI

Alesatori fissi a più taglienti

Guida per la selezione	312
------------------------------	-----

FixReam FXR

Panoramica prodotti	316
Riepilogo del programma FXR	318
FXR510	322
FXR500	330
FXR505	332
FXR503-short	342
Parametri di lavorazione consigliati	344

MonoReam MOR

Panoramica prodotti	350
Riepilogo del programma MOR/MRP	352
MOR710	356
MOR700	358
MOR705	359
MRP510	362
MRP505	363
Parametri di lavorazione consigliati	364

Alesatori a testina intercambiabile HPR











Panoramica prodotti	368
Riepilogo del programma	370
HPR130	374
HPR131	379
HPR100	383
HPR110	390
HPR180	396
HPR150	405
HPR230	414
HPR231	418
HPR200	422
HPR210	426
HPR280	430
HPR250	438
Parametri di lavorazione consigliati	446
Sovrametallo per alesatura	458
Assortimento supporti	460
Parti di ricambio e accessori	474

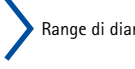

COME SCEGLIERE UN ALESATORE A PIÙ TAGLIENTI

Passo dopo passo verso l'alesatore più giusto

Siete alla ricerca, ad esempio, di un alesatore in metallo duro integrale a più taglienti con diametro 10,000H7 per la lavorazione di un foro cieco in acciaio temprato? La presente guida per la selezione vi condurrà passo dopo passo all'alesatore giusto.

1	Design	Selezionate il design che preferite (monolitico oppure modulare).		Monolitico		Attacco HFS modulare
2	Caratteristiche del foro	Assicuratevi che le caratteristiche della geometria corrispondano ai vostri requisiti. Selezionate il range di diametro e la tolleranza necessaria.		Range di diametro		Tolleranza di foratura raggiungibile \geq IT7
3	Classe di prodotto	Scegliete una classe di prodotto.		Basic Line: utensili universali, vasto campo di applicazione, bassi costi di acquisto		
4	Idoneità del materiale	Stabilite il materiale dei pezzi da lavorare secondo i GTM (gruppi di materiale MAPAL).		Acciaio		Acciaio inossidabile
5	Tipo di foro	Verificate i requisiti che l'utensile deve soddisfare per il tipo di foro.		Foro passante		Foro cieco
6	Prodotto	Selezionate il vostro alesatore. I prodotti della Serie selezionata per il magazzino sono disponibili con un breve preavviso, mentre i prodotti con caratteristiche configurabili sono liberamente configurabili entro limiti predefiniti.		Serie selezionata per il magazzino		Configurazione libera





Performance Line:
utensili ad alte prestazioni, vasto campo di applicazione, elevata produttività nella produzione di serie



Expert Line:
utensili specifici per le applicazioni selezionate, massima precisione e massima produttività



Ghisa



Metalli non ferrosi e materiali sintetici

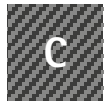

Materiali compositi



Superleghe e titanio



Acciaio temprato e acciaio fuso

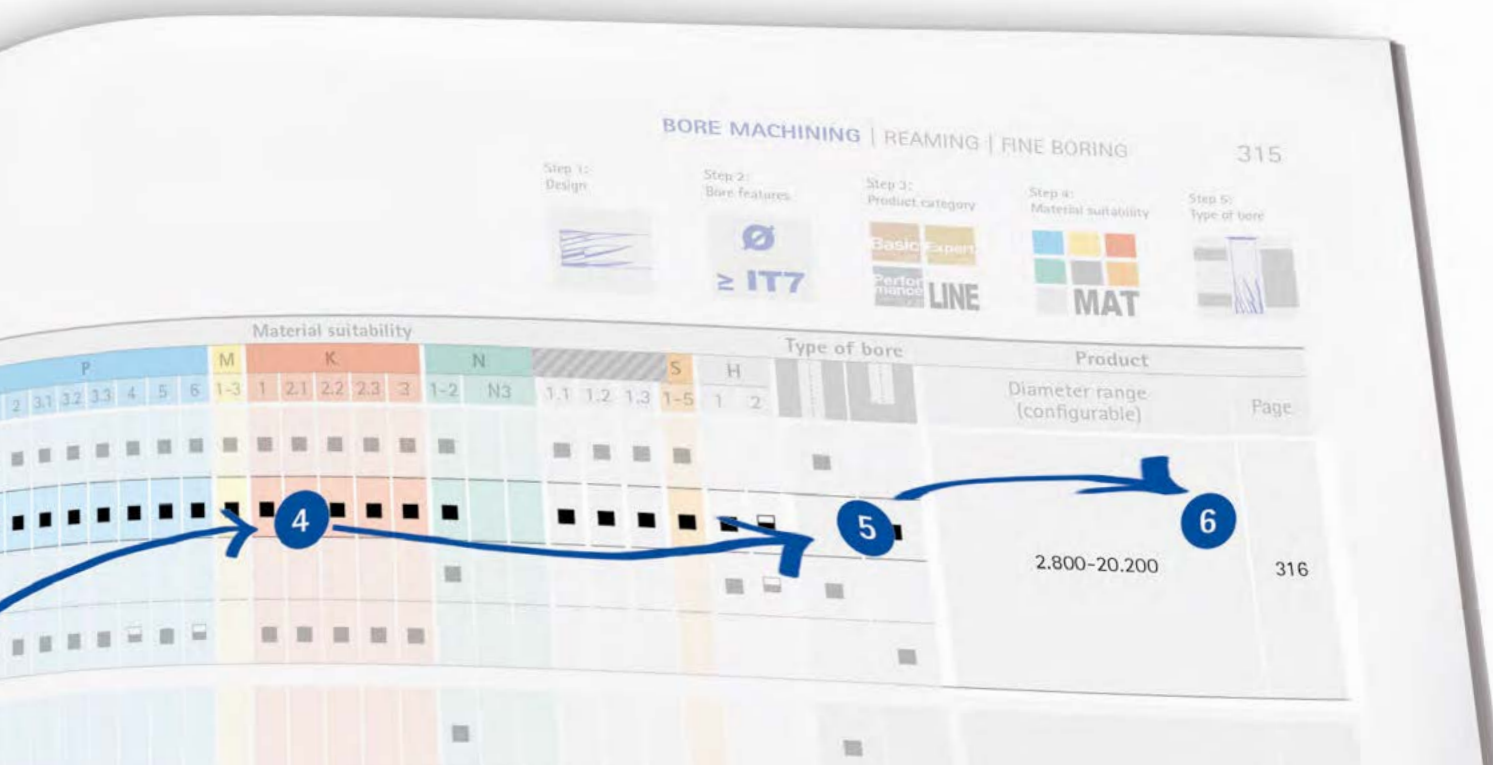



Alesatore | Sistema di selezione

Design	Range di diametro consigliato [mm]	Tolleranza	Serie			Classe di prodotto	
				Diametro	Serie		
	3,000 - 14,000	≥ IT6	FixReam	<p>Alesatore in metallo duro integrale per un vasto campo di applicazioni. A seconda del diametro, gli alesatori ad alte prestazioni FixReam dispongono di taglienti con adduzione interna del refrigerante in numero variabile da quattro a otto, e sono quindi in grado di raggiungere velocità di avanzamento elevate.</p>	2,800 - 20,200*	FXR510	Performance LINE
					2,800 - 20,200*	FXR505	
					3,701 - 20,200*	FXR500	
					2,800 - 20,100*	FXR503	
	14,000 - 40,000	≥ IT6	MonoReam	<p>L'alesatore MOR700 è impiegato come utensile fisso, ma questa serie è stata ottimizzata per la riaffilatura. Tramite un'apposita vite di espansione è possibile ampliare il diametro dell'alesatore.</p>	7,700 - 40,200	MOR700	Performance LINE
						MOR705	
						MOR710	
	4,000 - 8,000	≥ IT6	MonoReam Plus	<p>Specifica per la lavorazione di ghisa e acciaio. Un'apposita boccola assicura un apporto ottimale di refrigerante ai taglienti HPC.</p>	3,850 - 8,200	MRP505	Performance LINE
						MRP510	
	7,000 - 65,000	≥ IT5	HPR	<p>Sistema a testina intercambiabile altamente preciso, in versione fissa e con regolazione fine.</p>	7,000 - 65,000	HPR1XX fisso	Performance LINE Expert LINE
					7,000 - 65,000	HPR2XX con regolazione fine	
	63,000 - 319,999	≥ IT7	HPR 400 400 plus	<p>Grazie ai taglienti intercambiabili, il cambio può essere effettuato semplicemente in loco. I tempi di messa a punto risultano notevolmente ridotti.</p>	63,000 - 319,999	HPR400 400 plus	Expert LINE

* Il range di diametro può variare a seconda della serie.

Fase 1:
Design



Fase 2:
Caratteristiche del
foro



Fase 3:
Classe di prodotto



Fase 4:
Idoneità del
materiale



Fase 5:
Tipo di foro



	Idoneità del materiale														Tipo di foro						Prodotto								
	P							M	K					N		C			S	H		Range di diametro (configurabile)	Pagina						
	1	2	3.1	3.2	3.3	4	5	6	1-3	1	2.1	2.2	2.3	3	1-2	N3	1.1	1.2	1.3	1-5	1			2					
	■	■	■	■	■	■	■	■	■	■	■	■	■	■		■	■	■	■			■	■			2,800-20,200*	316		
	■	■	■	■	■	■	■	■	■	■	■	■	■	■		■	■	■	■	■	■		■						
														■						■	■	■							
	■	■	■	■	■	■	■		■	■	■	■	■										■						
														■	■								■			7,700-40,200	350		
	■	■	■	■	■	■	■		■	■	■	■	■	■	■								■						
	■	■	■	■	■	■	■		■	■	■	■	■										■						
	■	■	■	■					■	■													■			3,850-8,200	350		
	■	■	■	■					■	■													■						
	■	■	■	■	■	■	■	■	■	■	■	■	■	■					■			■	■			7,000-65,000	368		
	■	■	■	■	■	■	■	■	■	■	■	■	■	■					■			■	■						
	■	■	■	■	■	■	■	■	■	■	■	■	■	■									■	■			63,000-319,999	562	

PANORAMICA PRODOTTI

FixReam: FXR500 | FXR510 | FXR505 | FXR503

Le serie di alesatori ad alte prestazioni FXR in metallo duro integrabile copre un vasto spettro di applicazioni. A seconda del diametro, gli alesatori ad alte prestazioni FixReam dispongono di taglienti con adduzione interna del refrigerante in numero variabile da quattro a otto, e sono quindi in grado di raggiungere velocità di avanzamento elevate. Grazie all'impiego di diversi materiali da taglio e di svariati rivestimenti è possibile lavorare in modo conveniente e con processi sicuri numerosi materiali in un range di diametro da 2,850 a 20,200 mm* nel campo di tolleranza IT7 senza necessità di regolazione.

Per l'impiego in condizioni di ridotta disponibilità di spazio, ad esempio in caso di utilizzo su torni automatici, sono disponibili versioni "short" più corte.



FixReam



FixReam | FXR500 metallo duro integrale

Alesatori ad alte prestazioni a scanalatura dritta, con adduzione interna del refrigerante, in metallo duro integrale. Come serie selezionata in H7.

Serie selezionata range di \varnothing : 3.701 - 20.200 mm*



FixReam | FXR510 metallo duro integrale

Alesatori ad alte prestazioni con scanalatura obliqua sinistra, con adduzione interna del refrigerante, in metallo duro integrale. Come serie selezionata in H7.

Serie selezionata range di \varnothing : 2,800 - 20,200 mm*





FixReam | FXR505 metallo duro integrale

Alesatori ad alte prestazioni a scanalatura dritta, con adduzione interna del refrigerante, in metallo duro integrale. Come serie selezionata in H7.

Serie selezionata range di \varnothing : 2,800 - 20,200 mm*

Perfor
mance
LINE



P M K N C S H



FixReam | FXR503-short metallo duro integrale

Alesatore extra corto ad alte prestazioni in metallo duro massiccio, appositamente progettato per l'uso su torni automatici. Come serie selezionata in H7.

Serie selezionata range di \varnothing : 2,800 - 20,100 mm*

Perfor
mance
LINE



P K

Riepilogo del programma FixReam (1/2)

Classe di prodotto	Tipo di foro	Idoneità del materiale												
		P				M	K	N			C	S	H	
		1-3	4	5	6	1-3	1-3	1	2	4	1	1-5	1	2
Performance TUNE		■	■	■	■		■							
			■		■	■								
								■						
								■	■	■				
		■	■	■	■		■							
		■	■	■	■		■							
			■		■	■								
								■	■	■				
		■	■	■	■		■							
		■	■	■	■		■							
			■		■	■								
								■	■	■				
		■	■	■	■		■							
		■	■	■	■		■							
			■		■	■								
								■	■	■				

Esempio di ordine:

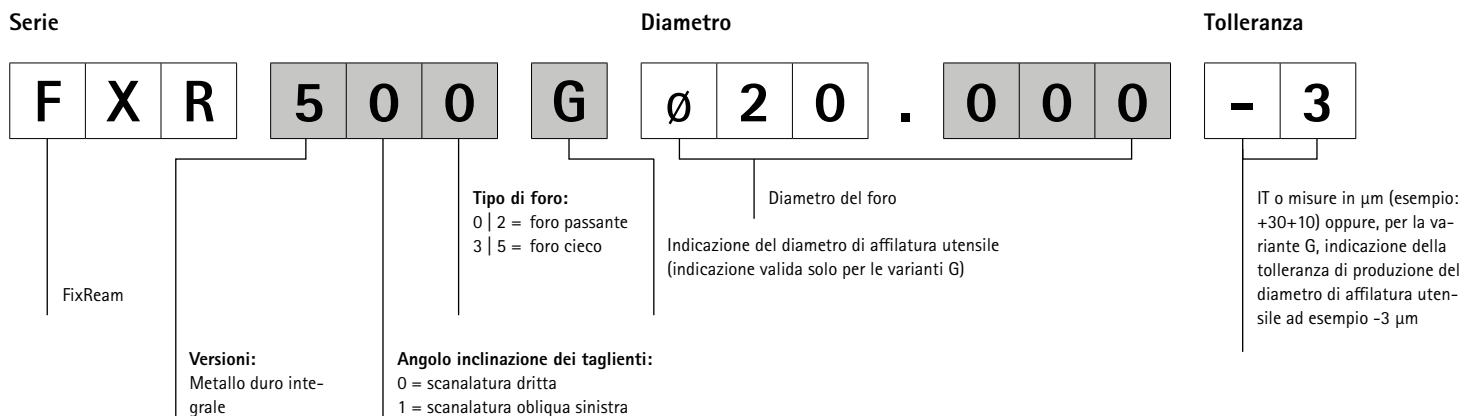

Fase 1:
Classe di prodottoFase 2:
Tipo di foroFase 3:
Idoneità del materialeFase 4:
VersioneFase 5:
Diametri preconfigurati o configurazione

	Versione					Diametri preconfigurati		Configurazione
	d1	Materiale da taglio	Imbocco			Serie	Pagina	
	2,800-20,200	HP145	MG1M			FXR510	322	FXR510 Versione fissa con scanalatura obliqua sinistra, per foro passante
	3,701-20,200	HP145	MF1M			FXR510	326	
	3,701-20,200	HP622	MG0A			FXR500	330	
	2,800-20,200	HU612	MG1M			FXR510	324	
	3,701-20,200	HC614	MF1M			FXR510	329	FXR500 Versione fissa con scanalatura dritta, per foro passante
	3,701-20,200	HP625	MF1M			FXR510	328	
	3,701-20,200	HP141	MFOA			FXR500	331	
	2,800-20,200	HP145	MV0A			FXR505	332	FXR505 Versione fissa con scanalatura dritta, per foro cieco
	2,800-20,100	HP145	MC1F			FXR503	342	
	3,701-20,200	HP145	MT0A			FXR505	334	
	3,701-20,200	HP622	MV0A			FXR505	335	
	2,800-20,200	HU612	MV0A			FXR505	336	
	3,701-20,200	HC614	MV0A			FXR505	339	
	3,701-20,200	HP625	MT0A			FXR505	338	FXR503-short Versione fissa con scanalatura dritta, per foro cieco
	3,701-20,200	HP141	MT0A			FXR505	340	

Configurazione serie alla pagina seguente.

Imbocco [Lead]

Materiale da taglio [Cut]

M	G	O	A	-	H	P	6	2	2
---	---	---	---	---	---	---	---	---	---

Forma di imbocco e angolo di spoglia:

MG0A	MT0A	Per la spiegazione delle geometrie di imbocco vedere pagina 752
MG1M	MFOA	
MF1M	MC1F	
MV0A		

Materiale da taglio:

HP145	HP141
HU612	HP625
HP622	
HC614	

Riepilogo del programma FixReam | Configurazione (2/2)

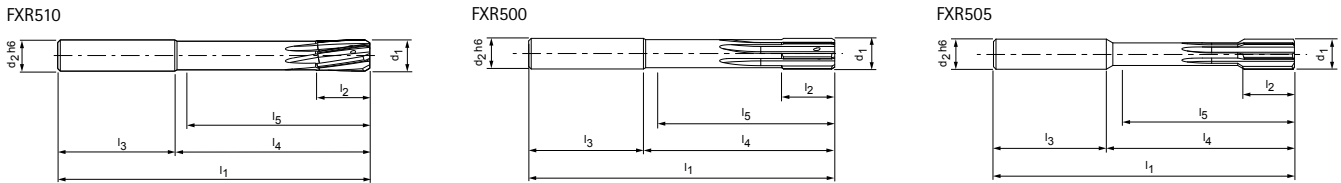

Misure utensili

FXR510

d ₁	d ₂	l ₁	l ₂	l ₃	l ₄	l ₅	z
2,800 - 3,700	4	65	12	28	37	34	4
3,701 - 4,700	6	75	12	36	39	34	4
4,701 - 6,200	6	75	12	36	39	35	4
6,201 - 7,200	8	100	16	36	64	59	6
7,201 - 8,200	8	100	16	36	64	60	6
8,201 - 9,200	10	100	20	40	60	55	6
9,201 - 10,200	10	120	20	40	80	76	6
10,201 - 11,200	12	120	20	45	75	70	6
11,201 - 12,200	12	120	20	45	75	71	6
12,201 - 14,200	14	130	22	45	85	80	6
14,201 - 15,200	16	130	22	48	82	77	6
15,201 - 16,200	16	150	25	48	102	97	6
16,201 - 18,200	18	150	25	48	102	97	8
18,201 - 20,200	20	150	25	50	100	95	8

FXR505

d ₁	d ₂	l ₁	l ₂	l ₃	l ₄	l ₅	z
2,800 - 3,350	4	65	12	37	28	33	4
3,351 - 3,700	4	65	12	28	37	33	4
3,701 - 6,200	6	75	12	36	39	34	4
6,201 - 8,200	8	100	16	36	64	58	6
8,201 - 9,200	10	100	20	40	60	54	6
9,201 - 10,200	10	120	20	40	80	74	6
10,201 - 12,200	12	120	20	45	75	68	6
12,201 - 14,200	14	130	22	45	85	78	6
14,201 - 15,200	16	130	22	48	82	75	6
15,201 - 16,200	16	150	25	48	102	95	6
16,201 - 18,200	18	150	25	48	102	95	6
18,201 - 20,200	20	150	25	50	100	92	6

Tolleranze per la variante G/variante fissa FXR5XX:

Materiale da taglio	Range di diametro
	Ø2,800 - 20,200
Non rivestito	-0,003
HU612	
Rivestito (spessore strato 0,8 - 2 µm)	-0,004
HP145	
HP625	
HP622	
HC614	-0,005
Rivestito (spessore strato 2 - 4 µm)	
HP141	

Spiegazione variante G FXR

Tolleranze ammesse sul pezzo per la selezione del diametro utensile

Versione variante G:

La variante G indica il diametro dell'utensile dell'alesatore con le nostre tolleranze di produzione. Le tolleranze di produzione dipendono dal materiale da taglio, si vedano le tolleranze minime ammesse per la variante G.

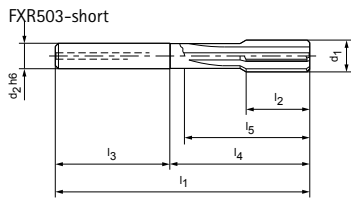

FXR500

d_1	d_2	l_1	l_2	l_3	l_4	l_5	z
3,701 - 4,700	6	75	12	36	39	34	4
4,701 - 6,200	6	75	12	36	39	35	4
6,201 - 7,200	8	100	16	36	64	59	6
7,201 - 8,200	8	100	16	36	64	60	6
8,201 - 9,200	10	100	20	40	60	55	6
9,201 - 10,200	10	120	20	40	80	76	6
10,201 - 11,200	12	120	20	45	75	70	6
11,201 - 12,200	12	120	20	45	75	71	6
12,201 - 14,200	14	130	22	45	85	80	6
14,201 - 15,200	16	130	22	48	82	77	6
15,201 - 16,200	16	150	25	48	102	97	6
16,201 - 18,200	18	150	25	48	102	97	8
18,201 - 20,200	20	150	25	50	100	95	8

FXR503-short

d_1	d_2	l_1	l_2	l_3	l_4	l_5	z
2,800 - 4,050	4	56	12	28	28	24	4
4,051 - 5,100	6	64	12	36	28	23	4
5,101 - 5,600	6	64	12	36	28	24	4
6,101 - 6,600	8	75	16	36	39	32	6
6,601 - 7,100	8	75	16	36	39	34	6
7,101 - 8,100	8	75	16	36	39	35	6
8,101 - 10,100	8	75	20	36	39	35	6
10,101 - 11,600	10	80	20	40	40	35	6
11,601 - 13,100	12	90	22	45	45	40	6
13,101 - 15,100	14	90	22	45	45	40	6
15,101 - 18,100	16	100	25	48	52	47	8
18,101 - 20,100	18	100	25	48	52	47	8



Soluzioni speciali personalizzate
per la lavorazione in più fasi.

FixReam

Versione fissa con scanalatura obliqua sinistra, per foro passante
FXR510

Versione:

Diametro alesatore:

2,800 - 20,200 mm

Imbocco:

MG1M

Materiale da taglio:

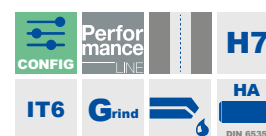
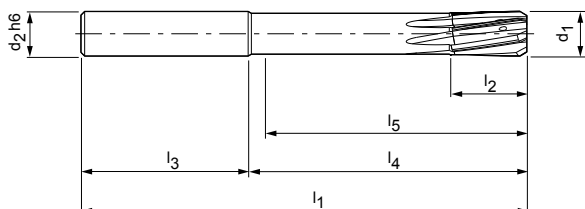
 HP145
 metallo duro rivestito
 in PVD

Serie selezionata per il magazzino in H7

d ₁ H7	Dimensioni						z	Specifiche	Codice
	d ₂ h6	l ₁	l ₂	l ₃	l ₄	l ₅			
4,000	6	75	12	36	39	34	4	FXR510Ø4.000H7MG1M-HP145	30570722
5,000	6	75	12	36	39	35	4	FXR510Ø5.000H7MG1M-HP145	30570724
6,000	6	75	12	36	39	35	4	FXR510Ø6.000H7MG1M-HP145	30570726
7,000	8	100	16	36	64	59	6	FXR510Ø7.000H7MG1M-HP145	30570728
8,000	8	100	16	36	64	60	6	FXR510Ø8.000H7MG1M-HP145	30570730
9,000	10	100	20	40	60	55	6	FXR510Ø9.000H7MG1M-HP145	30570732
10,000	10	120	20	40	80	76	6	FXR510Ø10.000H7MG1M-HP145	30570734
11,000	12	120	20	45	75	70	6	FXR510Ø11.000H7MG1M-HP145	30570736
12,000	12	120	20	45	75	71	6	FXR510Ø12.000H7MG1M-HP145	30570738
13,000	14	130	22	45	85	80	6	FXR510Ø13.000H7MG1M-HP145	30570739
14,000	14	130	22	45	85	80	6	FXR510Ø14.000H7MG1M-HP145	30570740
15,000	16	130	22	48	82	77	6	FXR510Ø15.000H7MG1M-HP145	30570741
16,000	16	150	25	48	102	97	6	FXR510Ø16.000H7MG1M-HP145	30570742
17,000	18	150	25	48	102	97	8	FXR510Ø17.000H7MG1M-HP145	30570743
18,000	18	150	25	48	102	97	8	FXR510Ø18.000H7MG1M-HP145	30570744
19,000	20	150	25	50	100	95	8	FXR510Ø19.000H7MG1M-HP145	30570745

Misure in mm.

Per i parametri di lavorazione consigliati, vedere la fine del capitolo.

FXR510 | Versione fissa, con scanalatura obliqua sinistra

Caratteristiche configurabili

**Diametro del foro tolleranza \geq IT6:**

- Diametro a libera scelta a passi da 0,001 mm
- Ordinabile in tolleranza \geq IT6

**Specifiche:**

FXR510Ø[diametro][tolleranza]MG1M-HP145

Variante G:

- Diametro a libera scelta a passi da 0,001 mm
- Ordinabile a partire da una tolleranza $\geq 4 \mu\text{m}$ (variante G vedere pagina 320)

Specifiche variante G:

FXR510GØ[diametro][tolleranza]MG1M-HP145

Dimensioni serie configurabile IT6

d_1	d_2	l_1	l_2	l_3	l_4	l_5	z
2,800 - 3,700	4	65	12	28	37	34	4
3,701 - 4,700	6	75	12	36	39	34	4
4,701 - 6,200	6	75	12	36	39	35	4
6,201 - 7,200	8	100	16	36	64	59	6
7,201 - 8,200	8	100	16	36	64	60	6
8,201 - 9,200	10	100	20	40	60	55	6
9,201 - 10,200	10	120	20	40	80	76	6
10,201 - 11,200	12	120	20	45	75	70	6
11,201 - 12,200	12	120	20	45	75	71	6
12,201 - 14,200	14	130	22	45	85	80	6
14,201 - 15,200	16	130	22	48	82	77	6
15,201 - 16,200	16	150	25	48	102	97	6
16,201 - 18,200	18	150	25	48	102	97	8
18,201 - 20,200	20	150	25	50	100	95	8

Esempio tolleranza IT6:

FXR510Ø16.350H6MG1M-HP145

Diametro del foro $d_1 = 16,350 \text{ H6}$ **Esempio variante G:**

FXR510GØ16.350-4MG1M-HP145

Diametro utensile speciale $d_1 = 16,350 -4 \mu\text{m}$

FixReam

Versione fissa con scanalatura obliqua sinistra, per foro passante
FXR510

Versione:

Diametro alesatore:

2,800 - 20,200 mm

Imbocco:

MG1M

Materiale da taglio:

HU612

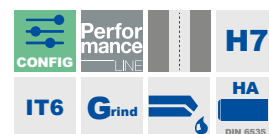
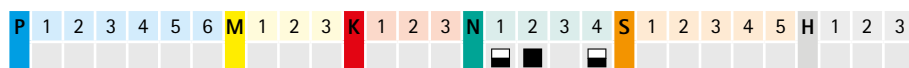
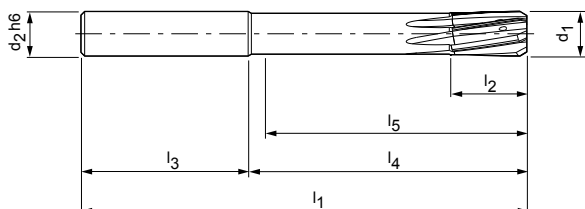
 Metallo duro non
rivestito

Serie selezionata per il magazzino in H7

d ₁ H7	Dimensioni						z	Specifiche	Codice
	d ₂ h6	l ₁	l ₂	l ₃	l ₄	l ₅			
4,000	6	75	12	36	39	34	4	FXR510Ø4.000H7MG1M-HU612	30570665
5,000	6	75	12	36	39	35	4	FXR510Ø5.000H7MG1M-HU612	30570667
6,000	6	75	12	36	39	35	4	FXR510Ø6.000H7MG1M-HU612	30570669
7,000	8	100	16	36	64	59	6	FXR510Ø7.000H7MG1M-HU612	30570671
8,000	8	100	16	36	64	60	6	FXR510Ø8.000H7MG1M-HU612	30570673
9,000	10	100	20	40	60	55	6	FXR510Ø9.000H7MG1M-HU612	30570675
10,000	10	120	20	40	80	76	6	FXR510Ø10.000H7MG1M-HU612	30570677
11,000	12	120	20	45	75	70	6	FXR510Ø11.000H7MG1M-HU612	30570679
12,000	12	120	20	45	75	71	6	FXR510Ø12.000H7MG1M-HU612	30570682
13,000	14	130	22	45	85	80	6	FXR510Ø13.000H7MG1M-HU612	30570683
14,000	14	130	22	45	85	80	6	FXR510Ø14.000H7MG1M-HU612	30570684
15,000	16	130	22	48	82	77	6	FXR510Ø15.000H7MG1M-HU612	30570685
16,000	16	150	25	48	102	97	6	FXR510Ø16.000H7MG1M-HU612	30570686
17,000	18	150	25	48	102	97	8	FXR510Ø17.000H7MG1M-HU612	30570687
18,000	18	150	25	48	102	97	8	FXR510Ø18.000H7MG1M-HU612	30570688

Misure in mm.

Per i parametri di lavorazione consigliati, vedere la fine del capitolo.

FXR510 | Versione fissa, con scanalatura obliqua sinistra

Caratteristiche configurabili

**Diametro del foro tolleranza \geq IT6:**

- Diametro a libera scelta a passi da 0,001 mm
- Ordinabile in tolleranza \geq IT6

**Specifiche:**

FXR510Ø[diametro][tolleranza]MG1M-HU612

Variante G:

- Diametro a libera scelta a passi da 0,001 mm
- Ordinabile a partire da una tolleranza $\geq 3 \mu\text{m}$ (variante G vedere pagina 320)

Specifiche variante G:

FXR510GØ[diametro][tolleranza]MG1M-HU612

Dimensioni serie configurabile IT6

d_1	d_2	l_1	l_2	l_3	l_4	l_5	z
2,800 - 3,700	4	65	12	28	37	34	4
3,701 - 4,700	6	75	12	36	39	34	4
4,701 - 6,200	6	75	12	36	39	35	4
6,201 - 7,200	8	100	16	36	64	59	6
7,201 - 8,200	8	100	16	36	64	60	6
8,201 - 9,200	10	100	20	40	60	55	6
9,201 - 10,200	10	120	20	40	80	76	6
10,201 - 11,200	12	120	20	45	75	70	6
11,201 - 12,200	12	120	20	45	75	71	6
12,201 - 14,200	14	130	22	45	85	80	6
14,201 - 15,200	16	130	22	48	82	77	6
15,201 - 16,200	16	150	25	48	102	97	6
16,201 - 18,200	18	150	25	48	102	97	8
18,201 - 20,200	20	150	25	50	100	95	8

Esempio tolleranza IT6:

FXR510Ø16.350H6MG1M-HU612

Diametro del foro $d_1 = 16,350 \text{ H6}$ **Esempio variante G:**

FXR510GØ16.350-3MG1M-HU612

Diametro utensile speciale $d_1 = 16,350 -3 \mu\text{m}$

FixReam

Versione fissa con scanalatura obliqua sinistra, per foro passante
FXR510

Versione:

Diametro alesatore:

3,701 - 20,200 mm

Imbocco:

MF1M

Materiale da taglio:

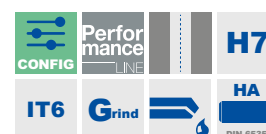
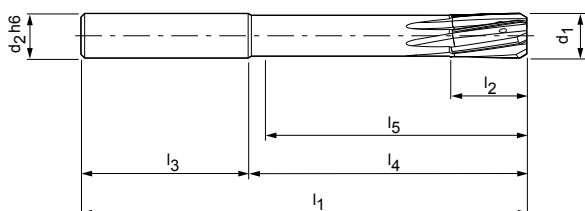
 HP145
 metallo duro rivestito
 in PVD

Serie selezionata per il magazzino in H7

d ₁ H7	Dimensioni						z	Specifiche	Codice
	d ₂ h6	l ₁	l ₂	l ₃	l ₄	l ₅			
4,000	6	75	12	36	39	35	4	FXR510Ø4.000H7MF1M-HP145	30570772
5,000	6	75	12	36	39	35	4	FXR510Ø5.000H7MF1M-HP145	30570774
6,000	6	75	12	36	39	35	4	FXR510Ø6.000H7MF1M-HP145	30570776
7,000	8	100	16	36	64	59	6	FXR510Ø7.000H7MF1M-HP145	30570778
8,000	8	100	16	36	64	60	6	FXR510Ø8.000H7MF1M-HP145	30570780
10,000	10	120	20	40	80	76	6	FXR510Ø10.000H7MF1M-HP145	30570784
11,000	12	120	20	45	75	70	6	FXR510Ø11.000H7MF1M-HP145	30570786
12,000	12	120	20	45	75	71	6	FXR510Ø12.000H7MF1M-HP145	30570788
14,000	14	130	22	45	85	80	6	FXR510Ø14.000H7MF1M-HP145	30570790
16,000	16	150	25	48	102	97	6	FXR510Ø16.000H7MF1M-HP145	30570792

Misure in mm.

Per i parametri di lavorazione consigliati, vedere la fine del capitolo.

FXR510 | Versione fissa, con scanalatura obliqua sinistra

Caratteristiche configurabili

**Diametro del foro tolleranza \geq IT6:**

- Diametro a libera scelta a passi da 0,001 mm
- Ordinabile in tolleranza \geq IT6

**Specifiche:**

FXR510Ø[diametro][tolleranza]MF1M-HP145

Variante G:

- Diametro a libera scelta a passi da 0,001 mm
- Ordinabile a partire da una tolleranza $\geq 4 \mu\text{m}$ (variante G vedere pagina 320)

Specifiche variante G:

FXR510GØ[diametro][tolleranza]MF1M-HP145

Dimensioni serie configurabile IT6

d_1	d_2	l_1	l_2	l_3	l_4	l_5	z
3,701 - 4,700	6	75	12	36	39	34	4
4,701 - 6,200	6	75	12	36	39	35	4
6,201 - 7,200	8	100	16	36	64	59	6
7,201 - 8,200	8	100	16	36	64	60	6
8,201 - 9,200	10	100	20	40	60	55	6
9,201 - 10,200	10	120	20	40	80	76	6
10,201 - 11,200	12	120	20	45	75	70	6
11,201 - 12,200	12	120	20	45	75	71	6
12,201 - 14,200	14	130	22	45	85	80	6
14,201 - 15,200	16	130	22	48	82	77	6
15,201 - 16,200	16	150	25	48	102	97	6
16,201 - 18,200	18	150	25	48	102	97	8
18,201 - 20,200	20	150	25	50	100	95	8

Esempio tolleranza IT6:

FXR510Ø16.350H6MF1M-HP145

Diametro del foro $d_1 = 16,350 \text{ H6}$ **Esempio variante G:**

FXR510GØ16.350-4MF1M-HP145

Diametro utensile speciale $d_1 = 16,350 -4 \mu\text{m}$

FixReam

Versione fissa con scanalatura obliqua sinistra, per foro passante
FXR510

Versione:

Diametro alesatore:

3,701 - 20,200 mm

Imbocco:

MF1M

Materiale da taglio:

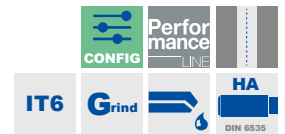
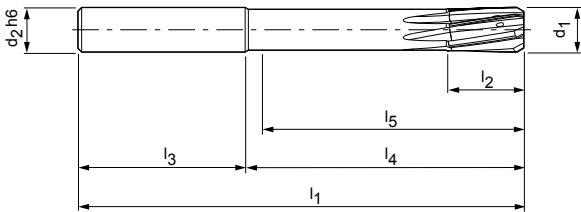
 HP625
 metallo duro rivestito
 in PVD

Caratteristiche configurabili

Diametro del foro tolleranza \geq IT6:

- Diametro a libera scelta a passi da 0,001 mm
- Ordinabile in tolleranza \geq IT6

Specifiche:

FXR510Ø[diametro][tolleranza]MF1M-HP625

Variante G:

- Diametro a libera scelta a passi da 0,001 mm
- Ordinabile a partire da una tolleranza \geq 4 μ m (variante G vedere pagina 320)

Specifiche variante G:

FXR510GØ[diametro][tolleranza]MF1M-HP625

Dimensioni serie configurabile IT6

d_1	d_2	l_1	l_2	l_3	l_4	l_5	z
3,701 - 4,700	6	75	12	36	39	34	4
4,701 - 6,200	6	75	12	36	39	35	4
6,201 - 7,200	8	100	16	36	64	59	6
7,201 - 8,200	8	100	16	36	64	60	6
8,201 - 9,200	10	100	20	40	60	55	6
9,201 - 10,200	10	120	20	40	80	76	6
10,201 - 11,200	12	120	20	45	75	70	6
11,201 - 12,200	12	120	20	45	75	71	6
12,201 - 14,200	14	130	22	45	85	80	6
14,201 - 15,200	16	130	22	48	82	77	6
15,201 - 16,200	16	150	25	48	102	97	6
16,201 - 18,200	18	150	25	48	102	97	8
18,201 - 20,200	20	150	25	50	100	95	8

Esempio tolleranza IT6:

FXR510Ø16.350H6MF1M-HP625

 Diametro del foro $d_1 = 16,350$ H6

Esempio variante G:

FXR510GØ16.350-4MF1M-HP625

 Diametro utensile speciale $d_1 = 16,350 -4 \mu$ m

Misure in mm.

Per i parametri di lavorazione consigliati, vedere la fine del capitolo.

FixReam

Versione fissa con scanalatura obliqua sinistra, per foro passante
FXR510

Versione:

Diametro alesatore:

3,701 - 20,200 mm

Imbocco:

MF1M

Materiale da taglio:

HC614

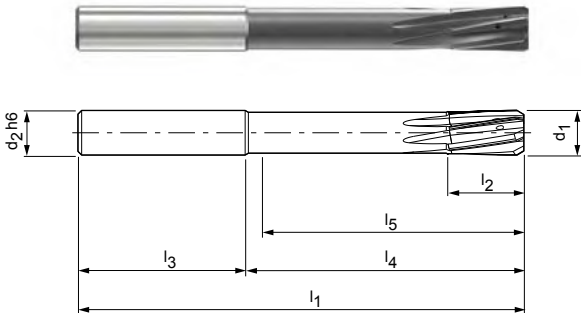
 Metallo duro rivestito
in CVD

N	1.1	1.2	1.3	1.4	2.1	2.2	2.3	3.1	4.1	4.2	4.3	C	1.1	1.2	1.3	2.1	3.1	4.1	4.2	4.3	4.4	5.1	5.2
---	-----	-----	-----	-----	-----	-----	-----	-----	-----	-----	-----	---	-----	-----	-----	-----	-----	-----	-----	-----	-----	-----	-----

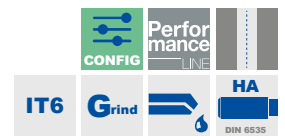
Caratteristiche configurabili

Diametro del foro tolleranza \geq IT6:

- Diametro a libera scelta a passi da 0,001 mm
- Ordinabile in tolleranza \geq IT6

Specifiche:

FXR510Ø[diametro][tolleranza]MF1M-HC614

Variante G:

- Diametro a libera scelta a passi da 0,001 mm
- Ordinabile a partire da una tolleranza \geq 4 μ m (variante G vedere pagina 320)

Specifiche variante G:

FXR510GØ[diametro][tolleranza]MF1M-HC614

Dimensioni serie configurabile IT6

d_1	d_2	l_1	l_2	l_3	l_4	l_5	z
3,701 - 4,700	6	75	12	36	39	34	4
4,701 - 6,200	6	75	12	36	39	35	4
6,201 - 7,200	8	100	16	36	64	59	6
7,201 - 8,200	8	100	16	36	64	60	6
8,201 - 9,200	10	100	20	40	60	55	6
9,201 - 10,200	10	120	20	40	80	76	6
10,201 - 11,200	12	120	20	45	75	70	6
11,201 - 12,200	12	120	20	45	75	71	6
12,201 - 14,200	14	130	22	45	85	80	6
14,201 - 15,200	16	130	22	48	82	77	6
15,201 - 16,200	16	150	25	48	102	97	6
16,201 - 18,200	18	150	25	48	102	97	8
18,201 - 20,200	20	150	25	50	100	95	8

Esempio tolleranza IT6:

FXR510Ø16.350H6MF1M-HC614

 Diametro del foro $d_1 = 16,350$ H6

Esempio variante G:

FXR510GØ16.350-4MF1M-HC614

 Diametro utensile speciale $d_1 = 16,350 -4 \mu$ m

Misure in mm.

Per i parametri di lavorazione consigliati, vedere la fine del capitolo.

FixReam

Versione fissa con scanalatura dritta, per foro passante
FXR500

Versione:

Diametro alesatore:

3,701 - 20,200 mm

Imbocco:

MG0A

Materiale da taglio:

HP622
metallo duro rivestito
in PVD

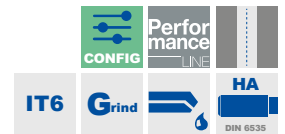
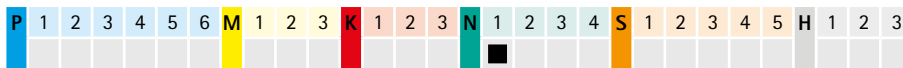
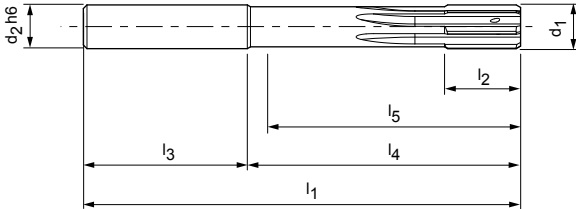

Caratteristiche configurabili



Diametro del foro tolleranza \geq IT6:

- Diametro a libera scelta a passi da 0,001 mm
- Ordinabile in tolleranza \geq IT6

Specifiche:

FXR500Ø[diametro][tolleranza]MG0A-HP622

Variante G:

- Diametro a libera scelta a passi da 0,001 mm
- Ordinabile a partire da una tolleranza \geq 4 μ m (variante G vedere pagina 320)

Specifiche variante G:

FXR500GØ[diametro][tolleranza]MG0A-HP622

Dimensioni serie configurabile IT6

d ₁	d ₂	l ₁	l ₂	l ₃	l ₄	l ₅	z
3,701 - 4,700	6	75	12	36	39	34	4
4,701 - 6,200	6	75	12	36	39	35	4
6,201 - 7,200	8	100	16	36	64	59	6
7,201 - 8,200	8	100	16	36	64	60	6
8,201 - 9,200	10	100	20	40	60	55	6
9,201 - 10,200	10	120	20	40	80	76	6
10,201 - 11,200	12	120	20	45	75	70	6
11,201 - 12,200	12	120	20	45	75	71	6
12,201 - 14,200	14	130	22	45	85	80	6
14,201 - 15,200	16	130	22	48	82	77	6
15,201 - 16,200	16	150	25	48	102	97	6
16,201 - 18,200	18	150	25	48	102	97	8
18,201 - 20,200	20	150	25	50	100	95	8

Esempio tolleranza IT6:

FXR500Ø16.350H6MG0A-HP622

Diametro del foro d₁ = 16,350 H6

Esempio variante G:

FXR500GØ16.350-4MG0A-HP622

Diametro utensile speciale d₁ = 16,350 -4 μ m

Misure in mm.

Per i parametri di lavorazione consigliati, vedere la fine del capitolo.

FixReam

Versione fissa con scanalatura dritta, per foro passante
FXR500

Versione:

Diametro alesatore:

3,701 - 20,200 mm

Imbocco:

MF0A

Materiale da taglio:

HP141

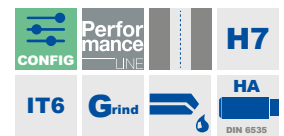
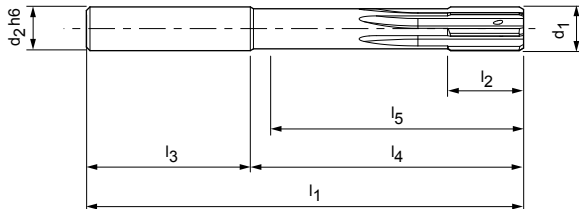
 metallo duro rivestito
in PVD

Serie selezionata per il magazzino in H7

d ₁ H7	Dimensioni						z	Specifiche	Codice
	d ₂ h6	l ₁	l ₂	l ₃	l ₄	l ₅			
5,000	6	75	12	36	39	35	4	FXR500Ø5.000H7MF0A-HP141	30570824
6,000	6	75	12	36	39	35	4	FXR500Ø6.000H7MF0A-HP141	30570826
8,000	8	100	16	36	64	60	6	FXR500Ø8.000H7MF0A-HP141	30570830
10,000	10	120	20	40	80	76	6	FXR500Ø10.000H7MF0A-HP141	30570834
12,000	12	120	20	45	75	71	6	FXR500Ø12.000H7MF0A-HP141	30570838

Caratteristiche configurabili

Diametro del foro tolleranza ≥ IT6:

- Diametro a libera scelta a passi da 0,001 mm
- Ordinabile in tolleranza ≥ IT6

Specifiche:

FXR500Ø[diametro][tolleranza]MF0A-HP141

Variante G:

- Diametro a libera scelta a passi da 0,001 mm
- Ordinabile a partire da una tolleranza ≥ 5 µm (variante G vedere pagina 320)

Specifiche variante G:

FXR500GØ[diametro][tolleranza]MF0A-HP141

Dimensioni serie configurabile IT6

d ₁	d ₂	l ₁	l ₂	l ₃	l ₄	l ₅	z
3,701 - 4,700	6	75	12	36	39	34	4
4,701 - 6,200	6	75	12	36	39	35	4
6,201 - 7,200	8	100	16	36	64	59	6
7,201 - 8,200	8	100	16	36	64	60	6
8,201 - 9,200	10	100	20	40	60	55	6
9,201 - 10,200	10	120	20	40	80	76	6
10,201 - 11,200	12	120	20	45	75	70	6
11,201 - 12,200	12	120	20	45	75	71	6
12,201 - 14,200	14	130	22	45	85	80	6
14,201 - 15,200	16	130	22	48	82	77	6
15,201 - 16,200	16	150	25	48	102	97	6
16,201 - 18,200	18	150	25	48	102	97	8
18,201 - 20,200	20	150	25	50	100	95	8

Esempio tolleranza IT6:

FXR500Ø16.350H6MF0A-HP141

 Diametro del foro d₁ = 16,350 H6

Esempio variante G:

FXR500GØ16.350-5MF0A-HP141

 Diametro utensile speciale d₁ = 16,350 -5 µm

Misure in mm.

Per i parametri di lavorazione consigliati, vedere la fine del capitolo.

FixReam

Versione fissa con scanalatura dritta, per foro cieco
FXR505

Versione:

Diametro alesatore:

2,800 - 20,200 mm

Imbocco:

HP145

Materiale da taglio:

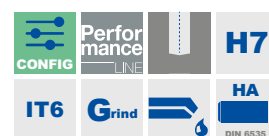
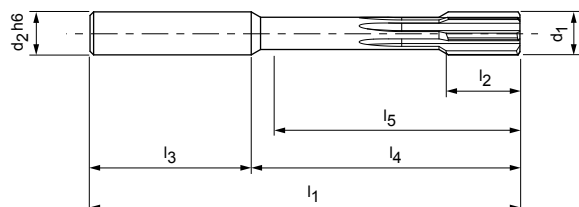
 metallo duro rivestito
in PVD

Serie selezionata per il magazzino in H7

d ₁ H7	Dimensioni						z	Specifiche	Codice
	d ₂ h6	l ₁	l ₂	l ₃	l ₄	l ₅			
4,000	6	75	12	36	39	34	4	FXR505Ø4.000H7MV0A-HP145	30570747
5,000	6	75	12	36	39	34	4	FXR505Ø5.000H7MV0A-HP145	30570749
6,000	6	75	12	36	39	34	4	FXR505Ø6.000H7MV0A-HP145	30570751
7,000	8	100	16	36	64	58	6	FXR505Ø7.000H7MV0A-HP145	30570753
8,000	8	100	16	36	64	58	6	FXR505Ø8.000H7MV0A-HP145	30570755
9,000	10	100	20	40	60	54	6	FXR505Ø9.000H7MV0A-HP145	30570757
10,000	10	120	20	40	80	74	6	FXR505Ø10.000H7MV0A-HP145	30570759
11,000	12	120	20	45	75	68	6	FXR505Ø11.000H7MV0A-HP145	30570761
12,000	12	120	20	45	75	68	6	FXR505Ø12.000H7MV0A-HP145	30570763
13,000	14	130	22	45	85	78	6	FXR505Ø13.000H7MV0A-HP145	30570764
14,000	14	130	22	45	85	78	6	FXR505Ø14.000H7MV0A-HP145	30570765
15,000	16	130	22	48	82	75	6	FXR505Ø15.000H7MV0A-HP145	30570766
16,000	16	150	25	48	102	95	6	FXR505Ø16.000H7MV0A-HP145	30570767
17,000	18	150	25	48	102	95	6	FXR505Ø17.000H7MV0A-HP145	30570768
18,000	18	150	25	48	102	95	6	FXR505Ø18.000H7MV0A-HP145	30570769
19,000	20	150	25	50	100	92	6	FXR505Ø19.000H7MV0A-HP145	30570770

Misure in mm.

Per i parametri di lavorazione consigliati, vedere la fine del capitolo.

FXR505 | Versione fissa con scanalatura dritta

Caratteristiche configurabili

**Diametro del foro tolleranza \geq IT6:**

- Diametro a libera scelta a passi da 0,001 mm
- Ordinabile in tolleranza \geq IT6

**Specifiche:**

FXR505Ø[diametro][tolleranza]MVOA-HP145

Variante G:

- Diametro a libera scelta a passi da 0,001 mm
- Ordinabile a partire da una tolleranza $\geq 4 \mu\text{m}$ (variante G vedere pagina 320)

Specifiche variante G:

FXR505GØ[diametro][tolleranza]MVOA-HP145

Dimensioni serie configurabile IT6

d_1	d_2	l_1	l_2	l_3	l_4	l_5	z
2,800 - 3,350	4	65	12	37	28	33	4
3,351 - 3,700	4	65	12	28	37	33	4
3,701 - 6,200	6	75	12	36	39	34	4
6,201 - 8,200	8	100	16	36	64	58	6
8,201 - 9,200	10	100	20	40	60	54	6
9,201 - 10,200	10	120	20	40	80	74	6
10,201 - 12,200	12	120	20	45	75	68	6
12,201 - 14,200	14	130	22	45	85	78	6
14,201 - 15,200	16	130	22	48	82	75	6
15,201 - 16,200	16	150	25	48	102	95	6
16,201 - 18,200	18	150	25	48	102	95	6
18,201 - 20,200	20	150	25	50	100	92	6

Esempio tolleranza IT6:

FXR505Ø16.350H6MVOA-HP145

Diametro del foro $d_1 = 16,350 \text{ H6}$ **Esempio variante G:**

FXR505GØ16.350-4MVOA-HP145

Diametro utensile speciale $d_1 = 16,350 -4 \mu\text{m}$

FixReam

Versione fissa con scanalatura dritta, per foro cieco
FXR505

Versione:

Diametro alesatore:

3,701 - 20,200 mm

Imbocco:

MT0A

Materiale da taglio:

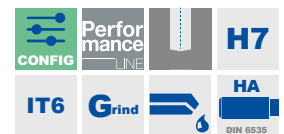
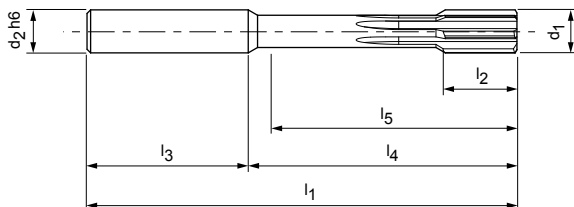
 HP145
 metallo duro rivestito
 in PVD

Serie selezionata per il magazzino in H7

d ₁ H7	Dimensioni						z	Specifiche	Codice
	d ₂ h6	l ₁	l ₂	l ₃	l ₄	l ₅			
4,000	6	75	12	36	39	34	4	FXR505Ø4.000H7MT0A-HP145	30570797
5,000	6	75	12	36	39	34	4	FXR505Ø5.000H7MT0A-HP145	30570799
6,000	6	75	12	36	39	34	4	FXR505Ø6.000H7MT0A-HP145	30570801
8,000	8	100	16	36	64	58	6	FXR505Ø8.000H7MT0A-HP145	30570805
10,000	10	120	20	40	80	74	6	FXR505Ø10.000H7MT0A-HP145	30570809
12,000	12	120	20	45	75	68	6	FXR505Ø12.000H7MT0A-HP145	30570813

Caratteristiche configurabili

Diametro del foro tolleranza ≥ IT6:

- Diametro a libera scelta a passi da 0,001 mm
- Ordinabile in tolleranza ≥ IT6

Specifiche:

FXR505Ø[diametro][tolleranza]MT0A-HP145

Variante G:

- Diametro a libera scelta a passi da 0,001 mm
- Ordinabile a partire da una tolleranza ≥ 4 µm (variante G vedere pagina 320)

Specifiche variante G:

FXR505GØ[diametro][tolleranza]MT0A-HP145

Dimensioni serie configurabile IT6

d ₁	d ₂	l ₁	l ₂	l ₃	l ₄	l ₅	z
3,701 - 6,200	6	75	12	36	39	34	4
6,201 - 8,200	8	100	16	36	64	58	6
8,201 - 9,200	10	100	20	40	60	54	6
9,201 - 10,200	10	120	20	40	80	74	6
10,201 - 12,200	12	120	20	45	75	68	6
12,201 - 14,200	14	130	22	45	85	78	6
14,201 - 15,200	16	130	22	48	82	75	6
15,201 - 16,200	16	150	25	48	102	95	6
16,201 - 18,200	18	150	25	48	102	95	6
18,201 - 20,200	20	150	25	50	100	92	6

Esempio tolleranza IT6:

FXR505Ø16.350H6MT0A-HP145

 Diametro del foro d₁ = 16,350 H6

Esempio variante G:

FXR505GØ16.350-4MT0A-HP145

 Diametro utensile speciale d₁ = 16,350 -4 µm

Misure in mm.

Per i parametri di lavorazione consigliati, vedere la fine del capitolo.

FixReam

Versione fissa con scanalatura dritta, per foro cieco
FXR505

Versione:

Diametro alesatore:

3,701 - 20,200 mm

Imbocco:

MV0A

Materiale da taglio:

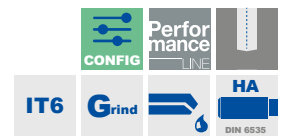
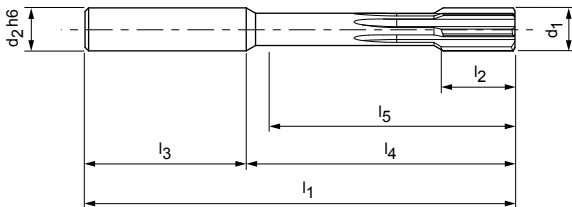
 HP622
 metallo duro rivestito
 in PVD

Caratteristiche configurabili

Diametro del foro tolleranza \geq IT6:

- Diametro a libera scelta a passi da 0,001 mm
- Ordinabile in tolleranza \geq IT6

Specifiche:

FXR505Ø[diametro][tolleranza]MV0A-HP622

Variante G:

- Diametro a libera scelta a passi da 0,001 mm
- Ordinabile a partire da una tolleranza \geq 4 μ m (variante G vedere pagina 320)

Specifiche variante G:

FXR505GØ[diametro][tolleranza]MV0A-HP622

Dimensioni serie configurabile IT6

d_1	d_2	l_1	l_2	l_3	l_4	l_5	z
3,701 - 6,200	6	75	12	36	39	34	4
6,201 - 8,200	8	100	16	36	64	58	6
8,201 - 9,200	10	100	20	40	60	54	6
9,201 - 10,200	10	120	20	40	80	74	6
10,201 - 12,200	12	120	20	45	75	68	6
12,201 - 14,200	14	130	22	45	85	78	6
14,201 - 15,200	16	130	22	48	82	75	6
15,201 - 16,200	16	150	25	48	102	95	6
16,201 - 18,200	18	150	25	48	102	95	6
18,201 - 20,200	20	150	25	50	100	92	6

Esempio tolleranza IT6:

FXR505Ø16.350H6MV0A-HP622

 Diametro del foro $d_1 = 16,350$ H6

Esempio variante G:

FXR505GØ16.350-4MV0A-HP622

 Diametro utensile speciale $d_1 = 16,350 -4 \mu$ m

Misure in mm.

Per i parametri di lavorazione consigliati, vedere la fine del capitolo.

FixReam

Versione fissa con scanalatura dritta, per foro cieco
FXR505

Versione:

Diametro alesatore:

2,800 - 20,200 mm

Imbocco:

MV0A

Materiale da taglio:

HU612

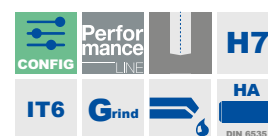
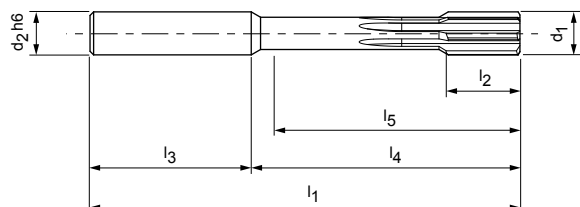
 Metallo duro non
rivestito

Serie selezionata per il magazzino in H7

d ₁ H7	Dimensioni						z	Specifiche	Codice
	d ₂ h6	l ₁	l ₂	l ₃	l ₄	l ₅			
4,000	6	75	12	36	39	34	4	FXR505Ø4.000H7MV0A-HU612	30570694
5,000	6	75	12	36	39	34	4	FXR505Ø5.000H7MV0A-HU612	30570696
6,000	6	75	12	36	39	34	4	FXR505Ø6.000H7MV0A-HU612	30570698
7,000	8	100	16	36	64	58	6	FXR505Ø7.000H7MV0A-HU612	30570700
8,000	8	100	16	36	64	58	6	FXR505Ø8.000H7MV0A-HU612	30570702
9,000	10	100	20	40	60	54	6	FXR505Ø9.000H7MV0A-HU612	30570704
10,000	10	120	20	40	80	74	6	FXR505Ø10.000H7MV0A-HU612	30570706
12,000	12	120	20	45	75	68	6	FXR505Ø12.000H7MV0A-HU612	30570710
13,000	14	130	22	45	85	78	6	FXR505Ø13.000H7MV0A-HU612	30570711
14,000	14	130	22	45	85	78	6	FXR505Ø14.000H7MV0A-HU612	30570712
15,000	16	130	22	48	82	75	6	FXR505Ø15.000H7MV0A-HU612	30570713
16,000	16	150	25	48	102	95	6	FXR505Ø16.000H7MV0A-HU612	30570714
18,000	18	150	25	48	102	95	6	FXR505Ø18.000H7MV0A-HU612	30570716
19,000	20	150	25	50	100	92	6	FXR505Ø19.000H7MV0A-HU612	30570717

Misure in mm.

Per i parametri di lavorazione consigliati, vedere la fine del capitolo.

FXR505 | Versione fissa con scanalatura dritta

Caratteristiche configurabili

**Diametro del foro tolleranza \geq IT6:**

- Diametro a libera scelta a passi da 0,001 mm
- Ordinabile in tolleranza \geq IT6

**Specifiche:**

FXR505Ø[diametro][tolleranza]MV0A-HU612

Variante G:

- Diametro a libera scelta a passi da 0,001 mm
- Ordinabile a partire da una tolleranza $\geq 3 \mu\text{m}$ (variante G vedere pagina 320)

Specifiche variante G:

FXR505GØ[diametro][tolleranza]MV0A-HU612

Dimensioni serie configurabile IT6

d_1	d_2	l_1	l_2	l_3	l_4	l_5	z
2,800 - 3,350	4	65	12	37	28	33	4
3,351 - 3,700	4	65	12	28	37	33	4
3,701 - 6,200	6	75	12	36	39	34	4
6,201 - 8,200	8	100	16	36	64	58	6
8,201 - 9,200	10	100	20	40	60	54	6
9,201 - 10,200	10	120	20	40	80	74	6
10,201 - 12,200	12	120	20	45	75	68	6
12,201 - 14,200	14	130	22	45	85	78	6
14,201 - 15,200	16	130	22	48	82	75	6
15,201 - 16,200	16	150	25	48	102	95	6
16,201 - 18,200	18	150	25	48	102	95	6
18,201 - 20,200	20	150	25	50	100	92	6

Esempio tolleranza IT6:

FXR505Ø16.350H6MV0A-HU612

Diametro del foro $d_1 = 16,350 \text{ H6}$ **Esempio variante G:**

FXR505GØ16.350-3MV0A-HU612

Diametro utensile speciale $d_1 = 16,350 -3 \mu\text{m}$

FixReam

Versione fissa con scanalatura dritta, per foro cieco
FXR505

Versione:

Diametro alesatore:

3,701 - 20,200 mm

Imbocco:

MT0A

Materiale da taglio:

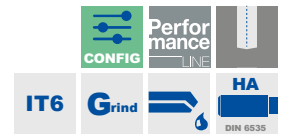
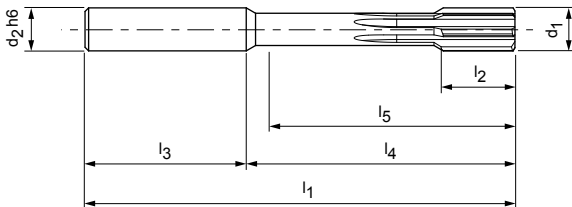
 HP625
 metallo duro rivestito
 in PVD

Caratteristiche configurabili

Diametro del foro tolleranza \geq IT6:

- Diametro a libera scelta a passi da 0,001 mm
- Ordinabile in tolleranza \geq IT6

Specifiche:

FXR505Ø[diametro][tolleranza]MT0A-HP625

Variante G:

- Diametro a libera scelta a passi da 0,001 mm
- Ordinabile a partire da una tolleranza \geq 4 μ m (variante G vedere pagina 320)

Specifiche variante G:

FXR505GØ[diametro][tolleranza]MT0A-HP625

Dimensioni serie configurabile IT6

d_1	d_2	l_1	l_2	l_3	l_4	l_5	z
3,701 - 6,200	6	75	12	36	39	34	4
6,201 - 8,200	8	100	16	36	64	58	6
8,201 - 9,200	10	100	20	40	60	54	6
9,201 - 10,200	10	120	20	40	80	74	6
10,201 - 12,200	12	120	20	45	75	68	6
12,201 - 14,200	14	130	22	45	85	78	6
14,201 - 15,200	16	130	22	48	82	75	6
15,201 - 16,200	16	150	25	48	102	95	6
16,201 - 18,200	18	150	25	48	102	95	6
18,201 - 20,200	20	150	25	50	100	92	6

Esempio tolleranza IT6:

FXR505Ø16.350H6MT0A-HP625

 Diametro del foro $d_1 = 16,350$ H6

Esempio variante G:

FXR505GØ16.350-4MT0A-HP625

 Diametro utensile speciale $d_1 = 16,350 -4 \mu$ m

FixReam

Versione fissa con scanalatura dritta, per foro cieco
FXR505

Versione:

Diametro alesatore:

3,701 - 20,200 mm

Imbocco:

MVOA

Materiale da taglio:

HC614

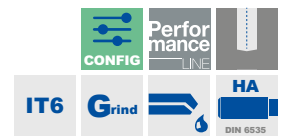
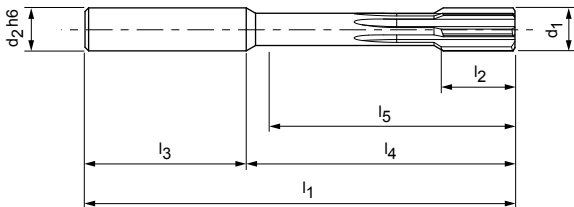
 Metallo duro rivestito
in CVD

Caratteristiche configurabili

Diametro del foro tolleranza \geq IT6:

- Diametro a libera scelta a passi da 0,001 mm
- Ordinabile in tolleranza \geq IT6

Specifiche:

FXR505Ø[diametro][tolleranza]MVOA-HC614

Variante G:

- Diametro a libera scelta a passi da 0,001 mm
- Ordinabile a partire da una tolleranza \geq 4 μ m (variante G vedere pagina 320)

Specifiche variante G:

FXR505GØ[diametro][tolleranza]MVOA-HC614

Dimensioni serie configurabile IT6

d_1	d_2	l_1	l_2	l_3	l_4	l_5	z
3,701 - 6,200	6	75	12	36	39	34	4
6,201 - 8,200	8	100	16	36	64	58	6
8,201 - 9,200	10	100	20	40	60	54	6
9,201 - 10,200	10	120	20	40	80	74	6
10,201 - 12,200	12	120	20	45	75	68	6
12,201 - 14,200	14	130	22	45	85	78	6
14,201 - 15,200	16	130	22	48	82	75	6
15,201 - 16,200	16	150	25	48	102	95	6
16,201 - 18,200	18	150	25	48	102	95	6
18,201 - 20,200	20	150	25	50	100	92	6

Esempio tolleranza IT6:

FXR505Ø16.350H6MVOA-HC614

 Diametro del foro $d_1 = 16,350$ H6

Esempio variante G:

FXR505GØ16.350-4MVOA-HC614

 Diametro utensile speciale $d_1 = 16,350 -4 \mu$ m

Misure in mm.

Per i parametri di lavorazione consigliati, vedere la fine del capitolo.

FixReam

Versione fissa con scanalatura dritta, per foro cieco
FXR505

Versione:

Diametro alesatore:

3,701 - 20,200 mm

Imbocco:

MT0A

Materiale da taglio:

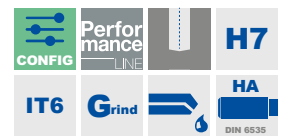
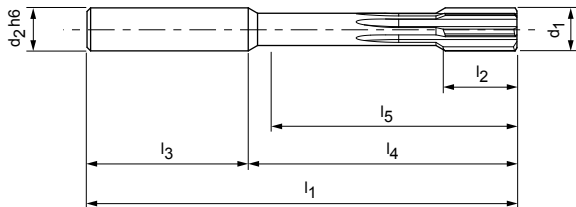
 HP141
 metallo duro rivestito
 in PVD

Caratteristiche configurabili

Diametro del foro tolleranza \geq IT6:

- Diametro a libera scelta a passi da 0,001 mm
- Ordinabile in tolleranza \geq IT6

Specifiche:

FXR505Ø[diametro][tolleranza]MT0A-HP141

Variante G:

- Diametro a libera scelta a passi da 0,001 mm
- Ordinabile a partire da una tolleranza \geq 5 μ m (variante G vedere pagina 320)

Specifiche variante G:

FXR505GØ[diametro][tolleranza]MT0A-HP141

Dimensioni serie configurabile IT6

d_1	d_2	l_1	l_2	l_3	l_4	l_5	z
3,701 - 6,200	6	75	12	36	39	34	4
6,201 - 8,200	8	100	16	36	64	58	6
8,201 - 9,200	10	100	20	40	60	54	6
9,201 - 10,200	10	120	20	40	80	74	6
10,201 - 12,200	12	120	20	45	75	68	6
12,201 - 14,200	14	130	22	45	85	78	6
14,201 - 15,200	16	130	22	48	82	75	6
15,201 - 16,200	16	150	25	48	102	95	6
16,201 - 18,200	18	150	25	48	102	95	6
18,201 - 20,200	20	150	25	50	100	92	6

Esempio tolleranza IT6:

FXR505Ø16.350H6MT0A-HP141

 Diametro del foro $d_1 = 16,350$ H6

Esempio variante G:

FXR505GØ16.350-5MT0A-HP141

 Diametro utensile speciale $d_1 = 16,350 -5 \mu$ m

FixReam

Versione fissa con scanalatura dritta, per foro cieco
FXR503-short

Versione:

Diametro alesatore:

2,800 - 20,100 mm

Imbocco:

MC1F

Materiale da taglio:

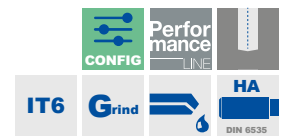
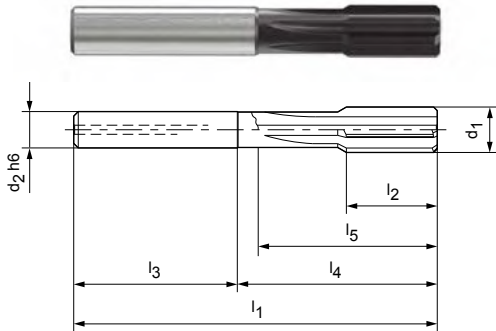
 HP145
 metallo duro rivestito
 in PVD

Caratteristiche configurabili

Diametro del foro tolleranza \geq IT6:

- Diametro a libera scelta a passi da 0,001 mm
- Ordinabile in tolleranza \geq IT6

Specifiche:

FXR503Ø[diametro][tolleranza]MC1F-HP145

Variante G:

- Diametro a libera scelta a passi da 0,001 mm
- Ordinabile a partire da una tolleranza \geq 4 μ m (variante G vedere pagina 320)

Specifiche variante G:

FXR503GØ[diametro][tolleranza]MC1F-HP145

Dimensioni serie configurabile IT6

d_1	d_2	l_1	l_2	l_3	l_4	l_5	z
2,800 - 4,050	4	56	12	28	28	24	4
4,051 - 5,100	6	64	12	36	28	23	4
5,101 - 5,600	6	64	12	36	28	24	4
6,101 - 6,600	8	75	16	36	39	32	6
6,601 - 7,100	8	75	16	36	39	34	6
7,101 - 8,100	8	75	16	36	39	35	6
8,101 - 10,100	8	75	20	36	39	35	6
10,101 - 11,600	10	80	20	40	40	35	6
11,601 - 13,100	12	90	22	45	45	40	6
13,101 - 15,100	14	90	22	45	45	40	6
15,101 - 18,100	16	100	25	48	52	47	8
18,101 - 20,100	18	100	25	48	52	47	8

Esempio tolleranza IT6:

FXR503Ø16.350H6MC1F-HP145

 Diametro del foro $d_1 = 16,350$ H6

Esempio variante G:

FXR503GØ16.350-4MC1F-HP145

 Diametro utensile speciale $d_1 = 16,350$ -4 μ m



Parametri di lavorazione consigliati per FixReam FXR

Avanzamento e velocità di taglio

FXR510 | FXR505

Materiale da taglio: HP145 | Imbocco: MF1M | MT0A

GTM*	Materiale	Resistenza/durezza [N/mm ²] [HRC]	Velocità di taglio v _c (m/min)			
			Adduzione interna del refrigerante	Raffreddamento esterno	MQL	
P	P4 P4.1	Acciai inossidabili, ferritici e martensitici	40	20	30	
	P6 P6.1	Acciaio fuso, ferritico e martensitico	40	20	30	
M	M1 M1.1	Acciai inossidabili, austenitici	< 700	40	20	30
	M1 M1.2	Acciai inossidabili, ferritici/austenitici (Duplex)	< 1000	30	15	20
	M2 M2.1	Acciaio fuso inossidabile, austenitico	< 700	40	20	30
	M3 M3.1	Acciaio fuso inossidabile, ferritico/austenitico (Duplex)	< 1000	30	15	20

FXR510 | FXR505

Materiale da taglio: HP145 | Imbocco: MG1M | MVOA

GTM*	Materiale	Resistenza/durezza [N/mm ²] [HRC]	Velocità di taglio v _c (m/min)			
			Adduzione interna del refrigerante	Raffreddamento esterno	MQL	
P	P1 P1.1	Acciai da costruzione, automatici, da cementazione e da bonifica, non legati	< 700	180	90	150
	P1 P1.2	Acciai da costruzione, automatici, da cementazione e da bonifica, non legati	< 1200	140	70	115
	P2 P2.1	Acciai da niturazione, da cementazione e da bonifica, legati	< 900	180	90	150
	P2 P2.2	Acciai da niturazione, da cementazione e da bonifica, legati	< 1400	140	70	115
	P3 P3.1	Acciai per utensili, per cuscinetti volventi, armonici e per lavorazioni veloci**	< 800	180	90	150
	P3 P3.2	Acciai per utensili, per cuscinetti volventi, armonici e per lavorazioni veloci**	< 1000	140	70	110
	P3 P3.3	Acciai per utensili, per cuscinetti volventi, armonici e per lavorazioni veloci**	< 1500	120	60	90
	P6 P5.1	Acciaio fuso		140	75	100
K	K1 K1.1	Ghisa con grafite lamellare (ghisa grigia), GJL	< 300	120	100	100
	K1 K2.1	Ghisa con grafite sferoidale, GJS	< 500	150	105	130
	K2 K2.2	Ghisa con grafite sferoidale, GJS	≤ 800	120	85	98
	K2 K2.3	Ghisa con grafite sferoidale, GJS	> 800	90	55	70
	K3 K3.1	Ghisa con grafite vermicolare, GJV; acciaio fuso malleabile, GJM	< 500	90	55	70
	K3 K3.2	Ghisa con grafite vermicolare, GJV; acciaio fuso malleabile, GJM	> 500	90	55	70

* Gruppi di materiale MAPAL

** Qualora la somma dei componenti di lega Cr, Mo, Ni, V, W equivalesse a > 8%, selezionare il gruppo di materiale MAPAL immediatamente superiore.

	Avanzamento f_z (mm/z) per il diametro dell'utensile						
	z 4	z 4	z 6	z 6	z 6	z 6	z 8
	< 5,000	> 5,000 - 6,200	> 6,200 - 8,000	> 8,000 - 12,000	> 12,000 - 16,000	> 16,000 - 16,200	> 16,200 - 20,200
	0,020	0,040	0,060	0,080	0,100	0,120	0,120
	0,020	0,040	0,060	0,080	0,100	0,120	0,120
	0,020	0,040	0,060	0,080	0,100	0,120	0,120
	0,020	0,040	0,060	0,080	0,100	0,120	0,120
	0,020	0,040	0,060	0,080	0,100	0,120	0,120
	0,020	0,040	0,060	0,080	0,100	0,120	0,120

	Avanzamento f_z (mm/z) per il diametro dell'utensile						
	z 4	z 4	z 6	z 6	z 6	z 6	z 8
	< 5,000	> 5,000 - 6,200	> 6,200 - 8,000	> 8,000 - 12,000	> 12,000 - 16,000	> 16,000 - 16,200	> 16,200 - 20,200
	0,050	0,080	0,080	0,140	0,180	0,180	0,190
	0,050	0,080	0,080	0,140	0,180	0,180	0,190
	0,050	0,080	0,080	0,140	0,180	0,180	0,190
	0,050	0,080	0,080	0,140	0,180	0,180	0,190
	0,050	0,080	0,080	0,140	0,180	0,180	0,190
	0,050	0,080	0,080	0,140	0,180	0,180	0,190
	0,050	0,080	0,080	0,140	0,180	0,180	0,190
	0,050	0,080	0,080	0,140	0,180	0,180	0,190
	0,080	0,100	0,100	0,170	0,220	0,220	0,230
	0,080	0,100	0,100	0,170	0,220	0,220	0,230
	0,080	0,100	0,100	0,170	0,220	0,220	0,230
	0,080	0,100	0,100	0,170	0,220	0,220	0,230
	0,080	0,100	0,100	0,170	0,220	0,220	0,230
	0,080	0,100	0,100	0,170	0,220	0,220	0,230

I parametri di lavorazione indicati sono valori orientativi.

I dati ottimali per la specifica applicazione devono essere rilevati eseguendo diversi tentativi o durante l'effettiva lavorazione.

Parametri di lavorazione consigliati per FixReam FXR

Avanzamento e velocità di taglio

FXR503-short

Materiale da taglio: HP145 | Imbocco: MC1F

GTM*	Materiale	Resistenza/durezza [N/mm ²] [HRC]	Velocità di taglio v _c (m/min)			
			Adduzione interna del refrigerante	Raffreddamento esterno	MQL	
P	P1.1	Acciai da costruzione, automatici, da cementazione e da bonifica, non legati	< 700	180	90	150
	P1.2	Acciai da costruzione, automatici, da cementazione e da bonifica, non legati	< 1200	140	70	115
	P2.1	Acciai da nitrurazione, da cementazione e da bonifica, legati	< 900	180	90	150
	P2.2	Acciai da nitrurazione, da cementazione e da bonifica, legati	< 1400	140	70	115
	P3.1	Acciai per utensili, per cuscinetti volventi, armonici e per lavorazioni veloci**	< 800	180	90	150
	P3.2	Acciai per utensili, per cuscinetti volventi, armonici e per lavorazioni veloci**	< 1000	140	70	110
	P3.3	Acciai per utensili, per cuscinetti volventi, armonici e per lavorazioni veloci**	< 1500	120	60	90
	P6	P5.1	Acciaio fuso		140	75
K	K1.1	Ghisa con grafite lamellare (ghisa grigia), GJL	< 300	120	100	100
	K2.1	Ghisa con grafite sferoidale, GJS	< 500	150	105	130
	K2.2	Ghisa con grafite sferoidale, GJS	≤ 800	120	85	98
	K2.3	Ghisa con grafite sferoidale, GJS	> 800	90	55	70
	K3.1	Ghisa con grafite vermicolare, GJV; acciaio fuso malleabile, GJM	< 500	90	55	70
	K3.2	Ghisa con grafite vermicolare, GJV; acciaio fuso malleabile, GJM	> 500	90	55	70

FXR505 | FXR500

Materiale da taglio: HP622 | Imbocco: MVOA | MGOA

GTM*	Materiale	Resistenza/durezza [N/mm ²] [HRC]	Velocità di taglio v _c (m/min)			
			Adduzione interna del refrigerante	Raffreddamento esterno	MQL	
N	N1	N1.1	Alluminio, non legato e legato < 3% Si	250	125	190
		N1.2	Alluminio, legato ≤ 7% Si	250	125	190
		N1.3	Alluminio, legato > 7-12% Si	250	125	190
		N1.4	Alluminio, legato > 12% Si	250	125	190

FXR505 | FXR510

Materiale da taglio: HU612 | Imbocco: MVOA | MG1M

GTM*	Materiale	Resistenza/durezza [N/mm ²] [HRC]	Velocità di taglio v _c (m/min)			
			Adduzione interna del refrigerante	Raffreddamento esterno	MQL	
N2	N2.1	Rame, non legato e bassolegato	< 300	50	25	
	N2.2	Rame, legato	> 300	50	25	
	N2.3	Ottone, bronzo, ghisa rossa	< 1200	50	25	40

* Gruppi di materiale MAPAL

** Qualora la somma dei componenti di lega Cr, Mo, Ni, V, W equivalesse a > 8%, selezionare il gruppo di materiale MAPAL immediatamente superiore.

	Avanzamento f_z (mm/z) per il diametro dell'utensile						
	z 4	z 4	z 6	z 6	z 6	z 8	z 8
	< 5,000	> 5,000 - 6,100	> 6,100 - 8,000	> 8,000 - 12,000	> 12,000 - 15,100	> 15,100 - 16,000	> 16,000 - 20,100
	0,050	0,080	0,080	0,140	0,180	0,180	0,190
	0,050	0,080	0,080	0,140	0,180	0,180	0,190
	0,050	0,080	0,080	0,140	0,180	0,180	0,190
	0,050	0,080	0,080	0,140	0,180	0,180	0,190
	0,050	0,080	0,080	0,140	0,180	0,180	0,190
	0,050	0,080	0,080	0,140	0,180	0,180	0,190
	0,050	0,080	0,080	0,140	0,180	0,180	0,190
	0,050	0,080	0,080	0,140	0,180	0,180	0,190
	0,08	0,10	0,10	0,17	0,22	0,22	0,23
	0,08	0,10	0,10	0,17	0,22	0,22	0,23
	0,08	0,10	0,10	0,17	0,22	0,22	0,23
	0,08	0,10	0,10	0,17	0,22	0,22	0,23
	0,08	0,10	0,10	0,17	0,22	0,22	0,23
	0,08	0,10	0,10	0,17	0,22	0,22	0,23

	Avanzamento f_z (mm/z) per il diametro dell'utensile						
	z 4	z 4	z 6	z 6	z 6	z 6	z 6
	< 5,000	> 5,000 - 6,200	> 6,200 - 8,000	> 8,000 - 12,000	> 12,000 - 16,000	> 16,000 - 16,200	> 16,200 - 20,200
	0,120	0,150	0,150	0,210	0,250	0,250	0,300
	0,120	0,150	0,150	0,210	0,250	0,250	0,300
	0,120	0,150	0,150	0,210	0,250	0,250	0,300
	0,120	0,150	0,150	0,210	0,250	0,250	0,300

	Avanzamento f_z (mm/z) per il diametro dell'utensile						
	z 4	z 4	z 6	z 6	z 6	z 6	z 8
	< 5,000	> 5,000 - 6,200	> 6,200 - 8,000	> 8,000 - 12,000	> 12,000 - 16,000	> 16,000 - 16,200	> 16,200 - 20,200
	0,040	0,050	0,050	0,060	0,100	0,100	0,100
	0,040	0,050	0,050	0,060	0,100	0,100	0,100
	0,040	0,050	0,050	0,060	0,100	0,100	0,100

I parametri di lavorazione indicati sono valori orientativi.

I dati ottimali per la specifica applicazione devono essere rilevati eseguendo diversi tentativi o durante l'effettiva lavorazione.

Parametri di lavorazione consigliati per FixReam FXR

Avanzamento e velocità di taglio

FXR510 | FXR505

Materiale da taglio: HP625 | Imbocco: MF1M | MTOA

GTM*	Materiale	Resistenza/durezza [N/mm ²] [HRC]	Velocità di taglio v _c (m/min)			
			Adduzione interna del refrigerante	Raffreddamento esterno	MQL	
S	S1 S1.1	Titanio, leghe di titanio	< 400	25	10	15
	S2 S2.1	Titanio, leghe di titanio	< 1200	25	10	15
	S2 S2.2	Titanio, leghe di titanio	> 1200	25	10	15
	S3 S3.1	Nichel, non legato e legato	< 900	25	10	15
	S3 S3.2	Nichel, non legato e legato	> 900	25	10	15
	S4 S4.1	Superlega resistente ad alte temperature a base di Ni, Co e Fe		25	10	15
	S5 S5.1	Leghe di tungsteno e molibdeno		25	10	15

FXR510 | FXR505

Materiale da taglio: HC614 | Imbocco: MF1M | MVOA

GTM*	Materiale	Resistenza/durezza [N/mm ²] [HRC]	Velocità di taglio v _c (m/min)			
			Adduzione interna del refrigerante	Raffreddamento esterno	MQL	
C	C1 C1.1	Matrice plastica, rinforzata con fibre di aramide (AFK)		50	25	30
	C1 C1.2	Matrice plastica (duroplastica), CFK/GFK		50	25	30
	C1 C1.3	Matrice plastica (termoplastica), CFK/GFK		50	25	30

FXR500 | FXR505

Materiale da taglio: HP141 | Imbocco: MFOA | MTOA

GTM*	Materiale	Resistenza/durezza [N/mm ²] [HRC]	Velocità di taglio v _c (m/min)			
			Adduzione interna del refrigerante	Raffreddamento esterno	MQL	
H	H1 H1.1	Acciaio temprato/acciaio fuso	< 44	50	20	30
	H1 H1.2	Acciaio temprato/acciaio fuso	< 55	10	5	5

	Avanzamento f_z (mm/z) per il diametro dell'utensile						
	z 4	z 4	z 6	z 6	z 6	z 6	z 8
	< 5,000	> 5,000 - 6,200	> 6,200 - 8,000	> 8,000 - 12,000	> 12,000 - 16,000	> 16,000 - 16,200	> 16,200 - 20,200
	0,020	0,040	0,060	0,080	0,100	0,100	0,100
	0,020	0,040	0,060	0,080	0,100	0,100	0,100
	0,020	0,040	0,060	0,080	0,100	0,100	0,100
	0,020	0,040	0,060	0,080	0,100	0,100	0,100
	0,020	0,040	0,060	0,080	0,100	0,100	0,100
	0,020	0,040	0,060	0,080	0,100	0,100	0,100
	0,020	0,040	0,060	0,080	0,100	0,100	0,100

	Avanzamento f_z (mm/z) per il diametro dell'utensile						
	z 4	z 4	z 6	z 6	z 6	z 6	z 8
	< 5,000	> 5,000 - 6,200	> 6,200 - 8,000	> 8,000 - 12,000	> 12,000 - 16,000	> 16,000 - 16,200	> 16,200 - 20,200
	0,060	0,100	0,100	0,100	0,100	0,100	0,100
	0,060	0,100	0,100	0,100	0,100	0,100	0,100
	0,060	0,100	0,100	0,100	0,100	0,100	0,100

	Avanzamento f_z (mm/z) per il diametro dell'utensile						
	z 4	z 4	z 6	z 6	z 6	z 6	z 6
	< 5,000	> 5,000 - 6,200	> 6,200 - 8,000	> 8,000 - 12,000	> 12,000 - 16,000	> 16,000 - 16,200	> 16,200 - 20,200
	0,015	0,025	0,020	0,040	0,050	0,050	0,050
	0,015	0,025	0,020	0,040	0,050	0,050	0,050

I parametri di lavorazione indicati sono valori orientativi.

I dati ottimali per la specifica applicazione devono essere rilevati eseguendo diversi tentativi o durante l'effettiva lavorazione.

PANORAMICA PRODOTTI





















Serie MonoReam 700

Gli alesatori a più taglienti della serie MonoReam 700 offrono un nuovo sistema di alesatura standardizzato, semplice e performante. Gli alesatori della serie MonoReam sono disponibili in versione estensibile. A seconda del campo di applicazione e del materiale, possono essere ordinati in versione con scanalatura obliqua sinistra oppure con scanalatura dritta per fori passanti e ciechi, nonché con diversi imbocchi e svariati materiali da taglio.

MonoReam Plus

La serie MonoReam Plus è realizzata specificamente per la lavorazione di ghisa e acciaio. Gli alesatori di questa serie sono muniti di un innovativo sistema di adduzione del refrigerante brevettato. Un'apposita boccola assicura l'apporto ottimale di refrigerante ai taglienti HPC.

L'assortimento per fori passanti e ciechi è perfetto per lavorazioni nel range di diametro da 3,850 a 8,200 mm.

MonoReam			
			
<p>MonoReam 700 Versione con scanalatura dritta per la lavorazione di fori passanti in metalli non ferrosi con taglienti in metallo duro non rivestiti (taglienti in PCD su richiesta).</p> <p>Range di \varnothing: 7,700 - 40,200 mm*</p> <p>   </p> <p></p>	<p>MonoReam 710 Versione con scanalatura obliqua sinistra per la lavorazione di fori passanti con taglienti in metallo duro rivestiti o non rivestiti.</p> <p>Range di \varnothing: 7,700 - 40,200 mm*</p> <p>   </p> <p> </p>	<p>MonoReam 705 Versione con scanalatura dritta per la lavorazione di fori ciechi con taglienti in metallo duro rivestiti o non rivestiti. (taglio PCD su richiesta).</p> <p>Range di \varnothing: 7,700 - 40,200 mm*</p> <p>   </p> <p>  </p>	
Pagina 358	Pagina 356	Pagina 359	

* Il range di diametro può variare a seconda della serie.



Spiegazione del sistema serie 700

Gli alesatori MonoReam della serie 700 vengono impiegati come utensile fisso, ma questa serie è stata ottimizzata per la riaffilatura. Tramite un'apposita vite di espansione è possibile ampliare il diametro dell'alesatore. Il sistema di espansione è adatto esclusivamente alla compensazione prima della riaffilatura, non è pensato per il presettaggio o la registrazione del diametro. L'ampliamento del diametro consente di riaffilare tutte le superfici funzionali, sia nell'imbocco che nel diametro dell'utensile.

MonoReam Plus



MonoReam Plus | MRP510 Testa in cermet integrale

Alesatore ad alte prestazioni con testa in cermet integrale, con scanalatura obliqua sinistra,

Range di \varnothing : 3,850 - 8,200 mm



MonoReam Plus | MRP505 Testa in cermet integrale

Alesatore ad alte prestazioni con testa in cermet integrale, con scanalatura dritta,

Range di \varnothing : 3,850 - 8,200 mm



Riepilogo dell'assortimento MonoReam | MonoReam Plus (1/2)

Classe di prodotto	Tipo di foro	Idoneità del materiale											
		P					K					N	
		1-2	3.1	3.2	3.3	4-6	1	2.1	2.2	2.3	K3	1-2	4
Performance		■	■	■			■	■	■	■			
		■	■	■	■	■	■	■	■	■	■		
												■	■
		■	■	■			■	■	■	■			
		■	■	■	■	■	■	■	■	■	■		
												■	■
		■	■	■			■	■					
		■	■	■			■	■					

Esempio di ordine:

Serie MonoReam Plus

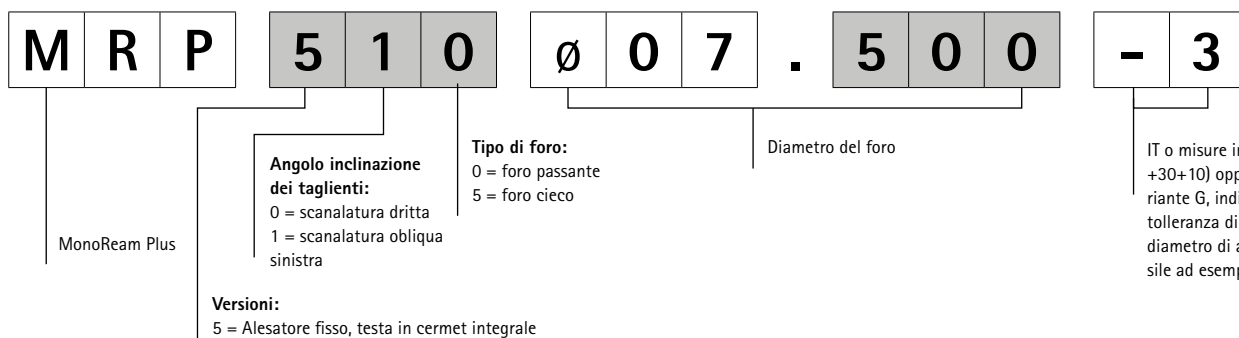





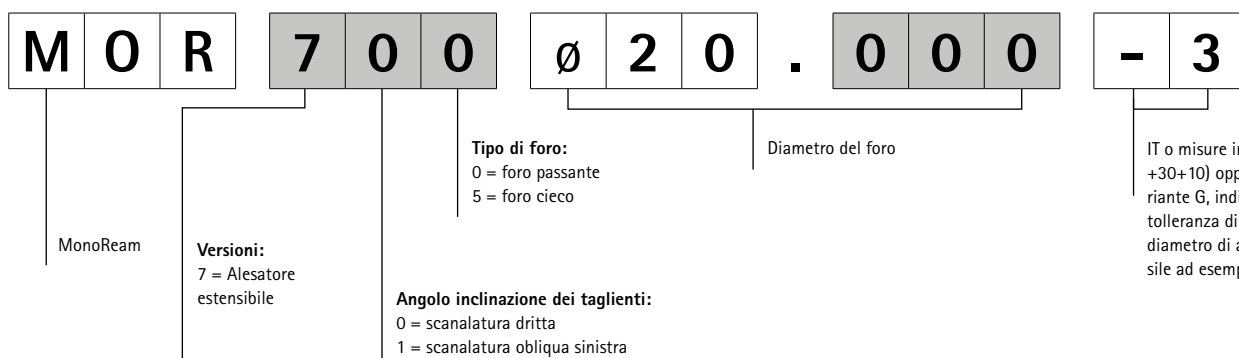

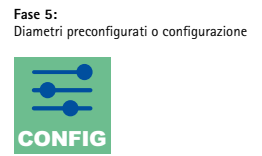





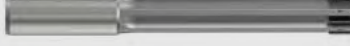

Esempio di ordine:

Serie MonoReam



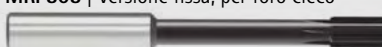

d ₁	Versione				Diametri preconfigurati		Configurazione
	Materiale da taglio	Imbocco	 	Serie	Pagina		
7,700 - 40,200	CU130	MY1G		MOR710	356	MOR710 Versione estensibile, per foro passante 	
7,700 - 40,200	HP421	MY1G		MOR710	357		
7,700 - 40,200	HU612	MY1G		MOR700	358	MOR700 	
7,700 - 40,200	CU130	MU2A		MOR705	359	MOR705 Versione estensibile, per foro cieco 	
7,700 - 40,200	HP421	MU2A		MOR705	360		
7,700 - 40,200	HU612	MU2A		MOR705	361		
3,850 - 8,200	CU178	MG1M		MRP510	362	MRP510 Versione fissa, per foro passante 	
3,850 - 8,200	CU178	MV3C		MRP505	363	MRP505 Versione fissa, per foro cieco 	

Imbocco [Lead]

Materiale da taglio [Cut]

M G 1 M - **C U 1 7 8**

Forma di imbocco e
angolo di spoglia:
MG1M
MV3C

Per la spiegazione delle geometrie di imbocco vedere pagina 752.

Materiale da taglio:
CU178

Imbocco [Lead]

Materiale da taglio [Cut]

M Y 1 G - **C P 1 3 6**

Forma di imbocco e
angolo di spoglia:
MY1G
MU2A

Per la spiegazione delle geometrie di imbocco vedere pagina 752.

Materiale da taglio:
HP421
HU612
CU130
PCD su richiesta

Riepilogo dell'assortimento MonoReam | MonoReam Plus (2/2)

MOR710

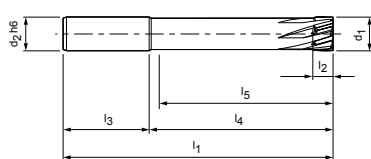

MOR700

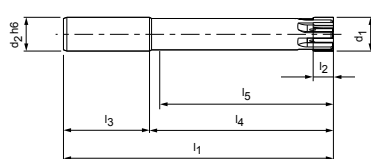

MOR705

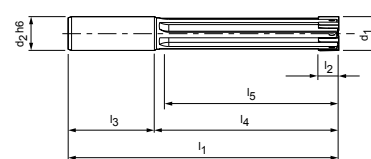

Misure utensili

MOR710 | MOR700

d_1	d_2	l_1	l_2	l_3	l_4	l_5	z
7,700 - 9,700	12	120	8	45	75	70	4
9,701 - 11,700	12	120	8	45	75	70	6
11,701 - 17,200	16	140	8	48	92	87	6
17,201 - 22,200	20	160	12	50	110	105	6
22,201 - 27,200	20	180	12	50	130	125	6
27,201 - 29,200	25	200	12	56	144	139	6
29,201 - 40,200	25	200	12	56	144	139	8

MOR705

d_1	d_2	l_1	l_2	l_3	l_4	l_5	z
7,700 - 9,700	12	120	8	45	75	64	4
9,701 - 11,700	12	120	8	45	75	65	6
11,701 - 17,200	16	140	8	48	92	80	6
17,201 - 18,200	20	160	12	50	110	98	6
18,201 - 19,200	20	160	12	50	110	99	6
19,201 - 22,200	20	160	12	50	110	100	6
22,201 - 27,200	20	180	12	50	130	120	6
27,201 - 29,200	25	200	12	56	144	130	6
29,201 - 40,200	25	200	12	56	144	130	8



MRP510

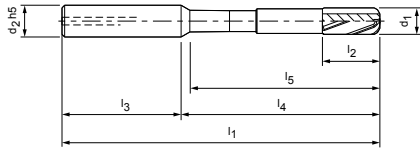

MRP505

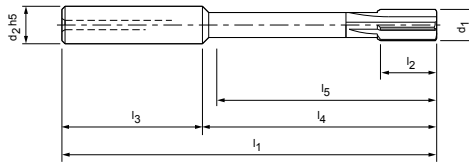
**Misure utensili**

MRP510

d ₁	d ₂	l ₁	l ₂	l ₃	l ₄	l ₅	z
3,850 - 4,900	10	80	14	40	40	33	4
4,901 - 6,200	12	85	14	45	40	33	4
6,201 - 6,700	12	105	14	45	60	52	6
6,701 - 8,200	12	110	18	45	65	57	6

MRP505

d ₁	d ₂	l ₁	l ₂	l ₃	l ₄	l ₅	z
3,850 - 4,900	10	80	12	40	40	33	4
4,901 - 6,200	12	85	12	45	40	33	4
6,201 - 6,700	12	105	12	45	60	53	6
6,701 - 8,200	12	110	16	45	65	58	6

Tolleranze per la variante G/variante fissa MOR7XX | MRP5XX:

Materiale da taglio	Range di diametro
	Ø 7,700 - 40,200
Non rivestito	-0,003
CU130	
HU612	
CU178	
Rivestito (spessore strato 1 - 2 µm)	-0,004
HP421	
CP136	

Spiegazione variante G MOR | MRP

Tolleranze ammesse sul pezzo per la selezione del diametro utensile

Versione variante G:

La variante G indica il diametro dell'utensile dell'alesatore con le nostre tolleranze di produzione. Le tolleranze di produzione dipendono dal materiale da taglio. Vedi tolleranze minime ammesse per la variante G.

MonoReam

Versione estensibile, per foro passante
MOR710

Versione:

Diametro alesatore:

7,700 - 40,200 mm

Imbocco:

MY1G

Materiale da taglio:

CU130

Cermet non rivestito

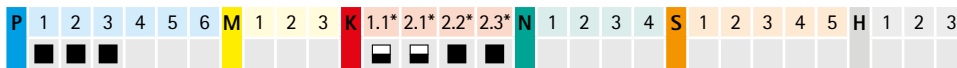
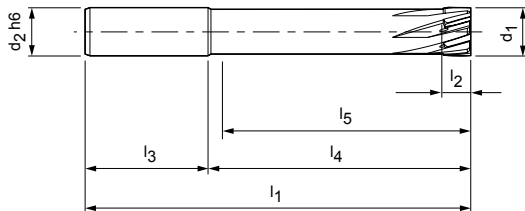
Caratteristiche configurabili

Diametro del foro tolleranza \geq IT6:

- Diametro a libera scelta a passi da 0,001 mm
- Ordinabile in tolleranza \geq IT6

Specifiche:

MOR710Ø[diametro][tolleranza]MY1G-CU130

Variante G:

- Diametro a libera scelta a passi da 0,001 mm
- Ordinabile a partire da una tolleranza \geq 3 μ m (variante G vedere pagina 355)

Specifiche variante G:

MOR710GØ[diametro][tolleranza]MY1G-CU130

Dimensioni serie configurabile IT6

d_1	d_2	l_1	l_2	l_3	l_4	l_5	z
7,700 - 9,700	12	120	8	45	75	70	4
9,701 - 11,700	12	120	8	45	75	70	6
11,701 - 17,200	16	140	8	48	92	87	6
17,201 - 22,200	20	160	12	50	110	105	6
22,201 - 27,200	20	180	12	50	130	125	6
27,201 - 29,200	25	200	12	56	144	139	6
29,201 - 40,200	25	200	12	56	144	139	8

Esempio tolleranza IT6:

MOR710Ø16.350H6MY1G-CU130

 Diametro del foro $d_1 = 16,350$ H6

Esempio variante G:

MOR710GØ16.350-3MY1G-CU130

 Diametro utensile speciale $d_1 = 16,350 -3 \mu$ m

Misure in mm.

 * per superfici $R_a < 2 \mu$ m

Per i parametri di lavorazione consigliati, vedere la fine del capitolo.

MonoReam

Versione estensibile, per foro passante
MOR710

Versione:

Diametro alesatore:

7,700 - 40,200 mm

Imbocco:

MY1G

Materiale da taglio:

metallo duro rivestito

in PVD

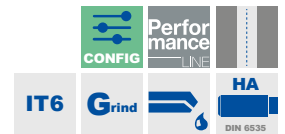
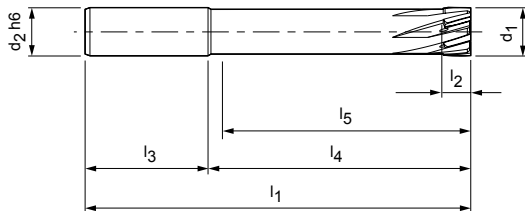
Caratteristiche configurabili

Diametro del foro tolleranza \geq IT6:

- Diametro a libera scelta a passi da 0,001 mm
- Ordinabile in tolleranza \geq IT6

Specifiche:

MOR710Ø[diametro][tolleranza]MY1G-HP421

Variante G:

- Diametro a libera scelta a passi da 0,001 mm
- Ordinabile a partire da una tolleranza \geq 4 μ m (variante G vedere pagina 355)

Specifiche variante G:

MOR710GØ[diametro][tolleranza]MY1G-HP421

Dimensioni serie configurabile IT6

d_1	d_2	l_1	l_2	l_3	l_4	l_5	z
7,700 - 9,700	12	120	8	45	75	70	4
9,701 - 11,700	12	120	8	45	75	70	6
11,701 - 17,200	16	140	8	48	92	87	6
17,201 - 22,200	20	160	12	50	110	105	6
22,201 - 27,200	20	180	12	50	130	125	6
27,201 - 29,200	25	200	12	56	144	139	6
29,201 - 40,200	25	200	12	56	144	139	8

Esempio tolleranza IT6:

MOR710Ø16.350H6MY1G-HP421

 Diametro del foro $d_1 = 16,350$ H6

Esempio variante G:

MOR710GØ16.350-4MY1G-HP421

 Diametro utensile speciale $d_1 = 16,350 -4 \mu$ m

Misure in mm.

Per i parametri di lavorazione consigliati, vedere la fine del capitolo.

MonoReam

Versione estensibile, per foro passante
MOR700

Versione:

Diametro alesatore:

7,700 - 40,200 mm

Imbocco:

MY1G

Materiale da taglio:

HU612

Metallo duro non rivestito

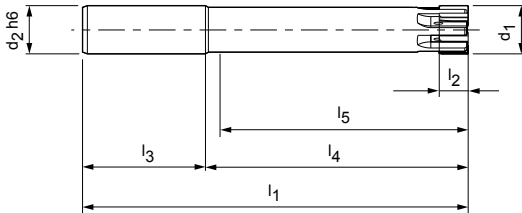

Caratteristiche configurabili



Diametro del foro tolleranza ≥ IT6:

- Diametro a libera scelta a passi da 0,001 mm
- Ordinabile in tolleranza ≥ IT6

Specifiche:

MOR700Ø[diametro][tolleranza]MY1G-HU612

Variante G:

- Diametro a libera scelta a passi da 0,001 mm
- Ordinabile a partire da una tolleranza ≥ 3 µm (variante G vedere pagina 355)

Specifiche variante G:

MOR700GØ[diametro][tolleranza]MY1G-HU612

Dimensioni serie configurabile IT6

d ₁	d ₂	l ₁	l ₂	l ₃	l ₄	l ₅	z
7,700 - 9,700	12	120	8	45	75	70	4
9,701 - 11,700	12	120	8	45	75	70	6
11,701 - 17,200	16	140	8	48	92	87	6
17,201 - 22,200	20	160	12	50	110	105	6
22,201 - 27,200	20	180	12	50	130	125	6
27,201 - 29,200	25	200	12	56	144	139	6
29,201 - 40,200	25	200	12	56	144	139	8

Esempio tolleranza IT6:

MOR700Ø16.350H6MY1G-HU612

Diametro del foro d₁ = 16,350 H6

Esempio variante G:

MOR700GØ16.350-3MY1G-HU612

Diametro utensile speciale d₁ = 16,350 -3 µm

Misure in mm.

Per i parametri di lavorazione consigliati, vedere la fine del capitolo.

MonoReam

Versione estendibile con scanalatura dritta, per foro cieco
MOR705

Versione:

Diametro alesatore:

7,700 - 40,200 mm

Imbocco:

MU2A

Materiale da taglio:

CU130

Cermet non rivestito

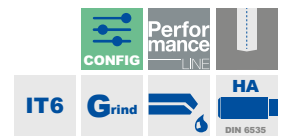
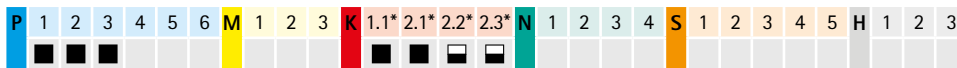
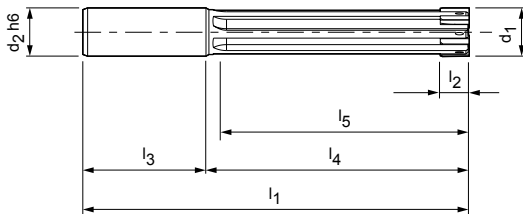

Caratteristiche configurabili

Diametro del foro tolleranza \geq IT6:

- Diametro a libera scelta a passi da 0,001 mm
- Ordinabile in tolleranza \geq IT6

Specifiche:

MOR705Ø[diametro][tolleranza]MU2A-CU130

Variante G:

- Diametro a libera scelta a passi da 0,001 mm
- Ordinabile a partire da una tolleranza \geq 3 μ m (variante G vedere pagina 355)

Specifiche variante G:

MOR705GØ[diametro][tolleranza]MU2A-CU130

Dimensioni serie configurabile IT6

d_1	d_2	l_1	l_2	l_3	l_4	l_5	z
7,700 - 9,700	12	120	8	45	75	64	4
9,701 - 11,700	12	120	8	45	75	65	6
11,701 - 17,200	16	140	8	48	92	80	6
17,201 - 18,200	20	160	12	50	110	98	6
18,201 - 19,200	20	160	12	50	110	99	6
19,201 - 22,200	20	160	12	50	110	100	6
22,201 - 27,200	20	180	12	50	130	120	6
27,201 - 29,200	25	200	12	56	144	130	6
29,201 - 40,200	25	200	12	56	144	130	8

Esempio tolleranza IT6:

MOR705Ø16.350H6MU2A-CU130

 Diametro del foro $d_1 = 16,350$ H6

Esempio variante G:

MOR705GØ16.350-3MU2A-CU130

 Diametro utensile speciale $d_1 = 16,350$ -3 μ m

Misure in mm.

 * per superfici $R_a < 2$ μ m

Per i parametri di lavorazione consigliati, vedere la fine del capitolo.

MonoReam

Versione estendibile con scanalatura dritta, per foro cieco
MOR705

Versione:

Diametro alesatore:

7,700 - 40,200 mm

Imbocco:

MU2A

Materiale da taglio:

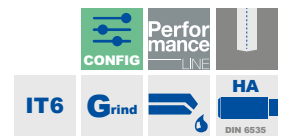
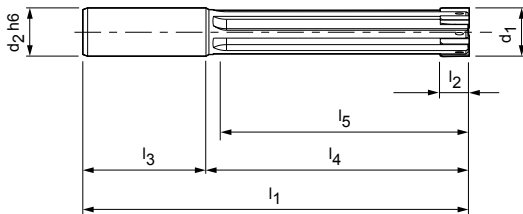
 HP421
metallo duro rivestito
in PVD

Caratteristiche configurabili

Diametro del foro tolleranza \geq IT6:

- Diametro a libera scelta a passi da 0,001 mm
- Ordinabile in tolleranza \geq IT6

Specifiche:

MOR705Ø[diametro][tolleranza]MU2A-HP421

Variante G:

- Diametro a libera scelta a passi da 0,001 mm
- Ordinabile a partire da una tolleranza \geq 4 μ m (variante G vedere pagina 355)

Specifiche variante G:

MOR705GØ[diametro][tolleranza]MU2A-HP421

Dimensioni serie configurabile IT6

d_1	d_2	l_1	l_2	l_3	l_4	l_5	z
7,700 - 9,700	12	120	8	45	75	64	4
9,701 - 11,700	12	120	8	45	75	65	6
11,701 - 17,200	16	140	8	48	92	80	6
17,201 - 18,200	20	160	12	50	110	98	6
18,201 - 19,200	20	160	12	50	110	99	6
19,201 - 22,200	20	160	12	50	110	100	6
22,201 - 27,200	20	180	12	50	130	120	6
27,201 - 29,200	25	200	12	56	144	130	6
29,201 - 40,200	25	200	12	56	144	130	8

Esempio tolleranza IT6:

MOR705Ø16.350H6MU2A-HP421

 Diametro del foro $d_1 = 16,350$ H6

Esempio variante G:

MOR705GØ16.350-4MU2A-HP421

 Diametro utensile speciale $d_1 = 16,350 -4 \mu$ m

MonoReam

Versione estendibile con scanalatura dritta, per foro cieco
MOR705

Versione:

Diametro alesatore:

7,700 - 40,200 mm

Imbocco:

MU2A

Materiale da taglio:

HU612

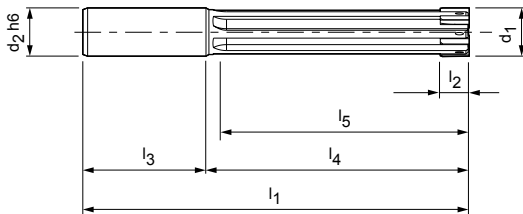
 Metallo duro non
rivestito

Caratteristiche configurabili

Diametro del foro tolleranza \geq IT6:

- Diametro a libera scelta a passi da 0,001 mm
- Ordinabile in tolleranza \geq IT6

Specifiche:

MOR705Ø[diametro][tolleranza]MU2A-HU612

Variante G:

- Diametro a libera scelta a passi da 0,001 mm
- Ordinabile a partire da una tolleranza \geq 3 μ m (variante G vedere pagina 355)

Specifiche variante G:

MOR705GØ[diametro][tolleranza]MU2A-HU612

Dimensioni serie configurabile IT6

d_1	d_2	l_1	l_2	l_3	l_4	l_5	z
7,700 - 9,700	12	120	8	45	75	64	4
9,701 - 11,700	12	120	8	45	75	65	6
11,701 - 17,200	16	140	8	48	92	80	6
17,201 - 18,200	20	160	12	50	110	98	6
18,201 - 19,200	20	160	12	50	110	99	6
19,201 - 22,200	20	160	12	50	110	100	6
22,201 - 27,200	20	180	12	50	130	120	6
27,201 - 29,200	25	200	12	56	144	130	6
29,201 - 40,200	25	200	12	56	144	130	8

Esempio tolleranza IT6:

MOR705Ø16.350H6MU2A-HU612

 Diametro del foro $d_1 = 16,350$ H6

Esempio variante G:

MOR705GØ16.350-3MU2A-HU612

 Diametro utensile speciale $d_1 = 16,350$ -3 μ m

Misure in mm.

Per i parametri di lavorazione consigliati, vedere la fine del capitolo.

MonoReam Plus

Versione fissa, per foro passante
MRP510

Versione:

Diametro alesatore:

3,850 - 8,200 mm

Imbocco:

MG1M

Materiale da taglio:

CU178

Cermet non rivestito

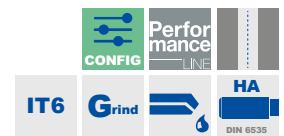
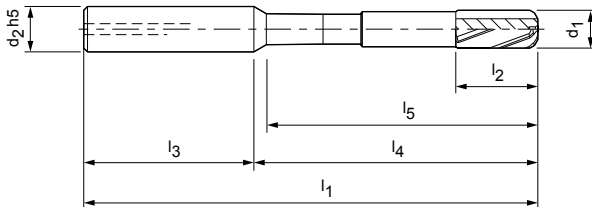

Caratteristiche configurabili

Diametro del foro tolleranza \geq IT6:

- Diametro a libera scelta a passi da 0,001 mm
- Ordinabile in tolleranza \geq IT6

Specifiche:

MRP510Ø[diametro][tolleranza]MG1M-CU178

Variante G:

- Diametro a libera scelta a passi da 0,001 mm
- Ordinabile a partire da una tolleranza \geq 3 μ m (variante G vedere pagina 355)

Specifiche variante G:

MRP510GØ[diametro][tolleranza]MG1M-CU178

Dimensioni serie configurabile IT6

d_1	d_2	l_1	l_2	l_3	l_4	l_5	z
3,850 - 4,900	10	80	14	40	40	33	4
4,901 - 6,200	12	85	14	45	40	33	4
6,201 - 6,700	12	105	14	45	60	52	6
6,701 - 8,200	12	110	18	45	65	57	6

Esempio tolleranza IT6:

MRP510Ø5.350H6MG1M-CU178

 Diametro del foro $d_1 = 5,350$ H6

Esempio variante G:

MRP510GØ5.350-3MG1M-CU178

 Diametro utensile speciale $d_1 = 5,350$ -3 μ m

Misure in mm.

 * per superfici $R_a < 2$ μ m

Per i parametri di lavorazione consigliati, vedere la fine del capitolo.

MonoReam Plus

Versione fissa, per foro passante
MRP505

Versione:

Diametro alesatore:

3,850 - 8,200 mm

Imbocco:

MV3C

Materiale da taglio:

CU178

Cermet non rivestito

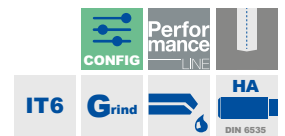
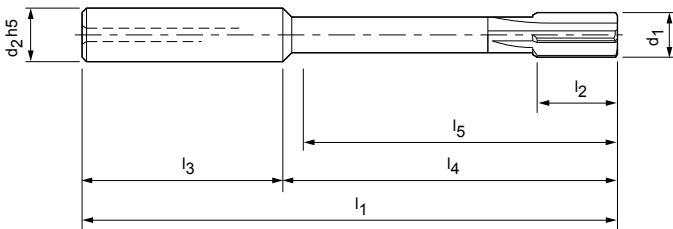
Caratteristiche configurabili

Diametro del foro tolleranza \geq IT6:

- Diametro a libera scelta a passi da 0,001 mm
- Ordinabile in tolleranza \geq IT6

Specifiche:

MRP505Ø[diametro][tolleranza]MV3C-CU178

Variante G:

- Diametro a libera scelta a passi da 0,001 mm
- Ordinabile a partire da una tolleranza \geq 3 μ m (variante G vedere pagina 355)

Specifiche variante G:

MRP505GØ[diametro][tolleranza]MV3C-CU178

Dimensioni serie configurabile IT6

d_1	d_2	l_1	l_2	l_3	l_4	l_5	z
3,850 - 4,900	10	80	12	40	40	33	4
4,901 - 6,200	12	85	12	45	40	33	4
6,201 - 6,700	12	105	12	45	60	53	6
6,701 - 8,200	12	110	16	45	65	58	6

Esempio tolleranza IT6:

MRP505Ø5.350H6MV3C-CU178

 Diametro del foro $d_1 = 5,350$ H6

Esempio variante G:

MRP505Ø5.350-3MV3C-CU178

 Diametro utensile speciale $d_1 = 5,350$ -3 μ m

Misure in mm.

 * per superfici $R_a < 2$ μ m

Per i parametri di lavorazione consigliati, vedere la fine del capitolo.

Parametri di lavorazione consigliati per MonoReam MOR | MonoReam Plus MRP

Avanzamento e velocità di taglio

MRP505 | MRP510

Materiale da taglio: CU178 | Imbocco: MV3C | MG1M

GTM*	Materiale	Resistenza/durezza [N/mm ²] [HRC]	Velocità di taglio v _c (m/min)			
			Adduzione interna del refrigerante	Raffreddamento esterno	MQL	
P	P1.1	Acciai da costruzione, automatici, da cementazione e da bonifica, non legati	< 700	150	75	125
	P1.2	Acciai da costruzione, automatici, da cementazione e da bonifica, non legati	< 1200	150	75	125
	P2.1	Acciai da niturazione, da cementazione e da bonifica, legati	< 900	130	65	110
	P2.2	Acciai da niturazione, da cementazione e da bonifica, legati	< 1400	130	65	110
	P3.1	Acciai per utensili, per cuscinetti volventi, armonici e per lavorazioni veloci**	< 800	130	65	110
	P3.2	Acciai per utensili, per cuscinetti volventi, armonici e per lavorazioni veloci**	< 1000	120	60	100
	P3.3	Acciai per utensili, per cuscinetti volventi, armonici e per lavorazioni veloci**	< 1500			

MOR705 | MOR710

Materiale da taglio: CU130 | Imbocco: MU2A | MY1G

GTM*	Materiale	Resistenza/durezza [N/mm ²] [HRC]	Velocità di taglio v _c (m/min)			
			Adduzione interna del refrigerante	Raffreddamento esterno	MQL	
P	P1.1	Acciai da costruzione, automatici, da cementazione e da bonifica, non legati	< 700	150	75	125
	P1.2	Acciai da costruzione, automatici, da cementazione e da bonifica, non legati	< 1200	150	75	125
	P2.1	Acciai da niturazione, da cementazione e da bonifica, legati	< 900	130	65	110
	P2.2	Acciai da niturazione, da cementazione e da bonifica, legati	< 1400	130	65	110
	P3.1	Acciai per utensili, per cuscinetti volventi, armonici e per lavorazioni veloci**	< 800	130	65	110
	P3.2	Acciai per utensili, per cuscinetti volventi, armonici e per lavorazioni veloci**	< 1000	120	60	100
	P3.3	Acciai per utensili, per cuscinetti volventi, armonici e per lavorazioni veloci**	< 1500			
K	K1.1	Ghisa con grafite lamellare (ghisa grigia), GJL	< 300	120	100	100
	K2.1	Ghisa con grafite sferoidale, GJS	< 500	120	85	105
	K2.2	Ghisa con grafite sferoidale, GJS	≤ 800			
	K2.3	Ghisa con grafite sferoidale, GJS	> 800			

MOR705 | MOR710

Materiale da taglio: HP421 | Imbocco: MU2A | MY1G

GTM*	Materiale	Resistenza/durezza [N/mm ²] [HRC]	Velocità di taglio v _c (m/min)			
			Adduzione interna del refrigerante	Raffreddamento esterno	MQL	
P	P3.1	Acciai per utensili, per cuscinetti volventi, armonici e per lavorazioni veloci**	< 800			
	P3.2	Acciai per utensili, per cuscinetti volventi, armonici e per lavorazioni veloci**	< 1000			
	P3.3	Acciai per utensili, per cuscinetti volventi, armonici e per lavorazioni veloci**	< 1500	100	50	75
	P4.1	Acciai inossidabili, ferritici e martensitici		40	20	30
	P5.1	Acciaio fuso		110	60	80
	P6.1	Acciaio fuso, ferritico e martensitico		40	20	30
K	K1.1	Ghisa con grafite lamellare (ghisa grigia), GJL	< 300	120	100	100
	K2.1	Ghisa con grafite sferoidale, GJS	< 500	110	80	95
	K2.2	Ghisa con grafite sferoidale, GJS	≤ 800	90	65	75
	K2.3	Ghisa con grafite sferoidale, GJS	> 800	90	55	70
	K3.1	Ghisa con grafite vermicolare, GJV; acciaio fuso malleabile, GJM	< 500	90	55	70
	K3.2	Ghisa con grafite vermicolare, GJV; acciaio fuso malleabile, GJM	> 500	90	55	70

* Gruppi di materiale MAPAL

** Qualora la somma dei componenti di lega Cr, Mo, Ni, V, W equivalesse a > 8%, selezionare il gruppo di materiale MAPAL immediatamente superiore.

Avanzamento f_z (mm/z) per il diametro dell'utensile			
	z 4	z 4	z 6
	< 5,000	5,000 - 6,200	> 6,200 - 8,200
	0,025	0,040	0,060
	0,025	0,040	0,060
	0,025	0,040	0,060
	0,025	0,040	0,060
	0,025	0,040	0,060
	0,025	0,040	0,060

Avanzamento f_z (mm/z) per il diametro dell'utensile				
	z 4	z 6	z 6	z 8
	8,000 - 9,700	> 9,700 - 16,000	> 16,000 - 29,200	> 29,200 - 40,200
	0,100	0,150	0,150	0,150
	0,100	0,150	0,150	0,150
	0,100	0,150	0,150	0,150
	0,080	0,120	0,120	0,120
	0,100	0,150	0,150	0,150
	0,100	0,150	0,150	0,150
	0,150	0,200	0,200	0,250
	0,150	0,180	0,180	0,180

Avanzamento f_z (mm/z) per il diametro dell'utensile				
	z 4	z 6	z 6	z 8
	8,000 - 9,700	> 9,700 - 16,000	> 16,000 - 29,200	> 29,200 - 40,200
	0,100	0,150	0,150	0,150
	0,080	0,100	0,120	0,120
	0,150	0,150	0,150	0,150
	0,080	0,100	0,120	0,120
	0,150	0,200	0,200	0,250
	0,150	0,180	0,180	0,180
	0,150	0,180	0,180	0,180
	0,120	0,150	0,150	0,150
	0,150	0,180	0,180	0,180
	0,150	0,150	0,150	0,150

I parametri di lavorazione indicati sono valori orientativi.

I dati ottimali per la specifica applicazione devono essere rilevati eseguendo diversi tentativi o durante l'effettiva lavorazione.

Parametri di lavorazione consigliati per MonoReam MOR

Avanzamento e velocità di taglio

MOR700

Materiale da taglio: HU612 | Imbocco: MY1G

GTM*	Materiale	Resistenza/durezza [N/mm ²] [HRC]	Velocità di taglio v _c (m/min)		
			Adduzione interna del refrigerante	Raffreddamento esterno	MQL
N1	N1.1 Alluminio, non legato e legato < 3% Si		50	25	40
	N1.2 Alluminio, legato ≤ 7% Si		50	25	40
	N1.3 Alluminio, legato > 7-12% Si		30	15	25
	N1.4 Alluminio, legato > 12% Si		30	15	25
N2	N2.1 Rame, non legato e bassolegato	< 300	50	25	
	N2.2 Rame, legato	> 300	50	25	
	N2.3 Ottone, bronzo, ghisa rossa	< 1200	50	25	40
N4	N4.1 Plastica, thermoplast		40	20	
	N4.2 Plastica, duroplast		40	20	
	N4.3 Plastica, materiali espansi		40	20	

MOR705

Materiale da taglio: HU612 | Imbocco: MU2A

GTM*	Materiale	Resistenza/durezza [N/mm ²] [HRC]	Velocità di taglio v _c (m/min)		
			Adduzione interna del refrigerante	Raffreddamento esterno	MQL
N1	N1.1 Alluminio, non legato e legato < 3% Si		50	25	40
	N1.2 Alluminio, legato ≤ 7% Si		50	25	40
	N1.3 Alluminio, legato > 7-12% Si		30	15	25
	N1.4 Alluminio, legato > 12% Si		30	15	25
N2	N2.1 Rame, non legato e bassolegato	< 300	50	25	
	N2.2 Rame, legato	> 300	50	25	
	N2.3 Ottone, bronzo, ghisa rossa	< 1200	50	25	40

	Avanzamento f_z (mm/z) per il diametro dell'utensile			
	z 4	z 6	z 6	z 8
	8,000 - 9,700	> 9,700 - 16,000	> 16,000 - 29,200	> 29,200 - 40,200
	0,050	0,080	0,100	0,120
	0,050	0,080	0,100	0,120
	0,050	0,080	0,100	0,120
	0,050	0,080	0,100	0,120
	0,050	0,080	0,100	0,120
	0,050	0,080	0,100	0,120
	0,050	0,080	0,100	0,120
	0,050	0,080	0,080	0,080
	0,050	0,080	0,080	0,080
	0,050	0,080	0,080	0,080

	Avanzamento f_z (mm/z) per il diametro dell'utensile			
	z 4	z 6	z 6	z 8
	8,000 - 9,700	> 9,700 - 16,000	> 16,000 - 29,200	> 29,200 - 40,200
	0,050	0,080	0,100	0,120
	0,050	0,080	0,100	0,120
	0,050	0,080	0,100	0,120
	0,050	0,080	0,100	0,120
	0,050	0,080	0,100	0,120
	0,050	0,080	0,100	0,120
	0,050	0,080	0,100	0,120

I parametri di lavorazione indicati sono valori orientativi.

I dati ottimali per la specifica applicazione devono essere rilevati eseguendo diversi tentativi o durante l'effettiva lavorazione.

PANORAMICA PRODOTTI

Alesatore a testina intercambiabile HPR

La gamma di alesatori a testa sostituibile HPR comprende serie per fori passanti e ciechi a partire da un diametro di 7,00 mm. Gli alesatori a testa sostituibile sono disponibili sia in versione fissa (serie XX) che in versione finemente regolabile (serie XX) e possono essere dotati di diversi materiali da taglio, come carburo o cermet. Gli alesatori possono essere configurati nella gamma di diametri da 7,00 a 65,00 mm in passi di μm e in un intervallo di tolleranza $\geq \text{IT5}$. Come serie selezionata è disponibile un'ampia gamma di dimensioni H7.

Con il sistema Head Fitting System (HFS), i portautensili associati sono caratterizzati da un'esatta concentricità e da una precisione di commutazione inferiore a $3 \mu\text{m}$ e da una manipolazione semplice e sicura, soprattutto durante il montaggio e lo smontaggio della testa dell'utensile. HFS garantisce un'elevata precisione e trasmissione di potenza. Grazie al design semplice con alimentazione diretta del refrigerante al tagliente, il sistema è condizionatamente adatto alla lubrificazione a quantità minima (MQL).

HPR versione fissa



HPR Serie 100 | 130 | 131 | 110 | 150 | 180

Versione fissa con taglienti brasati.

Range di \varnothing : 7,000 – 65,000 mm*

Perfor
mance
LINE

CONFIG IT G_{grind}

P M K N S



HPR versione con regolazione fine



HPR Serie 200 | 230 | 231 | 210 | 250 | 280

Regolazione con una precisione al μm grazie allo speciale sistema di regolazione.

Range di \varnothing : 7,000 – 65,000 mm*

Expert
LINE

CONFIG IT Grind

P M K N S

Fase 1:
Tipo di foroFase 2:
Idoneità del ma-
terialeFase 3:
VersioneFase 4:
Classe di prodot-
toFase 5:
Diametri preconfigurati o configurazione

	Versione			Diametri preconfigurati				Configurazione
	d1	Materiale da taglio	Imbocco	Perfor- mance LINE	Serie fissa	Expert LINE	Serie con regolazione fine	
				Serie	Pagina	Serie	Pagina	
	7,000 - 18,590	CU134	ME1G	HPR131	379	HPR231	418	HPR131 HPR231
	15,600 - 65,000	CU134	ME1G	HPR110	390	HPR210	426	
	7,000 - 18,590	HP421	ME1G	HPR131	380	HPR231	419	
	15,600 - 65,000	HP421	ME1G	HPR110	392	HPR210	427	
	7,000 - 18,590	HP421	MF1G	HPR131	381	HPR231	420	HPR130 HPR230
	15,600 - 65,000	HP421	MF1G	HPR110	394	HPR210	428	
	7,000 - 18,590	CP134	MC1G	HPR130	374	HPR230	414	
	15,600 - 65,000	CP134	MC1G	HPR100	383	HPR200	422	
	7,000 - 18,590	HC419	MC1G	HPR130	375			HPR100 HPR200
	15,600 - 65,000	HC419	MC1G	HPR100	384			
	7,000 - 18,590	HP421	MC1G	HPR130	376	HPR230	415	
	15,600 - 65,000	HP421	MC1G	HPR100	386	HPR200	423	
	7,000 - 18,590	HP423	MC1G	HPR130	377	HPR230	416	
	15,600 - 65,000	HP423	MC1G	HPR100	388	HPR200	424	
	7,000 - 18,590	PU620	MA0A	HPR130	378	HPR230	417	
	15,600 - 65,000	PU620	MA0A	HPR100	389	HPR200	425	
	7,000 - 18,590	HP625	MF1G	HPR131	382	HPR231	421	
	15,600 - 65,000	HP625	MF1G	HPR110	393	HPR210	431	
	7,000 - 21,290	CU134	ML2G	HPR180	396	HPR280	430	HPR180 HPR280
	16,600 - 65,000	CU134	ML2G	HPR150	405	HPR250	438	
	7,000 - 21,290	HP421	ML2G	HPR180	397	HPR280	431	
	16,600 - 65,000	HP421	ML2G	HPR150	406	HPR250	439	
	7,000 - 21,290	HP421	MO2G	HPR180	398	HPR280	432	
	16,600 - 65,000	HP421	MO2G	HPR150	407	HPR250	440	HPR150 HPR250
	7,000 - 21,290	CP134	MC1G	HPR180	399	HPR280	433	
	16,600 - 65,000	CP134	MC1G	HPR150	408	HPR250	441	
	7,000 - 21,290	HC419	MC1G	HPR180	400			
	16,600 - 65,000	HC419	MC1G	HPR150	403			
	7,000 - 21,290	HP421	MC1G	HPR180	401	HPR280	434	
	16,600 - 65,000	HP421	MC1G	HPR150	410	HPR250	442	
	7,000 - 21,290	HP423	MC1G	HPR180	402	HPR280	435	
	16,600 - 65,000	HP423	MC1G	HPR150	411	HPR250	443	
	7,000 - 21,290	PU620	MA0A	HPR180	403	HPR280	436	
	16,600 - 65,000	PU620	MA0A	HPR150	412	HPR250	444	
	7,000 - 21,290	HP625	MO2G	HPR180	404	HPR280	437	
	16,600 - 65,000	HP625	MO2G	HPR150	413	HPR250	445	

Configurazione serie alla pagina seguente.

Riepilogo dell'assortimento HPR | Configurazione (2/2)

HPR131 | HPR231

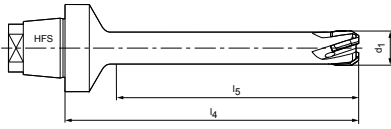

HPR130 | HPR230

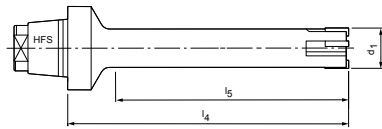

HPR180 | HPR280

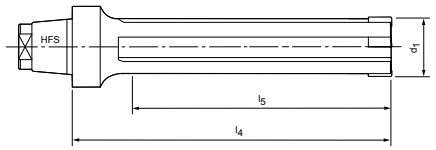

Misure utensili

	∅ _{d1}	l ₄	l ₅	Dimen- sione HFS	z
HPR130 131 HPR230 231	7,000 - 9,590	60	45	12	4
	9,600 - 18,590	60	45	12	6
HPR180 HPR280	7,000 - 14,590	60	40	12	4
	14,600 - 21,290	60	40	12	6
HPR100 HPR110	15,600 - 18,590	14	-	10	6
	18,600 - 21,290	14,5	-	12	6
	21,300 - 23,990	15,5	-	14	6
	24,000 - 29,990	16	-	16	6
	30,000 - 39,990	17	-	20	8
	40,000 - 50,700	19	-	24	8
HPR150	50,710 - 65,000	25	-	24	8
	16,600 - 21,290	14	-	10	6
	21,300 - 24,990	15,5	-	12	6
	25,000 - 28,990	15,5	-	14	6
	29,000 - 36,990	17	-	16	6
	37,000 - 44,990	17	-	20	8
45,000 - 50,700	19	-	24	8	
50,710 - 65,000	25	-	24	8	

	∅ _{d1}	l ₄	l ₅	Dimen- sione HFS	z
HPR200 HPR210	18,600 - 20,390	25	-	12	6
	20,400 - 21,290	27	-	12	6
	21,300 - 23,990	27	-	14	6
	24,000 - 29,990	35	-	16	6
	30,000 - 39,990	41	-	20	8
HPR250	40,000 - 65,000	47	-	24	8
	16,600 - 21,290	25	-	10	6
	21,300 - 24,990	27	-	12	6
	25,000 - 28,590	35	-	14	6
	29,000 - 32,290	35	-	16	6
	32,300 - 36,990	41	-	16	6
	37,000 - 41,190	41	-	20	8
	41,200 - 44,900	47	-	20	8
45,000 - 65,000	47	-	24	8	

Esempio di ordine:

Serie

H P R

Alesatore a testina intercambiabile HPR

Diametro

1 0 0

G

∅ 2 0

. 0 0 0

Diametro foro o utensile

Tolleranza

- 5

IT o misure in µm (esempio: +30+10) oppure, per la variante G, indicazione della tolleranza di produzione del diametro di affilatura utensile ad esempio -3 µm

Versioni:

1 = Alesatore fisso

2 = Alesatore a regolazione fine

Angolo inclinazione dei taglienti:

0 = Con scanalatura dritta fino a ∅ 65,000 mm

1 = Con scanalatura obliqua sinistra fino a ∅ 65,000 mm

3 = Obliqua sinistra fino a ∅ 18,590 mm

5 = Foro cieco fino a ∅ 65,000 mm

8 = Foro cieco fino a ∅ 21,290 mm

G = Indicazione del diametro utensile

Indicazione data solo per le varianti C e G

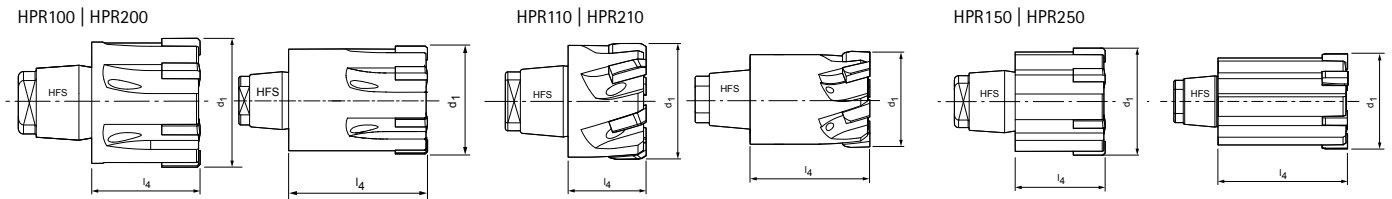

Tolleranze ammesse sul pezzo per la selezione del diametro utensile:

Versione fissa:

IT6 (16µm) oltre $\geq \varnothing 30,000$ HPR

Nel caso in cui la tolleranza fosse inferiore rispetto al diametro utensile da lavorare, come per la classe di tolleranza sopra menzionata, si può optare per una versione con regolazione fine o una versione fissa in variante G (diametro utensile speciale).

Versione con regolazione fine:

IT5 (11µm) oltre $\geq \varnothing 30,000$ HPR

Nel caso in cui la tolleranza fosse inferiore rispetto al diametro utensile da lavorare, come per la classe di tolleranza sopra menzionata, si può optare per una versione con regolazione fine in variante G (diametro utensile speciale).

Versione variante G

La variante G indica il diametro dell'utensile dell'alesatore con le nostre tolleranze di produzione.

Tolleranze per la variante G/variante fissa HPR1XX:

Materiale da taglio	Range di diametro	
	$\varnothing 7 - < \varnothing 60$	$\geq \varnothing 60 - \varnothing 65$
Non rivestito		
HU612		
CU134	-0,003	-0,006
CU130		
PU620		
Rivestito (spessore strato 1 - 2 µm)		
HP421		
CP134	-0,005	-0,008
HP625		
Rivestito (spessore strato 2 - 4 µm)		
HP423		
HP463	-0,008	-0,010
CP132		
CP233		
Rivestito (spessore strato 3 - 5 µm)		
HC412		
HC413	-0,007	-0,010
HC419		

Tolleranze per la variante G/variante con regolazione fine HPR2XX:
valore di impostazione generale +/-0,001

Imbocco [Lead]

M C 1 G

Forma di imbocco e
angolo di spoglia:

MC1G ME1G Per la spiegazione
MA0A ML2G delle geometrie di
MO2G MF1G imbocco vedere pagina 752.

Materiale da taglio [Cut]

H P 4 2 1

Materiale da taglio:

HP421 CU134
HP422 HP625
HP423 HC419
CP134 PU620

Alesatore a testina intercambiabile HPR

Versione fissa con scanalatura dritta, per foro passante
HPR130

Versione:

Diametro alesatore:

7,000 - 18,590 mm

Imbocco:

MC1G

Materiale da taglio:

CP134

Cermet rivestito in

PVD

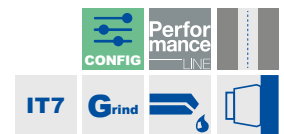
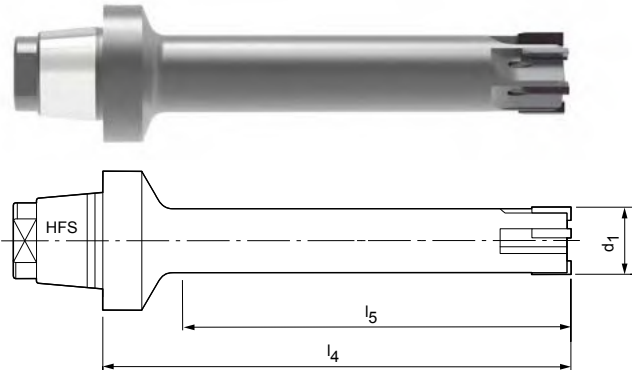

Caratteristiche configurabili

Diametro del foro tolleranza IT7:

- Diametro a libera scelta a passi da 0,001 mm
- Ordinabile in tolleranza IT7

Specifiche:

HPR130Ø[diametro][tolleranza]MC1G-CP134

Diametro del foro tolleranza < IT7:

- Tolleranze inferiori a IT7 ordinabili come diametro utensile speciale (per variante G vedere pagina 373)

Specifiche variante G:

HPR130GØ[diametro][tolleranza]MC1G-CP134

Dimensioni serie configurabile IT7

d_1	l_4	l_5	Dimensione HFS	z
7,000 - 9,590	60	45	12	4
9,600 - 18,590	60	45	12	6

Esempio tolleranza IT7:

HPR130Ø16.350H7MC1G-CP134

 Diametro del foro $d_1 = 16,350$ H7

Esempio variante G:

HPR130GØ16.350-5MC1G-CP134

 Diametro utensile speciale $d_1 = 16,350$ -5 μm

Misure in mm.

 * per superfici $R_a < 2 \mu\text{m}$

Supporto per testina intercambiabile HFS da pagina 460.

Per i parametri di lavorazione consigliati, vedere la fine del capitolo.

Alesatore a testina intercambiabile HPR

Versione fissa con scanalatura dritta, per foro passante
HPR130

Versione:

Diametro alesatore:

7,000 - 18,590 mm

Imbocco:

MC1G

Materiale da taglio:

Metallo duro rivestito

in CVD

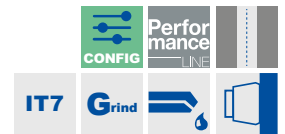
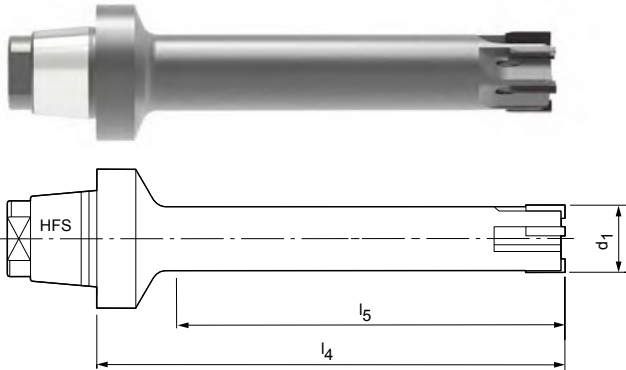

Caratteristiche configurabili

Diametro del foro tolleranza IT7:

- Diametro a libera scelta a passi da 0,001 mm
- Ordinabile in tolleranza IT7

Specifiche:

HPR130Ø[diametro][tolleranza]MC1G-HC419

Diametro del foro tolleranza < IT7:

- Tolleranze inferiori a IT7 ordinabili come diametro utensile speciale (per variante G vedere pagina 373)

Specifiche variante G:

HPR130GØ[diametro][tolleranza]MC1G-HC419

Dimensioni serie configurabile IT7

d ₁	l ₄	l ₅	Dimensione HFS	z
7,000 - 9,590	60	45	12	4
9,600 - 18,590	60	45	12	6

Esempio tolleranza IT7:

HPR130Ø16.350H7MC1G-HC419

 Diametro del foro d₁ = 16,350 H7

Esempio variante G:

HPR130GØ16.350-7MC1G-HC419

 Diametro utensile speciale d₁ = 16,350 -7 µm

Misure in mm.

 * per superfici R_a < 2 µm

Supporto per testina intercambiabile HFS da pagina 460.

Per i parametri di lavorazione consigliati, vedere la fine del capitolo.

Alesatore a testina intercambiabile HPR

Versione fissa con scanalatura dritta, per foro passante
HPR130

Versione:

Diametro alesatore:

7,000 - 18,590 mm

Imbocco:

MC1G

Materiale da taglio:

metallo duro rivestito

in PVD

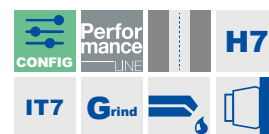
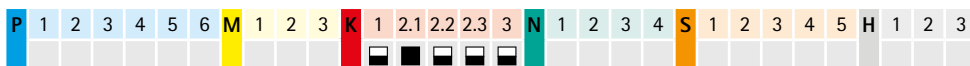
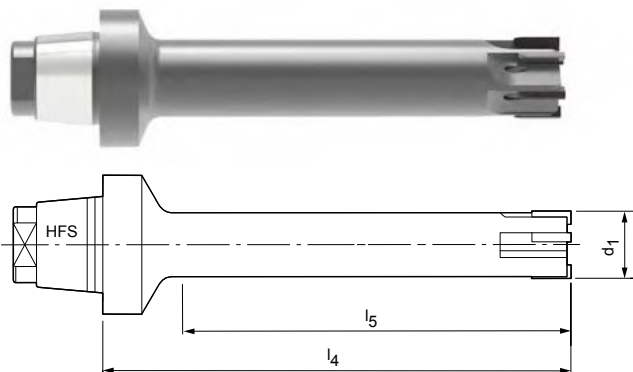
Serie selezionata per il magazzino in H7

d ₁ H7	Dimensione HFS	Dimensioni			Specifiche	Codice
		l ₄	l ₅	z		
10,000	12	60	45	6	HPR130Ø10H7MC1G-HP421	30058428
12,000	12	60	45	6	HPR130Ø12H7MC1G-HP421	30201261
14,000	12	60	45	6	HPR130Ø14H7MC1G-HP421	30710146
16,000	12	60	45	6	HPR130Ø16H7MC1G-HP421	30710148
18,000	12	60	45	6	HPR130Ø18H7MC1G-HP421	30156684

Caratteristiche configurabili

Diametro del foro tolleranza IT7:

- Diametro a libera scelta a passi da 0,001 mm
- Ordinabile in tolleranza IT7

Specifiche:

HPR130Ø[diametro][tolleranza]MC1G-HP421

Diametro del foro tolleranza < IT7:

- Tolleranze inferiori a IT7 ordinabili come diametro utensile speciale (per variante G vedere pagina 373)

Specifiche variante G:

HPR130GØ[diametro][tolleranza]MC1G-HP421

Dimensioni serie configurabile IT7

d ₁	l ₄	l ₅	Dimensione HFS	z
7,000 - 9,590	60	45	12	4
9,600 - 18,590	60	45	12	6

Esempio tolleranza IT7:

HPR130Ø16.350H7MC1G-HP421

 Diametro del foro d₁ = 16,350 H7

Esempio variante G:

HPR130GØ16.350-5MC1G-HP421

 Diametro utensile speciale d₁ = 16,350 -5 µm

Misure in mm.

Supporto per testina intercambiabile HFS da pagina 460.

Per i parametri di lavorazione consigliati, vedere la fine del capitolo.

Alesatore a testina intercambiabile HPR

Versione fissa con scanalatura dritta, per foro passante
HPR130

Versione:

Diametro alesatore:

7,000 - 18,590 mm

Imbocco:

MC1G

Materiale da taglio:

HP423

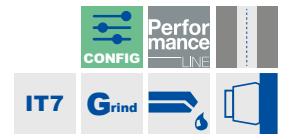
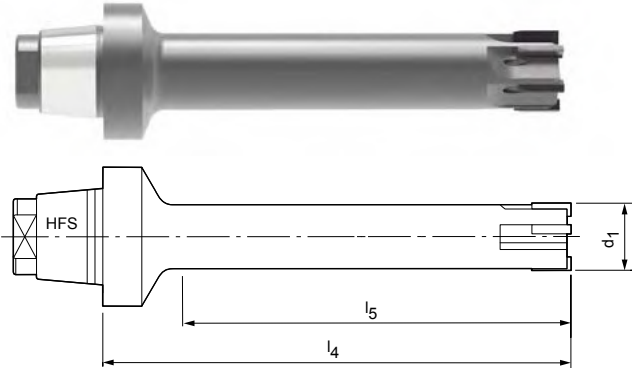
 metallo duro rivestito
in PVD

Caratteristiche configurabili

Diametro del foro tolleranza IT7:

- Diametro a libera scelta a passi da 0,001 mm
- Ordinabile in tolleranza IT7

Specifiche:

HPR130Ø[diametro][tolleranza]MC1G-HP423

Diametro del foro tolleranza < IT7:

- Tolleranze inferiori a IT7 ordinabili come diametro utensile speciale (per variante G vedere pagina 373)

Specifiche variante G:

HPR130GØ[diametro][tolleranza]MC1G-HP423

Dimensioni serie configurabile IT7

d_1	l_4	l_5	Dimensione HFS	z
7,000 - 9,590	60	45	12	4
9,600 - 18,590	60	45	12	6

Esempio tolleranza IT7:

HPR130Ø16.350H7MC1G-HP423

 Diametro del foro $d_1 = 16,350 \text{ H7}$
Esempio variante G:

HPR130GØ16.350-8MC1G-HP423

 Diametro utensile speciale $d_1 = 16,350 -8 \mu\text{m}$

Misure in mm.

Supporto per testina intercambiabile HFS da pagina 460.

Per i parametri di lavorazione consigliati, vedere la fine del capitolo.

Alesatore a testina intercambiabile HPR

Versione fissa con scanalatura dritta, per foro passante
HPR130

Versione:

Diametro alesatore:

7,000 - 18,590 mm

Imbocco:

MA0A

Materiale da taglio:

PU620

Con riporto in PCD

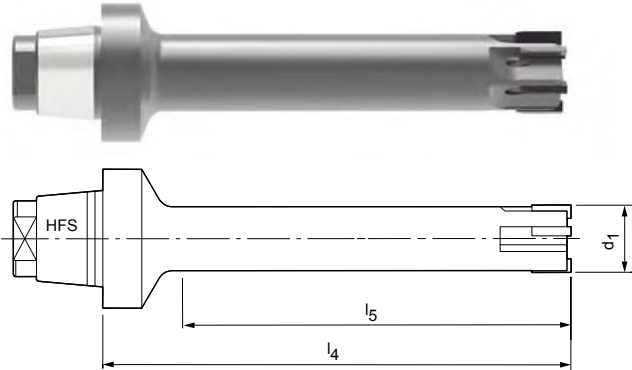

Caratteristiche configurabili

Diametro del foro tolleranza IT7:

- Diametro a libera scelta a passi da 0,001 mm
- Ordinabile in tolleranza IT7

Specifiche:

HPR130Ø[diametro][tolleranza]MA0A-PU620

Diametro del foro tolleranza < IT7:

- Tolleranze inferiori a IT7 ordinabili come diametro utensile speciale (per variante G vedere pagina 373)

Specifiche variante G:

HPR130GØ[diametro][tolleranza]MA0A-PU620

Dimensioni serie configurabile IT7

d_1	l_4	l_5	Dimensione HFS	z
7,000 - 9,590	60	45	12	4
9,600 - 18,590	60	45	12	6

Esempio tolleranza IT7:

HPR130Ø16.350H7MA0A-PU620

 Diametro del foro $d_1 = 16,350 \text{ H7}$
Esempio variante G:

HPR130GØ16.350-3MA0A-PU620

 Diametro utensile speciale $d_1 = 16,350 -3 \mu\text{m}$

Misure in mm.

Supporto per testina intercambiabile HFS da pagina 460.

Per i parametri di lavorazione consigliati, vedere la fine del capitolo.

Alesatore a testina intercambiabile HPR

Versione fissa con scanalatura obliqua sinistra, per foro passante
HPR131

Versione:

Diametro alesatore:

7,000 - 18,590 mm

Imbocco:

ME1G

Materiale da taglio:

CU134

Cermet non rivestito

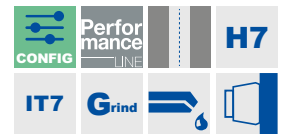
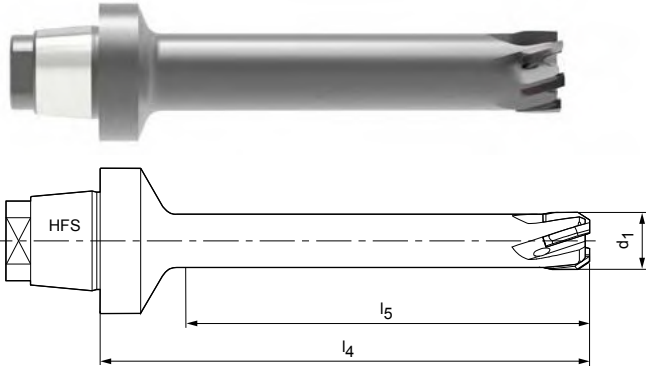

Serie selezionata per il magazzino in H7

d ₁ H7	Dimensione HFS	Dimensioni			Specifiche	Codice
		l ₄	l ₅	z		
10,000	12	60	45	6	HPR131Ø10H7ME1G-CU134	30043741
11,000	12	60	45	6	HPR131Ø11H7ME1G-CU134	30087260
12,000	12	60	45	6	HPR131Ø12H7ME1G-CU134	30041656
13,000	12	60	45	6	HPR131Ø13H7ME1G-CU134	30057835
14,000	12	60	45	6	HPR131Ø14H7ME1G-CU134	30082580
16,000	12	60	45	6	HPR131Ø16H7ME1G-CU134	30047996
18,000	12	60	45	6	HPR131Ø18H7ME1G-CU134	30048997

Caratteristiche configurabili

Diametro del foro tolleranza IT7:

- Diametro a libera scelta a passi da 0,001 mm
- Ordinabile in tolleranza IT7

Specifiche:

HPR131Ø[diametro][tolleranza]ME1G-CU134

Diametro del foro tolleranza < IT7:

- Tolleranze inferiori a IT7 ordinabili come diametro utensile speciale (per variante G vedere pagina 373)

Specifiche variante G:

HPR131GØ[diametro][tolleranza]ME1G-CU134

Dimensioni serie configurabile IT7

d ₁	l ₄	l ₅	Dimensione HFS	z
7,000 - 9,590	60	45	12	4
9,600 - 18,590	60	45	12	6

Esempio tolleranza IT7:

HPR131Ø16.350H7ME1G-CU134

 Diametro del foro d₁ = 16,350 H7

Esempio variante G:

HPR131GØ16.350-3ME1G-CU134

 Diametro utensile speciale d₁ = 16,350 -3 µm

Misure in mm.

Supporto per testina intercambiabile HFS da pagina 460.

Per i parametri di lavorazione consigliati, vedere la fine del capitolo.

Alesatore a testina intercambiabile HPR

Versione fissa con scanalatura obliqua sinistra, per foro passante
HPR131

Versione:

Diametro alesatore:

7,000 - 18,590 mm

Imbocco:

ME1G

Materiale da taglio:

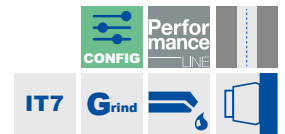
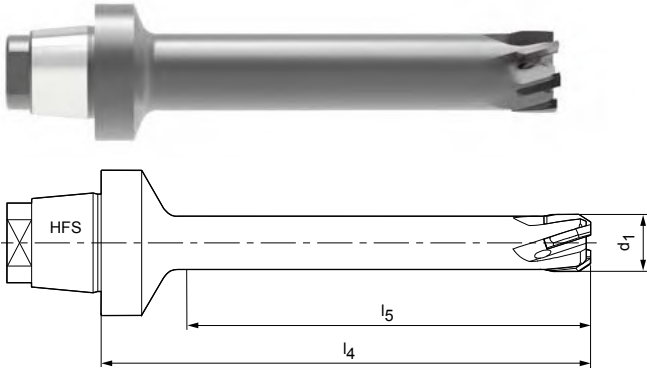
 HP421
 metallo duro rivestito
 in PVD

Caratteristiche configurabili

Diametro del foro tolleranza IT7:

- Diametro a libera scelta a passi da 0,001 mm
- Ordinabile in tolleranza IT7

Specifiche:

HPR131Ø[diametro][tolleranza]ME1G-HP421

Diametro del foro tolleranza < IT7:

- Tolleranze inferiori a IT7 ordinabili come diametro utensile speciale (per variante G vedere pagina 373)

Specifiche variante G:

HPR131GØ[diametro][tolleranza]ME1G-HP421

Dimensioni serie configurabile IT7

d ₁	l ₄	l ₅	Dimensione HFS	z
7,000 - 9,590	60	45	12	4
9,600 - 18,590	60	45	12	6

Esempio tolleranza IT7:

HPR131Ø16.350H7ME1G-HP421

 Diametro del foro d₁ = 16,350 H7

Esempio variante G:

HPR131GØ16.350-5ME1G-HP421

 Diametro utensile speciale d₁ = 16,350 -5 µm

Misure in mm.

Supporto per testina intercambiabile HFS da pagina 460.

Per i parametri di lavorazione consigliati, vedere la fine del capitolo.

Alesatore a testina intercambiabile HPR

Versione fissa con scanalatura obliqua sinistra, per foro passante
HPR131

Versione:

Diametro alesatore:

7,000 - 18,590 mm

Imbocco:

MF1G

Materiale da taglio:

HP421

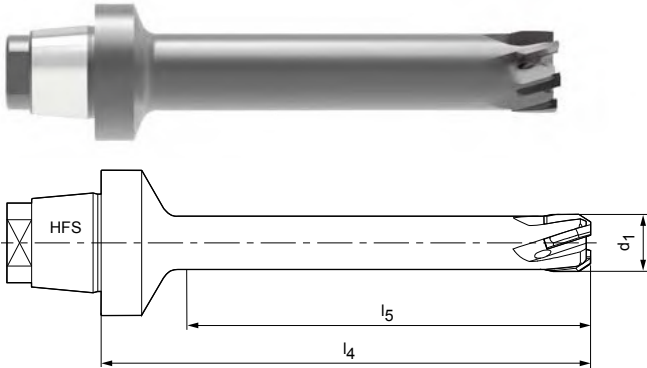
 metallo duro rivestito
in PVD

Serie privilegiata in stock in H7

d ₁ H7	Dimensione HFS	Dimensioni della costruzione			Specifiche	Codice
		l ₄	l ₅	z		
10,000	12	60	45	6	HPR131Ø10.0H7MF1G-HP421	30710160
11,000	12	60	45	6	HPR131Ø11.00H7MF1G-HP421	30710161
12,000	12	60	45	6	HPR131Ø12.00H7MF1G-HP421	30710162
13,000	12	60	45	6	HPR131Ø13.00H7MF1G-HP421	30710163
14,000	12	60	45	6	HPR131Ø14.00H7MF1G-HP421	30710164
16,000	12	60	45	6	HPR131Ø16.00H7MF1G-HP421	30710166
18,000	12	60	45	6	HPR131Ø18.00H7MF1G-HP421	30710168

Caratteristiche configurabili

Diametro del foro tolleranza IT7:

- Diametro a libera scelta a passi da 0,001 mm
- Ordinabile in tolleranza IT7

Specifiche:

HPR131Ø[diametro][tolleranza]MF1G-HP421

Diametro del foro tolleranza < IT7:

- Tolleranze inferiori a IT7 ordinabili come diametro utensile speciale (per variante G vedere pagina 373)

Specifiche variante G:

HPR131GØ[diametro][tolleranza]MF1G-HP421

Dimensioni serie configurabile IT7

d ₁	l ₄	l ₅	Dimensione HFS	z
7,000 - 9,590	60	45	12	4
9,600 - 18,590	60	45	12	6

Esempio tolleranza IT7:

HPR131Ø16.350H7MF1G-HP421

 Diametro del foro d₁ = 16,350 H7

Esempio variante G:

HPR131GØ16.350-5MF1G-HP421

 Diametro utensile speciale d₁ = 16,350 -5 µm

Misure in mm.

Supporto per testina intercambiabile HFS da pagina 460.

Per i parametri di lavorazione consigliati, vedere la fine del capitolo.

Alesatore a testina intercambiabile HPR

Versione fissa con scanalatura obliqua sinistra, per foro passante
HPR131

Versione:

Diametro alesatore:

7,000 - 18,590 mm

Imbocco:

MF1G

Materiale da taglio:

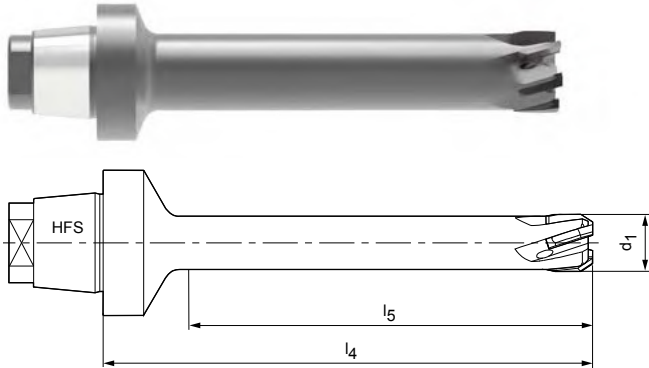
 HP625
metallo duro rivestito
in PVD

Caratteristiche configurabili

Diametro del foro tolleranza IT7:

- Diametro a libera scelta a passi da 0,001 mm
- Ordinabile in tolleranza IT7

Specifiche:

HPR131Ø[diametro][tolleranza]MF1G-HP625

Diametro del foro tolleranza < IT7:

- Tolleranze inferiori a IT7 ordinabili come diametro utensile speciale (per variante G vedere pagina 373)

Specifiche variante G:

HPR131GØ[diametro][tolleranza]MF1G-HP625

Dimensioni serie configurabile IT7

d_1	l_4	l_5	Dimensione HFS	z
7,000 - 9,590	60	45	12	4
9,600 - 18,590	60	45	12	6

Esempio tolleranza IT7:

HPR131Ø16.350H7MF1G-HP625

 Diametro del foro $d_1 = 16,350$ H7

Esempio variante G:

HPR131GØ16.350-7MF1G-HP625

 Diametro utensile speciale $d_1 = 16,350$ -5 μm

Misure in mm.

Supporto per testina intercambiabile HFS da pagina 460.

Per i parametri di lavorazione consigliati, vedere la fine del capitolo.

Alesatore a testina intercambiabile HPR

Versione fissa con scanalatura dritta, per foro passante
HPR100

Versione:

Diametro alesatore:

15,600 - 65,000 mm

Imbocco:

MC1G

Materiale da taglio:

CP134

Cermet rivestito in

PVD

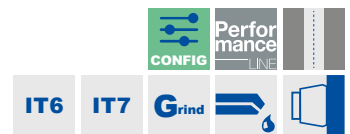
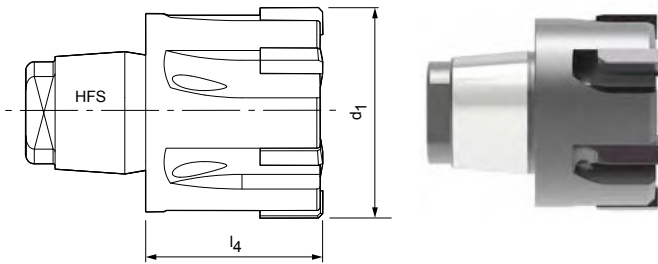

Caratteristiche configurabili



Diametro del foro tolleranza IT6/IT7:

- Diametro a libera scelta a passi da 0,001 mm
- Ordinabile in funzione del range di diametro a partire da tolleranze IT6/IT7
- > Ø30,000 IT6 | ≤ Ø30,000 IT7

Specifiche:

HPR100Ø[diametro][tolleranza]MC1G-CP134

Diametro del foro tolleranza < IT6/IT7:

- Tolleranze inferiori a IT6/IT7 ordinabili come diametro utensile speciale (per variante G vedere pagina 373)

Specifiche variante G:

HPR100GØ[diametro][tolleranza]MC1G-CP134

Dimensioni serie configurabile IT6/IT7

d1	l ₄	l ₅	Dimensione HFS	z	Tolleranza
15,600 - 18,590	14	-	10	6	IT7
18,600 - 21,290	14,5	-	12	6	IT7
21,300 - 23,990	15,5	-	14	6	IT7
24,000 - 29,990	16	-	16	6	IT7
30,000 - 39,990	17	-	20	8	IT6
40,000 - 50,700	19	-	24	8	IT6
50,710 - 65,000	25	-	24	8	IT6

Esempio tolleranza IT7:

HPR100Ø16.350H7MC1G-CP134

 Diametro del foro d₁ = 16,350 H7

Esempio variante G:

HPR100GØ16.350-5MC1G-CP134

 Diametro utensile speciale d₁ = 16,350 -5 µm

Misure in mm.

 * per superfici R_a < 2 µm

Supporto per testina intercambiabile HFS da pagina 460.

Per i parametri di lavorazione consigliati, vedere la fine del capitolo.

Alesatore a testina intercambiabile HPR

Versione fissa con scanalatura dritta, per foro passante
HPR100

Versione:

Diametro alesatore:

15,600 - 65,000 mm

Imbocco:

MC1G

Materiale da taglio:

Metallo duro rivestito

in CVD

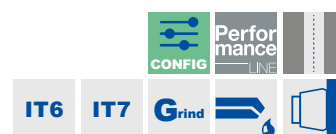
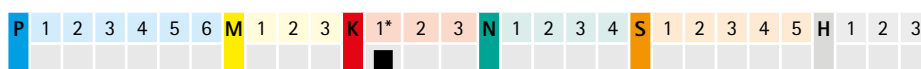
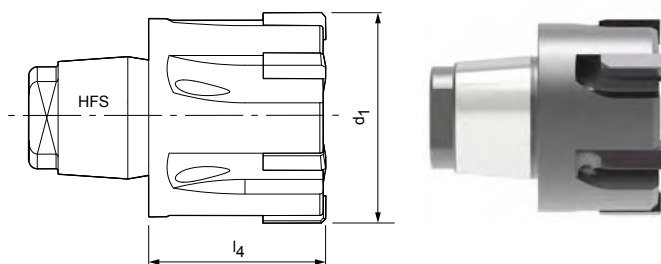

Caratteristiche configurabili

Diametro del foro tolleranza IT6/IT7:

- Diametro a libera scelta a passi da 0,001 mm
- Ordinabile in funzione del range di diametro a partire da tolleranze IT6/IT7
- > Ø30,000 IT6 | ≤ Ø30,000 IT7

Specifiche:

HPR100Ø[diametro][tolleranza]MC1G-HC419

Diametro del foro tolleranza < IT6/IT7:

- Tolleranze inferiori a IT6/IT7 ordinabili come diametro utensile speciale (per variante G vedere pagina 373)

Specifiche variante G:

HPR100GØ[diametro][tolleranza]MC1G-HC419

Dimensioni serie configurabile IT6/IT7

d1	l ₄	l ₅	Dimensione HFS	z	Tolleranza
15,600 - 18,590	14	-	10	6	IT7
18,600 - 21,290	14,5	-	12	6	IT7
21,300 - 23,990	15,5	-	14	6	IT7
24,000 - 29,990	16	-	16	6	IT7
30,000 - 39,990	17	-	20	8	IT6
40,000 - 50,700	19	-	24	8	IT6
50,710 - 65,000	25	-	24	8	IT6

Esempio tolleranza IT7:

HPR100Ø16.350H7MC1G-HC419

 Diametro del foro d₁ = 16,350 H7

Esempio variante G:

HPR100GØ16.350-7MC1G-HC419

 Diametro utensile speciale d₁ = 16,350 -7 µm

Misure in mm.

* per superfici Ra > 2 µm

Supporto per testina intercambiabile HFS da pagina 460.

Per i parametri di lavorazione consigliati, vedere la fine del capitolo.



Alesatore a testina intercambiabile HPR

Versione fissa con scanalatura dritta, per foro passante
HPR100

Versione:

Diametro alesatore:

15,600 - 65,000 mm

Imbocco:

MC1G

Materiale da taglio:

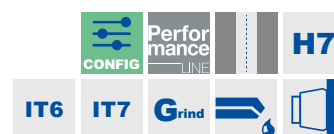
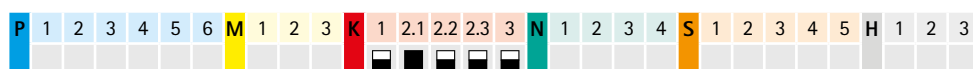
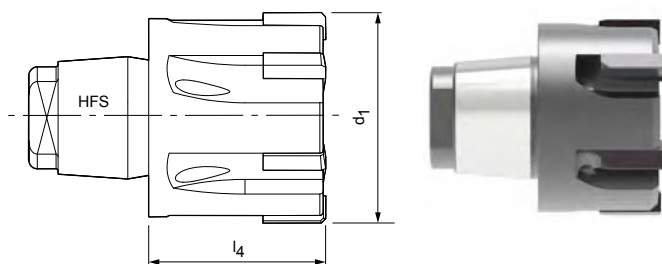
 HP421
 metallo duro rivestito
 in PVD

Serie selezionata per il magazzino in H7

d ₁ H7	Dimensione HFS	Dimensioni		Specifiche	Codice
		l ₄	z		
19,000	12	14,5	6	HPR100Ø19H7MC1G-HP421	30037777
20,000	12	14,5	6	HPR100Ø20H7MC1G-HP421	30191340
22,000	14	15,5	6	HPR100Ø22H7MC1G-HP421	30368857
24,000	16	16	6	HPR100Ø24H7MC1G-HP421	30181729
25,000	16	16	6	HPR100Ø25H7MC1G-HP421	30537929
26,000	16	16	6	HPR100Ø26H7MC1G-HP421	30076945
28,000	16	16	6	HPR100Ø28H7MC1G-HP421	30025212
30,000	20	17	8	HPR100Ø30H7MC1G-HP421	30031345
32,000	20	17	8	HPR100Ø32H7MC1G-HP421	30438453
35,000	20	17	8	HPR100Ø35H7MC1G-HP421	30537930
40,000	24	19	8	HPR100Ø40H7MC1G-HP421	30083953
45,000	24	19	8	HPR100Ø45H7MC1G-HP421	30537931
50,000	24	19	8	HPR100Ø50H7MC1G-HP421	30710245
55,000	24	25	8	HPR100Ø55H7MC1G-HP421	30419154
60,000	24	25	8	HPR100Ø60H7MC1G-HP421	30350208
65,000	24	25	8	HPR100Ø65H7MC1G-HP421	30272888

Misure in mm.

Supporto per testina intercambiabile HFS da pagina 460.

Per i parametri di lavorazione consigliati, vedere la fine del capitolo.

HPR100 | Versione fissa con scanalatura dritta

Caratteristiche configurabili

**Diametro del foro tolleranza IT6/IT7:**

- Diametro a libera scelta a passi da 0,001 mm
- Ordinabile in funzione del range di diametro a partire da tolleranze IT6/IT7
- > Ø30,000 IT6 | ≤ Ø30,000 IT7

Specifiche:

HPR100Ø[diametro][tolleranza]MC1G-HP421

Diametro del foro tolleranza < IT6/IT7:

- Tolleranze inferiori a IT6/IT7 ordinabili come diametro utensile speciale (per variante G vedere pagina 373)

Specifiche variante G:

HPR100GØ[diametro][tolleranza]MC1G-HP421

Dimensioni serie configurabile IT6/IT7

d1	l ₄	l ₅	Dimensione HFS	z	Tolleranza
15,600 - 18,590	14	-	10	6	IT7
18,600 - 21,290	14,5	-	12	6	IT7
21,300 - 23,990	15,5	-	14	6	IT7
24,000 - 29,990	16	-	16	6	IT7
30,000 - 39,990	17	-	20	8	IT6
40,000 - 50,700	19	-	24	8	IT6
50,710 - 65,000	25	-	24	8	IT6

Esempio tolleranza IT7:

HPR100Ø16.350H7MC1G-HP421

Diametro del foro d₁ = 16,350 H7**Esempio variante G:**

HPR100GØ16.350-5MC1G-HP421

Diametro utensile speciale d₁ = 16,350 -5 µm

Alesatore a testina intercambiabile HPR

Versione fissa con scanalatura dritta, per foro passante
HPR100

Versione:
 Diametro alesatore: 15,600 - 65,000 mm
 Imbocco: MC1G
 Materiale da taglio: HP423
 metallo duro rivestito
 in PVD

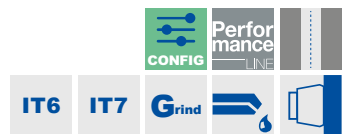
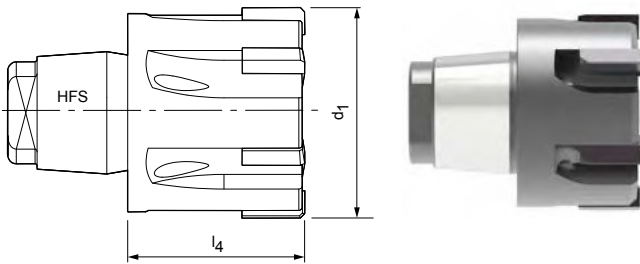

Caratteristiche configurabili



Diametro del foro tolleranza IT6/IT7:

- Diametro a libera scelta a passi da 0,001 mm
- Ordinabile in funzione del range di diametro a partire da tolleranze IT6/IT7
- > Ø30,000 IT6 | ≤ Ø30,000 IT7

Specifiche:

HPR100Ø[diametro][tolleranza]MC1G-HP423

Diametro del foro tolleranza < IT6/IT7:

- Tolleranze inferiori a IT6/IT7 ordinabili come diametro utensile speciale (per variante G vedere pagina 373)

Specifiche variante G:

HPR100GØ[diametro][tolleranza]MC1G-HP423

Dimensioni serie configurabile IT6/IT7

d1	l4	l5	Dimensione HFS	z	Tolleranza
15,600 - 18,590	14	-	10	6	IT7
18,600 - 21,290	14,5	-	12	6	IT7
21,300 - 23,990	15,5	-	14	6	IT7
24,000 - 29,990	16	-	16	6	IT7
30,000 - 39,990	17	-	20	8	IT6
40,000 - 50,700	19	-	24	8	IT6
50,710 - 65,000	25	-	24	8	IT6

Esempio tolleranza IT7:

HPR100Ø16.350H7MC1G-HP423

Diametro del foro d₁ = 16,350 H7

Esempio variante G:

HPR100GØ16.350-8MC1G-HP423

Diametro utensile speciale d₁ = 16,350 -7 µm

Misure in mm.

Supporto per testina intercambiabile HFS da pagina 460.

Per i parametri di lavorazione consigliati, vedere la fine del capitolo.

Alesatore a testina intercambiabile HPR

Versione fissa con scanalatura dritta, per foro passante
HPR100

Versione:

Diametro alesatore:

15,600 - 65,000 mm

Imbocco:

MA0A

Materiale da taglio:

PU620

Con riporto in PCD

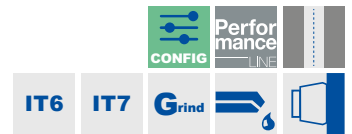
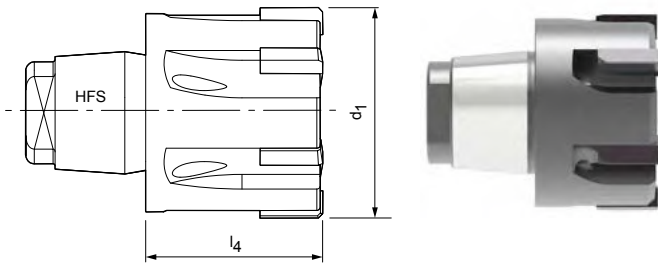
Caratteristiche configurabili

Diametro del foro tolleranza IT6/IT7:

- Diametro a libera scelta a passi da 0,001 mm
- Ordinabile in funzione del range di diametro a partire da tolleranze IT6/IT7
- > Ø30,000 IT6 | ≤ Ø30,000 IT7

Specifiche:

HPR100Ø[diametro][tolleranza]MA0A-PU620

Diametro del foro tolleranza < IT6/IT7:

- Tolleranze inferiori a IT6/IT7 ordinabili come diametro utensile speciale (per variante G vedere pagina 373)

Specifiche variante G:

HPR100GØ[diametro][tolleranza]MA0A-PU620

Dimensioni serie configurabile IT6/IT7

d1	l ₄	l ₅	Dimensione HFS	z	Tolleranza
15,600 - 18,590	14	-	10	6	IT7
18,600 - 21,290	14,5	-	12	6	IT7
21,300 - 23,990	15,5	-	14	6	IT7
24,000 - 29,990	16	-	16	6	IT7
30,000 - 39,990	17	-	20	8	IT6
40,000 - 50,700	19	-	24	8	IT6
50,710 - 65,000	25	-	24	8	IT6

Esempio tolleranza IT7:

HPR100Ø16.350H7MA0A-PU620

 Diametro del foro d₁ = 16,350 H7

Esempio variante G:

HPR100GØ16.350-3MA0A-PU620

 Diametro utensile speciale d₁ = 16,350 -3 µm

Misure in mm.

Supporto per testina intercambiabile HFS da pagina 460.

Per i parametri di lavorazione consigliati, vedere la fine del capitolo.

Alesatore a testina intercambiabile HPR

Versione fissa con scanalatura obliqua sinistra, per foro passante
HPR110

Versione:

Diametro alesatore:

15,600 - 65,000 mm

Imbocco:

ME1G

Materiale da taglio:

CU134

Cermet non rivestito

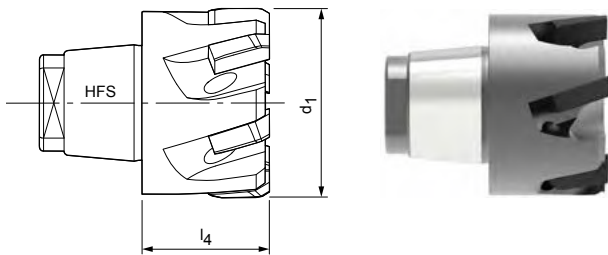

Serie selezionata per il magazzino in H7

d ₁ H7	Dimensione HFS	Dimensioni		Specifiche	Codice
		l ₄	z		
19,000	12	14,5	6	HPR110019H7ME1G-CU134	30077358
20,000	12	14,5	6	HPR110020H7ME1G-CU134	30040404
21,000	12	14,5	6	HPR110021H7ME1G-CU134	30039919
22,000	14	15,5	6	HPR110022H7ME1G-CU134	30081546
23,000	14	15,5	6	HPR110023H7ME1G-CU134	30085368
24,000	16	16	6	HPR110024H7ME1G-CU134	30080958
25,000	16	16	6	HPR110025H7ME1G-CU134	30076110
26,000	16	16	6	HPR110026H7ME1G-CU134	30045730
27,000	16	16	6	HPR110027H7ME1G-CU134	30087257
28,000	16	16	6	HPR110028H7ME1G-CU134	30046121
30,000	20	17	8	HPR110030H7ME1G-CU134	30045095
31,000	20	17	8	HPR110031H7ME1G-CU134	30192960
32,000	20	17	8	HPR110032H7ME1G-CU134	30084530
33,000	20	17	8	HPR110033H7ME1G-CU134	30162282
34,000	20	17	8	HPR110034H7ME1G-CU134	30043743
35,000	20	17	8	HPR110035H7ME1G-CU134	30084885
39,000	20	17	8	HPR110039H7ME1G-CU134	30088042
40,000	24	19	8	HPR110040H7ME1G-CU134	30045097
42,000	24	19	8	HPR110042H7ME1G-CU134	30080437
44,000	24	19	8	HPR110044H7ME1G-CU134	30097178
45,000	24	19	8	HPR110045H7ME1G-CU134	30049313
50,000	24	19	8	HPR110050H7ME1G-CU134	30219386
55,000	24	25	8	HPR110055H7ME1G-CU134	30196567
60,000	24	25	8	HPR110060H7ME1G-CU134	30242416
65,000	24	25	8	HPR110065H7ME1G-CU134	30236537

Misure in mm.

Supporto per testina intercambiabile HFS da pagina 460.

Per i parametri di lavorazione consigliati, vedere la fine del capitolo.

HPR110 | Versione fissa, con scanalatura obliqua sinistra

Caratteristiche configurabili

**Diametro del foro tolleranza IT6/IT7:**

- Diametro a libera scelta a passi da 0,001 mm
- Ordinabile in funzione del range di diametro a partire da tolleranze IT6/IT7
- > Ø30,000 IT6 | ≤ Ø30,000 IT7

Specifiche:

HPR110Ø[diametro][tolleranza]ME1G-CU134

Diametro del foro tolleranza < IT6/IT7:

- Tolleranze inferiori a IT6/IT7 ordinabili come diametro utensile speciale (per variante G vedere pagina 373)

Specifiche variante G:

HPR110GØ[diametro][tolleranza]ME1G-CU134

Dimensioni serie configurabile IT6/IT7

d1	l ₄	l ₅	Dimensione HFS	z	Tolleranza
15,600 - 18,590	14	-	10	6	IT7
18,600 - 21,290	14,5	-	12	6	IT7
21,300 - 23,990	15,5	-	14	6	IT7
24,000 - 29,990	16	-	16	6	IT7
30,000 - 39,990	17	-	20	8	IT6
40,000 - 50,700	19	-	24	8	IT6
50,710 - 65,000	25	-	24	8	IT6

Esempio tolleranza IT7:

HPR110Ø16.350H7ME1G-CU134

Diametro del foro d₁ = 16,350 H7**Esempio variante G:**

HPR110GØ16.350-3ME1G-CU134

Diametro utensile speciale d₁ = 16,350 -3 µm

Alesatore a testina intercambiabile HPR

Versione fissa con scanalatura obliqua sinistra, per foro passante
HPR110

Versione:

Diametro alesatore:

15,600 - 65,000 mm

Imbocco:

ME1G

Materiale da taglio:

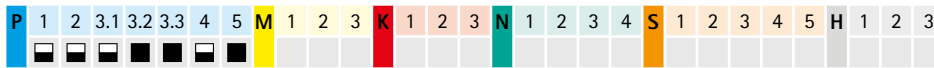
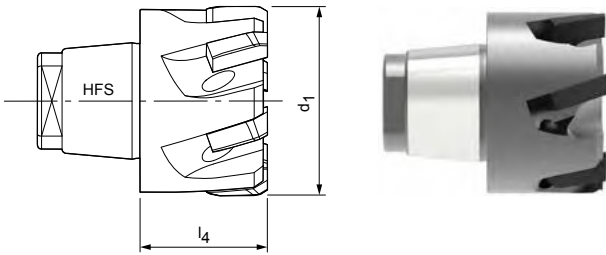
 HP421
 metallo duro rivestito
 in PVD

Caratteristiche configurabili

Diametro del foro tolleranza IT6/IT7:

- Diametro a libera scelta a passi da 0,001 mm
- Ordinabile in funzione del range di diametro a partire da tolleranze IT6/IT7
- > Ø30,000 IT6 | ≤ Ø30,000 IT7

Specifiche:

HPR110Ø[diametro][tolleranza]ME1G-HP421

Diametro del foro tolleranza < IT6/IT7:

- Tolleranze inferiori a IT6/IT7 ordinabili come diametro utensile speciale (per variante G vedere pagina 373)

Specifiche variante G:

HPR110GØ[diametro][tolleranza]ME1G-HP421

Dimensioni serie configurabile IT6/IT7

d1	l ₄	l ₅	Dimensione HFS	z	Tolleranza
15,600 - 18,590	14	-	10	6	IT7
18,600 - 21,290	14,5	-	12	6	IT7
21,300 - 23,990	15,5	-	14	6	IT7
24,000 - 29,990	16	-	16	6	IT7
30,000 - 39,990	17	-	20	8	IT6
40,000 - 50,700	19	-	24	8	IT6
50,710 - 65,000	25	-	24	8	IT6

Esempio tolleranza IT7:

HPR110Ø16.350H7ME1G-HP421

 Diametro del foro d₁ = 16,350 H7

Esempio variante G:

HPR110GØ16.350-5ME1G-HP421

 Diametro utensile speciale d₁ = 16,350 -5 µm

Misure in mm.

Supporto per testina intercambiabile HFS da pagina 460.

Per i parametri di lavorazione consigliati, vedere la fine del capitolo.

Alesatore a testina intercambiabile HPR

Versione fissa con scanalatura obliqua sinistra, per foro passante
HPR110

Versione:

Diametro alesatore:

15,600 - 65,000 mm

Imbocco:

MF1G

Materiale da taglio:

HP625

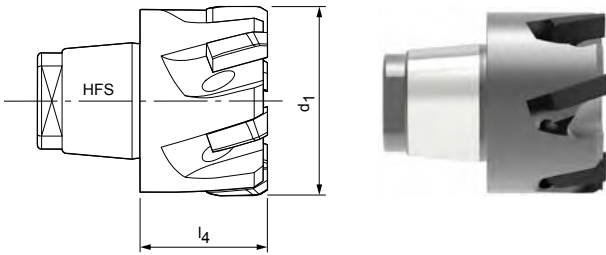
 metallo duro rivestito
in PVD

Caratteristiche configurabili

Diametro del foro tolleranza IT6/IT7:

- Diametro a libera scelta a passi da 0,001 mm
- Ordinabile in funzione del range di diametro a partire da tolleranze IT6/IT7
- > Ø30,000 IT6 | ≤ Ø30,000 IT7

Specifiche:

HPR110Ø[diametro][tolleranza]MF1G-HP625

Diametro del foro tolleranza < IT6/IT7:

- Tolleranze inferiori a IT6/IT7 ordinabili come diametro utensile speciale (per variante G vedere pagina 373)

Specifiche variante G:

HPR110GØ[diametro][tolleranza]MF1G-HP625

Dimensioni serie configurabile IT6/IT7

d1	l ₄	l ₅	Dimensione HFS	z	Tolleranza
15,600 - 18,590	14	-	10	6	IT7
18,600 - 21,290	14,5	-	12	6	IT7
21,300 - 23,990	15,5	-	14	6	IT7
24,000 - 29,990	16	-	16	6	IT7
30,000 - 39,990	17	-	20	8	IT6
40,000 - 50,700	19	-	24	8	IT6
50,710 - 65,000	25	-	24	8	IT6

Esempio tolleranza IT7:

HPR110Ø16.350H7MF1G-HP625

 Diametro del foro d₁ = 16,350 H7

Esempio variante G:

HPR110GØ16.350-7MF1G-HP625

 Diametro utensile speciale d₁ = 16,350 -5 µm

Misure in mm.

Supporto per testina intercambiabile HFS da pagina 460.

Per i parametri di lavorazione consigliati, vedere la fine del capitolo.

Alesatore a testina intercambiabile HPR

Versione fissa con scanalatura obliqua sinistra, per foro passante
HPR110

Versione:

Diametro alesatore:

15,600 - 65,000 mm

Imbocco:

MF1G

Materiale da taglio:

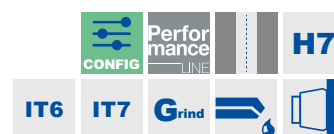
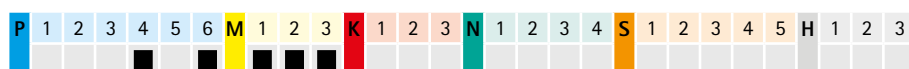
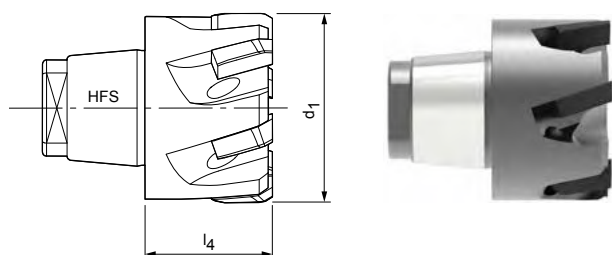
 HP421
 metallo duro rivestito
 in PVD

Serie selezionata per il magazzino in H7

d ₁ H7	Dimensione HFS	Dimensioni		Specifiche	Codice
		l ₄	z		
19,000	12	14,5	6	HPR110Ø19H7MF1G-HP421	30710291
20,000	12	14,5	6	HPR110Ø20H7MF1G-HP421	30401369
22,000	14	15,5	6	HPR110Ø22H7MF1G-HP421	30710293
23,000	14	15,5	6	HPR110Ø23H7MF1G-HP421	30710294
24,000	16	16	6	HPR110Ø24H7MF1G-HP421	30710295
25,000	16	16	6	HPR110Ø25H7MF1G-HP421	30318503
26,000	16	16	6	HPR110Ø26H7MF1G-HP421	30710296
27,000	16	16	6	HPR110Ø27H7MF1G-HP421	30710297
28,000	16	16	6	HPR110Ø28H7MF1G-HP421	30710298
30,000	20	17	8	HPR110Ø30H7MF1G-HP421	30576508
31,000	20	17	8	HPR110Ø31H7MF1G-HP421	30710300
32,000	20	17	8	HPR110Ø32H7MF1G-HP421	30671985
33,000	20	17	8	HPR110Ø33H7MF1G-HP421	30710301
34,000	20	17	8	HPR110Ø34H7MF1G-HP421	30710302
35,000	20	17	8	HPR110Ø35H7MF1G-HP421	30710303
39,000	20	17	8	HPR110Ø39H7MF1G-HP421	30710307
40,000	24	19	8	HPR110Ø40H7MF1G-HP421	30498368

Misure in mm.

Supporto per testina intercambiabile HFS da pagina 460.

Per i parametri di lavorazione consigliati, vedere la fine del capitolo.

HPR110 | Versione fissa, con scanalatura obliqua sinistra

Caratteristiche configurabili

**Diametro del foro tolleranza IT6/IT7:**

- Diametro a libera scelta a passi da 0,001 mm
- Ordinabile in funzione del range di diametro a partire da tolleranze IT6/IT7
- > Ø30,000 IT6 | ≤ Ø30,000 IT7

Specifiche:

HPR110Ø[diametro][tolleranza]MF1G-HP421

Diametro del foro tolleranza < IT6/IT7:

- Tolleranze inferiori a IT6/IT7 ordinabili come diametro utensile speciale (per variante G vedere pagina 373)

Specifiche variante G:

HPR110GØ[diametro][tolleranza]MF1G-HP421

Dimensioni serie configurabile IT6/IT7

d1	l ₄	l ₅	Dimensione HFS	z	Tolleranza
15,600 - 18,590	14	-	10	6	IT7
18,600 - 21,290	14,5	-	12	6	IT7
21,300 - 23,990	15,5	-	14	6	IT7
24,000 - 29,990	16	-	16	6	IT7
30,000 - 39,990	17	-	20	8	IT6
40,000 - 50,700	19	-	24	8	IT6
50,710 - 65,000	25	-	24	8	IT6

Esempio tolleranza IT7:

HPR110Ø16.350H7MF1G-HP421

Diametro del foro d₁ = 16,350 H7**Esempio variante G:**

HPR110GØ16.350-5MF1G-HP421

Diametro utensile speciale d₁ = 16,350 -5 µm

Alesatore a testina intercambiabile HPR

Versione fissa con scanalatura dritta, per foro cieco
HPR180

Versione:

Diametro alesatore:

7,000 - 21,290 mm

Imbocco:

ML2G

Materiale da taglio:

CU134

Cermet non rivestito

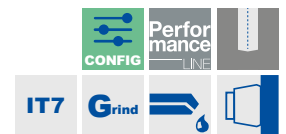
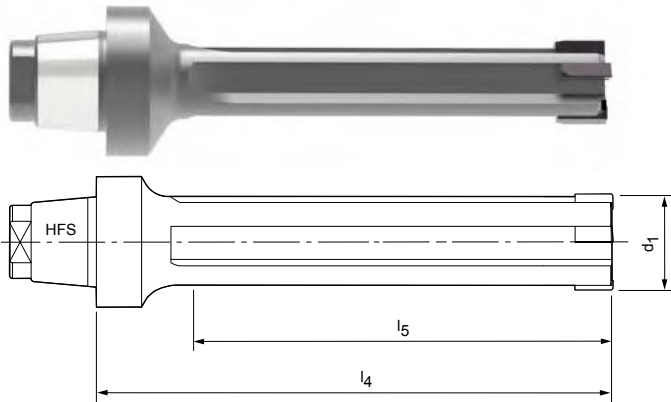

Caratteristiche configurabili

Diametro del foro tolleranza IT7:

- Diametro a libera scelta a passi da 0,001 mm
- Ordinabile a partire da tolleranza IT7

Specifiche:

HPR180Ø[diametro][tolleranza]ML2G-CU134

Diametro del foro tolleranza < IT7:

- Tolleranze inferiori a IT7 ordinabili come diametro utensile speciale (per variante G vedere pagina 373)

Specifiche variante G:

HPR180GØ[diametro][tolleranza]ML2G-CU134

Dimensioni serie configurabile IT7

d1	l ₄	l ₅	Dimensione HFS	z
7,000 - 14,590	60	40	12	4
14,600 - 21,290	60	40	12	6

Esempio tolleranza IT7:

HPR180Ø16.350H7ML2G-CU134

 Diametro del foro $d_1 = 16,350 \text{ H7}$
Esempio variante G:

HPR180GØ16.350-3ML2G-CU134

 Diametro utensile speciale $d_1 = 16,350 -3 \mu\text{m}$

Misure in mm.

Supporto per testina intercambiabile HFS da pagina 460.

Per i parametri di lavorazione consigliati, vedere la fine del capitolo.

Alesatore a testina intercambiabile HPR

Versione fissa con scanalatura dritta, per foro cieco
HPR180

Versione:

Diametro alesatore:

7,000 - 21,290 mm

Imbocco:

ML2G

Materiale da taglio:

HP421

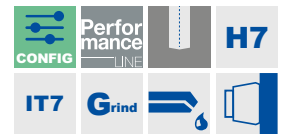
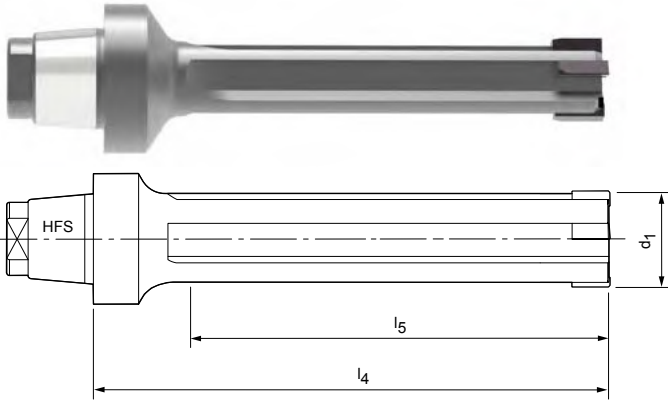
 metallo duro rivestito
in PVD

Serie selezionata per il magazzino in H7

d ₁ H7	Dimensione HFS	Dimensioni			Specifiche	Codice
		l ₄	l ₅	z		
10,000	12	60	40	4	HPR180Ø10H7ML2G-HP421	30710208
12,000	12	60	40	4	HPR180Ø12H7ML2G-HP421	30710210
14,000	12	60	40	4	HPR180Ø14H7ML2G-HP421	30710212
16,000	12	60	40	6	HPR180Ø16H7ML2G-HP421	30710214
18,000	12	60	40	6	HPR180Ø18H7ML2G-HP421	30710216
19,000	12	60	40	6	HPR180Ø19H7ML2G-HP421	30710217
20,000	12	60	40	6	HPR180Ø20H7ML2G-HP421	30710218

Caratteristiche configurabili

Diametro del foro tolleranza IT7:

- Diametro a libera scelta a passi da 0,001 mm
- Ordinabile a partire da tolleranza IT7

Specifiche:

HPR180Ø[diametro][tolleranza]ML2G-HP421

Diametro del foro tolleranza < IT7:

- Tolleranze inferiori a IT7 ordinabili come diametro utensile speciale (per variante G vedere pagina 373)

Specifiche variante G:

HPR180GØ[diametro][tolleranza]ML2G-HP421

Dimensioni serie configurabile IT7

d1	l ₄	l ₅	Dimensione HFS	z
7,000 - 14,590	60	40	12	4
14,600 - 21,290	60	40	12	6

Esempio tolleranza IT7:

HPR180Ø16.350H7ML2G-HP421

 Diametro del foro d₁ = 16,350 H7

Esempio variante G:

HPR180GØ16.350-5ML2G-HP421

 Diametro utensile speciale d₁ = 16,350 -5 µm

Misure in mm.

Supporto per testina intercambiabile HFS da pagina 460.

Per i parametri di lavorazione consigliati, vedere la fine del capitolo.

Alesatore a testina intercambiabile HPR

Versione fissa con scanalatura dritta, per foro cieco
HPR180

Versione:

Diametro alesatore:

7,000 - 21,290 mm

Imbocco:

M02G

Materiale da taglio:

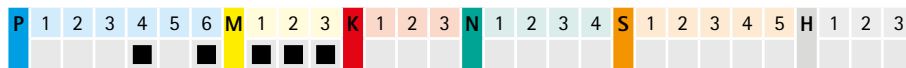
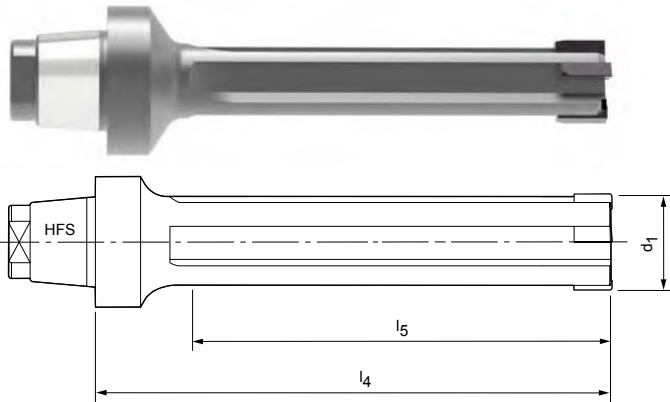
 HP421
 metallo duro rivestito
 in PVD

Caratteristiche configurabili

Diametro del foro tolleranza IT7:

- Diametro a libera scelta a passi da 0,001 mm
- Ordinabile a partire da tolleranza IT7

Specifiche:

HPR180Ø[diametro][tolleranza]M02G-HP421

Diametro del foro tolleranza < IT7:

- Tolleranze inferiori a IT7 ordinabili come diametro utensile speciale (per variante G vedere pagina 373)

Specifiche variante G:

HPR180GØ[diametro][tolleranza]M02G-HP421

Dimensioni serie configurabile IT7

d1	l ₄	l ₅	Dimensione HFS	z
7,000 - 14,590	60	40	12	4
14,600 - 21,290	60	40	12	6

Esempio tolleranza IT7:

HPR180Ø16.350H7M02G-HP421

 Diametro del foro $d_1 = 16,350 \text{ H7}$
Esempio variante G:

HPR180GØ16.350-5M02G-HP421

 Diametro utensile speciale $d_1 = 16,350 -5 \mu\text{m}$

Misure in mm.

Supporto per testina intercambiabile HFS da pagina 460.

Per i parametri di lavorazione consigliati, vedere la fine del capitolo.

Alesatore a testina intercambiabile HPR

Versione fissa con scanalatura dritta, per foro cieco
HPR180

Versione:

Diametro alesatore:

7,000 - 21,290 mm

Imbocco:

MC1G

Materiale da taglio:

CP134

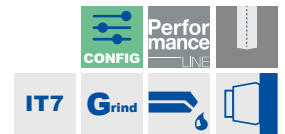
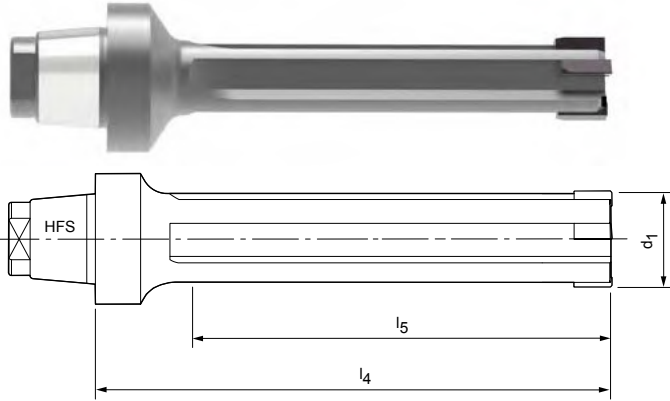
 Cermet rivestito in
PVD

Caratteristiche configurabili

Diametro del foro tolleranza IT7:

- Diametro a libera scelta a passi da 0,001 mm
- Ordinabile a partire da tolleranza IT7

Specifiche:

HPR180Ø[diametro][tolleranza]MC1G-CP134

Diametro del foro tolleranza < IT7:

- Tolleranze inferiori a IT7 ordinabili come diametro utensile speciale (per variante G vedere pagina 373)

Specifiche variante G:

HPR180GØ[diametro][tolleranza]MC1G-CP134

Dimensioni serie configurabile IT7

d1	l ₄	l ₅	Dimensione HFS	z
7,000 - 14,590	60	40	12	4
14,600 - 21,290	60	40	12	6

Esempio tolleranza IT7:

HPR180Ø16.350H7MC1G-CP134

 Diametro del foro $d_1 = 16,350 \text{ H7}$
Esempio variante G:

HPR180GØ16.350-5MC1G-CP134

 Diametro utensile speciale $d_1 = 16,350 -5 \mu\text{m}$

Misure in mm.

 * per superfici $R_a > 2 \mu\text{m}$

Supporto per testina intercambiabile HFS da pagina 460.

Per i parametri di lavorazione consigliati, vedere la fine del capitolo.

Alesatore a testina intercambiabile HPR

Versione fissa con scanalatura dritta, per foro cieco
HPR180

Versione:

Diametro alesatore:

7,000 - 21,290 mm

Imbocco:

MC1G

Materiale da taglio:

Metallo duro rivestito

in CVD

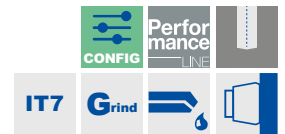
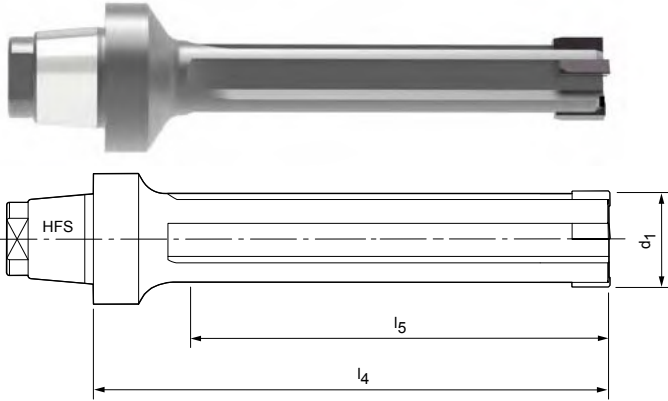

Caratteristiche configurabili

Diametro del foro tolleranza IT7:

- Diametro a libera scelta a passi da 0,001 mm
- Ordinabile a partire da tolleranza IT7

Specifiche:

HPR180Ø[diametro][tolleranza]MC1G-HC419

Diametro del foro tolleranza < IT7:

- Tolleranze inferiori a IT7 ordinabili come diametro utensile speciale (per variante G vedere pagina 373)

Specifiche variante G:

HPR180GØ[diametro][tolleranza]MC1G-HC419

Dimensioni serie configurabile IT7

d1	l ₄	l ₅	Dimensione HFS	z
7,000 - 14,590	60	40	12	4
14,600 - 21,290	60	40	12	6

Esempio tolleranza IT7:

HPR180Ø16.350H7MC1G-HC419

 Diametro del foro $d_1 = 16,350 \text{ H7}$
Esempio variante G:

HPR180GØ16.350-7MC1G-HC419

 Diametro utensile speciale $d_1 = 16,350 -7 \mu\text{m}$

Misure in mm.

 * per superfici $R_a < 2 \mu\text{m}$

Supporto per testina intercambiabile HFS da pagina 460.

Per i parametri di lavorazione consigliati, vedere la fine del capitolo.

Alesatore a testina intercambiabile HPR

Versione fissa con scanalatura dritta, per foro cieco
HPR180

Versione:

Diametro alesatore:

7,000 - 21,290 mm

Imbocco:

MC1G

Materiale da taglio:

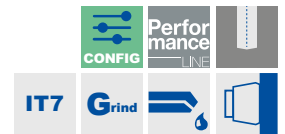
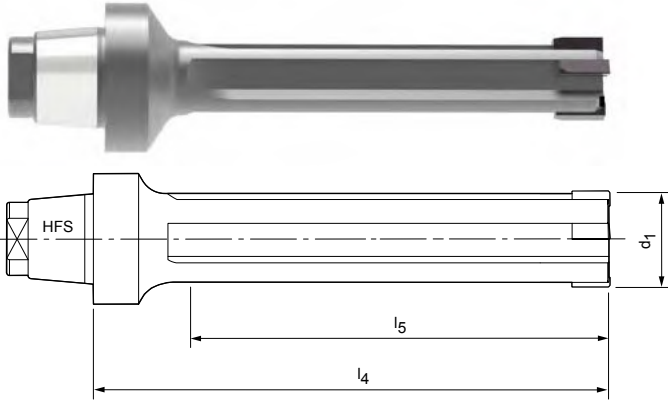
 HP421
metallo duro rivestito
in PVD

Caratteristiche configurabili

Diametro del foro tolleranza IT7:

- Diametro a libera scelta a passi da 0,001 mm
- Ordinabile a partire da tolleranza IT7

Specifiche:

HPR180Ø[diametro][tolleranza]MC1G-HP421

Diametro del foro tolleranza < IT7:

- Tolleranze inferiori a IT7 ordinabili come diametro utensile speciale (per variante G vedere pagina 373)

Specifiche variante G:

HPR180GØ[diametro][tolleranza]MC1G-HP421

Dimensioni serie configurabile IT7

d1	l ₄	l ₅	Dimensione HFS	z
7,000 - 14,590	60	40	12	4
14,600 - 21,290	60	40	12	6

Esempio tolleranza IT7:

HPR180Ø16.350H7MC1G-HP421

 Diametro del foro d₁ = 16,350 H7

Esempio variante G:

HPR180GØ16.350-5MC1G-HP421

 Diametro utensile speciale d₁ = 16,350 -5 µm

Misure in mm.

Supporto per testina intercambiabile HFS da pagina 460.

Per i parametri di lavorazione consigliati, vedere la fine del capitolo.

Alesatore a testina intercambiabile HPR

Versione fissa con scanalatura dritta, per foro cieco
HPR180

Versione:

Diametro alesatore:

7,000 - 21,290 mm

Imbocco:

MC1G

Materiale da taglio:

metallo duro rivestito

in PVD

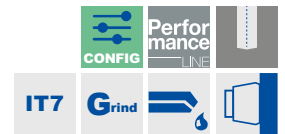
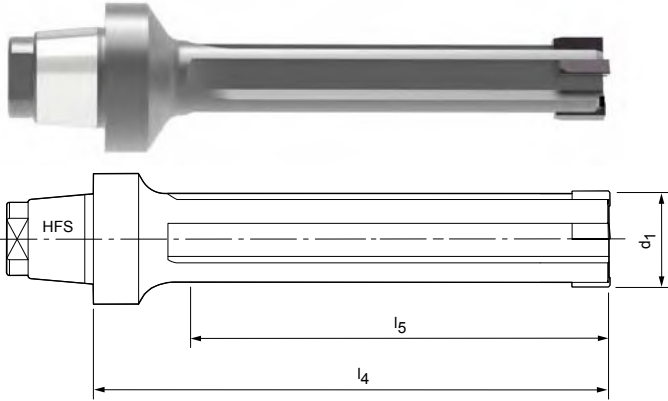
Caratteristiche configurabili

Diametro del foro tolleranza IT7:

- Diametro a libera scelta a passi da 0,001 mm
- Ordinabile a partire da tolleranza IT7

Specifiche:

HPR180Ø[diametro][tolleranza]MC1G-HP423

Diametro del foro tolleranza < IT7:

- Tolleranze inferiori a IT7 ordinabili come diametro utensile speciale (per variante G vedere pagina 373)

Specifiche variante G:

HPR180GØ[diametro][tolleranza]MC1G-HP423

Dimensioni serie configurabile IT7

d1	l ₄	l ₅	Dimensione HFS	z
7,000 - 14,590	60	40	12	4
14,600 - 21,290	60	40	12	6

Esempio tolleranza IT7:

HPR180Ø16.350H7MC1G-HP423

 Diametro del foro d₁ = 16,350 H7

Esempio variante G:

HPR180GØ16.350-8MC1G-HP423

 Diametro utensile speciale d₁ = 16,350 -7 µm

Misure in mm.

Supporto per testina intercambiabile HFS da pagina 460.

Per i parametri di lavorazione consigliati, vedere la fine del capitolo.

Alesatore a testina intercambiabile HPR

Versione fissa con scanalatura dritta, per foro cieco
HPR180

Versione:

Diametro alesatore:

7,000 - 21,290 mm

Imbocco:

MA0A

Materiale da taglio:

PU620

Con riporto in PCD

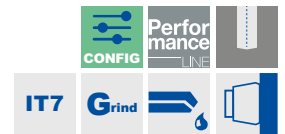
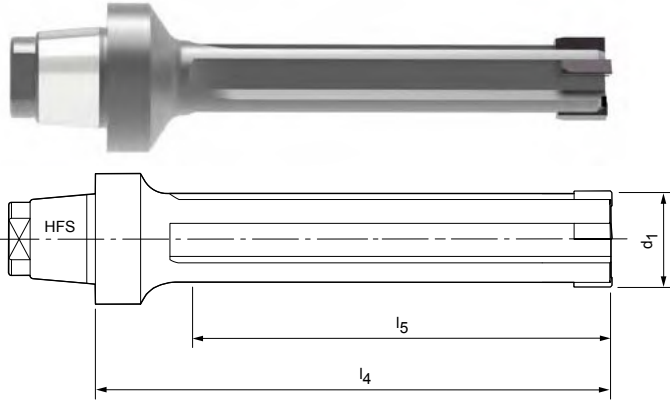

Caratteristiche configurabili

Diametro del foro tolleranza IT7:

- Diametro a libera scelta a passi da 0,001 mm
- Ordinabile a partire da tolleranza IT7

Specifiche:

HPR180Ø[diametro][tolleranza]MA0A-PU620

Diametro del foro tolleranza < IT7:

- Tolleranze inferiori a IT7 ordinabili come diametro utensile speciale (per variante G vedere pagina 373)

Specifiche variante G:

HPR180GØ[diametro][tolleranza]MA0A-PU620

Dimensioni serie configurabile IT7

d1	l ₄	l ₅	Dimensione HFS	z
7,000 - 14,590	60	40	12	4
14,600 - 21,290	60	40	12	6

Esempio tolleranza IT7:

HPR180Ø16.350H7MA0A-PU620

 Diametro del foro $d_1 = 16,350 \text{ H7}$
Esempio variante G:

HPR180GØ16.350-3MA0A-PU620

 Diametro utensile speciale $d_1 = 16,350 -3 \mu\text{m}$

Misure in mm.

Supporto per testina intercambiabile HFS da pagina 460.

Per i parametri di lavorazione consigliati, vedere la fine del capitolo.

Alesatore a testina intercambiabile HPR

Versione fissa con scanalatura dritta, per foro cieco
HPR180

Versione:

Diametro alesatore:

7,000 - 21,290 mm

Imbocco:

M02G

Materiale da taglio:

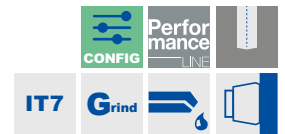
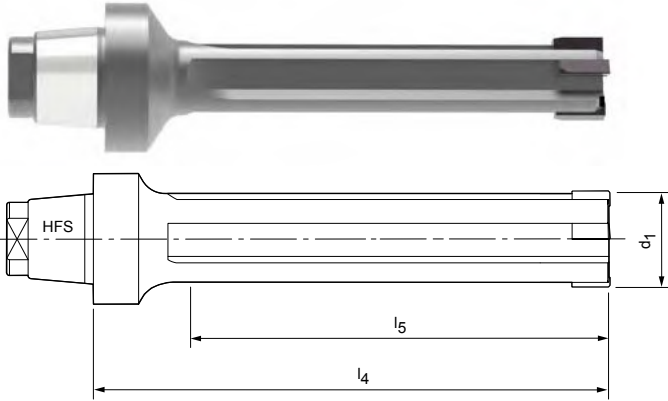
 metallo duro rivestito
in PVD

Caratteristiche configurabili

Diametro del foro tolleranza IT7:

- Diametro a libera scelta a passi da 0,001 mm
- Ordinabile a partire da tolleranza IT7

Specifiche:

HPR180Ø[diametro][tolleranza]M02G-HP625

Diametro del foro tolleranza < IT7:

- Tolleranze inferiori a IT7 ordinabili come diametro utensile speciale (per variante G vedere pagina 373)

Specifiche variante G:

HPR180GØ[diametro][tolleranza]M02G-HP625

Dimensioni serie configurabile IT7

d1	l ₄	l ₅	Dimensione HFS	z
7,000 - 14,590	60	40	12	4
14,600 - 21,290	60	40	12	6

Esempio tolleranza IT7:

HPR180Ø16.350H7M02G-HP625

 Diametro del foro d₁ = 16,350 H7

Esempio variante G:

HPR180GØ16.350-7M02G-HP625

 Diametro utensile speciale d₁ = 16,350 -5 µm

Misure in mm.

Supporto per testina intercambiabile HFS da pagina 460.

Per i parametri di lavorazione consigliati, vedere la fine del capitolo.

Alesatore a testina intercambiabile HPR

Versione fissa con scanalatura dritta, per foro cieco
HPR150

Versione:

Diametro alesatore:

16,600 - 65,000 mm

Imbocco:

ML2G

Materiale da taglio:

CU134

Cermet non rivestito

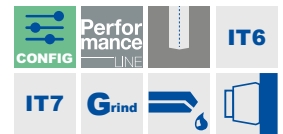
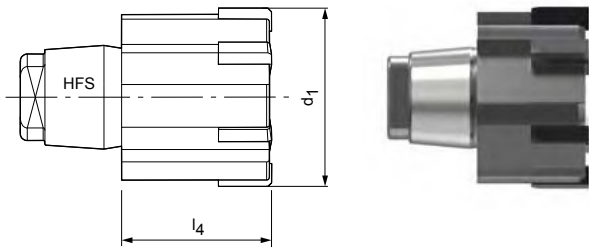

Caratteristiche configurabili



Diametro del foro tolleranza IT6/IT7:

- Diametro a libera scelta a passi da 0,001 mm
- Ordinabile in funzione del range di diametro a partire da tolleranze IT6/IT7
- > Ø30,000 IT6 | ≤ Ø30,000 IT7

Specifiche:

HPR150Ø[diametro][tolleranza]ML2G-CU134

Diametro del foro tolleranza < IT6/IT7:

- Tolleranze inferiori a IT6/IT7 ordinabili come diametro utensile speciale (per variante G vedere pagina 373)

Specifiche variante G:

HPR150GØ[diametro][tolleranza]ML2G-CU134

Dimensioni serie configurabile IT6/IT7

d1	l ₄	l ₅	Dimensione HFS	z	Tolleranza
16,600 - 21,290	14	-	10	6	IT7
21,300 - 24,990	15,5	-	12	6	IT7
25,000 - 28,990	15,5	-	14	6	IT7
29,000 - 29,990	17	-	16	6	IT7
30,000 - 36,990	17	-	16	6	IT6
37,000 - 44,990	17	-	20	8	IT6
45,000 - 50,700	19	-	24	8	IT6
50,710 - 65,000	25	-	24	8	IT6

Esempio tolleranza IT6:

HPR150Ø37.350H6ML2G-CU134

 Diametro del foro d₁ = 37,350 H6

Esempio variante G:

HPR150GØ37.350-3ML2G-CU134

 Diametro utensile speciale d₁ = 37,350 -3 μm

Misure in mm.

Supporto per testina intercambiabile HFS da pagina 460.

Per i parametri di lavorazione consigliati, vedere la fine del capitolo.

Alesatore a testina intercambiabile HPR

Versione fissa con scanalatura dritta, per foro cieco
HPR150

Versione:

Diametro alesatore:

16,600 - 65,000 mm

Imbocco:

ML2G

Materiale da taglio:

HP421

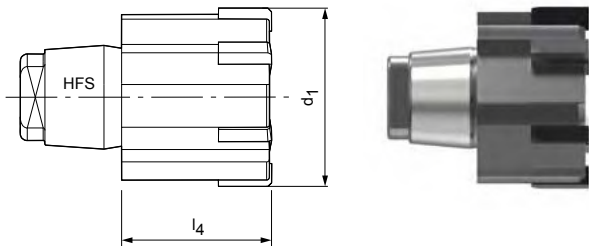
 metallo duro rivestito
in PVD

Serie selezionata per il magazzino in H7

d ₁ H7	Dimensione HFS	Dimensioni		Specifiche	Codice
		l ₄	z		
22,000	12	15,5	6	HPR150Ø22H7ML2G-HP421	30098915
24,000	12	15,5	6	HPR150Ø24H7ML2G-HP421	30329443
26,000	12	15,5	6	HPR150Ø26H7ML2G-HP421	30044823
28,000	12	15,5	6	HPR150Ø28H7ML2G-HP421	30710391
30,000	16	17	6	HPR150Ø30H7ML2G-HP421	30710393
32,000	16	17	6	HPR150Ø32H7ML2G-HP421	30462441
40,000	16	17	8	HPR150Ø40H7ML2G-HP421	30586834

Caratteristiche configurabili

Diametro del foro tolleranza IT6/IT7:

- Diametro a libera scelta a passi da 0,001 mm
- Ordinabile in funzione del range di diametro a partire da tolleranze IT6/IT7
- > Ø30,000 IT6 | ≤ Ø30,000 IT7

Specifiche:

HPR150Ø[diametro][tolleranza]ML2G-HP421

Diametro del foro tolleranza < IT6/IT7:

- Tolleranze inferiori a IT6/IT7 ordinabili come diametro utensile speciale (per variante G vedere pagina 373)

Specifiche variante G:

HPR150GØ[diametro][tolleranza]ML2G-HP421

Dimensioni serie configurabile IT6/IT7

d ₁	l ₄	l ₅	Dimensione HFS	z	Tolleranza
16,600 - 21,290	14	-	10	6	IT7
21,300 - 24,990	15,5	-	12	6	IT7
25,000 - 28,990	15,5	-	14	6	IT7
29,000 - 29,990	17	-	16	6	IT7
30,000 - 36,990	17	-	16	6	IT6
37,000 - 44,990	17	-	20	8	IT6
45,000 - 50,700	19	-	24	8	IT6
50,710 - 65,000	25	-	24	8	IT6

Esempio tolleranza IT6:

HPR150Ø37.350H6ML2G-HP421

 Diametro del foro d₁ = 37,350 H6

Esempio variante G:

HPR150GØ37.350-5ML2G-HP421

 Diametro utensile speciale d₁ = 37,350 -5 µm

Misure in mm.

Supporto per testina intercambiabile HFS da pagina 460.

Per i parametri di lavorazione consigliati, vedere la fine del capitolo.

Alesatore a testina intercambiabile HPR

Versione fissa con scanalatura dritta, per foro cieco
HPR150

Versione:

Diametro alesatore:

16,600 - 65,000 mm

Imbocco:

M02G

Materiale da taglio:

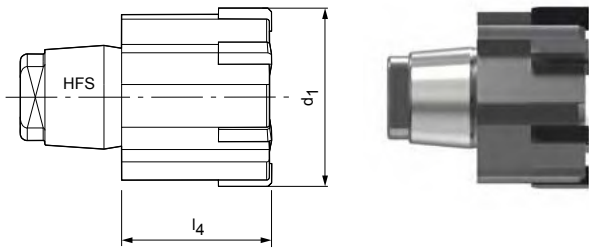
 HP421
 metallo duro rivestito
 in PVD

Serie selezionata per il magazzino in H7

d ₁ H7	Dimensione HFS	Dimensioni		Specifiche	Codice
		l ₄	z		
20,000	10	14	6	HPR150Ø20H7M02G-HP421	30975790
26,000	14	15,5	6	HPR150Ø26H7M02G-HP421	30975773
28,000	14	15,5	6	HPR150Ø28H7M02G-HP421	30843363
30,000	16	17	6	HPR150Ø30H7M02G-HP421	30975775
32,000	16	17	6	HPR150Ø32H7M02G-HP421	30975776
35,000	16	17	6	HPR150Ø35H7M02G-HP421	30976284
40,000	20	17	8	HPR150Ø40H7M02G-HP421	30898813

Caratteristiche configurabili

Diametro del foro tolleranza IT6/IT7:

- Diametro a libera scelta a passi da 0,001 mm
- Ordinabile in funzione del range di diametro a partire da tolleranze IT6/IT7
- > Ø30,000 IT6 | ≤ Ø30,000 IT7

Specifiche:

HPR150Ø[diametro][tolleranza]M02G-HP421

Diametro del foro tolleranza < IT6/IT7:

- Tolleranze inferiori a IT6/IT7 ordinabili come diametro utensile speciale (per variante G vedere pagina 373)

Specifiche variante G:

HPR150GØ[diametro][tolleranza]M02G-HP421

Dimensioni serie configurabile IT6/IT7

d ₁	l ₄	l ₅	Dimensione HFS	z	Tolleranza
16,600 - 21,290	14	-	10	6	IT7
21,300 - 24,990	15,5	-	12	6	IT7
25,000 - 28,990	15,5	-	14	6	IT7
29,000 - 29,990	17	-	16	6	IT7
30,000 - 36,990	17	-	16	6	IT6
37,000 - 44,990	17	-	20	8	IT6
45,000 - 50,700	19	-	24	8	IT6
50,710 - 65,000	25	-	24	8	IT6

Esempio tolleranza IT6:

HPR150Ø37.350H6M02G-HP421

 Diametro del foro d₁ = 37,350 H6

Esempio variante G:

HPR150GØ37.350-5M02G-HP421

 Diametro utensile speciale d₁ = 37,350 -5 µm

Misure in mm.

Supporto per testina intercambiabile HFS da pagina 460.

Per i parametri di lavorazione consigliati, vedere la fine del capitolo.

Alesatore a testina intercambiabile HPR

Versione fissa con scanalatura dritta, per foro cieco
HPR150

Versione:

Diametro alesatore:

16,600 - 65,000 mm

Imbocco:

MC1G

Materiale da taglio:

CP134

Cermet rivestito in

PVD

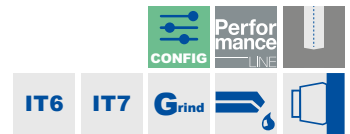
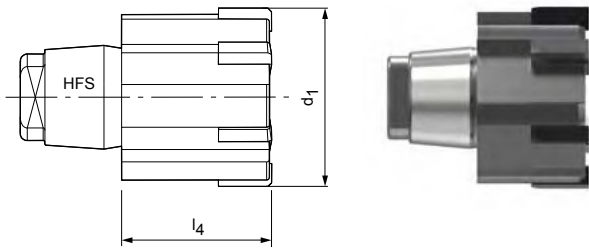

Caratteristiche configurabili

Diametro del foro tolleranza IT6/IT7:

- Diametro a libera scelta a passi da 0,001 mm
- Ordinabile in funzione del range di diametro a partire da tolleranze IT6/IT7
- > Ø30,000 IT6 | ≤ Ø30,000 IT7

Specifiche:

HPR150Ø[diametro][tolleranza]MC1G-CP134

Diametro del foro tolleranza < IT6/IT7:

- Tolleranze inferiori a IT6/IT7 ordinabili come diametro utensile speciale (per variante G vedere pagina 373)

Specifiche variante G:

HPR150GØ[diametro][tolleranza]MC1G-CP134

Dimensioni serie configurabile IT6/IT7

d1	l ₄	l ₅	Dimensione HFS	z	Tolleranza
16,600 - 21,290	14	-	10	6	IT7
21,300 - 24,990	15,5	-	12	6	IT7
25,000 - 28,990	15,5	-	14	6	IT7
29,000 - 29,990	17	-	16	6	IT7
30,000 - 36,990	17	-	16	6	IT6
37,000 - 44,990	17	-	20	8	IT6
45,000 - 50,700	19	-	24	8	IT6
50,710 - 65,000	25	-	24	8	IT6

Esempio tolleranza IT6:

HPR150Ø37.350H6MC1G-CP134

 Diametro del foro d₁ = 37,350 H6

Esempio variante G:

HPR150GØ37.350-5MC1G-CP134

 Diametro utensile speciale d₁ = 37,350 -5 µm

Misure in mm.

 * per superfici R_a < 2 µm

Supporto per testina intercambiabile HFS da pagina 460.

Per i parametri di lavorazione consigliati, vedere la fine del capitolo.

Alesatore a testina intercambiabile HPR

Versione fissa con scanalatura dritta, per foro cieco
HPR150

Versione:

Diametro alesatore:

16,600 - 65,000 mm

Imbocco:

MC1G

Materiale da taglio:

HC419

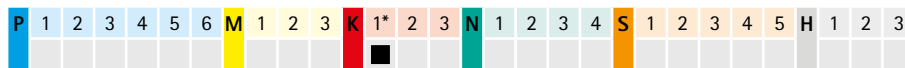
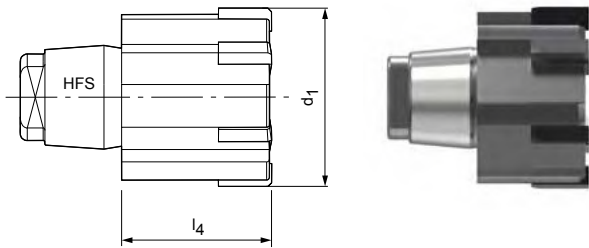
 Metallo duro rivestito
in CVD

Caratteristiche configurabili



Diametro del foro tolleranza IT6/IT7:

- Diametro a libera scelta a passi da 0,001 mm
- Ordinabile in funzione del range di diametro a partire da tolleranze IT6/IT7
- > Ø30,000 IT6 | ≤ Ø30,000 IT7

Specifiche:

HPR150Ø[diametro][tolleranza]MC1G-HC419

Diametro del foro tolleranza < IT6/IT7:

- Tolleranze inferiori a IT6/IT7 ordinabili come diametro utensile speciale (per variante G vedere pagina 373)

Specifiche variante G:

HPR150GØ[diametro][tolleranza]MC1G-HC419

Dimensioni serie configurabile IT6/IT7

d1	l ₄	l ₅	Dimensione HFS	z	Tolleranza
16,600 - 21,290	14	-	10	6	IT7
21,300 - 24,990	15,5	-	12	6	IT7
25,000 - 28,990	15,5	-	14	6	IT7
29,000 - 29,990	17	-	16	6	IT7
30,000 - 36,990	17	-	16	6	IT6
37,000 - 44,990	17	-	20	8	IT6
45,000 - 50,700	19	-	24	8	IT6
50,710 - 65,000	25	-	24	8	IT6

Esempio tolleranza IT6:

HPR150Ø37.350H6MC1G-HC419

 Diametro del foro d₁ = 37,350 H6

Esempio variante G:

HPR150GØ37.350-7MC1G-HC419

 Diametro utensile speciale d₁ = 37,350 -7 µm

Misure in mm.

 * per superfici R_a > 2 µm

Supporto per testina intercambiabile HFS da pagina 460.

Per i parametri di lavorazione consigliati, vedere la fine del capitolo.

Alesatore a testina intercambiabile HPR

Versione fissa con scanalatura dritta, per foro cieco
HPR150

Versione:

Diametro alesatore:

16,600 - 65,000 mm

Imbocco:

MC1G

Materiale da taglio:

HP421

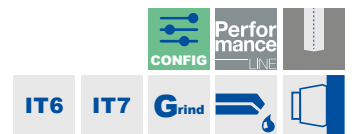
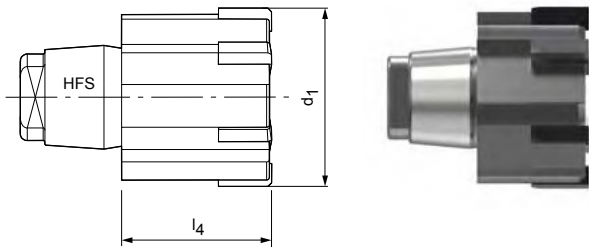
 metallo duro rivestito
in PVD

Caratteristiche configurabili



Diametro del foro tolleranza IT6/IT7:

- Diametro a libera scelta a passi da 0,001 mm
- Ordinabile in funzione del range di diametro a partire da tolleranze IT6/IT7
- > Ø30,000 IT6 | ≤ Ø30,000 IT7

Specifiche:

HPR150Ø[diametro][tolleranza]MC1G-HP421

Diametro del foro tolleranza < IT6/IT7:

- Tolleranze inferiori a IT6/IT7 ordinabili come diametro utensile speciale (per variante G vedere pagina 373)

Specifiche variante G:

HPR150GØ[diametro][tolleranza]MC1G-HP421

Dimensioni serie configurabile IT6/IT7

d1	l ₄	l ₅	Dimensione HFS	z	Tolleranza
16,600 - 21,290	14	-	10	6	IT7
21,300 - 24,990	15,5	-	12	6	IT7
25,000 - 28,990	15,5	-	14	6	IT7
29,000 - 29,990	17	-	16	6	IT7
30,000 - 36,990	17	-	16	6	IT6
37,000 - 44,990	17	-	20	8	IT6
45,000 - 50,700	19	-	24	8	IT6
50,710 - 65,000	25	-	24	8	IT6

Esempio tolleranza IT6:

HPR150Ø37.350H6MC1G-HP421

 Diametro del foro d₁ = 37,350 H6

Esempio variante G:

HPR150GØ37.350-5MC1G-HP421

 Diametro utensile speciale d₁ = 37,350 -5 µm

Misure in mm.

Supporto per testina intercambiabile HFS da pagina 460.

Per i parametri di lavorazione consigliati, vedere la fine del capitolo.

Alesatore a testina intercambiabile HPR

Versione fissa con scanalatura dritta, per foro cieco
HPR150

Versione:

Diametro alesatore:

16,600 - 65,000 mm

Imbocco:

MC1G

Materiale da taglio:

HP423

metallo duro rivestito
in PVD

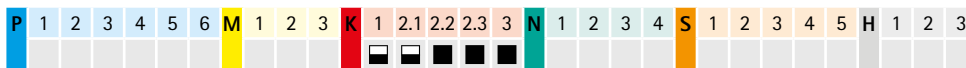
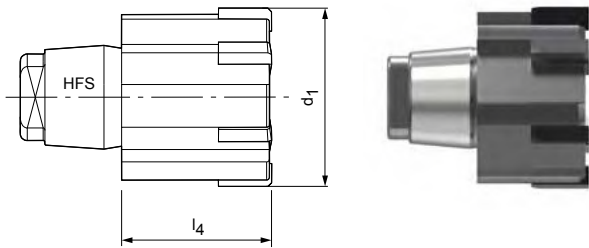

Caratteristiche configurabili



Diametro del foro tolleranza IT6/IT7:

- Diametro a libera scelta a passi da 0,001 mm
- Ordinabile in funzione del range di diametro a partire da tolleranze IT6/IT7
- > Ø30,000 IT6 | ≤ Ø30,000 IT7

Specifiche:

HPR150Ø[diametro][tolleranza]MC1G-HP423

Diametro del foro tolleranza < IT6/IT7:

- Tolleranze inferiori a IT6/IT7 ordinabili come diametro utensile speciale (per variante G vedere pagina 373)

Specifiche variante G:

HPR150GØ[diametro][tolleranza]MC1G-HP423

Dimensioni serie configurabile IT6/IT7

d1	l ₄	l ₅	Dimensione HFS	z	Tolleranza
16,600 - 21,290	14	-	10	6	IT7
21,300 - 24,990	15,5	-	12	6	IT7
25,000 - 28,990	15,5	-	14	6	IT7
29,000 - 29,990	17	-	16	6	IT7
30,000 - 36,990	17	-	16	6	IT6
37,000 - 44,990	17	-	20	8	IT6
45,000 - 50,700	19	-	24	8	IT6
50,710 - 65,000	25	-	24	8	IT6

Esempio tolleranza IT6:

HPR150Ø37.350H6MC1G-HP423

Diametro del foro d₁ = 37,350 H6

Esempio variante G:

HPR150GØ37.350-8MC1G-HP423

Diametro utensile speciale d₁ = 37,350 -7 µm

Misure in mm.

Supporto per testina intercambiabile HFS da pagina 460.

Per i parametri di lavorazione consigliati, vedere la fine del capitolo.

Alesatore a testina intercambiabile HPR

Versione fissa con scanalatura dritta, per foro cieco
HPR150

Versione:

Diametro alesatore:

16,600 - 65,000 mm

Imbocco:

MA0A

Materiale da taglio:

PU620

Con riporto in PCD

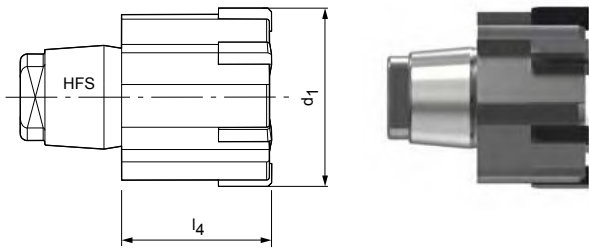

Caratteristiche configurabili

Diametro del foro tolleranza IT6/IT7:

- Diametro a libera scelta a passi da 0,001 mm
- Ordinabile in funzione del range di diametro a partire da tolleranze IT6/IT7
- > Ø30,000 IT6 | ≤ Ø30,000 IT7

Specifiche:

HPR150Ø[diametro][tolleranza]MA0A-PU620

Diametro del foro tolleranza < IT6/IT7:

- Tolleranze inferiori a IT6/IT7 ordinabili come diametro utensile speciale (per variante G vedere pagina 373)

Specifiche variante G:

HPR150GØ[diametro][tolleranza]MA0A-PU620

Dimensioni serie configurabile IT6/IT7

d1	l ₄	l ₅	Dimensione HFS	z	Tolleranza
16,600 - 21,290	14	-	10	6	IT7
21,300 - 24,990	15,5	-	12	6	IT7
25,000 - 28,990	15,5	-	14	6	IT7
29,000 - 29,990	17	-	16	6	IT7
30,000 - 36,990	17	-	16	6	IT6
37,000 - 44,990	17	-	20	8	IT6
45,000 - 50,700	19	-	24	8	IT6
50,710 - 65,000	25	-	24	8	IT6

Esempio tolleranza IT6:

HPR150Ø37.350H6MA0A-PU620

 Diametro del foro d₁ = 37,350 H6

Esempio variante G:

HPR150GØ37.350-3MA0A-PU620

 Diametro utensile speciale d₁ = 37,350 -3 μm

Misure in mm.

Supporto per testina intercambiabile HFS da pagina 460.

Per i parametri di lavorazione consigliati, vedere la fine del capitolo.

Alesatore a testina intercambiabile HPR

Versione fissa con scanalatura dritta, per foro cieco
HPR150

Versione:

Diametro alesatore:

16,600 - 65,000 mm

Imbocco:

M02G

Materiale da taglio:

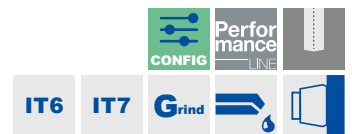
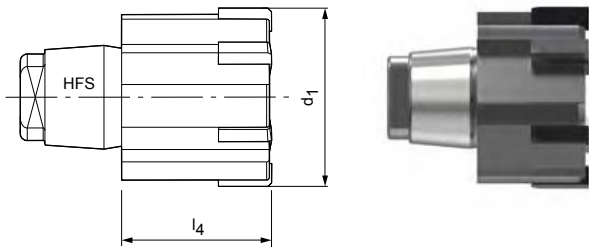
 HP625
 metallo duro rivestito
 in PVD

Caratteristiche configurabili

Diametro del foro tolleranza IT6/IT7:

- Diametro a libera scelta a passi da 0,001 mm
- Ordinabile in funzione del range di diametro a partire da tolleranze IT6/IT7
- > Ø30,000 IT6 | ≤ Ø30,000 IT7

Specifiche:

HPR150Ø[diametro][tolleranza]M02G-HP625

Diametro del foro tolleranza < IT6/IT7:

- Tolleranze inferiori a IT6/IT7 ordinabili come diametro utensile speciale (per variante G vedere pagina 373)

Specifiche variante G:

HPR150GØ[diametro][tolleranza]M02G-HP625

Dimensioni serie configurabile IT6/IT7

d1	l ₄	l ₅	Dimensione HFS	z	Tolleranza
16,600 - 21,290	14	-	10	6	IT7
21,300 - 24,990	15,5	-	12	6	IT7
25,000 - 28,990	15,5	-	14	6	IT7
29,000 - 29,990	17	-	16	6	IT7
30,000 - 36,990	17	-	16	6	IT6
37,000 - 44,990	17	-	20	8	IT6
45,000 - 50,700	19	-	24	8	IT6
50,710 - 65,000	25	-	24	8	IT6

Esempio tolleranza IT6:

HPR150Ø37.350H6M02G-HP625

 Diametro del foro d₁ = 37,350 H6

Esempio variante G:

HPR150GØ37.350-7M02G-HP625

 Diametro utensile speciale d₁ = 37,350 -5 µm

Misure in mm.

Supporto per testina intercambiabile HFS da pagina 460.

Per i parametri di lavorazione consigliati, vedere la fine del capitolo.

Alesatore a testina intercambiabile HPR

Versione con regolazione fine, scanalatura dritta, per foro passante
HPR230

Versione:

Diametro alesatore:

7,000 - 18,590 mm

Imbocco:

MC1G

Materiale da taglio:

CP134

Cermet rivestito in

PVD

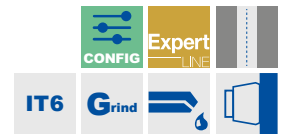
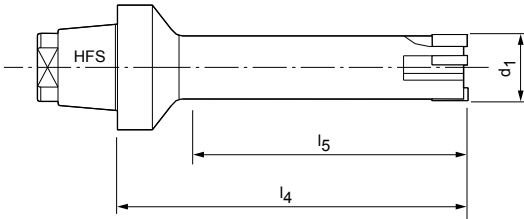
Caratteristiche configurabili

Diametro del foro tolleranza IT6:

- Diametro a libera scelta a passi da 0,001 mm
- Ordinabile in tolleranza IT6

Specifiche:

HPR230Ø[diametro][tolleranza]MC1G-CP134

Diametro del foro tolleranza < IT6:

- Tolleranze inferiori a IT6 ordinabili come diametro utensile speciale (per variante G vedere pagina 373)

Specifiche variante G:

HPR230GØ[diametro][tolleranza]MC1G-CP134

Dimensioni serie configurabile IT6

d ₁	l ₄	l ₅	Dimensione HFS	z
7,000 - 9,590	60	45	12	4
9,600 - 18,590	60	45	12	6

Esempio tolleranza IT6:

HPR230Ø10.350H6MC1G-CP134

 Diametro del foro d₁ = 10,350 H6

Esempio variante G:

HPR230GØ10.350+1-1MC1G-CP134

 Diametro utensile speciale d₁ = 10,350 +1 µm -1 µm

Misure in mm.

 * per superfici R_a < 2 µm

Supporto per testina intercambiabile HFS da pagina 460.

Per i parametri di lavorazione consigliati, vedere la fine del capitolo.

Alesatore a testina intercambiabile HPR

Versione con regolazione fine, scanalatura dritta, per foro passante
HPR230

Versione:

Diametro alesatore:

7,000 - 18,590 mm

Imbocco:

MC1G

Materiale da taglio:

HP421

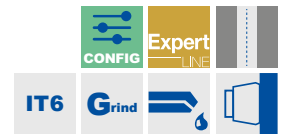
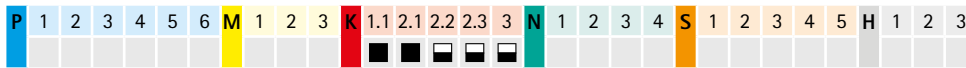
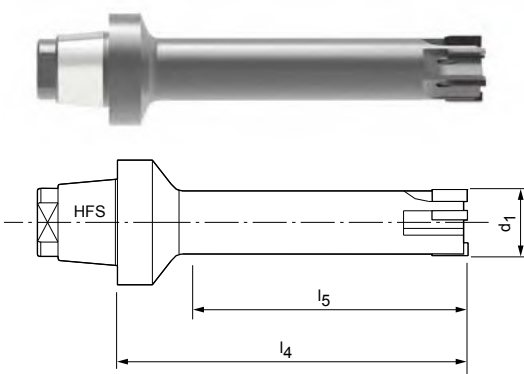
 metallo duro rivestito
in PVD

Caratteristiche configurabili

Diametro del foro tolleranza IT6:

- Diametro a libera scelta a passi da 0,001 mm
- Ordinabile in tolleranza IT6

Specifiche:

HPR230Ø[diametro][tolleranza]MC1G-HP421

Diametro del foro tolleranza < IT6:

- Tolleranze inferiori a IT6 ordinabili come diametro utensile speciale (per variante G vedere pagina 373)

Specifiche variante G:

HPR230GØ[diametro][tolleranza]MC1G-HP421

Dimensioni serie configurabile IT6

d ₁	l ₄	l ₅	Dimensione HFS	z
7,000 - 9,590	60	45	12	4
9,600 - 18,590	60	45	12	6

Esempio tolleranza IT6:

HPR230Ø10.350H6MC1G-HP421

 Diametro del foro d₁ = 10,350 H6

Esempio variante G:

HPR230GØ10.350+1-1MC1G-HP421

 Diametro utensile speciale d₁ = 10,350 +1 µm -1 µm

Misure in mm.

Supporto per testina intercambiabile HFS da pagina 460.

Per i parametri di lavorazione consigliati, vedere la fine del capitolo.

Alesatore a testina intercambiabile HPR

Versione con regolazione fine, scanalatura dritta, per foro passante
HPR230

Versione:

Diametro alesatore:

7,000 - 18,590 mm

Imbocco:

MC1G

Materiale da taglio:

HP423

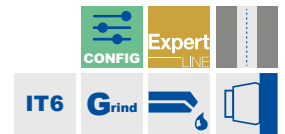
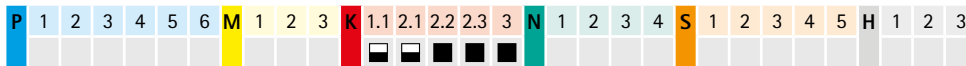
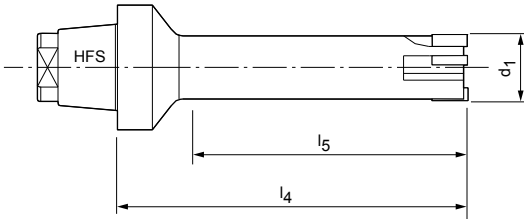
 metallo duro rivestito
in PVD

Caratteristiche configurabili

Diametro del foro tolleranza IT6:

- Diametro a libera scelta a passi da 0,001 mm
- Ordinabile in tolleranza IT6

Specifiche:

HPR230Ø[diametro][tolleranza]MC1G-HP423

Diametro del foro tolleranza < IT6:

- Tolleranze inferiori a IT6 ordinabili come diametro utensile speciale (per variante G vedere pagina 373)

Specifiche variante G:

HPR230GØ[diametro][tolleranza]MC1G-HP423

Dimensioni serie configurabile IT6

d ₁	l ₄	l ₅	Dimensione HFS	z
7,000 - 9,590	60	45	12	4
9,600 - 18,590	60	45	12	6

Esempio tolleranza IT6:

HPR230Ø10.350H6MC1G-HP423

 Diametro del foro d₁ = 10,350 H6

Esempio variante G:

HPR230GØ10.350+1-1MC1G-HP423

 Diametro utensile speciale d₁ = 10,350 +1 µm -1 µm

Misure in mm.

Supporto per testina intercambiabile HFS da pagina 460.

Per i parametri di lavorazione consigliati, vedere la fine del capitolo.

Alesatore a testina intercambiabile HPR

Versione con regolazione fine, scanalatura dritta, per foro passante
HPR230

Versione:

Diametro alesatore:

7,000 - 18,590 mm

Imbocco:

MA0A

Materiale da taglio:

PU620

Con riporto in PCD

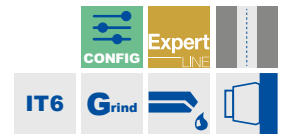
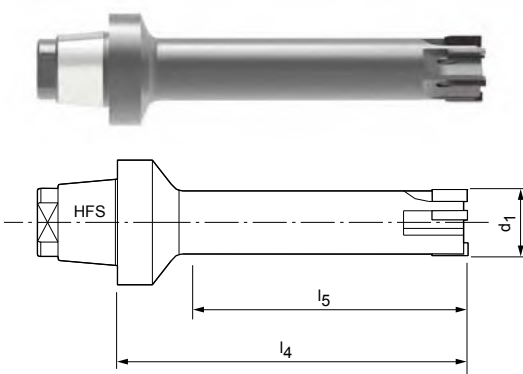

Caratteristiche configurabili

Diametro del foro tolleranza IT6:

- Diametro a libera scelta a passi da 0,001 mm
- Ordinabile in tolleranza IT6

Specifiche:

HPR230Ø[diametro][tolleranza]MA0A-PU620

Diametro del foro tolleranza < IT6:

- Tolleranze inferiori a IT6 ordinabili come diametro utensile speciale (per variante G vedere pagina 373)

Specifiche variante G:

HPR230GØ[diametro][tolleranza]MA0A-PU620

Dimensioni serie configurabile IT6

d_1	l_4	l_5	Dimensione HFS	z
7,000 - 9,590	60	45	12	4
9,600 - 18,590	60	45	12	6

Esempio tolleranza IT6:

HPR230Ø10.350H6MA0A-PU620

 Diametro del foro $d_1 = 10,350 \text{ H6}$
Esempio variante G:

HPR230GØ10.350+1-1MA0A-PU620

 Diametro utensile speciale $d_1 = 10,350 + 1 \mu\text{m} - 1 \mu\text{m}$

Misure in mm.

Supporto per testina intercambiabile HFS da pagina 460.

Per i parametri di lavorazione consigliati, vedere la fine del capitolo.

Alesatore a testina intercambiabile HPR

Versione con regolazione fine, scanalatura obliqua sinistra, per foro passante
HPR231

Versione:

Diametro alesatore:

7,000 - 18,590 mm

Imbocco:

ME1G

Materiale da taglio:

CU134

Cermet non rivestito

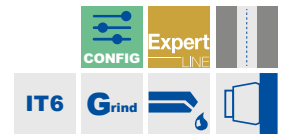
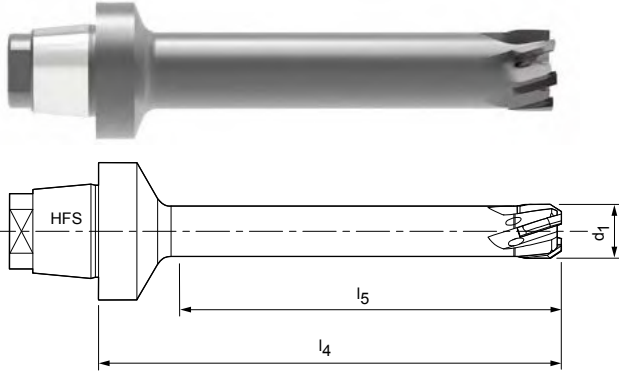

Caratteristiche configurabili

Diametro del foro tolleranza IT6:

- Diametro a libera scelta a passi da 0,001 mm
- Ordinabile in tolleranza IT6

Specifiche:

HPR231Ø[diametro][tolleranza]ME1G-CU134

Diametro del foro tolleranza < IT6:

- Tolleranze inferiori a IT6 ordinabili come diametro utensile speciale (per variante G vedere pagina 373)

Specifiche variante G:

HPR231GØ[diametro][tolleranza]ME1G-CU134

Dimensioni serie configurabile IT6

d ₁	l ₄	l ₅	Dimensione HFS	z
7,000 - 9,590	60	45	12	4
9,600 - 18,590	60	45	12	6

Esempio tolleranza IT6:

HPR231Ø10.350H6ME1G-CU134

 Diametro del foro d₁ = 10,350 H6

Esempio variante G:

HPR231GØ10.350+1-1ME1G-CU134

 Diametro utensile speciale d₁ = 10,350 +1 µm -1 µm

Misure in mm.

Supporto per testina intercambiabile HFS da pagina 460.

Per i parametri di lavorazione consigliati, vedere la fine del capitolo.

Alesatore a testina intercambiabile HPR

Versione con regolazione fine, scanalatura obliqua sinistra, per foro passante
HPR231

Versione:

Diametro alesatore:

7,000 - 18,590 mm

Imbocco:

ME1G

Materiale da taglio:

HP421

metallo duro rivestito

in PVD

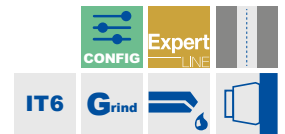
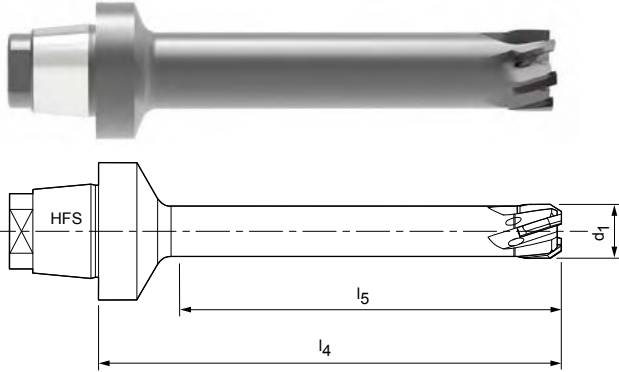
Caratteristiche configurabili

Diametro del foro tolleranza IT6:

- Diametro a libera scelta a passi da 0,001 mm
- Ordinabile in tolleranza IT6

Specifiche:

HPR231Ø[diametro][tolleranza]ME1G-HP421

Diametro del foro tolleranza < IT6:

- Tolleranze inferiori a IT6 ordinabili come diametro utensile speciale (per variante G vedere pagina 373)

Specifiche variante G:

HPR231GØ[diametro][tolleranza]ME1G-HP421

Dimensioni serie configurabile IT6

d ₁	l ₄	l ₅	Dimensione HFS	z
7,000 - 9,590	60	45	12	4
9,600 - 18,590	60	45	12	6

Esempio tolleranza IT6:

HPR231Ø10.350H6ME1G-HP421

 Diametro del foro d₁ = 10,350 H6

Esempio variante G:

HPR231GØ10.350+1-1ME1G-HP421

 Diametro utensile speciale d₁ = 10,350 +1 µm -1 µm

Misure in mm.

Supporto per testina intercambiabile HFS da pagina 460.

Per i parametri di lavorazione consigliati, vedere la fine del capitolo.

Alesatore a testina intercambiabile HPR

Versione con regolazione fine, scanalatura obliqua sinistra, per foro passante
HPR231

Versione:

Diametro alesatore:

7,000 - 18,590 mm

Imbocco:

MF1G

Materiale da taglio:

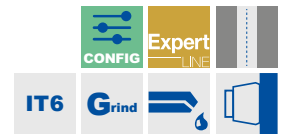
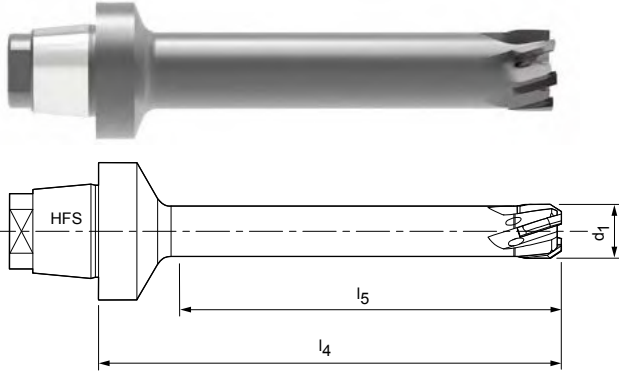
 HP421
 metallo duro rivestito
 in PVD

Caratteristiche configurabili

Diametro del foro tolleranza IT6:

- Diametro a libera scelta a passi da 0,001 mm
- Ordinabile in tolleranza IT6

Specifiche:

HPR231Ø[diametro][tolleranza]MF1G-HP421

Diametro del foro tolleranza < IT6:

- Tolleranze inferiori a IT6 ordinabili come diametro utensile speciale (per variante G vedere pagina 373)

Specifiche variante G:

HPR231GØ[diametro][tolleranza]MF1G-HP421

Dimensioni serie configurabile IT6

d ₁	l ₄	l ₅	Dimensione HFS	z
7,000 - 9,590	60	45	12	4
9,600 - 18,590	60	45	12	6

Esempio tolleranza IT6:

HPR231Ø10.350H6MF1G-HP421

 Diametro del foro d₁ = 10,350 H6

Esempio variante G:

HPR231GØ10.350+1-1MF1G-HP421

 Diametro utensile speciale d₁ = 10,350 +1 µm -1 µm

Misure in mm.

Supporto per testina intercambiabile HFS da pagina 460.

Per i parametri di lavorazione consigliati, vedere la fine del capitolo.

Alesatore a testina intercambiabile HPR

Versione con regolazione fine, scanalatura obliqua sinistra, per foro passante
HPR231

Versione:

Diametro alesatore:

7,000 - 18,590 mm

Imbocco:

MF1G

Materiale da taglio:

HP625

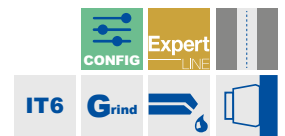
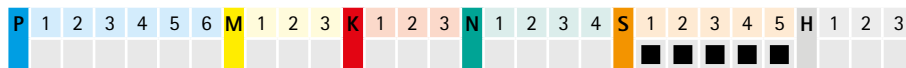
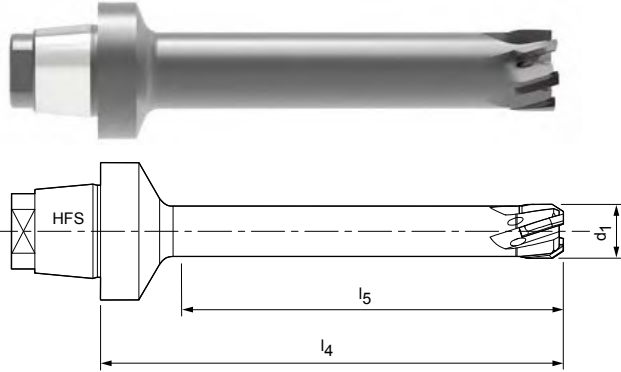
 metallo duro rivestito
in PVD

Caratteristiche configurabili

Diametro del foro tolleranza IT6:

- Diametro a libera scelta a passi da 0,001 mm
- Ordinabile in tolleranza IT6

Specifiche:

HPR231Ø[diametro][tolleranza]MF1G-HP625

Diametro del foro tolleranza < IT6:

- Tolleranze inferiori a IT6 ordinabili come diametro utensile speciale (per variante G vedere pagina 373)

Specifiche variante G:

HPR231GØ[diametro][tolleranza]MF1G-HP625

Dimensioni serie configurabile IT6

d ₁	l ₄	l ₅	Dimensione HFS	z
7,000 - 9,590	60	45	12	4
9,600 - 18,590	60	45	12	6

Esempio tolleranza IT6:

HPR231Ø10.350H6MF1G-HP625

 Diametro del foro d₁ = 10,350 H6

Esempio variante G:

HPR231GØ10.350+1-1MF1G-HP625

 Diametro utensile speciale d₁ = 10,350 +1 µm -1 µm

Misure in mm.

Supporto per testina intercambiabile HFS da pagina 460.

Per i parametri di lavorazione consigliati, vedere la fine del capitolo.

Alesatore a testina intercambiabile HPR

Versione con regolazione fine, scanalatura dritta, per foro passante
HPR200

Versione:

Diametro alesatore:

18,600 - 65,000 mm

Imbocco:

MC1G

Materiale da taglio:

CP134

Cermet rivestito in

PVD

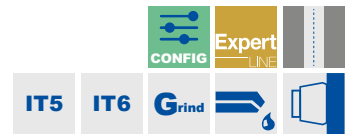
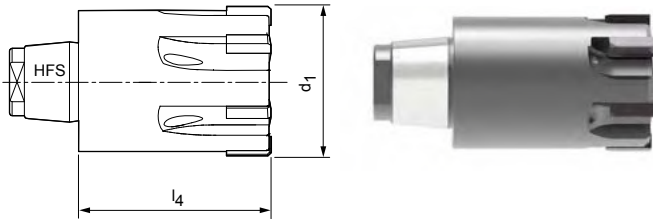

Caratteristiche configurabili

Diametro del foro tolleranza IT5/IT6:

- Diametro a libera scelta a passi da 0,001 mm
- Ordinabile in funzione del range di diametro a partire da tolleranze IT5/IT6
- > 030,000 IT5 | ≤ 030,000 IT6

Specifiche:

HPR200Ø[diametro][tolleranza]MC1G-CP134

Diametro del foro tolleranza < IT5/IT6:

- Tolleranze inferiori a IT5/IT6 ordinabili come diametro utensile speciale (per variante G vedere pagina 373)

Specifiche variante G:

HPR200GØ[diametro][tolleranza]MC1G-CP134

Dimensioni serie configurabile IT5/IT6

d ₁	l ₄	l ₅	Dimensione HFS	z	Tolleranza
18,600 - 20,390	25	-	12	6	IT6
20,400 - 21,290	27	-	12	6	IT6
21,300 - 23,990	27	-	14	6	IT6
24,000 - 29,990	35	-	16	6	IT6
30,000 - 39,990	41	-	20	8	IT5
40,000 - 65,000	47	-	24	8	IT5

Esempio tolleranza IT5:

HPR200Ø35.350H5MC1G-CP134

 Diametro del foro d₁ = 35,350 H5

Esempio variante G:

HPR200GØ35.350+1-1MC1G-CP134

 Diametro utensile speciale d₁ = 35,350 +1 µm -1 µm

Misure in mm.

 * per superfici R_a < 2 µm

Supporto per testina intercambiabile HFS da pagina 460.

Per i parametri di lavorazione consigliati, vedere la fine del capitolo.

Alesatore a testina intercambiabile HPR

Versione con regolazione fine, scanalatura dritta, per foro passante
HPR200

Versione:

Diametro alesatore:

18,600 - 65,000 mm

Imbocco:

MC1G

Materiale da taglio:

HP421

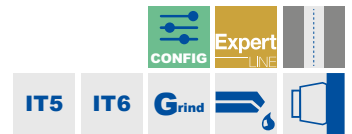
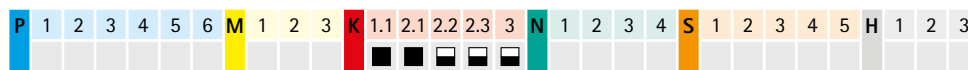
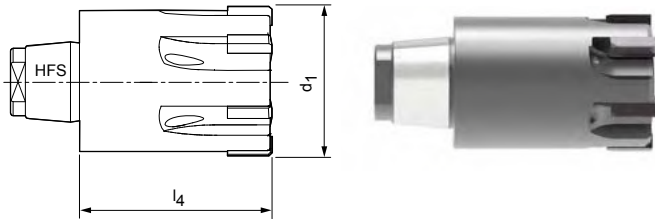
 metallo duro rivestito
in PVD

Caratteristiche configurabili



Diametro del foro tolleranza IT5/IT6:

- Diametro a libera scelta a passi da 0,001 mm
- Ordinabile in funzione del range di diametro a partire da tolleranze IT5/IT6
- > 030,000 IT5 | ≤ 030,000 IT6

Specifiche:

HPR200Ø[diametro][tolleranza]MC1G-HP421

Diametro del foro tolleranza < IT5/IT6:

- Tolleranze inferiori a IT5/IT6 ordinabili come diametro utensile speciale (per variante G vedere pagina 373)

Specifiche variante G:

HPR200GØ[diametro][tolleranza]MC1G-HP421

Dimensioni serie configurabile IT5/IT6

d ₁	l ₄	l ₅	Dimensione HFS	z	Tolleranza
18,600 - 20,390	25	-	12	6	IT6
20,400 - 21,290	27	-	12	6	IT6
21,300 - 23,990	27	-	14	6	IT6
24,000 - 29,990	35	-	16	6	IT6
30,000 - 39,990	41	-	20	8	IT5
40,000 - 65,000	47	-	24	8	IT5

Esempio tolleranza IT5:

HPR200Ø35.350H5MC1G-HP421

 Diametro del foro d₁ = 35,350 H5

Esempio variante G:

HPR200GØ35.350+1-1MC1G-HP421

 Diametro utensile speciale d₁ = 35,350 +1 μm -1 μm

Misure in mm.

Supporto per testina intercambiabile HFS da pagina 460.

Per i parametri di lavorazione consigliati, vedere la fine del capitolo.

Alesatore a testina intercambiabile HPR

Versione con regolazione fine, scanalatura dritta, per foro passante
HPR200

Versione:

Diametro alesatore:

18,600 - 65,000 mm

Imbocco:

MC1G

Materiale da taglio:

HP423

metallo duro rivestito

in PVD

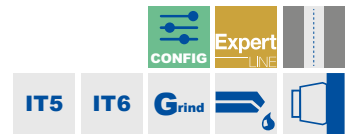
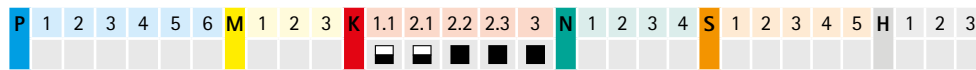
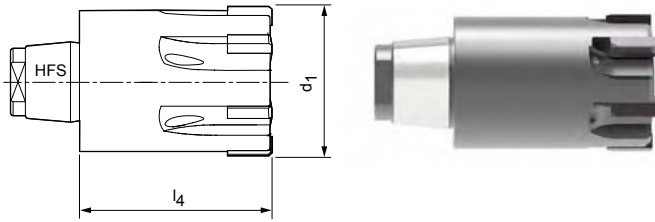
Caratteristiche configurabili

Diametro del foro tolleranza IT5/IT6:

- Diametro a libera scelta a passi da 0,001 mm
- Ordinabile in funzione del range di diametro a partire da tolleranze IT5/IT6
- > 030,000 IT5 | ≤ 030,000 IT6

Specifiche:

HPR200Ø[diametro][tolleranza]MC1G-HP423

Diametro del foro tolleranza < IT5/IT6:

- Tolleranze inferiori a IT5/IT6 ordinabili come diametro utensile speciale (per variante G vedere pagina 373)

Specifiche variante G:

HPR200GØ[diametro][tolleranza]MC1G-HP423

Dimensioni serie configurabile IT5/IT6

d ₁	l ₄	l ₅	Dimensione HFS	z	Tolleranza
18,600 - 20,390	25	-	12	6	IT6
20,400 - 21,290	27	-	12	6	IT6
21,300 - 23,990	27	-	14	6	IT6
24,000 - 29,990	35	-	16	6	IT6
30,000 - 39,990	41	-	20	8	IT5
40,000 - 65,000	47	-	24	8	IT5

Esempio tolleranza IT5:

HPR200Ø35.350H5MC1G-HP423

 Diametro del foro d₁ = 35,350 H5

Esempio variante G:

HPR200GØ35.350+1-1MC1G-HP423

 Diametro utensile speciale d₁ = 35,350 +1 µm -1 µm

Misure in mm.

Supporto per testina intercambiabile HFS da pagina 460.

Per i parametri di lavorazione consigliati, vedere la fine del capitolo.

Alesatore a testina intercambiabile HPR

Versione con regolazione fine, scanalatura dritta, per foro passante
HPR200

Versione:

Diametro alesatore:

18,600 - 65,000 mm

Imbocco:

MA0A

Materiale da taglio:

PU620

Con riporto in PCD

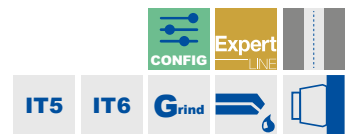
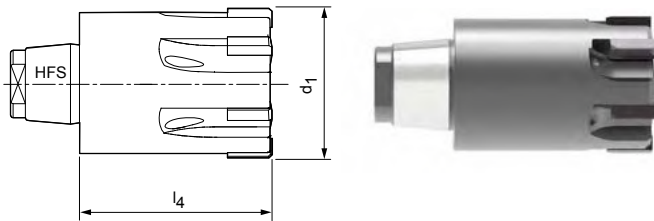

Caratteristiche configurabili



Diametro del foro tolleranza IT5/IT6:

- Diametro a libera scelta a passi da 0,001 mm
- Ordinabile in funzione del range di diametro a partire da tolleranze IT5/IT6
- > 030,000 IT5 | ≤ 030,000 IT6

Specifiche:

HPR200Ø[diametro][tolleranza]MA0A-PU620

Diametro del foro tolleranza < IT5/IT6:

- Tolleranze inferiori a IT5/IT6 ordinabili come diametro utensile speciale (per variante G vedere pagina 373)

Specifiche variante G:

HPR200GØ[diametro][tolleranza]MA0A-PU620

Dimensioni serie configurabile IT5/IT6

d ₁	l ₄	l ₅	Dimensione HFS	z	Tolleranza
18,600 - 20,390	25	-	12	6	IT6
20,400 - 21,290	27	-	12	6	IT6
21,300 - 23,990	27	-	14	6	IT6
24,000 - 29,990	35	-	16	6	IT6
30,000 - 39,990	41	-	20	8	IT5
40,000 - 65,000	47	-	24	8	IT5

Esempio tolleranza IT5:

HPR200Ø35.350H5MA0A-PU620

Diametro del foro d₁ = 35,350 H5

Esempio variante G:

HPR200GØ35.350+1-1MA0A-PU620

Diametro utensile speciale d₁ = 35,350 +1 µm -1 µm

Misure in mm.

Supporto per testina intercambiabile HFS da pagina 460.

Per i parametri di lavorazione consigliati, vedere la fine del capitolo.

Alesatore a testina intercambiabile HPR

Versione con regolazione fine, scanalatura obliqua sinistra, per foro passante HPR210

Versione:

Diametro alesatore:

18,600 - 65,000 mm

Imbocco:

ME1G

Materiale da taglio:

CU134

Cermet non rivestito

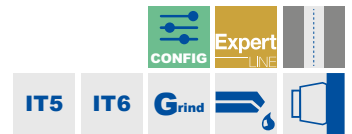
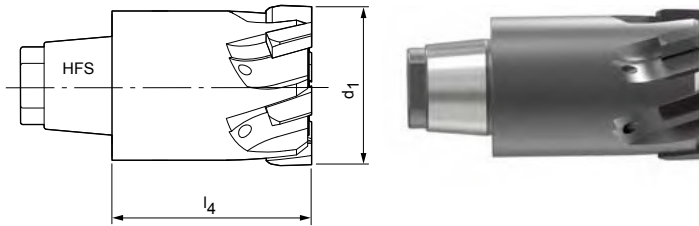

Caratteristiche configurabili

Diametro del foro tolleranza IT5/IT6:

- Diametro a libera scelta a passi da 0,001 mm
- Ordinabile in funzione del range di diametro a partire da tolleranze IT5/IT6
- > 030,000 IT5 | ≤ 030,000 IT6

Specifiche:

HPR210Ø[diametro][tolleranza]ME1G-CU134

Diametro del foro tolleranza < IT5/IT6:

- Tolleranze inferiori a IT5/IT6 ordinabili come diametro utensile speciale (per variante G vedere pagina 373)

Specifiche variante G:

HPR210GØ[diametro][tolleranza]ME1G-CU134

Dimensioni serie configurabile IT5/IT6

d ₁	l ₄	l ₅	Dimensione HFS	z	Tolleranza
18,600 - 20,390	25	-	12	6	IT6
20,400 - 21,290	27	-	12	6	IT6
21,300 - 23,990	27	-	14	6	IT6
24,000 - 29,990	35	-	16	6	IT6
30,000 - 39,990	41	-	20	8	IT5
40,000 - 65,000	47	-	24	8	IT5

Esempio tolleranza IT5:

HPR210Ø35.350H5ME1G-CU134

 Diametro del foro d₁ = 35,350 H5

Esempio variante G:

HPR210GØ35.350+1-1ME1G-CU134

 Diametro utensile speciale d₁ = 35,350 +1 µm -1 µm

Misure in mm.

Supporto per testina intercambiabile HFS da pagina 460.

Per i parametri di lavorazione consigliati, vedere la fine del capitolo.

Alesatore a testina intercambiabile HPR

Versione con regolazione fine, scanalatura obliqua sinistra, per foro passante HPR210

Versione:

Diametro alesatore:

18,600 - 65,000 mm

Imbocco:

ME1G

Materiale da taglio:

HP421
metallo duro rivestito
in PVD

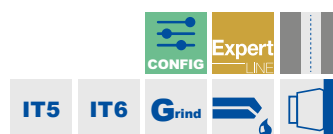
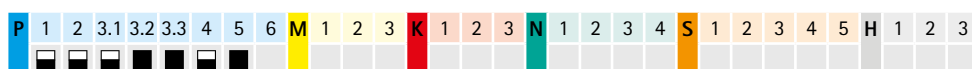
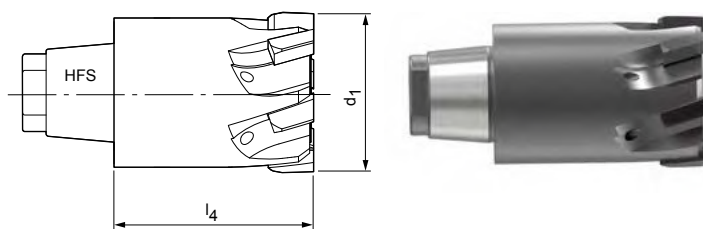

Caratteristiche configurabili



Diametro del foro tolleranza IT5/IT6:

- Diametro a libera scelta a passi da 0,001 mm
- Ordinabile in funzione del range di diametro a partire da tolleranze IT5/IT6
- > 030,000 IT5 | ≤ 030,000 IT6

Specifiche:

HPR210Ø[diametro][tolleranza]ME1G-HP421

Diametro del foro tolleranza < IT5/IT6:

- Tolleranze inferiori a IT5/IT6 ordinabili come diametro utensile speciale (per variante G vedere pagina 373)

Specifiche variante G:

HPR210GØ[diametro][tolleranza]ME1G-HP421

Dimensioni serie configurabile IT5/IT6

d ₁	l ₄	l ₅	Dimensione HFS	z	Tolleranza
18,600 - 20,390	25	-	12	6	IT6
20,400 - 21,290	27	-	12	6	IT6
21,300 - 23,990	27	-	14	6	IT6
24,000 - 29,990	35	-	16	6	IT6
30,000 - 39,990	41	-	20	8	IT5
40,000 - 65,000	47	-	24	8	IT5

Esempio tolleranza IT5:

HPR210Ø35.350H5ME1G-HP421

Diametro del foro d₁ = 35,350 H5

Esempio variante G:

HPR210GØ35.350+1-1ME1G-HP421

Diametro utensile speciale d₁ = 35,350 +1 µm -1 µm

Misure in mm.

Supporto per testina intercambiabile HFS da pagina 460.

Per i parametri di lavorazione consigliati, vedere la fine del capitolo.

Alesatore a testina intercambiabile HPR

Versione con regolazione fine, scanalatura obliqua sinistra, per foro passante HPR210

Versione:

Diametro alesatore:

18,600 - 65,000 mm

Imbocco:

MF1G

Materiale da taglio:

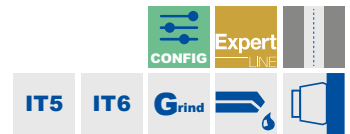
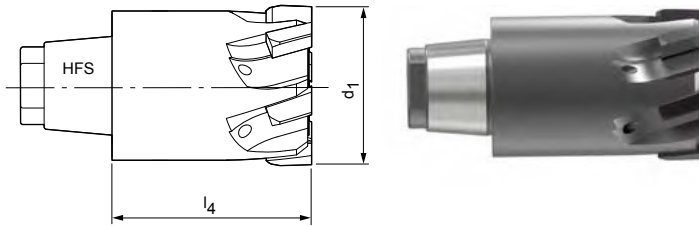
 HP421
 metallo duro rivestito
 in PVD

Caratteristiche configurabili



Diametro del foro tolleranza IT5/IT6:

- Diametro a libera scelta a passi da 0,001 mm
- Ordinabile in funzione del range di diametro a partire da tolleranze IT5/IT6
- > 030,000 IT5 | ≤ 030,000 IT6

Specifiche:

HPR210Ø[diametro][tolleranza]MF1G-HP421

Diametro del foro tolleranza < IT5/IT6:

- Tolleranze inferiori a IT5/IT6 ordinabili come diametro utensile speciale (per variante G vedere pagina 373)

Specifiche variante G:

HPR210GØ[diametro][tolleranza]MF1G-HP421

Dimensioni serie configurabile IT5/IT6

d ₁	l ₄	l ₅	Dimensione HFS	z	Tolleranza
18,600 - 20,390	25	-	12	6	IT6
20,400 - 21,290	27	-	12	6	IT6
21,300 - 23,990	27	-	14	6	IT6
24,000 - 29,990	35	-	16	6	IT6
30,000 - 39,990	41	-	20	8	IT5
40,000 - 65,000	47	-	24	8	IT5

Esempio tolleranza IT5:

HPR210Ø35.350H5MF1G-HP421

Diametro del foro d₁ = 35,350 H5

Esempio variante G:

HPR210GØ35.350+1-1MF1G-HP421

Diametro utensile speciale d₁ = 35,350 +1 µm -1 µm

Misure in mm.

Supporto per testina intercambiabile HFS da pagina 460.

Per i parametri di lavorazione consigliati, vedere la fine del capitolo.

Alesatore a testina intercambiabile HPR

Versione con regolazione fine, scanalatura obliqua sinistra, per foro passante HPR210

Versione:

Diametro alesatore:

18,600 - 65,000 mm

Imbocco:

MF1G

Materiale da taglio:

HP625
metallo duro rivestito
in PVD

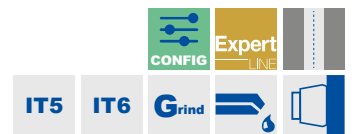
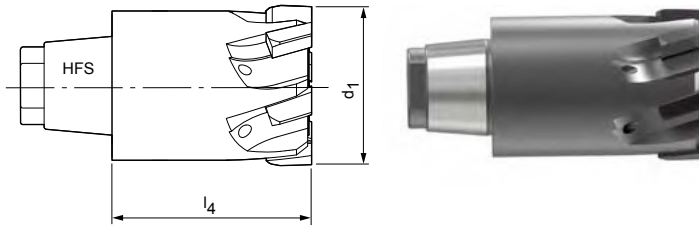

Caratteristiche configurabili



Diametro del foro tolleranza IT5/IT6:

- Diametro a libera scelta a passi da 0,001 mm
- Ordinabile in funzione del range di diametro a partire da tolleranze IT5/IT6
- > 030,000 IT5 | ≤ 030,000 IT6

Specifiche:

HPR210Ø[diametro][tolleranza]MF1G-HP625

Diametro del foro tolleranza < IT5/IT6:

- Tolleranze inferiori a IT5/IT6 ordinabili come diametro utensile speciale (per variante G vedere pagina 373)

Specifiche variante G:

HPR210GØ[diametro][tolleranza]MF1G-HP625

Dimensioni serie configurabile IT5/IT6

d ₁	l ₄	l ₅	Dimensione HFS	z	Tolleranza
18,600 - 20,390	25	-	12	6	IT6
20,400 - 21,290	27	-	12	6	IT6
21,300 - 23,990	27	-	14	6	IT6
24,000 - 29,990	35	-	16	6	IT6
30,000 - 39,990	41	-	20	8	IT5
40,000 - 65,000	47	-	24	8	IT5

Esempio tolleranza IT5:

HPR210Ø35.350H5MF1G-HP625

Diametro del foro d₁ = 35,350 H5

Esempio variante G:

HPR210GØ35.350+1-1MF1G-HP625

Diametro utensile speciale d₁ = 35,350 +1 µm -1 µm

Misure in mm.

Supporto per testina intercambiabile HFS da pagina 460.

Per i parametri di lavorazione consigliati, vedere la fine del capitolo.

Alesatore a testina intercambiabile HPR

Versione con regolazione fine, scanalatura dritta, per foro cieco
HPR280

Versione:

Diametro alesatore:

7,000 - 21,290 mm

Imbocco:

ML2G

Materiale da taglio:

CU134

Cermet non rivestito

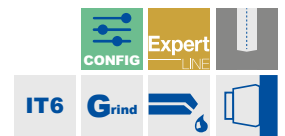
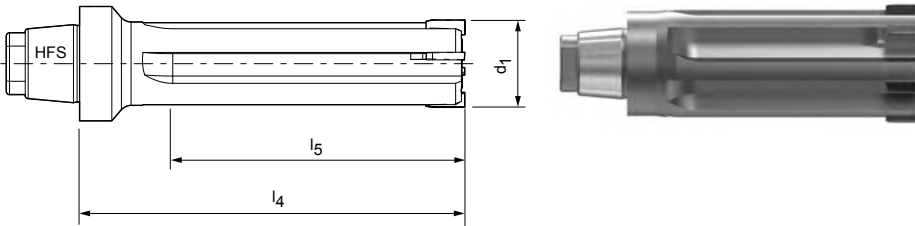
Caratteristiche configurabili

Diametro del foro tolleranza IT6:

- Diametro a libera scelta a passi da 0,001 mm
- Ordinabile in tolleranza IT6

Specifiche:

HPR280Ø[diametro][tolleranza]ML2G-CU134

Diametro del foro tolleranza < IT6:

- Tolleranze inferiori a IT6 ordinabili come diametro utensile speciale (per variante G vedere pagina 373)

Specifiche variante G:

HPR280GØ[diametro][tolleranza]ML2G-CU134

Dimensioni serie configurabile IT6

d ₁	l ₄	l ₅	Dimensione HFS	z
7,000 - 14,590	60	40	12	4
14,600 - 21,290	60	40	12	6

Esempio tolleranza IT6:

HPR280Ø16.350H6ML2G-CU134

 Diametro del foro d₁ = 16,350 H6

Esempio variante G:

HPR280GØ16.350+1-1ML2G-CU134

 Diametro utensile speciale d₁ = 16,350 +1 µm -1 µm

Misure in mm.

Supporto per testina intercambiabile HFS da pagina 460.

Per i parametri di lavorazione consigliati, vedere la fine del capitolo.

Alesatore a testina intercambiabile HPR

Versione con regolazione fine, scanalatura dritta, per foro cieco
HPR280

Versione:

Diametro alesatore:

7,000 - 21,290 mm

Imbocco:

ML2G

Materiale da taglio:

metallo duro rivestito

in PVD

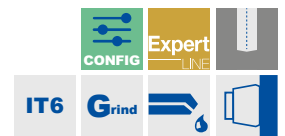
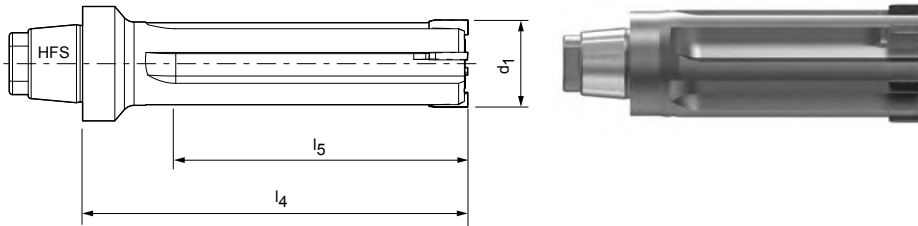

Caratteristiche configurabili

Diametro del foro tolleranza IT6:

- Diametro a libera scelta a passi da 0,001 mm
- Ordinabile in tolleranza IT6

Specifiche:

HPR280Ø[diametro][tolleranza]ML2G-HP421

Diametro del foro tolleranza < IT6:

- Tolleranze inferiori a IT6 ordinabili come diametro utensile speciale (per variante G vedere pagina 373)

Specifiche variante G:

HPR280GØ[diametro][tolleranza]ML2G-HP421

Dimensioni serie configurabile IT6

d ₁	l ₄	l ₅	Dimensione HFS	z
7,000 - 14,590	60	40	12	4
14,600 - 21,290	60	40	12	6

Esempio tolleranza IT6:

HPR280Ø16.350H6ML2G-HP421

 Diametro del foro d₁ = 16,350 H6

Esempio variante G:

HPR280GØ16.350+1-1ML2G-HP421

 Diametro utensile speciale d₁ = 16,350 +1 µm -1 µm

Misure in mm.

Supporto per testina intercambiabile HFS da pagina 460.

Per i parametri di lavorazione consigliati, vedere la fine del capitolo.

Alesatore a testina intercambiabile HPR

Versione con regolazione fine, scanalatura dritta, per foro cieco
HPR280

Versione:

Diametro alesatore:

7,000 - 21,290 mm

Imbocco:

M02G

Materiale da taglio:

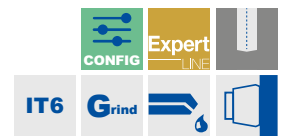
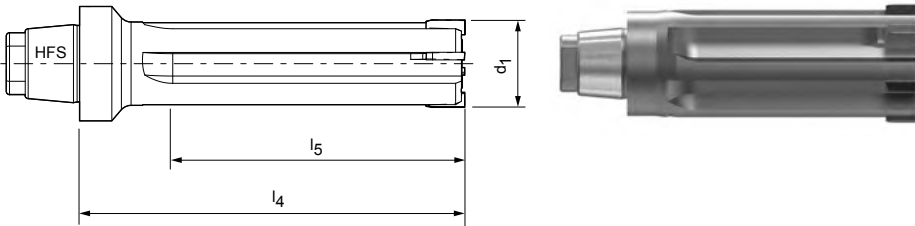
 metallo duro rivestito
in PVD

Caratteristiche configurabili

Diametro del foro tolleranza IT6:

- Diametro a libera scelta a passi da 0,001 mm
- Ordinabile in tolleranza IT6

Specifiche:

HPR280Ø[diametro][tolleranza]M02G-HP421

Diametro del foro tolleranza < IT6:

- Tolleranze inferiori a IT6 ordinabili come diametro utensile speciale (per variante G vedere pagina 373)

Specifiche variante G:

HPR280GØ[diametro][tolleranza]M02G-HP421

Dimensioni serie configurabile IT6

d ₁	l ₄	l ₅	Dimensione HFS	z
7,000 - 14,590	60	40	12	4
14,600 - 21,290	60	40	12	6

Esempio tolleranza IT6:

HPR280Ø16.350H6M02G-HP421

 Diametro del foro d₁ = 16,350 H6

Esempio variante G:

HPR280GØ16.350+1-1M02G-HP421

 Diametro utensile speciale d₁ = 16,350 +1 µm -1 µm

Misure in mm.

Supporto per testina intercambiabile HFS da pagina 460.

Per i parametri di lavorazione consigliati, vedere la fine del capitolo.

Alesatore a testina intercambiabile HPR

Versione con regolazione fine, scanalatura dritta, per foro cieco
HPR280

Versione:

Diametro alesatore:

7,000 - 21,290 mm

Imbocco:

MC1G

Materiale da taglio:

CP134

Cermet rivestito in

PVD

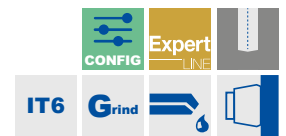
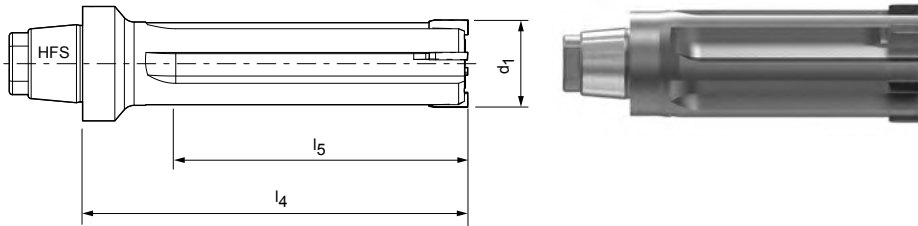

Caratteristiche configurabili

Diametro del foro tolleranza IT6:

- Diametro a libera scelta a passi da 0,001 mm
- Ordinabile in tolleranza IT6

Specifiche:

HPR280Ø[diametro][tolleranza]MC1G-CP134

Diametro del foro tolleranza < IT6:

- Tolleranze inferiori a IT6 ordinabili come diametro utensile speciale (per variante G vedere pagina 373)

Specifiche variante G:

HPR280GØ[diametro][tolleranza]MC1G-CP134

Dimensioni serie configurabile IT6

d_1	l_4	l_5	Dimensione HFS	z
7,000 - 14,590	60	40	12	4
14,600 - 21,290	60	40	12	6

Esempio tolleranza IT6:

HPR280Ø16.350H6MC1G-CP134

 Diametro del foro $d_1 = 16,350 H6$
Esempio variante G:

HPR280GØ16.350+1-1MC1G-CP134

 Diametro utensile speciale $d_1 = 16,350 +1 \mu\text{m} -1 \mu\text{m}$

Misure in mm.

 * per superfici $R_a < 2 \mu\text{m}$

Supporto per testina intercambiabile HFS da pagina 460.

Per i parametri di lavorazione consigliati, vedere la fine del capitolo.

Alesatore a testina intercambiabile HPR

Versione con regolazione fine, scanalatura dritta, per foro cieco
HPR280

Versione:

Diametro alesatore:

7,000 - 21,290 mm

Imbocco:

MC1G

Materiale da taglio:

metallo duro rivestito

in PVD

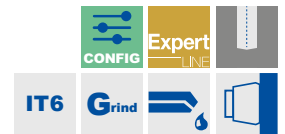
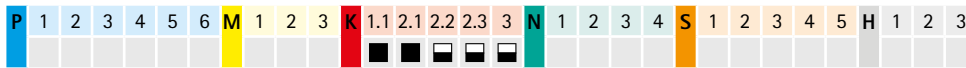
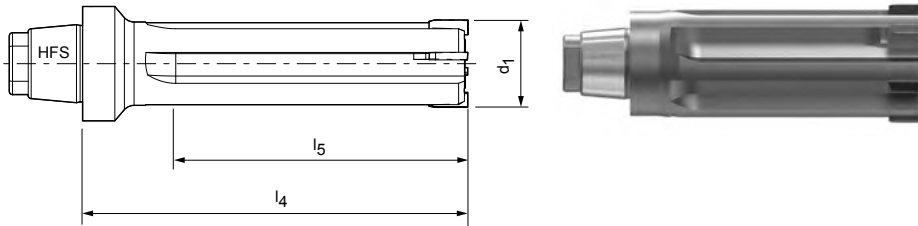
Caratteristiche configurabili

Diametro del foro tolleranza IT6:

- Diametro a libera scelta a passi da 0,001 mm
- Ordinabile in tolleranza IT6

Specifiche:

HPR280Ø[diametro][tolleranza]MC1G-HP421

Diametro del foro tolleranza < IT6:

- Tolleranze inferiori a IT6 ordinabili come diametro utensile speciale (per variante G vedere pagina 373)

Specifiche variante G:

HPR280GØ[diametro][tolleranza]MC1G-HP421

Dimensioni serie configurabile IT6

d ₁	l ₄	l ₅	Dimensione HFS	z
7,000 - 14,590	60	40	12	4
14,600 - 21,290	60	40	12	6

Esempio tolleranza IT6:

HPR280Ø16.350H6MC1G-HP421

 Diametro del foro d₁ = 16,350 H6

Esempio variante G:

HPR280GØ16.350+1-1MC1G-HP421

 Diametro utensile speciale d₁ = 16,350 +1 µm -1 µm

Misure in mm.

Supporto per testina intercambiabile HFS da pagina 460.

Per i parametri di lavorazione consigliati, vedere la fine del capitolo.

Alesatore a testina intercambiabile HPR

Versione con regolazione fine, scanalatura dritta, per foro cieco
HPR280

Versione:

Diametro alesatore:

7,000 - 21,290 mm

Imbocco:

MC1G

Materiale da taglio:

metallo duro rivestito

in PVD

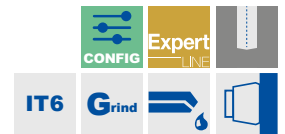
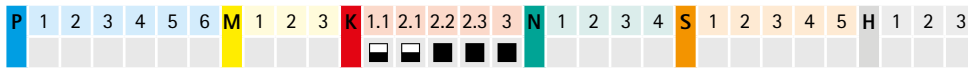
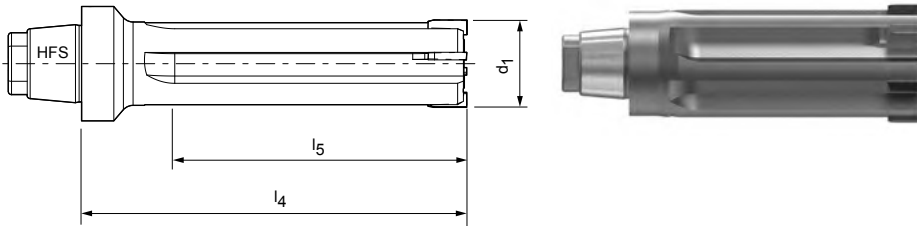

Caratteristiche configurabili

Diametro del foro tolleranza IT6:

- Diametro a libera scelta a passi da 0,001 mm
- Ordinabile in tolleranza IT6

Specifiche:

HPR280Ø[diametro][tolleranza]MC1G-HP423

Diametro del foro tolleranza < IT6:

- Tolleranze inferiori a IT6 ordinabili come diametro utensile speciale (per variante G vedere pagina 373)

Specifiche variante G:

HPR280GØ[diametro][tolleranza]MC1G-HP423

Dimensioni serie configurabile IT6

d_1	l_4	l_5	Dimensione HFS	z
7,000 - 14,590	60	40	12	4
14,600 - 21,290	60	40	12	6

Esempio tolleranza IT6:

HPR280Ø16.350H6MC1G-HP423

 Diametro del foro $d_1 = 16,350 \text{ H6}$
Esempio variante G:

HPR280GØ16.350+1-1MC1G-HP423

 Diametro utensile speciale $d_1 = 16,350 +1 \mu\text{m} -1 \mu\text{m}$

Misure in mm.

Supporto per testina intercambiabile HFS da pagina 460.

Per i parametri di lavorazione consigliati, vedere la fine del capitolo.

Alesatore a testina intercambiabile HPR

Versione con regolazione fine, scanalatura dritta, per foro cieco
HPR280

Versione:

Diametro alesatore:

7,000 - 21,290 mm

Imbocco:

MA0A

Materiale da taglio:

PU620

Con riporto in PCD

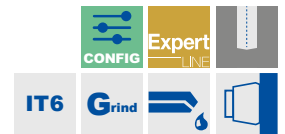
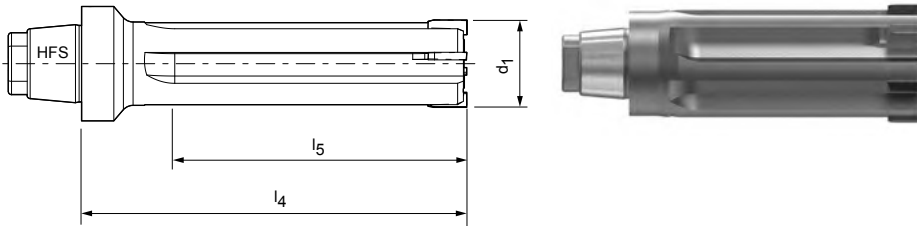

Caratteristiche configurabili

Diametro del foro tolleranza IT6:

- Diametro a libera scelta a passi da 0,001 mm
- Ordinabile in tolleranza IT6

Specifiche:

HPR280Ø[diametro][tolleranza]MA0A-PU620

Diametro del foro tolleranza < IT6:

- Tolleranze inferiori a IT6 ordinabili come diametro utensile speciale (per variante G vedere pagina 373)

Specifiche variante G:

HPR280GØ[diametro][tolleranza]MA0A-PU620

Dimensioni serie configurabile IT6

d ₁	l ₄	l ₅	Dimensione HFS	z
7,000 - 14,590	60	40	12	4
14,600 - 21,290	60	40	12	6

Esempio tolleranza IT6:

HPR280Ø16.350H6MA0A-PU620

 Diametro del foro d₁ = 16,350 H6

Esempio variante G:

HPR280GØ16.350+1-1MA0A-PU620

 Diametro utensile speciale d₁ = 16,350 +1 µm -1 µm

Misure in mm.

Supporto per testina intercambiabile HFS da pagina 460.

Per i parametri di lavorazione consigliati, vedere la fine del capitolo.

Alesatore a testina intercambiabile HPR

Versione con regolazione fine, scanalatura dritta, per foro cieco
HPR280

Versione:

Diametro alesatore:

7,000 - 21,290 mm

Imbocco:

M02G

Materiale da taglio:

metallo duro rivestito

in PVD

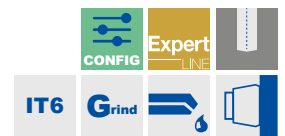
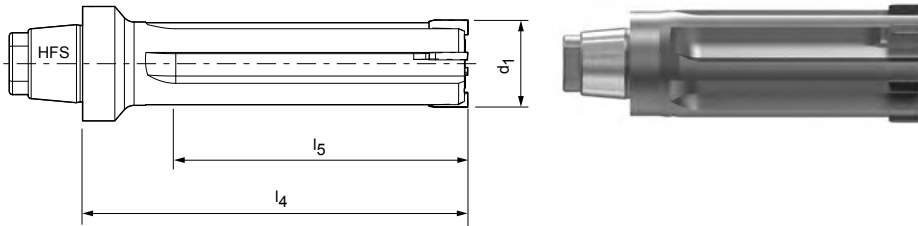

Caratteristiche configurabili

Diametro del foro tolleranza IT6:

- Diametro a libera scelta a passi da 0,001 mm
- Ordinabile in tolleranza IT6

Specifiche:

HPR280Ø[diametro][tolleranza]M02G-HP625

Diametro del foro tolleranza < IT6:

- Tolleranze inferiori a IT6 ordinabili come diametro utensile speciale (per variante G vedere pagina 373)

Specifiche variante G:

HPR280GØ[diametro][tolleranza]M02G-HP625

Dimensioni serie configurabile IT6

d_1	l_4	l_5	Dimensione HFS	z
7,000 - 14,590	60	40	12	4
14,600 - 21,290	60	40	12	6

Esempio tolleranza IT6:

HPR280Ø16.350H6M02G-HP625

 Diametro del foro $d_1 = 16,350 \text{ H6}$
Esempio variante G:

HPR280GØ16.350+1-1M02G-HP625

 Diametro utensile speciale $d_1 = 16,350 +1 \mu\text{m} -1 \mu\text{m}$

Misure in mm.

Supporto per testina intercambiabile HFS da pagina 460.

Per i parametri di lavorazione consigliati, vedere la fine del capitolo.

Alesatore a testina intercambiabile HPR

Versione con regolazione fine, scanalatura dritta, per foro cieco
HPR250

Versione:

Diametro alesatore:

16,600 - 65,000 mm

Imbocco:

ML2G

Materiale da taglio:

CU134

Cermet non rivestito

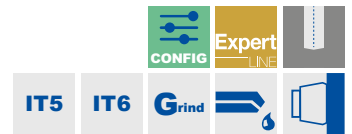
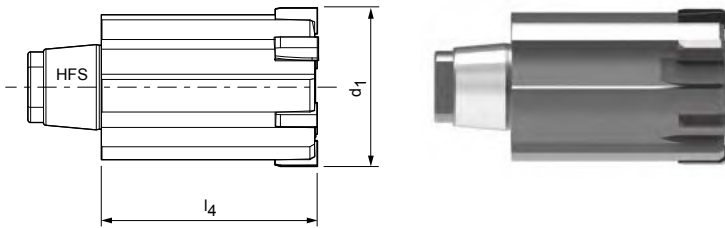
Caratteristiche configurabili

Diametro del foro tolleranza IT5/IT6:

- Diametro a libera scelta a passi da 0,001 mm
- Ordinabile in funzione del range di diametro a partire da tolleranze IT5/IT6
- > 030,000 IT5 | ≤ 030,000 IT6

Specifiche:

HPR250Ø[diametro][tolleranza]ML2G-CU134

Diametro del foro tolleranza < IT5/IT6:

- Tolleranze inferiori a IT5/IT6 ordinabili come diametro utensile speciale (per variante G vedere pagina 373)

Specifiche variante G:

HPR250GØ[diametro][tolleranza]ML2G-CU134

Dimensioni serie configurabile IT5/IT6

d ₁	l ₄	l ₅	Dimensione HFS	z	Tolleranza
16,600 - 21,290	25	-	10	6	IT6
21,300 - 24,990	27	-	12	6	IT6
25,000 - 28,590	35	-	14	6	IT6
29,000 - 32,290	35	-	16	6	IT5
32,300 - 36,990	41	-	16	6	IT5
37,000 - 41,190	41	-	20	8	IT5
41,200 - 44,900	47	-	20	8	IT5
45,000 - 65,000	47	-	24	8	IT5

Esempio tolleranza IT5:

HPR250Ø35.350H5ML2G-CU134

 Diametro del foro d₁ = 35,350 H5

Esempio variante G:

HPR250GØ35.350+1-1ML2G-CU134

 Diametro utensile speciale d₁ = 35,350 +1 µm -1 µm

Misure in mm.

Supporto per testina intercambiabile HFS da pagina 460.

Per i parametri di lavorazione consigliati, vedere la fine del capitolo.

Alesatore a testina intercambiabile HPR

Versione con regolazione fine, scanalatura dritta, per foro cieco
HPR250

Versione:

Diametro alesatore:

16,600 - 65,000 mm

Imbocco:

ML2G

Materiale da taglio:

HP421

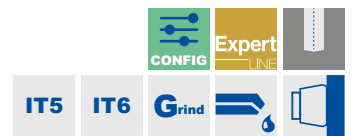
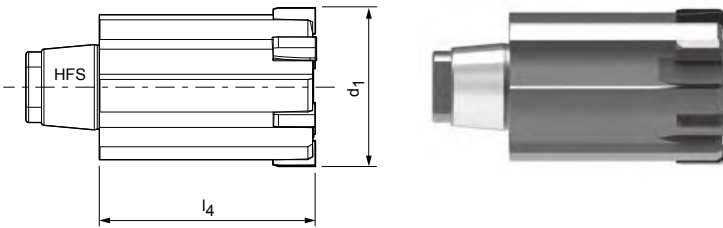
 metallo duro rivestito
in PVD

Caratteristiche configurabili

Diametro del foro tolleranza IT5/IT6:

- Diametro a libera scelta a passi da 0,001 mm
- Ordinabile in funzione del range di diametro a partire da tolleranze IT5/IT6
- > 030,000 IT5 | ≤ 030,000 IT6

Specifiche:

HPR250Ø[diametro][tolleranza]ML2G-HP421

Diametro del foro tolleranza < IT5/IT6:

- Tolleranze inferiori a IT5/IT6 ordinabili come diametro utensile speciale (per variante G vedere pagina 373)

Specifiche variante G:

HPR250GØ[diametro][tolleranza]ML2G-HP421

Dimensioni serie configurabile IT5/IT6

d ₁	l ₄	l ₅	Dimensione HFS	z	Tolleranza
16,600 - 21,290	25	-	10	6	IT6
21,300 - 24,990	27	-	12	6	IT6
25,000 - 28,590	35	-	14	6	IT6
29,000 - 32,290	35	-	16	6	IT5
32,300 - 36,990	41	-	16	6	IT5
37,000 - 41,190	41	-	20	8	IT5
41,200 - 44,900	47	-	20	8	IT5
45,000 - 65,000	47	-	24	8	IT5

Esempio tolleranza IT5:

HPR250Ø35.350H5ML2G-HP421

 Diametro del foro d₁ = 35,350 H5

Esempio variante G:

HPR250GØ35.350+1-1ML2G-HP421

 Diametro utensile speciale d₁ = 35,350 +1 µm -1 µm

Misure in mm.

Supporto per testina intercambiabile HFS da pagina 460.

Per i parametri di lavorazione consigliati, vedere la fine del capitolo.

Alesatore a testina intercambiabile HPR

Versione con regolazione fine, scanalatura dritta, per foro cieco
HPR250

Versione:

Diametro alesatore:

16,600 - 65,000 mm

Imbocco:

M02G

Materiale da taglio:

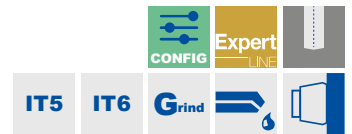
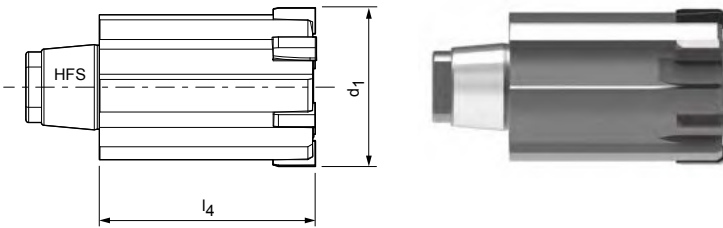
 metallo duro rivestito
in PVD

Caratteristiche configurabili

Diametro del foro tolleranza IT5/IT6:

- Diametro a libera scelta a passi da 0,001 mm
- Ordinabile in funzione del range di diametro a partire da tolleranze IT5/IT6
- > 030,000 IT5 | ≤ 030,000 IT6

Specifiche:

HPR250Ø[diametro][tolleranza]M02G-HP421

Diametro del foro tolleranza < IT5/IT6:

- Tolleranze inferiori a IT5/IT6 ordinabili come diametro utensile speciale (per variante G vedere pagina 373)

Specifiche variante G:

HPR250GØ[diametro][tolleranza]M02G-HP421

Dimensioni serie configurabile IT5/IT6

d ₁	l ₄	l ₅	Dimensione HFS	z	Tolleranza
16,600 - 21,290	25	-	10	6	IT6
21,300 - 24,990	27	-	12	6	IT6
25,000 - 28,590	35	-	14	6	IT6
29,000 - 32,290	35	-	16	6	IT5
32,300 - 36,990	41	-	16	6	IT5
37,000 - 41,190	41	-	20	8	IT5
41,200 - 44,900	47	-	20	8	IT5
45,000 - 65,000	47	-	24	8	IT5

Esempio tolleranza IT5:

HPR250Ø35.350H5M02G-HP421

 Diametro del foro d₁ = 35,350 H5

Esempio variante G:

HPR250GØ35.350+1-1M02G-HP421

 Diametro utensile speciale d₁ = 35,350 +1 µm -1 µm

Alesatore a testina intercambiabile HPR

Versione con regolazione fine, scanalatura dritta, per foro cieco
HPR250

Versione:

Diametro alesatore:

16,600 - 65,000 mm

Imbocco:

MC1G

Materiale da taglio:

CP134

Cermet rivestito in

PVD

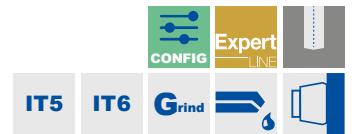
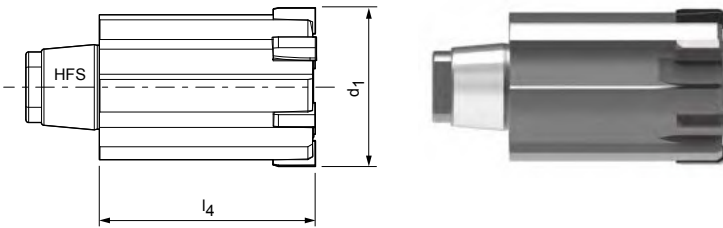

Caratteristiche configurabili



Diametro del foro tolleranza IT5/IT6:

- Diametro a libera scelta a passi da 0,001 mm
- Ordinabile in funzione del range di diametro a partire da tolleranze IT5/IT6
- > 030,000 IT5 | ≤ 030,000 IT6

Specifiche:

HPR250Ø[diametro][tolleranza]MC1G-CP134

Diametro del foro tolleranza < IT5/IT6:

- Tolleranze inferiori a IT5/IT6 ordinabili come diametro utensile speciale (per variante G vedere pagina 373)

Specifiche variante G:

HPR250GØ[diametro][tolleranza]MC1G-CP134

Dimensioni serie configurabile IT5/IT6

d ₁	l ₄	l ₅	Dimensione HFS	z	Tolleranza
16,600 - 21,290	25	-	10	6	IT6
21,300 - 24,990	27	-	12	6	IT6
25,000 - 28,590	35	-	14	6	IT6
29,000 - 32,290	35	-	16	6	IT5
32,300 - 36,990	41	-	16	6	IT5
37,000 - 41,190	41	-	20	8	IT5
41,200 - 44,900	47	-	20	8	IT5
45,000 - 65,000	47	-	24	8	IT5

Esempio tolleranza IT5:

HPR250Ø35.350H5MC1G-CP134

Diametro del foro d₁ = 35,350 H5

Esempio variante G:

HPR250GØ35.350+1-1MC1G-CP134

Diametro utensile speciale d₁ = 35,350 +1 µm -1 µm

Misure in mm.

* per superfici R_a < 2 µm

Supporto per testina intercambiabile HFS da pagina 460.

Per i parametri di lavorazione consigliati, vedere la fine del capitolo.

Alesatore a testina intercambiabile HPR

Versione con regolazione fine, scanalatura dritta, per foro cieco
HPR250

Versione:

Diametro alesatore:

16,600 - 65,000 mm

Imbocco:

MC1G

Materiale da taglio:

HP421

metallo duro rivestito

in PVD

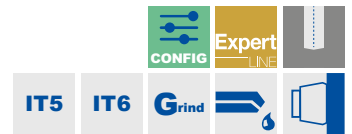
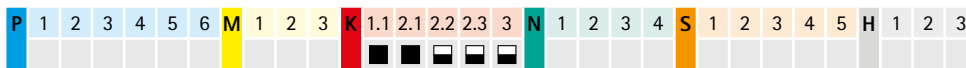
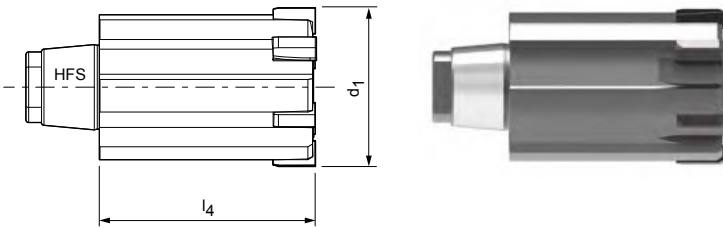

Caratteristiche configurabili



Diametro del foro tolleranza IT5/IT6:

- Diametro a libera scelta a passi da 0,001 mm
- Ordinabile in funzione del range di diametro a partire da tolleranze IT5/IT6
- > 030,000 IT5 | ≤ 030,000 IT6

Specifiche:

HPR250Ø[diametro][tolleranza]MC1G-HP421

Diametro del foro tolleranza < IT5/IT6:

- Tolleranze inferiori a IT5/IT6 ordinabili come diametro utensile speciale (per variante G vedere pagina 373)

Specifiche variante G:

HPR250GØ[diametro][tolleranza]MC1G-HP421

Dimensioni serie configurabile IT5/IT6

d ₁	l ₄	l ₅	Dimensione HFS	z	Tolleranza
16,600 - 21,290	25	-	10	6	IT6
21,300 - 24,990	27	-	12	6	IT6
25,000 - 28,590	35	-	14	6	IT6
29,000 - 32,290	35	-	16	6	IT5
32,300 - 36,990	41	-	16	6	IT5
37,000 - 41,190	41	-	20	8	IT5
41,200 - 44,900	47	-	20	8	IT5
45,000 - 65,000	47	-	24	8	IT5

Esempio tolleranza IT5:

HPR250Ø35.350H5MC1G-HP421

 Diametro del foro d₁ = 35,350 H5

Esempio variante G:

HPR250GØ35.350+1-1MC1G-HP421

 Diametro utensile speciale d₁ = 35,350 +1 µm -1 µm

Misure in mm.

Supporto per testina intercambiabile HFS da pagina 460.

Per i parametri di lavorazione consigliati, vedere la fine del capitolo.

Alesatore a testina intercambiabile HPR

Versione con regolazione fine, scanalatura dritta, per foro cieco
HPR250

Versione:

Diametro alesatore:

16,600 - 65,000 mm

Imbocco:

MC1G

Materiale da taglio:

metallo duro rivestito

in PVD

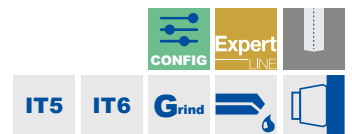
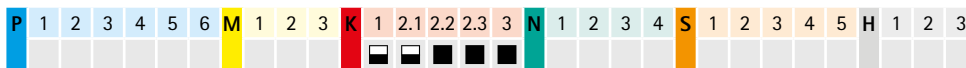
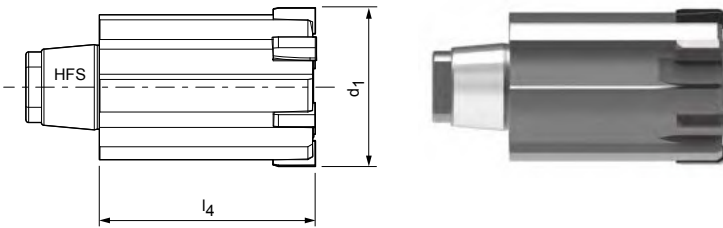

Caratteristiche configurabili

Diametro del foro tolleranza IT5/IT6:

- Diametro a libera scelta a passi da 0,001 mm
- Ordinabile in funzione del range di diametro a partire da tolleranze IT5/IT6
- > 030,000 IT5 | ≤ 030,000 IT6

Specifiche:

HPR250Ø[diametro][tolleranza]MC1G-HP423

Diametro del foro tolleranza < IT5/IT6:

- Tolleranze inferiori a IT5/IT6 ordinabili come diametro utensile speciale (per variante G vedere pagina 373)

Specifiche variante G:

HPR250GØ[diametro][tolleranza]MC1G-HP423

Dimensioni serie configurabile IT5/IT6

d ₁	l ₄	l ₅	Dimensione HFS	z	Tolleranza
16,600 - 21,290	25	-	10	6	IT6
21,300 - 24,990	27	-	12	6	IT6
25,000 - 28,590	35	-	14	6	IT6
29,000 - 32,290	35	-	16	6	IT5
32,300 - 36,990	41	-	16	6	IT5
37,000 - 41,190	41	-	20	8	IT5
41,200 - 44,900	47	-	20	8	IT5
45,000 - 65,000	47	-	24	8	IT5

Esempio tolleranza IT5:

HPR250Ø35.350H5MC1G-HP423

 Diametro del foro d₁ = 35,350 H5

Esempio variante G:

HPR250GØ35.350+1-1MC1G-HP423

 Diametro utensile speciale d₁ = 35,350 +1 µm -1 µm

Misure in mm.

Supporto per testina intercambiabile HFS da pagina 460.

Per i parametri di lavorazione consigliati, vedere la fine del capitolo.

Alesatore a testina intercambiabile HPR

Versione con regolazione fine, scanalatura dritta, per foro cieco
HPR250

Versione:

Diametro alesatore:

16,600 - 65,000 mm

Imbocco:

MA0A

Materiale da taglio:

PU620

Con riporto in PCD

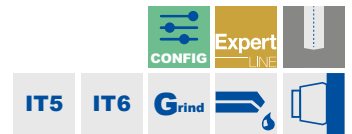
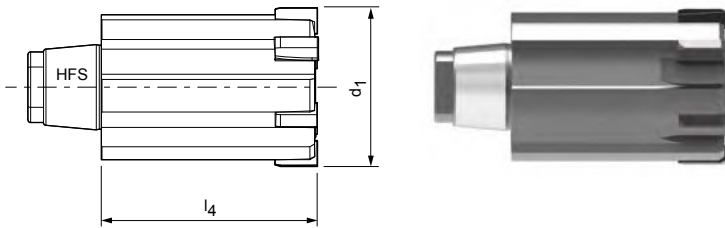

Caratteristiche configurabili



Diametro del foro tolleranza IT5/IT6:

- Diametro a libera scelta a passi da 0,001 mm
- Ordinabile in funzione del range di diametro a partire da tolleranze IT5/IT6
- > 030,000 IT5 | ≤ 030,000 IT6

Specifiche:

HPR250Ø[diametro][tolleranza]MA0A-PU620

Diametro del foro tolleranza < IT5/IT6:

- Tolleranze inferiori a IT5/IT6 ordinabili come diametro utensile speciale (per variante G vedere pagina 373)

Specifiche variante G:

HPR250GØ[diametro][tolleranza]MA0A-PU620

Dimensioni serie configurabile IT5/IT6

d ₁	l ₄	l ₅	Dimensione HFS	z	Tolleranza
16,600 - 21,290	25	-	10	6	IT6
21,300 - 24,990	27	-	12	6	IT6
25,000 - 28,590	35	-	14	6	IT6
29,000 - 32,290	35	-	16	6	IT5
32,300 - 36,990	41	-	16	6	IT5
37,000 - 41,190	41	-	20	8	IT5
41,200 - 44,900	47	-	20	8	IT5
45,000 - 65,000	47	-	24	8	IT5

Esempio tolleranza IT5:

HPR250Ø35.350H5MA0A-PU620

Diametro del foro d₁ = 35,350 H5

Esempio variante G:

HPR250GØ35.350+1-1MA0A-PU620

Diametro utensile speciale d₁ = 35,350 +1 µm -1 µm

Misure in mm.

Supporto per testina intercambiabile HFS da pagina 460.

Per i parametri di lavorazione consigliati, vedere la fine del capitolo.

Alesatore a testina intercambiabile HPR

Versione con regolazione fine, scanalatura dritta, per foro cieco
HPR250

Versione:

Diametro alesatore:

16,600 - 65,000 mm

Imbocco:

M02G

Materiale da taglio:

HP625

metallo duro rivestito
in PVD

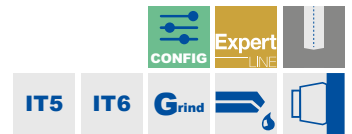
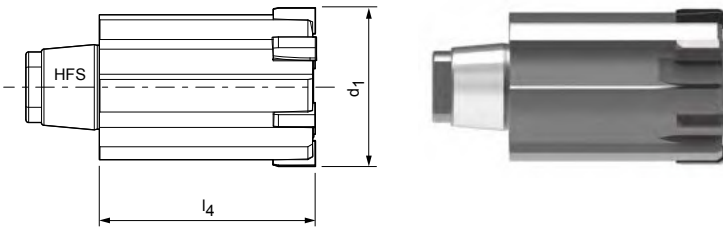

Caratteristiche configurabili



Diametro del foro tolleranza IT5/IT6:

- Diametro a libera scelta a passi da 0,001 mm
- Ordinabile in funzione del range di diametro a partire da tolleranze IT5/IT6
- > 030,000 IT5 | ≤ 030,000 IT6

Specifiche:

HPR250Ø[diametro][tolleranza]M02G-HP625

Diametro del foro tolleranza < IT5/IT6:

- Tolleranze inferiori a IT5/IT6 ordinabili come diametro utensile speciale (per variante G vedere pagina 373)

Specifiche variante G:

HPR250GØ[diametro][tolleranza]M02G-HP625

Dimensioni serie configurabile IT5/IT6

d ₁	l ₄	l ₅	Dimensione HFS	z	Tolleranza
16,600 - 21,290	25	-	10	6	IT6
21,300 - 24,990	27	-	12	6	IT6
25,000 - 28,590	35	-	14	6	IT6
29,000 - 32,290	35	-	16	6	IT5
32,300 - 36,990	41	-	16	6	IT5
37,000 - 41,190	41	-	20	8	IT5
41,200 - 44,900	47	-	20	8	IT5
45,000 - 65,000	47	-	24	8	IT5

Esempio tolleranza IT5:

HPR250Ø35.350H5M02G-HP625

Diametro del foro d₁ = 35,350 H5

Esempio variante G:

HPR250GØ35.350+1-1M02G-HP625

Diametro utensile speciale d₁ = 35,350 +1 µm -1 µm

Misure in mm.

Supporto per testina intercambiabile HFS da pagina 460.

Per i parametri di lavorazione consigliati, vedere la fine del capitolo.

Parametri di lavorazione consigliati per alesatori a testina intercambiabile HPR

Avanzamento e velocità di taglio

HPR131 | HPR231 | HPR180 | HPR280

Materiale da taglio: HP421 | Imbocco: ME1G | ML2G

GTM*	Materiale	Resistenza/durezza [N/mm ²] [HRC]	Velocità di taglio v _c (m/min)			Avanzamento f _z (mm/z) con diametro utensile		
			Adduzione interna del refrigerante	Raffred- damento esterno	MQL	z 4	z 6	
						7,000 - 9,590	9,600 - 21,290	
P	P3.1	Acciai per utensili, per cuscinetti volventi, armonici e per lavorazioni veloci**	< 800					
	P3.2	Acciai per utensili, per cuscinetti volventi, armonici e per lavorazioni veloci**	< 1000	100	100	120	0,100	0,200
	P3.3	Acciai per utensili, per cuscinetti volventi, armonici e per lavorazioni veloci**	< 1500	100	100	120	0,100	0,200
	P5.1	Acciaio fuso		35	35	35	0,070	0,070

HPR150 | HPR250

Materiale da taglio: CU134 | Imbocco: ML2G

GTM*	Materiale	Resistenza/durezza [N/mm ²] [HRC]	Velocità di taglio v _c (m/min)			Avanzamento f _z (mm/z) con diametro utensile		
			Adduzione interna del refrigerante	Raffred- damento esterno	MQL	z 6	z 8	
						16,600 - 36,990	37,000 - 65,000	
P1	P1.1	Acciai da costruzione, automatici, da cementazione e da bonifica, non legati	< 700	140	100	120	0,200	0,250
	P1.2	Acciai da costruzione, automatici, da cementazione e da bonifica, non legati	< 1200	140	100	120	0,200	0,250
P2	P2.1	Acciai da nitrurazione, da cementazione e da bonifica, legati	< 900	140	100	120	0,200	0,250
	P2.2	Acciai da nitrurazione, da cementazione e da bonifica, legati	< 1400	140	100	120	0,200	0,250
P3	P3.1	Acciai per utensili, per cuscinetti volventi, armonici e per lavorazioni veloci**	< 800	140	100	120	0,200	0,250
	P3.2	Acciai per utensili, per cuscinetti volventi, armonici e per lavorazioni veloci**	< 1000					
	P3.3	Acciai per utensili, per cuscinetti volventi, armonici e per lavorazioni veloci**	< 1500					

HPR180 | HPR280

Materiale da taglio: CU134 | Imbocco: ML2G

GTM*	Materiale	Resistenza/durezza [N/mm ²] [HRC]	Velocità di taglio v _c (m/min)			Avanzamento f _z (mm/z) con diametro utensile		
			Adduzione interna del refrigerante	Raffred- damento esterno	MQL	z 4	z 6	
						7,000 - 14,590	14,600 - 21,290	
P1	P1.1	Acciai da costruzione, automatici, da cementazione e da bonifica, non legati	< 700	140	100	120	0,150	0,200
	P1.2	Acciai da costruzione, automatici, da cementazione e da bonifica, non legati	< 1200	140	100	120	0,150	0,200
P2	P2.1	Acciai da nitrurazione, da cementazione e da bonifica, legati	< 900	140	100	120	0,150	0,200
	P2.2	Acciai da nitrurazione, da cementazione e da bonifica, legati	< 1400	140	100	120	0,150	0,200
P3	P3.1	Acciai per utensili, per cuscinetti volventi, armonici e per lavorazioni veloci**	< 800	140	100	120	0,150	0,200
	P3.2	Acciai per utensili, per cuscinetti volventi, armonici e per lavorazioni veloci**	< 1000					
	P3.3	Acciai per utensili, per cuscinetti volventi, armonici e per lavorazioni veloci**	< 1500					

* Gruppi di materiale MAPAL

** Qualora la somma dei componenti di lega Cr, Mo, Ni, V, W equivalesse a > 8%, selezionare il gruppo di materiale MAPAL immediatamente superiore.

HPR110 | HPR210 | HPR150 | HPR250

Materiale da taglio: HP421 | Imbocco: ME1G | ML2G

GTM*	Materiale	Resistenza/durezza [N/mm ²] [HRC]	Velocità di taglio v _c (m/min)			Avanzamento f _z (mm/z) con diametro utensile		
			Adduzione interna del refrigerante	Raffred- damento esterno	MQL	z 6	z 8	
						15,600 - 29,990	30,00 - 65,00	
P	P3.1	Acciai per utensili, per cuscinetti volventi, armonici e per lavorazioni veloci**	< 800	120	100	120	0,200	0,200
	P3.2	Acciai per utensili, per cuscinetti volventi, armonici e per lavorazioni veloci**	< 1000	100	100	120	0,200	0,200
	P3.3	Acciai per utensili, per cuscinetti volventi, armonici e per lavorazioni veloci**	< 1500	100	100	120	0,200	0,200
	P5.1	Acciaio fuso		35	35	35	0,070	0,070

HPR110 | HPR210

Materiale da taglio: CU134 | Imbocco: ME1G

GTM*	Materiale	Resistenza/durezza [N/mm ²] [HRC]	Velocità di taglio v _c (m/min)			Avanzamento f _z (mm/z) con diametro utensile		
			Adduzione interna del refrigerante	Raffred- damento esterno	MQL	z 6	z 8	
						15,600 - 29,990	30,000 - 65,000	
P1	P1.1	Acciai da costruzione, automatici, da cementazione e da bonifica, non legati	< 700	140	100	120	0,200	0,250
	P1.2	Acciai da costruzione, automatici, da cementazione e da bonifica, non legati	< 1200	140	100	120	0,200	0,250
P2	P2.1	Acciai da nitrurazione, da cementazione e da bonifica, legati	< 900	140	100	120	0,200	0,250
	P2.2	Acciai da nitrurazione, da cementazione e da bonifica, legati	< 1400	140	100	120	0,200	0,250
P3	P3.1	Acciai per utensili, per cuscinetti volventi, armonici e per lavorazioni veloci**	< 800	140	100	120	0,200	0,250
	P3.2	Acciai per utensili, per cuscinetti volventi, armonici e per lavorazioni veloci**	< 1000					
	P3.3	Acciai per utensili, per cuscinetti volventi, armonici e per lavorazioni veloci**	< 1500					

HPR131 | HPR231

Materiale da taglio: CU134 | Imbocco: ME1G

GTM*	Materiale	Resistenza/durezza [N/mm ²] [HRC]	Velocità di taglio v _c (m/min)			Avanzamento f _z (mm/z) con diametro utensile		
			Adduzione interna del refrigerante	Raffred- damento esterno	MQL	z 4	z 6	
						7,000 - 9,590	9,600 - 18,590	
P1	P1.1	Acciai da costruzione, automatici, da cementazione e da bonifica, non legati	< 700	140	100	120	0,150	0,200
	P1.2	Acciai da costruzione, automatici, da cementazione e da bonifica, non legati	< 1200	140	100	120	0,150	0,200
P2	P2.1	Acciai da nitrurazione, da cementazione e da bonifica, legati	< 900	140	100	120	0,150	0,200
	P2.2	Acciai da nitrurazione, da cementazione e da bonifica, legati	< 1400	140	100	120	0,150	0,200
P3	P3.1	Acciai per utensili, per cuscinetti volventi, armonici e per lavorazioni veloci**	< 800	140	100	120	0,150	0,200
	P3.2	Acciai per utensili, per cuscinetti volventi, armonici e per lavorazioni veloci**	< 1000					
	P3.3	Acciai per utensili, per cuscinetti volventi, armonici e per lavorazioni veloci**	< 1500					

I parametri di lavorazione indicati sono valori orientativi.

I dati ottimali per la specifica applicazione devono essere rilevati eseguendo diversi tentativi o durante l'effettiva lavorazione.

Parametri di lavorazione consigliati per alesatori a testina intercambiabile HPR

Avanzamento e velocità di taglio

HPR131 | HPR231 | HPR180 | HPR280

Materiale da taglio: HP421 | Imbocco: MF1G | M02G

GTM*	Materiale		Resistenza/durezza [N/mm ²] [HRC]	Velocità di taglio v _c (m/min)		
				Adduzione interna del refrigerante	Raffreddamento esterno	MQL
P	P4	P4.1	Acciai inossidabili, ferritici e martensitici	35	35	35
	P6	P6.1	Acciaio fuso, ferritico e martensitico	35	35	35
M	M1	M1.1	Acciai inossidabili, austenitici	< 700	35	35
		M1.2	Acciai inossidabili, ferritici/austenitici (Duplex)	< 1000	35	35
	M2	M2.1	Acciaio fuso inossidabile, austenitico	< 700	35	35
	M3	M3.1	Acciaio fuso inossidabile, ferritico/austenitico (Duplex)	< 1000	35	35

HPR110 | HPR210 | HPR150 | HPR250

Materiale da taglio: HP421 | Imbocco: MF1G | M02G

GTM*	Materiale		Resistenza/durezza [N/mm ²] [HRC]	Velocità di taglio v _c (m/min)		
				Adduzione interna del refrigerante	Raffreddamento esterno	MQL
P	P4	P4.1	Acciai inossidabili, ferritici e martensitici	35	35	35
	P6	P6.1	Acciaio fuso, ferritico e martensitico	35	35	35
M	M1	M1.1	Acciai inossidabili, austenitici	< 700	35	35
		M1.2	Acciai inossidabili, ferritici/austenitici (Duplex)	< 1000	35	35
	M2	M2.1	Acciaio fuso inossidabile, austenitico	< 700	35	35
	M3	M3.1	Acciaio fuso inossidabile, ferritico/austenitico (Duplex)	< 1000	35	35

Avanzamento f_z (mm/z) con diametro utensile			
HPR131 HPR231		HPR180 HPR280	
z4	z6	z4	z6
7,000-9,590	9,600-18,590	7,000-14,590	14,600-21,290
0,070	0,070	0,070	0,070
0,070	0,070	0,070	0,070
0,070	0,070	0,070	0,070
0,070	0,070	0,070	0,070
0,070	0,070	0,070	0,070
0,070	0,070	0,070	0,070

Avanzamento f_z (mm/z) con diametro utensile			
HPR110 HPR210		HPR150 HPR250	
z6	z8	z6	z8
15,600-29,990	30,000-65,000	16,600-36,990	37,000-65,000
0,070	0,070	0,070	0,070
0,070	0,070	0,070	0,070
0,070	0,070	0,070	0,070
0,070	0,070	0,070	0,070
0,070	0,070	0,070	0,070
0,070	0,070	0,070	0,070

I parametri di lavorazione indicati sono valori orientativi.

I dati ottimali per la specifica applicazione devono essere rilevati eseguendo diversi tentativi o durante l'effettiva lavorazione.

Parametri di lavorazione consigliati per alesatori a testina intercambiabile HPR

Avanzamento e velocità di taglio

HPR130 | HPR230 | HPR180 | HPR280

Materiale da taglio: HP423 | Imbocco: MC1G

GTM*	Materiale	Resistenza/durezza [N/mm ²] [HRC]	Velocità di taglio v _c (m/min)				
			Adduzione interna del refrigerante	Raffreddamento esterno	MQL		
K	K1	K1.1	Ghisa con grafite lamellare (ghisa grigia), GJL	< 300	140	100	120
		K2.1	Ghisa con grafite sferoidale, GJS	< 500	140	100	120
	K2	K2.2	Ghisa con grafite sferoidale, GJS	≤ 800			
		K2.3	Ghisa con grafite sferoidale, GJS	> 800			

HPR100 | HPR200 | HPR150 | HPR250

Materiale da taglio: CP134 | Imbocco: MC1G

GTM*	Materiale	Resistenza/durezza [N/mm ²] [HRC]	Velocità di taglio v _c (m/min)				
			Adduzione interna del refrigerante	Raffreddamento esterno	MQL		
K	K1	K1.1	Ghisa con grafite lamellare (ghisa grigia), GJL	< 300	140	100	120
		K2.1	Ghisa con grafite sferoidale, GJS	< 500	140	100	120
	K2	K2.2	Ghisa con grafite sferoidale, GJS	≤ 800			
		K2.3	Ghisa con grafite sferoidale, GJS	> 800			

HPR130 | HPR180

Materiale da taglio: HC419 | Imbocco: MC1G

GTM*	Materiale	Resistenza/durezza [N/mm ²] [HRC]	Velocità di taglio v _c (m/min)				
			Adduzione interna del refrigerante	Raffreddamento esterno	MQL		
K	K1	K1.1	Ghisa con grafite lamellare (ghisa grigia), GJL	< 300	120	100	120

HPR100 | HPR150

Materiale da taglio: HC419 | Imbocco: MC1G

GTM*	Materiale	Resistenza/durezza [N/mm ²] [HRC]	Velocità di taglio v _c (m/min)				
			Adduzione interna del refrigerante	Raffreddamento esterno	MQL		
K	K1	K1.1	Ghisa con grafite lamellare (ghisa grigia), GJL	< 300	120	100	120

Avanzamento f_z (mm/z) con diametro utensile			
HPR130 HPR230		HPR180 HPR280	
z4	z6	z4	z6
7,000-9,590	9,600-18,590	7,000-14,590	14,600-21,290
0,150	0,200	0,150	0,200
0,150	0,200	0,150	0,200

Avanzamento f_z (mm/z) con diametro utensile			
HPR100 HPR200		HPR150 HPR250	
z6	z8	z6	z8
15,600-29,990	30,000-65,000	16,600-36,990	37,000-65,000
0,200	0,300	0,200	0,300
0,200	0,300	0,200	0,300

Avanzamento f_z (mm/z) con diametro utensile			
HPR130		HPR180	
z 4	z 6	z 4	z 6
7,000-9,590	9,600-18,590	7,000-14,590	14,600-21,290
0,150	0,200	0,150	0,200

Avanzamento f_z (mm/z) con diametro utensile			
HPR100		HPR150	
z6	z8	z6	z8
15,600-29,990	30,000-65,000	16,600-36,990	37,000-65,000
0,150	0,200	0,150	0,200

I parametri di lavorazione indicati sono valori orientativi.

I dati ottimali per la specifica applicazione devono essere rilevati eseguendo diversi tentativi o durante l'effettiva lavorazione.

Parametri di lavorazione consigliati per alesatori a testina intercambiabile HPR

Avanzamento e velocità di taglio

HPR130 | HPR230 | HPR180 | HPR280

Materiale da taglio: HP421 | Imbocco: MC1G

GTM*	Materiale	Resistenza/durezza [N/mm ²] [HRC]	Velocità di taglio v _c (m/min)			
			Adduzione interna del refrigerante	Raffreddamento esterno	MQL	
K2	K2.1	Ghisa con grafite sferoidale, GJS	< 500	120	100	120
	K2.2	Ghisa con grafite sferoidale, GJS	≤ 800			
	K2.3	Ghisa con grafite sferoidale, GJS	> 800			

HPR100 | HPR200 | HPR150 | HPR250

Materiale da taglio: HP421 | Imbocco: MC1G

GTM*	Materiale	Resistenza/durezza [N/mm ²] [HRC]	Velocità di taglio v _c (m/min)			
			Adduzione interna del refrigerante	Raffreddamento esterno	MQL	
K2	K2.1	Ghisa con grafite sferoidale, GJS	< 500	120	100	120
	K2.2	Ghisa con grafite sferoidale, GJS	≤ 800			
	K2.3	Ghisa con grafite sferoidale, GJS	> 800			

HPR130 | HPR230 | HPR180 | HPR280

Materiale da taglio: HP423 | Imbocco: MC1G

GTM*	Materiale	Resistenza/durezza [N/mm ²] [HRC]	Velocità di taglio v _c (m/min)				
			Adduzione interna del refrigerante	Raffreddamento esterno	MQL		
K	K2	K2.1	Ghisa con grafite sferoidale, GJS	< 500			
		K2.2	Ghisa con grafite sferoidale, GJS	≤ 800	120	100	120
		K2.3	Ghisa con grafite sferoidale, GJS	> 800	120	100	120
	K3	K3.1	Ghisa con grafite vermicolare, GJV; acciaio fuso malleabile, GJM	< 500	90	70	90
		K3.2	Ghisa con grafite vermicolare, GJV; acciaio fuso malleabile, GJM	> 500	90	70	90

HPR100 | HPR200 | HPR150 | HPR250

Materiale da taglio: HP423 | Imbocco: MC1G

GTM*	Materiale	Resistenza/durezza [N/mm ²] [HRC]	Velocità di taglio v _c (m/min)				
			Adduzione interna del refrigerante	Raffreddamento esterno	MQL		
K	K2	K2.1	Ghisa con grafite sferoidale, GJS	< 500			
		K2.2	Ghisa con grafite sferoidale, GJS	≤ 800	120	100	120
		K2.3	Ghisa con grafite sferoidale, GJS	> 800	120	100	120
	K3	K3.1	Ghisa con grafite vermicolare, GJV; acciaio fuso malleabile, GJM	< 500	90	70	90
		K3.2	Ghisa con grafite vermicolare, GJV; acciaio fuso malleabile, GJM	> 500	90	70	90

Avanzamento f_z (mm/z) con diametro utensile			
HPR130 HPR230		HPR180 HPR280	
z4	z6	z4	z6
7,000-9,590	9,600-18,590	7,000-14,590	14,600-21,290
0,150	0,200	0,150	0,200

Avanzamento f_z (mm/z) con diametro utensile			
HPR100 HPR200		HPR150 HPR250	
z6	z8	z6	z8
15,600-29,990	30,000-65,000	16,600-36,990	37,000-65,000
0,150	0,200	0,150	0,200

Avanzamento f_z (mm/z) con diametro utensile			
HPR130 HPR230		HPR180 HPR280	
z4	z6	z4	z6
7,000-9,590	9,600-18,590	7,000-14,590	14,600-21,290
0,150	0,200	0,150	0,200
0,150	0,200	0,150	0,200
0,150	0,200	0,150	0,200
0,150	0,200	0,150	0,200

Avanzamento f_z (mm/z) con diametro utensile			
HPR100 HPR200		HPR150 HPR250	
z6	z8	z6	z8
15,600-29,990	30,000-65,000	16,600-36,990	37,000-65,000
0,150	0,200	0,150	0,200
0,150	0,200	0,150	0,200
0,150	0,200	0,150	0,200
0,150	0,200	0,150	0,200

I parametri di lavorazione indicati sono valori orientativi.

I dati ottimali per la specifica applicazione devono essere rilevati eseguendo diversi tentativi o durante l'effettiva lavorazione.

Parametri di lavorazione consigliati per alesatori a testina intercambiabile HPR

Avanzamento e velocità di taglio

HPR130 | HPR230 | HPR180 | HPR280

Materiale da taglio: PU620 | Imbocco: MA0A

GTM*	Materiale	Resistenza/durezza [N/mm ²] [HRC]	Velocità di taglio v _c (m/min)			
			Adduzione interna del refrigerante	Raffreddamento esterno	MQL	
N	N1	N1.1 Alluminio, non legato e legato < 3% Si	130	100	120	
		N1.2 Alluminio, legato ≤ 7% Si	130	100	120	
		N1.3 Alluminio, legato > 7 - 12% Si	130	100	120	
		N1.4 Alluminio, legato > 12% Si	130	100	120	
	N2	N2.1 Rame, non legato e bassolegato	< 300	130	100	120
		N2.2 Rame, legato	> 300	130	100	120
		N2.3 Ottone, bronzo, ghisa rossa	< 1200	130	100	120

HPR100 | HPR200 | HPR150 | HPR250

Materiale da taglio: PU620 | Imbocco: MA0A

GTM*	Materiale	Resistenza/durezza [N/mm ²] [HRC]	Velocità di taglio v _c (m/min)			
			Adduzione interna del refrigerante	Raffreddamento esterno	MQL	
N	N1	N1.1 Alluminio, non legato e legato < 3% Si	130	100	120	
		N1.2 Alluminio, legato ≤ 7% Si	130	100	120	
		N1.3 Alluminio, legato > 7-12% Si	130	100	120	
		N1.4 Alluminio, legato > 12% Si	130	100	120	
	N2	N2.1 Rame, non legato e bassolegato	< 300	130	100	120
		N2.2 Rame, legato	> 300	130	100	120
		N2.3 Ottone, bronzo, ghisa rossa	< 1200	130	100	120

Avanzamento f_z (mm/z) con diametro utensile			
HPR130 HPR230		HPR180 HPR280	
z4	z6	z4	z6
7,000-9,590	9,600-18,590	7,000-14,590	14,600-21,290
0,150	0,250	0,150	0,250
0,150	0,250	0,150	0,250
0,150	0,250	0,150	0,250
0,150	0,250	0,150	0,250
0,150	0,250	0,150	0,250
0,150	0,250	0,150	0,250
0,150	0,250	0,150	0,250

Avanzamento f_z (mm/z) con diametro utensile			
HPR100 HPR200		HPR150 HPR250	
z6	z8	z6	z8
15,600-29,990	30,000-65,000	16,600-36,990	37,000-65,000
0,150	0,250	0,150	0,250
0,150	0,250	0,150	0,250
0,150	0,250	0,150	0,250
0,150	0,250	0,150	0,250
0,150	0,250	0,150	0,250
0,150	0,250	0,150	0,250
0,150	0,250	0,150	0,250

I parametri di lavorazione indicati sono valori orientativi.

I dati ottimali per la specifica applicazione devono essere rilevati eseguendo diversi tentativi o durante l'effettiva lavorazione.

Parametri di lavorazione consigliati per alesatori a testina intercambiabile HPR

Avanzamento e velocità di taglio

HPR180 | HPR280

Materiale da taglio: HP625 | Imbocco: MO2G

GTM*	Materiale	Resistenza/durezza [N/mm ²] [HRC]	Velocità di taglio v _c (m/min)			Avanzamento f _z (mm/z) con diametro utensile		
			Adduzione interna del refrigerante	Raffred- damento esterno	MQL	z 4	z 6	
						7,000-14,590	14,600-21,290	
S	S1.1	Titanio, leghe di titanio	< 400	35	20	25	0,060	0,080
	S2.1	Titanio, leghe di titanio	< 1200	35	20	25	0,060	0,080
	S2.2	Titanio, leghe di titanio	> 1200	35	20	25	0,060	0,080
	S3.1	Nichel, non legato e legato	< 900	30	15	25	0,060	0,080
	S3.2	Nichel, non legato e legato	> 900	30	15	25	0,060	0,080
	S4.1	Superlega resistente ad alte temperature a base di Ni, Co e Fe		25	15	20	0,060	0,080
	S5.1	Leghe di tungsteno e molibdeno		25	15	20	0,060	0,080

HPR131 | HPR231

Materiale da taglio: HP625 | Imbocco: MF1G

GTM*	Materiale	Resistenza/durezza [N/mm ²] [HRC]	Velocità di taglio v _c (m/min)			Avanzamento f _z (mm/z) con diametro utensile		
			Adduzione interna del refrigerante	Raffred- damento esterno	MQL	z 4	z 6	
						7,000-9,590	9,600-18,590	
S	S1.1	Titanio, leghe di titanio	< 400	35	20	25	0,060	0,100
	S2.1	Titanio, leghe di titanio	< 1200	35	20	25	0,060	0,100
	S2.2	Titanio, leghe di titanio	> 1200	35	20	25	0,060	0,100
	S3.1	Nichel, non legato e legato	< 900	30	15	25	0,060	0,100
	S3.2	Nichel, non legato e legato	> 900	30	15	25	0,060	0,100
	S4.1	Superlega resistente ad alte temperature a base di Ni, Co e Fe		25	15	20	0,060	0,100
	S5.1	Leghe di tungsteno e molibdeno		25	15	20	0,060	0,100

HPR110 | HPR210

Materiale da taglio: HP625 | Imbocco: MF1G

GTM*	Materiale	Resistenza/durezza [N/mm ²] [HRC]	Velocità di taglio v _c (m/min)			Avanzamento f _z (mm/z) con diame- tro utensile			
			Adduzione interna del refrigerante	Raffred- damento esterno	MQL	z 6	z 8		
						15,600-29,990	30,000-65,000		
S	S1.1	Titanio, leghe di titanio	< 400	35	20	25	0,100	0,100	
	S2	S2.1	Titanio, leghe di titanio	< 1200	35	20	25	0,100	0,100
		S2.2	Titanio, leghe di titanio	> 1200	35	20	25	0,100	0,100
	S3	S3.1	Nichel, non legato e legato	< 900	30	15	25	0,100	0,100
		S3.2	Nichel, non legato e legato	> 900	30	15	25	0,100	0,100
	S4	S4.1	Superlega resistente ad alte temperature a base di Ni, Co e Fe		25	15	20	0,100	0,100
	S5	S5.1	Leghe di tungsteno e molibdeno		25	15	20	0,100	0,100

HPR150 | HPR250

Materiale da taglio: HP625 | Imbocco: MO2G

GTM*	Materiale	Resistenza/durezza [N/mm ²] [HRC]	Velocità di taglio v _c (m/min)			Avanzamento f _z (mm/z) con diame- tro utensile			
			Adduzione interna del refrigerante	Raffred- damento esterno	MQL	z 6	z 8		
						16,600-36,990	37,000-65,000		
S	S1.1	Titanio, leghe di titanio	< 400	35	20	25	0,080	0,080	
	S2	S2.1	Titanio, leghe di titanio	< 1200	35	20	25	0,080	0,080
		S2.2	Titanio, leghe di titanio	> 1200	35	20	25	0,080	0,080
	S3	S3.1	Nichel, non legato e legato	< 900	30	15	25	0,080	0,080
		S3.2	Nichel, non legato e legato	> 900	30	15	25	0,080	0,080
	S4	S4.1	Superlega resistente ad alte temperature a base di Ni, Co e Fe		25	15	20	0,080	0,080
	S5	S5.1	Leghe di tungsteno e molibdeno		25	15	20	0,080	0,080

I parametri di lavorazione indicati sono valori orientativi.

I dati ottimali per la specifica applicazione devono essere rilevati eseguendo diversi tentativi o durante l'effettiva lavorazione.

Sovrametallo per alesatura

GTM*		Materiale	Resistenza/durezza [N/mm ²] [HRC]
P	P1	P1.1 Acciai da costruzione, automatici, da cementazione e da bonifica, non legati	< 700
		P1.2 Acciai da costruzione, automatici, da cementazione e da bonifica, non legati	< 1200
	P2	P2.1 Acciai da niturazione, da cementazione e da bonifica, legati	< 900
		P2.2 Acciai da niturazione, da cementazione e da bonifica, legati	< 1400
	P3	P3.1 Acciai per utensili, per cuscinetti volventi, armonici e per lavorazioni veloci**	< 800
		P3.2 Acciai per utensili, per cuscinetti volventi, armonici e per lavorazioni veloci**	< 1000
		P3.3 Acciai per utensili, per cuscinetti volventi, armonici e per lavorazioni veloci**	< 1500
	P4	P4.1 Acciai inossidabili, ferritici e martensitici	
	P5	P5.1 Acciaio fuso	
	P6	P6.1 Acciaio fuso, ferritico e martensitico	
M	M1	M1.1 Acciai inossidabili, austenitici	< 700
		M1.2 Acciai inossidabili, ferritici/austenitici (Duplex)	< 1000
	M2	M2.1 Acciaio fuso inossidabile, austenitico	< 700
	M3	M3.1 Acciaio fuso inossidabile, ferritico/austenitico (Duplex)	< 1000
K	K1	K1.1 Ghisa con grafite lamellare (ghisa grigia), GJL	< 300
		K2.1 Ghisa con grafite sferoidale, GJS	< 500
	K2	K2.2 Ghisa con grafite sferoidale, GJS	≤ 800
		K2.3 Ghisa con grafite sferoidale, GJS	> 800
	K3	K3.1 Ghisa con grafite vermicolare, GJV; acciaio fuso malleabile, GJM	< 500
		K3.2 Ghisa con grafite vermicolare, GJV; acciaio fuso malleabile, GJM	> 500
N	N1	N1.1 Alluminio, non legato e legato < 3% Si	
		N1.2 Alluminio, legato ≤ 7% Si	
		N1.3 Alluminio, legato > 7-12% Si	
		N1.4 Alluminio, legato > 12% Si	
	N2	N2.1 Rame, non legato e bassolegato	< 300
		N2.2 Rame, legato	> 300
		N2.3 Ottone, bronzo, ghisa rossa	< 1200
	N4	N4.1 Plastica, thermoplast	
		N4.2 Plastica, duroplast	
		N4.3 Plastica, materiali espansi	
C	C1	C1.1 Matrice plastica, rinforzata con fibre di amide (AFK)	
		C1.2 Matrice plastica (duroplastica), CFK/GFK	
		C1.3 Matrice plastica (termoplastica), CFK/GFK	
	C2	C2.1 Matrice in carbonio, rinforzata con fibre di carbonio (CFC)	
S	S1	S1.1 Titanio, leghe di titanio	< 400
		S2.1 Titanio, leghe di titanio	< 1200
	S2	S2.2 Titanio, leghe di titanio	> 1200
		S3.1 Nichel, non legato e legato	< 900
	S3	S3.2 Nichel, non legato e legato	> 900
		S4	S4.1 Superlega resistente ad alte temperature a base di Ni, Co e Fe
S5	S5.1 Leghe di tungsteno e molibdeno		
H	H1	H1.1 Acciaio temprato/acciaio fuso	< 44
		H1.2 Acciaio temprato/acciaio fuso	< 55
	H2	H2.1 Acciaio temprato/acciaio fuso	< 60
		H2.2 Acciaio temprato/acciaio fuso	< 65
		H2.3 Acciaio temprato/acciaio fuso	< 68
	H3	H3.1 Ghisa resistente all'usura/ghisa temperata, GJN	

* Gruppi di materiale MAPAL

** Qualora la somma dei componenti di lega Cr, Mo, Ni, V, W equivalesse a > 8%, selezionare il gruppo di materiale MAPAL immediatamente superiore.

	Sovrametallo a_p [mm] per alesatura				
	< Ø5mm	Ø5-8mm	Ø8-12mm	Ø12-18mm	> Ø18 mm
	0,100	0,100	0,150	0,150	0,150
	0,100	0,100	0,100	0,150	0,150
	0,100	0,100	0,150	0,150	0,150
	0,100	0,100	0,100	0,150	0,150
	0,100	0,100	0,150	0,150	0,150
	0,100	0,100	0,150	0,150	0,150
	0,100	0,100	0,100	0,150	0,150
	0,100	0,100	0,100	0,100	0,100
	0,100	0,100	0,100	0,150	0,150
	0,100	0,100	0,100	0,100	0,100
	0,100	0,100	0,100	0,100	0,100
	0,100	0,100	0,100	0,100	0,100
	0,100	0,100	0,100	0,100	0,100
	0,150	0,150	0,150	0,150	0,150
	0,150	0,150	0,150	0,150	0,150
	0,150	0,150	0,150	0,150	0,150
	0,100	0,150	0,150	0,150	0,150
	0,150	0,150	0,150	0,150	0,150
	0,100	0,150	0,150	0,150	0,150
	0,150	0,150	0,150	0,150	0,150
	0,150	0,150	0,150	0,150	0,150
	0,150	0,150	0,150	0,150	0,150
	0,150	0,150	0,150	0,150	0,150
	0,150	0,150	0,150	0,150	0,150
	0,200	0,200	0,200	0,200	0,200
	0,200	0,200	0,200	0,200	0,200
	0,200	0,200	0,200	0,200	0,200
	0,200	0,200	0,200	0,200	0,200
	0,200	0,200	0,200	0,200	0,200
	0,100	0,100	0,100	0,100	0,100
	0,100	0,100	0,100	0,100	0,100
	0,100	0,100	0,100	0,100	0,100
	0,100	0,100	0,100	0,100	0,100
	0,100	0,100	0,100	0,100	0,100
	0,100	0,100	0,100	0,100	0,100
	0,100	0,100	0,100	0,100	0,100
	0,075	0,075	0,075	0,075	0,075
	0,050	0,050	0,075	0,075	0,075
	0,050	0,050	0,075	0,075	0,075
	0,050	0,050	0,075	0,075	0,075
	0,050	0,050	0,075	0,075	0,075
	0,100	0,050	0,075	0,075	0,075

I parametri di lavorazione indicati sono valori orientativi.

I dati ottimali per la specifica applicazione devono essere rilevati eseguendo diversi tentativi o durante l'effettiva lavorazione.

Caratteristiche utensile in dettaglio sistemi HFS



Sistema di serraggio assiale HFS

Disponibile anche per modulo e innesti HSK



1 Diverse varianti di supporti
ad es. codolo cilindrico, HSK-A

2 Cono per un centraggio semplice e molto preciso

3 Superficie di appoggio piana per una maggior rigidità e stabilità

4 Adduzione interna del refrigerante
Uscita direttamente presso il tagliente

5 Vite di serraggio solida ad elevata precisione con filettatura differenziale



Sistema di serraggio radiale HFS

Sostituzione della testina semplice, rapida e di norma nella macchina



6 Perno eccentrico
per un serraggio e un rilascio rapido con elevata forza di bloccaggio

7 Cono per un centraggio semplice e molto preciso

8 Superficie di appoggio piana per una maggior rigidità e stabilità

9 Adduzione interna del refrigerante
Uscita direttamente presso il tagliente

10 Perno di bloccaggio di precisione

11 Diverse varianti di supporti
ad es. codolo cilindrico, HSK-A



Codice di denominazione

Supporto per testina intercambiabile HFS

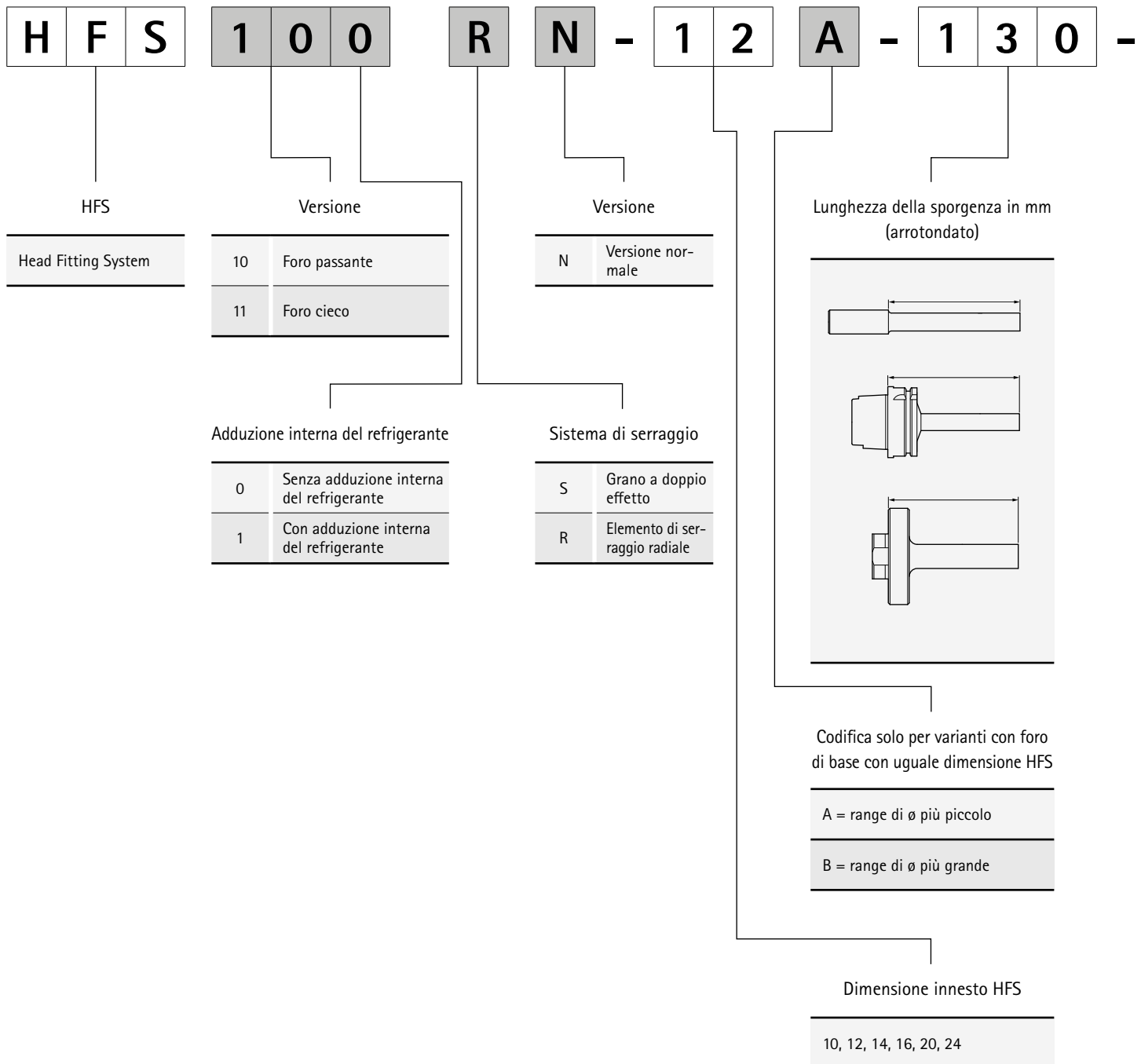

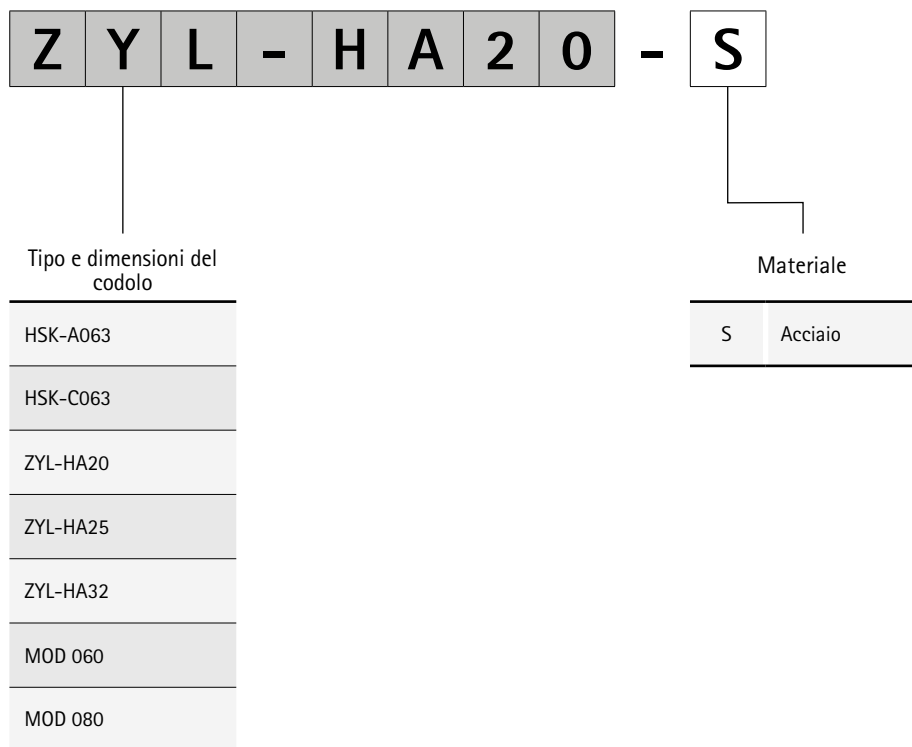

Supporto per testina intercambiabile HFS

Con sistema di serraggio assiale

Codolo secondo MN 623, analogo a DIN 1835-A

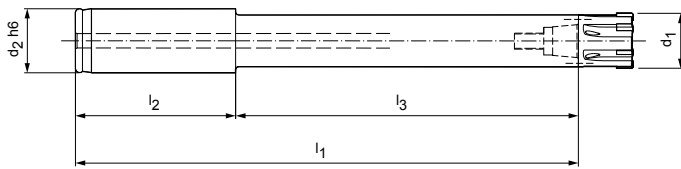

Versione lunga con codolo cilindrico

Dimensioni						Specifiche	Codice
d ₁	Dimensione HFS	d ₂ h6	l ₁	l ₂	l ₃		
15,60 - 18,59	10	20	160	50	110	HFS101SN-10-110-ZYL-HA20-S	30010248
18,60 - 21,29	12	20	179,5	50	129,5	HFS101SN-12-130-ZYL-HA20-S	30010249
21,30 - 23,99	14	20	180,5	50	130,5	HFS101SN-14-131-ZYL-HA20-S	30010250
24,00 - 29,99	16	25	211	60	151	HFS101SN-16-151-ZYL-HA25-S	30010251
30,00 - 39,99	20	25	210	60	150	HFS101SN-20-150-ZYL-HA25-S	30010252
40,00 - 50,70	24	32	266	60	206	HFS101SN-24-206-ZYL-HA32-S	30010253
50,71 - 65,00							

Versione corta con codolo cilindrico

Dimensioni						Specifiche	Codice
d ₁	Dimensione HFS	d ₂ h6	l ₁	l ₂	l ₃		
15,60 - 18,59	10	20	99	50	49	HFS101SN-10-049-ZYL-HA20-S	30010256
18,60 - 21,29	12	20	118,5	50	68,5	HFS101SN-12-069-ZYL-HA20-S	30010257
21,30 - 23,99	14	20	119,5	50	69,5	HFS101SN-14-070-ZYL-HA20-S	30010258
24,00 - 29,99	16	25	150	60	90	HFS101SN-16-090-ZYL-HA25-S	30010259
30,00 - 39,99	20	25	149	60	89	HFS101SN-20-089-ZYL-HA25-S	30010260
40,00 - 50,70	24	32	167	60	107	HFS101SN-24-107-ZYL-HA32-S	30010261
50,71 - 65,00							

Versione ultra-corta con codolo cilindrico

Dimensioni						Specifiche	Codice
d ₁	Dimensione HFS	d ₂ h6	l ₁	l ₂	l ₃		
18,60 - 21,29	12	20	82	50	32	HFS101SN-12-032-ZYL-HA20-S	30078683

Misure in mm.

Fornitura: Supporto con grano a doppio effetto e cacciavite con impugnatura a T.

Supporto per testina intercambiabile HFS

Con sistema di serraggio assiale

Codolo secondo MN 623, analogo a DIN 1835-A

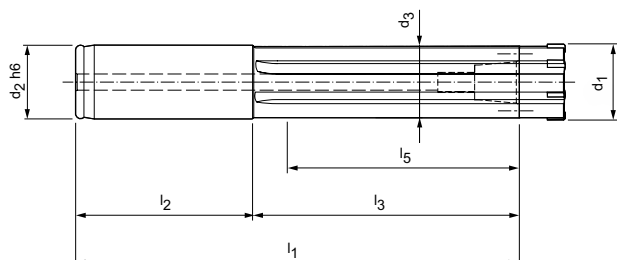

Versione lunga con codolo cilindrico

Dimensioni								Specifiche	Codice
d ₁	Dimensione HFS	d ₂ h6	d ₃	l ₁	l ₂	l ₃	l ₅		
16,60 - 19,39	10	20	16	160	50	110	94	HFS111SN-10A-110-ZYL-HA20-S	30026380
19,40 - 21,29	10	20	18,6	160	50	110	94	HFS111SN-10B-110-ZYL-HA20-S	30026488
21,30 - 24,99	12	20	20,5	180,5	50	130,5	114,5	HFS111SN-12-131-ZYL-HA20-S	30026489
25,00 - 28,99	14	25	24,2	211,5	60	151,5	132,5	HFS111SN-14-152-ZYL-HA25-S	30026510
29,00 - 32,29	16	25	28,2	210	60	150	131	HFS111SN-16A-150-ZYL-HA25-S	30026511
32,30 - 36,99	16	25	31,5	210	60	150	140	HFS111SN-16B-150-ZYL-HA25-S	30026512
37,00 - 41,19	20	25	36,2	210	60	150	140	HFS111SN-20A-150-ZYL-HA25-S	30026513
41,20 - 44,99	20	25	40,2	210	60	150	140	HFS111SN-20B-150-ZYL-HA25-S	30026514
45,00 - 50,70	24	32	44	266	60	206	195	HFS111SN-24-206-ZYL-HA32-S	30026515
50,71 - 65,00									

Versione corta con codolo cilindrico

Dimensioni								Specifiche	Codice
d ₁	Dimensione HFS	d ₂ h6	d ₃	l ₁	l ₂	l ₃	l ₅		
16,60 - 19,39	10	20	16	99	50	49	33	HFS111SN-10A-049-ZYL-HA20-S	30026516
19,40 - 21,29	10	20	18,6	99	50	49	33	HFS111SN-10B-049-ZYL-HA20-S	30026521
21,30 - 24,99	12	20	20,5	117,5	50	67,5	51,5	HFS111SN-12-068-ZYL-HA20-S	30026522
25,00 - 28,99	14	25	24,2	150,5	60	90,5	71,5	HFS111SN-14-091-ZYL-HA25-S	30026523
29,00 - 32,29	16	25	28,2	149	60	89	70	HFS111SN-16A-089-ZYL-HA25-S	30026525
32,30 - 36,99	16	25	31,5	149	60	89	79	HFS111SN-16B-089-ZYL-HA25-S	30026526
37,00 - 41,19	20	25	36,2	149	60	89	79	HFS111SN-20A-089-ZYL-HA25-S	30026527
41,20 - 44,99	20	25	40,2	149	60	89	79	HFS111SN-20B-089-ZYL-HA25-S	30026528
45,00 - 50,70	24	32	44	167	60	107	96	HFS111SN-24-107-ZYL-HA32-S	30026529
50,71 - 65,00									

Misure in mm.

Fornitura: Supporto con grano a doppio effetto e cacciavite con impugnatura a T.

Supporto per testina intercambiabile HFS

Con sistema di serraggio assiale, orientamento radiale e angolare
Misure di connessione modulo secondo MN 5000-14

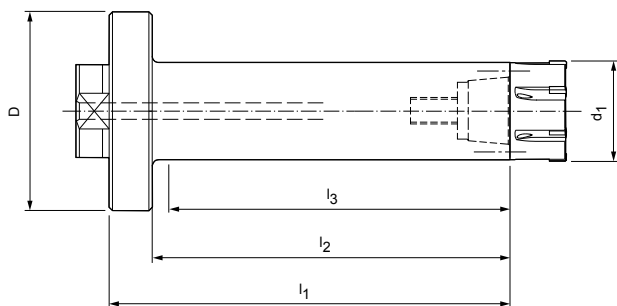

Versione lunga con sede per modulo (possibilità di orientamento radiale e angolare)

Dimensioni						Specifiche	Codice
d ₁	Dimensione HFS	D	l ₁	l ₂	l ₃		
15,60 - 18,59	10	60	81	68	61	HFS101SN-10-081-MOD-060-S	30010264
18,60 - 21,29	12	60	100,5	87,5	80,5	HFS101SN-12-101-MOD-060-S	30010265
21,30 - 23,99	14	60	101,5	88,5	79,5	HFS101SN-14-102-MOD-060-S	30010266
24,00 - 29,99	16	60	122	109	104	HFS101SN-16-122-MOD-060-S	30010267
30,00 - 39,99	20	60	121	108	103	HFS101SN-20-121-MOD-060-S	30010268
40,00 - 50,70	24	60	133	120	116	HFS101SN-24-133-MOD-060-S	30010269
50,71 - 65,00	24	80	133	116	112	HFS101SN-24-133-MOD-080-S	30190195

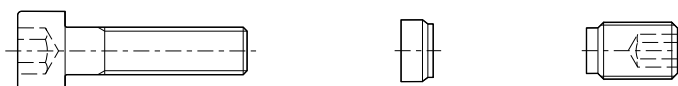

Parti di ricambio per sede per modulo

Dimensione modulo D	Vite a testa cilindrica ISO 4762 (DIN 912)			Tassello di spinta		Grano filettato	
	Quantità necessaria	Dimensioni	Codice	Dimensioni	Codice	Dimensioni	Codice
60	4	M5x16-12,9	10003601	10,6x5	10040108	M8x1x8	10040109
80	4	M6x20-12,9	10003619	10,6x5	10040108	M8x1x11,5	10075074

Misure in mm.

Fornitura: Supporto con grano a doppio effetto, cacciavite con impugnatura a T, viti di fissaggio per la sede del modulo ed elementi per l'orientamento angolare della sede del modulo.

Supporto per testina intercambiabile HFS

Con sistema di serraggio assiale, orientamento radiale e angolare
Misure di connessione modulo secondo MN 5000-14

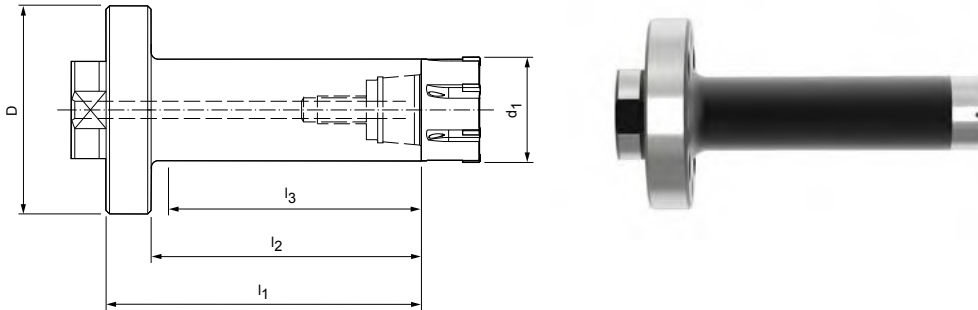

Versione corta con sede per modulo (possibilità di orientamento radiale e angolare)

Dimensioni						Specifiche	Codice
d ₁	Dimensione HFS	D	l ₁	l ₂	l ₃		
15,60 - 18,59	10	60	49	36	31	HFS101SN-10-049-MOD-060-S	30027896
18,60 - 21,29	12	60	58,5	45,5	40,5	HFS101SN-12-059-MOD-060-S	30027897
21,30 - 23,99	14	60	62,5	49,5	44,5	HFS101SN-14-063-MOD-060-S	30027898
24,00 - 29,99	16	60	72	59	54	HFS101SN-16-072-MOD-060-S	30027899
30,00 - 39,99	20	60	71	58	53	HFS101SN-20-071-MOD-060-S	30027900
40,00 - 50,70	24	60	84	71	66	HFS101SN-24-084-MOD-060-S	30027901
50,71 - 65,00	24	80	84	67	62	HFS101SN-24-084-MOD-080-S	30152510



Parti di ricambio per sede per modulo

Dimensione modulo D	Vite a testa cilindrica ISO 4762 (DIN 912)			Tassello di spinta		Grano filettato	
	Quantità necessaria	Dimensioni	Codice	Dimensioni	Codice	Dimensioni	Codice
60	4	M5x16-12,9	10003601	10,6x5	10040108	M8x1x8	10040109
80	4	M6x20-12,9	10003619	10,6x5	10040108	M8x1x11,5	10075074

Misure in mm.

Fornitura: Supporto con grano a doppio effetto, cacciavite con impugnatura a T, viti di fissaggio per la sede del modulo ed elementi per l'orientamento angolare della sede del modulo.

Supporto per testina intercambiabile HFS

Con sistema di serraggio assiale, orientamento radiale e angolare
Misure di connessione modulo secondo MN 5000-14

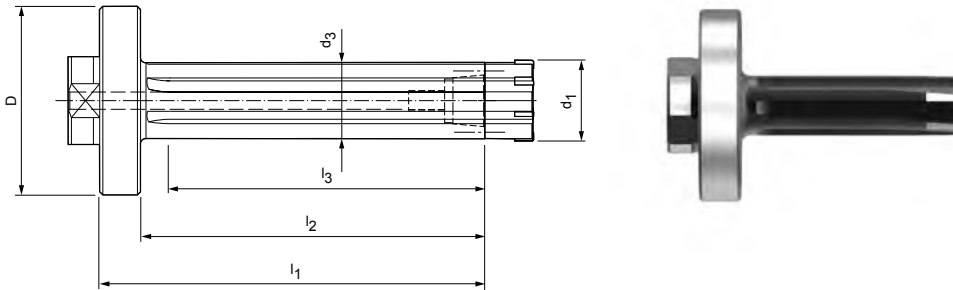

Versione lunga con sede per modulo (possibilità di orientamento radiale e angolare)

Dimensioni							Specifiche	Codice
d ₁	Dimensione HFS	D	d ₃	l ₁	l ₂	l ₃		
16,60 - 19,39	10	60	16	81	68	48	HFS111SN-10A-081-MOD-060-S	30026562
19,40 - 21,29	10	60	18,6	81	68	48	HFS111SN-10B-081-MOD-060-S	30026563
21,30 - 24,99	12	60	20,5	101,5	88,5	69,5	HFS111SN-12-102-MOD-060-S	30026564
25,00 - 28,99	14	60	24,2	122,5	109,5	90,5	HFS111SN-14-123-MOD-060-S	30026565
29,00 - 32,29	16	60	28,2	121	108	89	HFS111SN-16A-121-MOD-060-S	30026566
32,30 - 36,99	16	60	31,5	121	108	89	HFS111SN-16B-121-MOD-060-S	30026567
37,00 - 41,19	20	60	36,2	121	108	89	HFS111SN-20A-121-MOD-060-S	30026568
41,20 - 44,99	20	60	40,2	121	108	89	HFS111SN-20B-121-MOD-060-S	30026569
45,00 - 50,70	24	60	44	123	110	95	HFS111SN-24-123-MOD-060-S	30026570
50,71 - 65,00	24	80	44	133	116	110	HFS111SN-24-133-MOD-080-S	30193167



Parti di ricambio per sede per modulo

Dimensione modulo D	Vite a testa cilindrica ISO 4762 (DIN 912)			Tassello di spinta		Grano filettato	
	Quantità necessaria	Dimensioni	Codice	Dimensioni	Codice	Dimensioni	Codice
60	4	M5x16-12,9	10003601	10,6x5	10040108	M8x1x8	10040109
80	4	M6x20-12,9	10003619	10,6x5	10040108	M8x1x11,5	10075074

Misure in mm.

Fornitura: Supporto con grano a doppio effetto, cacciavite con impugnatura a T, viti di fissaggio per la sede del modulo ed elementi per l'orientamento angolare della sede del modulo.

Supporto per testina intercambiabile HFS

Con sistema di serraggio assiale, orientamento radiale e angolare
Misure di connessione modulo secondo MN 5000-14

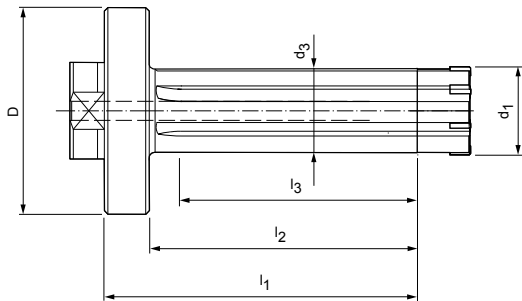

Versione corta con sede per modulo (possibilità di orientamento radiale e angolare)

Dimensioni							Specifiche	Codice
d ₁	Dimensione HFS	D	d ₃	l ₁	l ₂	l ₃		
16,60 - 19,39	10	60	16	49	36	31	HFS111SN-10A-049-MOD-060-S	30027885
19,40 - 21,29	10	60	18,6	59	46	41	HFS111SN-10B-059-MOD-060-S	30027886
21,30 - 24,99	12	60	20,5	62,5	49,5	44,5	HFS111SN-12-063-MOD-060-S	30027887
25,00 - 28,99	14	60	24,2	72,5	59,5	54,5	HFS111SN-14-073-MOD-060-S	30027888
29,00 - 32,29	16	60	28,2	71	58	53	HFS111SN-16A-071-MOD-060-S	30027889
32,30 - 36,99	16	60	31,5	71	58	53	HFS111SN-16B-071-MOD-060-S	30027890
37,00 - 41,19	20	60	36,2	71	58	53	HFS111SN-20A-071-MOD-060-S	30027891
41,20 - 44,99	20	60	40,2	81	68	63	HFS111SN-20B-081-MOD-060-S	30027892
45,00 - 50,70	24	60	44	84	71	66	HFS111SN-24-084-MOD-060-S	30027893
50,71 - 65,00	24	80	44	84	67	64	HFS111SN-24-084-MOD-080-S	30193168



Parti di ricambio per sede per modulo

Dimensione modulo D	Vite a testa cilindrica ISO 4762 (DIN 912)			Tassello di spinta		Grano filettato	
	Quantità necessaria	Dimensioni	Codice	Dimensioni	Codice	Dimensioni	Codice
60	4	M5x16-12,9	10003601	10,6x5	10040108	M8x1x8	10040109
80	4	M6x20-12,9	10003619	10,6x5	10040108	M8x1x11,5	10075074

Misure in mm.

Fornitura: Supporto con grano a doppio effetto, cacciavite con impugnatura a T, viti di fissaggio per la sede del modulo ed elementi per l'orientamento angolare della sede del modulo.

Supporto per testina intercambiabile HFS

Con sistema di serraggio assiale

Codolo conico cavo HSK-A secondo DIN 69893-1

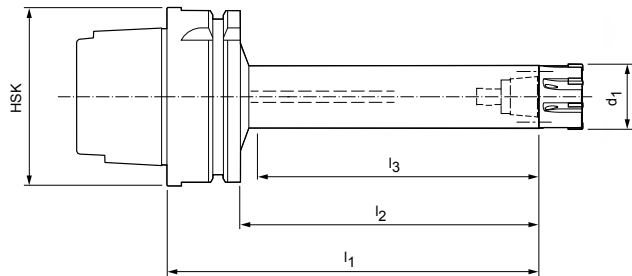

Versione lunga con HSK-A 63

Dimensioni						Specifiche	Codice
d ₁	Dimensione HFS	l ₁	l ₂	l ₃	Dimensione HSK-A		
15,60 - 18,59	10	117	91	86	63	HFS101SN-10-117-HSK-A063-S	30010272
18,60 - 21,29	12	132,5	106,5	100,5	63	HFS101SN-12-133-HSK-A063-S	30010273
21,30 - 23,99	14	131,5	105,5	99,5	63	HFS101SN-14-132-HSK-A063-S	30010275
24,00 - 29,99	16	163	137	129	63	HFS101SN-16-163-HSK-A063-S	30010276
30,00 - 39,99	20	188	162	158	63	HFS101SN-20-188-HSK-A063-S	30010280
40,00 - 50,70	24	207	181	176	63	HFS101SN-24-207-HSK-A063-S	30010286
50,71 - 65,00							

Versione corta con HSK-A 63

Dimensioni						Specifiche	Codice
d ₁	Dimensione HFS	l ₁	l ₂	l ₃	Dimensione HSK-A		
15,60 - 18,59	10	77	51	46	63	HFS101SN-10-077-HSK-A063-S	30010283
18,60 - 21,29	12	92,5	66,5	60,5	63	HFS101SN-12-093-HSK-A063-S	30010285
21,30 - 23,99	14	91,5	65,5	59,5	63	HFS101SN-14-092-HSK-A063-S	30010287
24,00 - 29,99	16	112	86	79	63	HFS101SN-16-112-HSK-A063-S	30010288
30,00 - 39,99	20	111	85	78	63	HFS101SN-20-111-HSK-A063-S	30010289
40,00 - 50,70	24	109	83	76	63	HFS101SN-24-109-HSK-A063-S	30010291
50,71 - 65,00							

Misure in mm.

Fornitura: Supporto con grano a doppio effetto e cacciavite con impugnatura a T.

Supporto per testina intercambiabile HFS

Con sistema di serraggio assiale

Codolo conico cavo HSK-A secondo DIN 69893-1

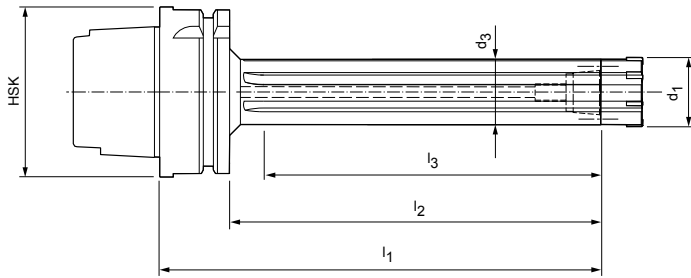

Versione lunga con HSK-A 63

Dimensioni							Specifiche	Codice
d ₁	Dimensione HFS	d ₃	l ₁	l ₂	l ₃	Dimensione HSK-A		
16,60 - 19,39	10	16,0	117	91	71	63	HFS111SN-10A-117-HSK-A063-S	30026586
19,40 - 21,29	10	18,6	117	91	71	63	HFS111SN-10B-117-HSK-A063-S	30026587
21,30 - 24,99	12	20,5	131,5	105,5	86,5	63	HFS111SN-12-132-HSK-A063-S	30026588
25,00 - 28,99	14	24,2	163,5	137,5	118,5	63	HFS111SN-14-164-HSK-A063-S	30026589
29,00 - 32,29	16	28,2	188	162	143	63	HFS111SN-16A-188-HSK-A063-S	30026590
32,30 - 36,99	16	31,5	188	162	143	63	HFS111SN-16B-188-HSK-A063-S	30026591
37,00 - 41,19	20	36,2	188	162	152	63	HFS111SN-20A-188-HSK-A063-S	30026592
41,20 - 44,99	20	40,2	188	162	152	63	HFS111SN-20B-188-HSK-A063-S	30026593
45,00 - 50,70	24	44,0	233	207	197	63	HFS111SN-24-233-HSK-A063-S	30026594
50,71 - 65,00								

Versione corta con HSK-A 63

Dimensioni							Specifiche	Codice
d ₁	Dimensione HFS	d ₃	l ₁	l ₂	l ₃	Dimensione HSK-A		
16,60 - 19,39	10	16,0	77	51	31	63	HFS111SN-10A-077-HSK-A063-S	30026574
19,40 - 21,29	10	18,6	77	51	31	63	HFS111SN-10B-077-HSK-A063-S	30026575
21,30 - 24,99	12	20,5	91,5	65,5	46,5	63	HFS111SN-12-092-HSK-A063-S	30026576
25,00 - 28,99	14	24,2	112,5	86,5	67,5	63	HFS111SN-14-113-HSK-A063-S	30026577
29,00 - 32,29	16	28,2	111	85	66	63	HFS111SN-16A-111-HSK-A063-S	30026578
32,30 - 36,99	16	31,5	111	85	66	63	HFS111SN-16B-111-HSK-A063-S	30026579
37,00 - 41,19	20	36,2	111	85	75	63	HFS111SN-20A-111-HSK-A063-S	30026580
41,20 - 44,99	20	40,2	111	85	75	63	HFS111SN-20B-111-HSK-A063-S	30026581
45,00 - 50,70	24	44,0	109	83	73	63	HFS111SN-24-109-HSK-A063-S	30026582
50,71 - 65,00								

Misure in mm.

Fornitura: Supporto con grano a doppio effetto e cacciavite con impugnatura a T.

Supporto per testina intercambiabile HFS

Con sistema di serraggio radiale, codolo secondo MN 623 analogo a DIN 1835-A

Per alesatore a testina intercambiabile HPR100, HPR110, HPR200, HPR210

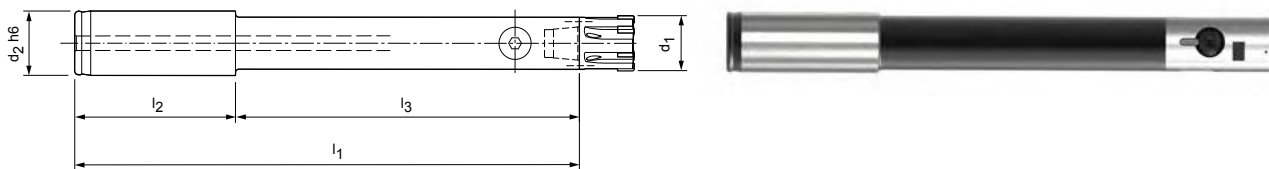

Versione lunga con codolo cilindrico

Dimensioni						Specifiche	Codice
d ₁	Dimensione HFS	d ₂ h6	l ₁	l ₂	l ₃		
18,60 - 21,29	12	20	179,5	50	129,5	HFS101RN-12-130-ZYL-HA20-S	30078110
21,30 - 23,99	14	20	180,5	50	130,5	HFS101RN-14-131-ZYL-HA20-S	30078115
24,00 - 29,99	16	25	211	60	151	HFS101RN-16-151-ZYL-HA25-S	30078116
30,00 - 39,99	20	25	210	60	150	HFS101RN-20-150-ZYL-HA25-S	30080112

Versione corta con codolo cilindrico

Dimensioni						Specifiche	Codice
d ₁	Dimensione HFS	d ₂ h6	l ₁	l ₂	l ₃		
18,60 - 21,29	12	20	118,5	50	68,5	HFS101RN-12-069-ZYL-HA20-S	30078117
21,30 - 23,99	14	20	119,5	50	69,5	HFS101RN-14-070-ZYL-HA20-S	30078118
24,00 - 29,99	16	25	150	60	90	HFS101RN-16-090-ZYL-HA25-S	30078119
30,00 - 39,99	20	25	149	60	89	HFS101RN-20-089-ZYL-HA25-S	30080151

Versione ultra-corta con codolo cilindrico

Dimensioni						Specifiche	Codice
d ₁	Dimensione HFS	d ₂ h6	l ₁	l ₂	l ₃		
18,60 - 21,29	12	20	85	50	35	HFS101RN-12-035-ZYL-HA20-S	30115560

Misure in mm.

Raccomandazione: Per consentire un cambio rapido degli alesatori con il sistema di serraggio radiale, è bene ordinare come minimo un perno di bloccaggio aggiuntivo.

Fornitura: Supporto con perno di bloccaggio, cacciavite con impugnatura a T e chiave a bocca per il perno di bloccaggio.



Accessori e parti di ricambio per HFS



Grano a doppio effetto per sistema di serraggio assiale

Dimensione HFS	senza adduzione per il refrigerante Grano a doppio effetto MN 618 Codice	con adduzione per il refrigerante Grano a doppio effetto MN 618 Codice
10	10024720	10025194
12	10024721	10025195
14	10024721	10025195
16	10024722	10025196
20	10024722	10025196
24	10024723	10025198



Perno di bloccaggio per sistema di serraggio radiale

Dimensione HFS	senza foro per refrigerante Codice	con foro per il refrigerante Codice
12	10059113	10059273
14	10059113	10059273
16	10059117	10059279
20	10059117	10059279

Raccomandazione: Per consentire un cambio rapido degli alesatori con il sistema di serraggio radiale, è bene ordinare come minimo un perno di bloccaggio aggiuntivo.

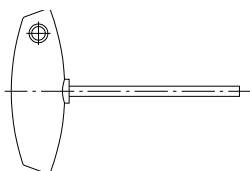

Cacciavite con impugnatura a T

Dimensione HFS	versione corta		versione lunga	
	Dimensioni	Codice	Dimensioni	Codice
10	sw2,5 x 100	10006233	sw2,5 x 200	10032722
12	sw3 x 100	10006234	sw3 x 200	10025313
14	sw3 x 100	10006234	sw3 x 200	10025313
16	sw4 x 100	10006235	sw4 x 200	10018010
20	sw4 x 100	10006235	sw4 x 200	10018010
24	sw5 x 100	10006236	sw5 x 200	10013349

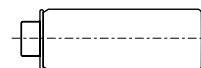

Dispositivo di pulizia per cono interno HFS

Dimensione HFS	Codice
10	10029989
12	10029990
14	10030002
16	10030003
20	10030004
24	10030005

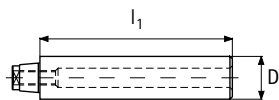

Spine di controllo (ausilio di allineamento)

Dimensione HFS	l_1	D	Codice
10	70	15	30036468
12	80	20	30036469
14	80	20,5	30036470
16	80	23,2	30036471
20	80	29,3	30036472
24	80	39	30036473

Misure in mm.

Versione: Eccentricità dell'elemento cilindrico consentita rispetto all'innesto HFS max. 0,002 mm.

Accessori e parti di ricambio per HSK-A 63

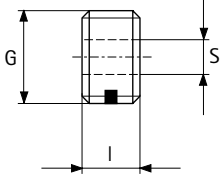

Vite cieca

Dimensione HSK-A	I	S	G	Codice
63	11,5	8	M18x1	30326078

Dimen- sione HFS	sw	Chiave dinamometrica				Lame e inserti esagonali per chiave dinamometrica			
		Coppia di serraggio	Versione	Trasmissione	Codice	l [mm]	l ₁ [mm]	Trasmissione	Codice
10	2.5	4 Nm	fissa - con lama	-	10044842	175	70	Lama	10044839
12	3	6 Nm	regolabile - senza inserto	1/4"	10040125	55	30	Inserto 1/4"	10040122
14	3	6 Nm	regolabile - senza inserto	1/4"	10040125	55	30	Inserto 1/4"	10040122
16	4	15 Nm	regolabile - senza inserto	3/8"	10040126	60	35	Inserto 3/8"	10040123
20	4	15 Nm	regolabile - senza inserto	3/8"	10040126	60	35	Inserto 3/8"	10040123
24	5	20 Nm	regolabile - senza inserto	3/8"	10040126	70	45	Inserto 3/8"	10040124

Chiave dinamometrica e inserti esagonali solo a partire da dimensione HFS 12 oppure sw 3.

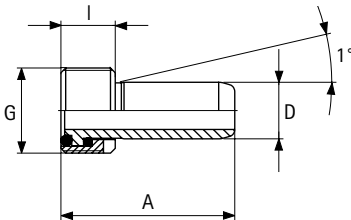

Tubo refrigerante

Dimensione HSK-A	A	I	G	D	Codice
63	36.6	11,5	M18x1	12	30326006

Fornitura: canale del refrigerante con due o-ring e dado.

Versione: pratica mobilità angolare autocentrante a 1°, a tenuta assiale.

Nota: Realizzato secondo la normativa DIN 69893.

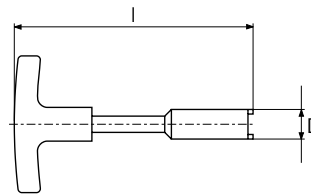

Chiave di montaggio

Dimensione HSK-A	I	D	Codice
63	182	17	10040110

Utilizzo: Per il montaggio e lo smontaggio di tubi del refrigerante.

Misure in mm.

Utilizzo: per la chiusura del foro filettato nei codoli conici cavi HSK dell'utensile, qualora non si utilizzi alcun canale del refrigerante.

Versione: con inserto Nylok per il bloccaggio delle viti.

Materiale: acciaio inossidabile.



UTENSILI CON PATTINI DI GUIDA

Utensili con pattini di guida

Riepilogo del programma alesatori a un tagliente	478
Codice di denominazione	480

Alesatori WP a un tagliente

MN2000	484
MN2003	486
MN2004	488
MN2034	489
MN2023	490
MN2024	491
MN2043	492
MN2044	493
Inseri a fissaggio meccanico con imbocco AS AZ DZ EK SZ ..	494
Parametri di lavorazione consigliati	504

Sistema EasyAdjust

Panoramica prodotti, utilizzo e riepilogo sistema	514
Rastremazione dei taglienti	516
Riepilogo del programma	517
Inseri a fissaggio meccanico HX per sistema EA	518
Inseri a fissaggio meccanico TEC per sistema EA	520
Accessori	522
Parametri di lavorazione consigliati	524

Utensili per la lavorazione esterna

Panoramica prodotti, utilizzo e riepilogo sistema	538
Inseri a fissaggio meccanico TEC	540
Inseri a fissaggio meccanico	542
Accessori	544
Parametri di lavorazione consigliati	546

Allegato tecnico

Indicazioni per l'utilizzo	737
----------------------------------	-----



Riepilogo del programma – Alesatori a un tagliente

Concezione della macchina		Tipo di adduzione del refrigerante		Tipo di foro		Numero di taglienti	Forma del codolo	
Alesatori a un tagliente	Macchine per foratura		✓	✓		1		Codolo conico Morse
Alesatori a un tagliente	Tornio automatico (con supporto oscillante)	✓		✓		1		Codolo cilindrico con superficie di serraggio
		✓			✓	1		
		✓			✓	1		
Alesatori a un tagliente	Centri di lavorazione	✓		✓		1		Codolo cilindrico con superficie di serraggio NC
		✓			✓	1		
		✓		✓		1		Codolo cilindrico liscio
		✓			✓	1		

Imbocchi per inserti a fissaggio meccanico MAPAL

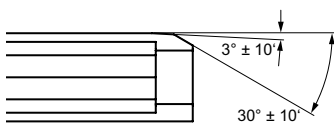

Imbocco AS

Imbocco adatto a tutti i materiali, alta qualità della superficie anche con velocità di taglio elevate. Lunghezza di imbocco 1,3 mm.

Profondità max. di passata assiale: 0,25 mm
Angolo di spoglia: 0°, 6°, 12°

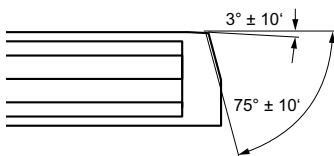

Imbocco AZ

Per velocità di taglio elevate, adatto in particolare alla lavorazione dell'alluminio.



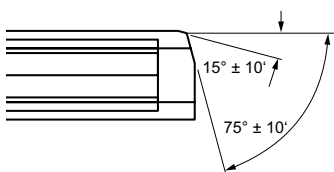







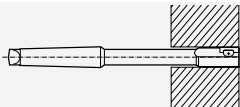

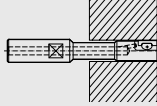

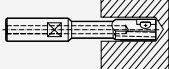

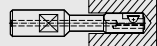
Profondità max. di passata assiale: 0,5 mm
Angolo di spoglia: 0°, 6°, 12°

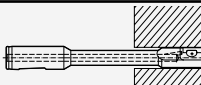

Imbocco DZ

Specifico per materiali a trucioli corti (GG) e grandi profondità di passata assiale. L'angolo di imbocco del tagliente di finitura di 15° aumenta leggermente le forze radiali ed è pertanto adatto anche a elementi con pareti sottili.

Profondità max. di passata assiale: 0,15 mm
Angolo di spoglia: 0°, 6°, 12°

Utensile	Tagliente		Pagina	Serie
Serie	Denominazione			
MN2000	Alesatore WP 		484	MN2000 Versione con codolo MK 
MN2003	Alesatore WP 		486	MN2003 Versione corta con adduzione interna del refrigerante 
MN2004			488	MN2004 Versione corta 
MN2034 (Versione corta)			489	MN2034 Versione ultra-corta 
MN2023	Alesatore WP NC 		490	MN2023 Struttura costruttiva NC 
MN2024			491	MN2024 Struttura costruttiva NC 
MN2043			492	MN2043 Struttura costruttiva NC 
MN2044			493	MN2044 Struttura costruttiva NC 

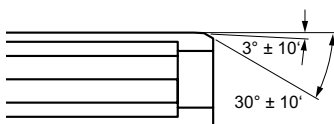

Imbocco EK

Da utilizzarsi solo quando è richiesta una lunghezza di imbocco ridotta pari a 0,6 mm. Adatto a tutti i materiali, non superare avanzamento max. pari a 0,2 mm/giri.

Profondità max. di passata assiale: 0,15 mm
Angolo di spoglia: 0°, 6°, 12°

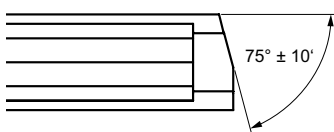

Imbocco SZ

Specifico per leghe di alluminio pressofuso, buona superficie su piccoli avanzamenti. I profili vengono rispettati con precisione. L'angolo di imbocco del tagliente principale di 75° riduce le forze radiali ed è pertanto particolarmente adatto a elementi con pareti sottili.

Profondità max. di passata assiale: 1,0 mm
Angolo di spoglia: 6°, 12°

Codice di denominazione

Alesatore WP

M	N	2	0	0	0
---	---	---	---	---	---

Denominazione
Serie

H	M
---	---

Qualità del pattino di
guida

HM	Metallo duro
CT	Cermet

1	2
---	---

Diametro di
produzione

Sistema EasyAdjust

E	A	S
---	---	---

Denominazione
(EasyAdjust-System)
Serie

R

Direzione di taglio

R	Destra
L	Sinistra
N	Neutro

6	3
---	---

Tagliente

6	HX
4	TEC

M

Rastremazione

Dimensione sistema

GR	HX	TEC
2	Adduzione interna refrigerante Ø = 6	Adduzione interna refrigerante Ø = 6,35
3	Adduzione interna refrigerante Ø = 10	Adduzione interna refrigerante Ø = 9,525

H	7
----------	----------

Tolleranza IT
oppure misure

A	S
----------	----------

Denominazione
imbocco

AS	Informazioni sull'applicazione a pagina 478/479
AZ	
DZ	
EK	
SZ	

Codice di denominazione

Inserti a fissaggio meccanico



Dimensioni
81 | 90 | 91 | 92 | 93

Selezionare la dimensione adatta alla versione dell'alesatore.
Per l'assegnazione vedere tabelle prodotti.

Indicare solo per versioni
smusso F.

A S

9 2

R F 0

Forma di imbocco
AS = 3°/30° lunghezza 1,3 mm
AZ = 3°/75° Lunghezza 1,3 mm
DZ = 15°/75° Lunghezza 0,55 mm
EK = 3°/30° lunghezza 0,6 mm
SZ = 0°/75° lunghezza 0,55 mm

Senso di taglio
R = Taglio a destra
L = Taglio a sinistra

Dimensioni angolo di
spoglia
0 = 0°
6 = 6°
2 = 12°

Inserti a fissaggio meccanico HX



H X

1

3

Imbocco
8 = R 0,8

8

Forma esagonale
Esagonale

Geometria rompitruciolo
(angolo di spoglia)
1 = Altamente positivo
2 = Positivo

Dimensione dell'inserto
2 = Circonferenza inscritta \varnothing 6 mm
3 = Circonferenza inscritta \varnothing 10 mm

Inserti a fissaggio meccanico TEC



T E C

2

0 8

F 0 1

Forma inserto
(tetragonale)

Dimensione dell'inserto
2 = \varnothing circonferenza in-
scritta: 6,35
3 = \varnothing circonferenza in-
scritta: 9,525

Forma di imbocco
04 = R = 0,4
08 = R = 0,8
AS = 3°/30° lunghezza 1,3
EK = 3°/30° lunghezza 0,6
DZ = 15°/75° Lunghezza
0,55

Versione dei bordi di taglio
F01 = spigolo vivo
E02 = Arrotondato
S35 = Smusso negativo e arroton-
dato

H	U	6	1	5
---	---	---	---	---

Qualità del materiale da taglio
ad es.: HU = metallo duro non rivestito

R	L
---	---

Senso di taglio
RL = taglio a destra e sinistra

C	U	1	3	4
---	---	---	---	---

Qualità del materiale da taglio
ad es.: HU = metallo duro non rivestito

Optional:
Smusso F

R

Direzione di taglio
R = Taglio a destra
L = Taglio a sinistra
N = taglio destro/sinistro
(neutro)

F

Rompitruciolo
1a posizione
0 = senza caratteristica
1 = Parallelo positivo

1	G
---	---

Rompitruciolo 2a posizione (angolo di spoglia)

A = 0° N = 12°
G = 6° U = 18°
J = 8°

F

Solo con taglienti rivestiti
F = Tutta la superficie di materiale
su un lato (smusso pieno)

-	H	U	6	1	2
---	---	---	---	---	---

Qualità del materiale da taglio
(esempio)



Alesatore WP a un tagliente MN2000

Versione con codolo MK

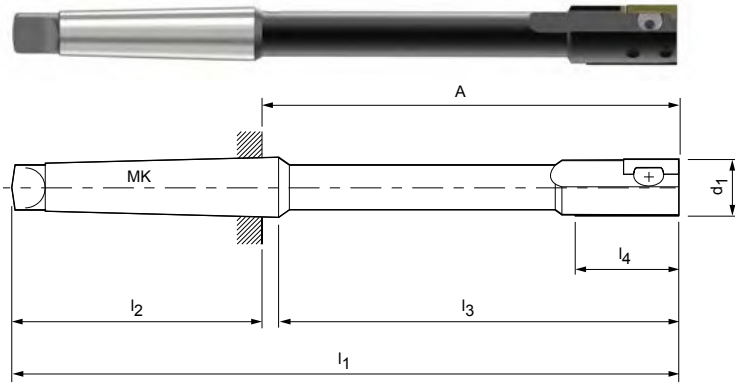

Dimensioni							Dimensione dell'inserito	Accessori				
d_1^*	l_1	l_2	l_3	l_4	MK	A		Serraggio		Regolazione		
								Vite Torx/Grano a doppio effetto	Staffa di serraggio	Grano filettato MN 620	Cuneo di regolazione MN 619	
								Codice (dimensione)				
5,00 - 5,29	126**	62	60,5	15	1	64	(SP) 81	Vite Torx	10036776 (M1,6x3,9)	30026285 (GR - 1YN)	10036736 (M2x1,8)	30026239 (GR - 06)
5,30 - 5,49	126**	62	60,5	15	1	64	(SP) 81		10036778 (M1,6x4,4)	30026285 (GR - 1YN)	10036737 (M2x2)	30026239 (GR - 06)
5,50 - 6,19	126**	62	60,5	15	1	64	(SP) 81		10036780 (M2x4)	30026286 (GR - 1X)	10036737 (M2x2)	30026260 (GR - 07)
6,20 - 6,90	126**	62	60,5	15	1	64	(SP) 81		10036781 (M2x5)	30026286 (GR - 1X)	10036738 (M2x2,5)	30026260 (GR - 07)
6,91 - 7,49	136**	62	70,5	15	1	74	90		10036783 (M2,5x4,8)	30026287 (GR - 1W)	10036730 (M2,5x2,2)	30026261 (GR - 08)
7,50 - 7,79	136**	62	70,5	15	1	74	90		10036784 (M2,5x5,2)	30026287 (GR - 1W)	10036731 (M2,5x2,5)	30026262 (GR - 09)
7,80 - 7,99	155	62	89,5	30	1	93	90		10036711 (M3LH/RHx5)	30026288 (GR - 0F)	10036743 (M3x2,5)	30026238 (GR - 0)
8,00 - 8,79	155	62	89,5	30	1	93	90		10036711 (M3LH/RHx5)	30026288 (GR - 0F)	10036743 (M3x2,5)	30026238 (GR - 0)
8,80 - 9,29	160	62	94,5	30	1	98	90		10036722 (M3LH/RHx6)	30026289 (GR - 0N)	10036744 (M3x3)	30026238 (GR - 0)
9,30 - 9,79	170	62	104,5	30	1	108	91	10036722 (M3LH/RHx6)	30026292 (GR - 1N)	10036744 (M3x3)	30026238 (GR - 0)	
9,80 - 11,29	170	62	104,5	30	1	108	91	10036722 (M3LH/RHx6)	30026292 (GR - 1N)	10036744 (M3x3)	30026263 (GR - 1)	
11,30 - 11,79	170	62	104,5	30	1	108	92	10036724 (M4x0,5LH/RHx6,5)	30026294 (GR - 2F)	10036751 (M4x3)	30026266 (GR - 2)	
11,80 - 12,29	170	62	104,5	30	1	108	92	10036724 (M4x0,5LH/RHx6,5)	30026294 (GR - 2F)	10036751 (M4x3)	30026266 (GR - 2)	
12,30 - 13,29	180	62	114,5	30	1	118	92	10036724 (M4x0,5LH/RHx6,5)	30026294 (GR - 2F)	10036752 (M4x4)	30026266 (GR - 2)	
13,30 - 14,29	180	62	114,5	30	1	118	92	10036725 (M4x0,5LH/RHx9)	30026296 (GR - 2N)	10036753 (M4x5)	30026266 (GR - 2)	
14,30 - 15,29	180	62	114,5	30	1	118	92	10036725 (M4x0,5LH/RHx9)	30026296 (GR - 2N)	10036753 (M4x5)	30026266 (GR - 2)	
15,30 - 16,29	200	75	120	30	2	125	92	10036725 (M4x0,5LH/RHx9)	30026296 (GR - 2N)	10036753 (M4x5)	30026266 (GR - 2)	
16,30 - 18,29	210	75	130	30	2	135	92	10036725 (M4x0,5LH/RHx9)	30026296 (GR - 2N)	10036753 (M4x5)	30026266 (GR - 2)	
18,30 - 20,29	220	75	140	30	2	145	92	10036725 (M4x0,5LH/RHx9)	30026296 (GR - 2N)	10036755 (M4x8)	30026266 (GR - 2)	

Esempio di ordine (vedere pag. 480): MN2000 HM 11,8 H7 AS

Misure in mm.

Ulteriori dimensioni disponibili su richiesta.

SP = inserto, non ribaltabile.

Per le indicazioni sulla regolazione e per il montaggio dei componenti accessori vedere il capitolo "Allegato tecnico".

* I valori non indicano il range di regolazione, bensì le dimensioni costruttive per i diversi diametri (regolabile solo nei limiti del range di tolleranza).

** Con perno di centraggio di lunghezza 2,5 mm in caso di d_1 minore di 7,8 mm.

Al momento dell'ordine indicare la qualità desiderata per i pattini di guida (metallo duro, cermet).

In mancanza di indicazioni al riguardo, i pattini di guida verranno realizzati in metallo duro. Utensili con pattini di guida in qualità PCD disponibili a partire da \varnothing 8 mm.

Riparazioni per motivi tecnici possibili a partire da \varnothing 8,00

Prezzo e tempi di consegna per utensili con pattini di guida in qualità PCD su richiesta.

Inserti a fissaggio meccanico idonei da pagina 494.

Alesatore WP a un tagliente MN2003

Versione corta con adduzione interna del refrigerante

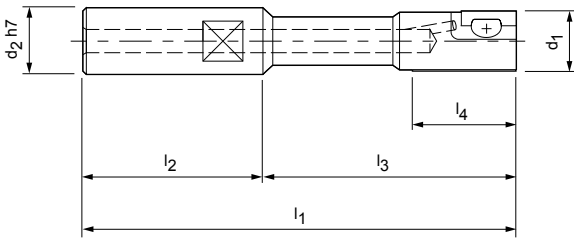

Dimensioni							Accessori				
d ₁ *	d ₂ H7	l ₁	l ₂	l ₃	l ₄	Dimensione dell'inserito	Serraggio		Regolazione		
							Vite Torx/Grano a doppio effetto	Staffa di serraggio	Grano filettato MN 620	Cuneo di regolazione MN 619	
							Codice (dimensione)				
5,00 - 5,29	10	90**	30	60	15	(SP) 81	Vite Torx	10036776 (M1,6x3,9)	30026285 (GR - 1YN)	10036736 (M2x1,8)	30026239 (GR - 06)
5,30 - 5,49	10	90**	30	60	15	(SP) 81		10036778 (M1,6x4,4)	30026285 (GR - 1YN)	10036737 (M2x2)	30026239 (GR - 06)
5,50 - 6,19	10	90**	30	60	15	(SP) 81		10036780 (M2x4)	30026286 (GR - 1X)	10036737 (M2x2)	30026260 (GR - 07)
6,20 - 6,90	10	90**	30	60	15	(SP) 81		10036781 (M2x5)	30026286 (GR - 1X)	10036738 (M2x2,5)	30026260 (GR - 07)
6,91 - 7,49	10	100**	30	70	15	90		10036783 (M2,5x4,8)	30026287 (GR - 1W)	10036730 (M2,5x2,2)	30026261 (GR - 08)
7,50 - 7,79	10	100**	30	70	15	90		10036784 (M2,5x5,2)	30026287 (GR - 1W)	10036731 (M2,5x2,5)	30026262 (GR - 09)
7,80 - 8,29	16	120	45	75	30	90		10036711 (M3LH/RHx5)	30026288 (GR - 0F)	10036743 (M3x2,5)	30026238 (GR - 0)
8,30 - 8,79	16	120	45	75	30	90		10036711 (M3LH/RHx5)	30026288 (GR - 0F)	10036744 (M3x3)	30026238 (GR - 0)
8,80 - 9,29	16	120	45	75	30	90		10036722 (M3LH/RHx6)	30026289 (GR - 0N)	10036744 (M3x3)	30026238 (GR - 0)
9,30 - 9,79	16	120	45	75	30	91		10036722 (M3LH/RHx6)	30026292 (GR - 1N)	10036744 (M3x3)	30026238 (GR - 0)
9,80 - 11,29	16	120	45	75	30	91	Grano a doppio effetto MN 618	10036722 (M3LH/RHx6)	30026292 (GR - 1N)	10036744 (M3x3)	30026263 (GR - 1)
11,30 - 11,79	16	120	45	75	30	92		10036724 (M4x0,5LH/RHx6,5)	30026294 (GR - 2F)	10036751 (M4x3)	30026266 (GR - 2)
11,80 - 12,29	16	120	45	75	30	92		10036724 (M4x0,5LH/RHx6,5)	30026294 (GR - 2F)	10036751 (M4x3)	30026266 (GR - 2)
12,30 - 13,29	16	120	45	75	30	92		10036724 (M4x0,5LH/RHx6,5)	30026294 (GR - 2F)	10036752 (M4x4)	30026266 (GR - 2)
13,30 - 14,29	16	120	45	75	30	92		10036725 (M4x0,5LH/RHx9)	30026296 (GR - 2N)	10036753 (M4x8)	30026266 (GR - 2)
14,30 - 18,29	20	130	55	75	30	92		10036725 (M4x0,5LH/RHx9)	30026296 (GR - 2N)	10036753 (M4x8)	30026266 (GR - 2)
18,30 - 19,79	20	130	55	75	30	92		10036725 (M4x0,5LH/RHx9)	30026296 (GR - 3N)	10036755 (M6x15)	30026266 (GR - 4)
19,80 - 20,29	20	150	55	95	30	92		10036725 (M4x0,5LH/RHx9)	30026296 (GR - 3N)	10036755 (M6x15)	30026266 (GR - 4)

Alesatore WP a un tagliente MN2003

Dimensioni						Dimensio- ne dell'in- serto	Accessori				
d ₁ *	d ₂ H7	l ₁	l ₂	l ₃	l ₄		Serraggio		Regolazione		
							Vite Torx/Grano a doppio effetto	Staffa di ser- raggio	Grano filettato MN 620	Cuneo di regolazione MN 619	
							Codice (dimensione)				
20,30 - 26,29	20	150	55	95	30	92	MN 618	10036725 (M4x0,5LH/RHx9)	30026296 (GR - 2N)	10036755 (M4x8)	30026266 (GR - 2)
26,30 - 30,29	25	160	65	95	30	92		10036725 (M4x0,5LH/RHx9)	30026296 (GR - 2N)	10036755 (M4x8)	30026266 (GR - 2)

Esempio di ordine (vedere pag. 480):
MN2003 HM 20,99 H7 AS

Misure in mm.

Ulteriori dimensioni disponibili su richiesta.

SP = inserto, non ribaltabile.

Per le indicazioni sulla regolazione e per il montaggio dei componenti accessori vedere il capitolo "Allegato tecnico".

* I valori non indicano il range di regolazione, bensì le dimensioni costruttive per i diversi diametri (regolabile solo nei limiti del range di tolleranza).

** Con perno di centraggio di lunghezza 2,5 mm in caso di d₁ minore di 7,8 mm.

Al momento dell'ordine indicare la qualità desiderata per i pattini di guida (metallo duro, cermet).

In mancanza di indicazioni al riguardo, i pattini di guida verranno realizzati in metallo duro. Utensili con pattini di guida in qualità PCD disponibili a partire da Ø 8 mm.

Riparazioni per motivi tecnici possibili a partire da Ø 8.00

Prezzo e tempi di consegna per utensili con pattini di guida in qualità PCD su richiesta.

Inserti a fissaggio meccanico idonei da pagina 494.

Alesatore WP a un tagliente MN2004

Versione corta

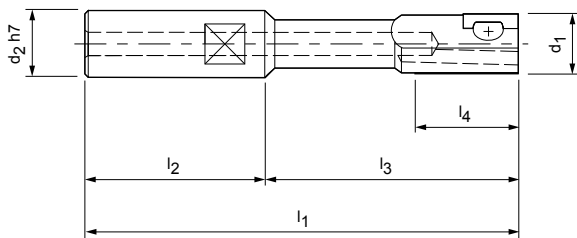

Dimensioni							Accessori				
d ₁ *	d ₂ H7	l ₁	l ₂	l ₃	l ₄	Dimensione dell'inserito	Serraggio		Regolazione		
							Vite Torx/Grano a doppio effetto	Staffa di serraggio	Grano filettato MN 620	Cuneo di regolazione MN 619	
							Codice (dimensione)				
5,90 - 6,29	10	90**	30	60	15	(SP) 81	Vite Torx	10036776 (M1,6x3,9)	30026285 (GR - 1YN)	10036737 (M2x2)	30026239 (GR - 06)
6,30 - 6,90	10	90**	30	60	15	(SP) 81		10036778 (M1,6x4,4)	30026285 (GR - 1YN)	10036738 (M2x2,5)	30026239 (GR - 06)
6,91 - 7,29	10	100**	30	70	15	(SP) 81		10036778 (M1,6x4,4)	30026285 (GR - 1YN)	10036738 (M2x2,5)	30026239 (GR - 06)
7,30 - 7,79	10	100**	30	70	15	(SP) 81		10036781 (M2x5)	30026286 (GR - 1X)	10036739 (M2x3)	30026260 (GR - 07)
7,80 - 8,29	16	120**	45	75	15	(SP) 81		10036781 (M2x5)	30026286 (GR - 1X)	10036739 (M2x3)	30026260 (GR - 07)
8,30 - 9,79	16	120	45	75	15	90		10036784 (M2,5x5,2)	30026287 (GR - 1W)	10036732 (M2,5x3)	30026262 (GR - 09)
9,80 - 10,29	16	120	45	75	15	90		10036784 (M2,5x5,2)	30026287 (GR - 1W)	10036733 (M2,5x4)	30026262 (GR - 09)
10,30 - 11,29	16	120	45	75	30	90		10036722 (M3LH/RHx6)	30026289 (GR - 0N)	10036744 (M3x3)	30026263 (GR - 1)
11,30 - 12,29	16	120	45	75	30	90		10036722 (M3LH/RHx6)	30026289 (GR - 0N)	10036745 (M3x4)	30026263 (GR - 1)
12,30 - 14,29	16	120	45	75	30	91		10036722 (M3LH/RHx6)	30026292 (GR - 1N)	10036745 (M3x4)	30026263 (GR - 1)
14,30 - 16,29	20	130	55	75	30	91	Grano a doppio effetto MN 618	10036722 (M3LH/RHx6)	30026292 (GR - 1N)	10036747 (M3x6)	30026263 (GR - 1)
16,30 - 17,29	20	130	55	75	30	92		10036725 (M4x0,5LH/RHx9)	30026296 (GR - 2N)	10036753 (M4x5)	30026266 (GR - 2)
17,30 - 19,79	20	130	55	75	30	92		10036725 (M4x0,5LH/RHx9)	30026296 (GR - 2N)	10036754 (M4x6)	30026266 (GR - 2)
19,80 - 26,29	20	150	55	95	30	92		10036725 (M4x0,5LH/RHx9)	30026296 (GR - 2N)	10036755 (M4x8)	30026266 (GR - 2)
26,30 - 30,29	25	160	65	95	30	92		10036725 (M4x0,5LH/RHx9)	30026296 (GR - 2N)	10036755 (M4x8)	30026266 (GR - 2)

Esempio di ordine (vedere pag. 480):
MN2004 HM 20,99 H7 AS

Misure in mm.

Ulteriori dimensioni disponibili su richiesta.

Per le indicazioni sulla regolazione e per il montaggio dei componenti accessori vedere il capitolo "Allegato tecnico".

* I valori non indicano il range di regolazione, bensì le dimensioni costruttive per i diversi diametri (regolabile solo nei limiti del range di tolleranza).

** Con perno di centraggio di lunghezza 1 mm in caso di d₁ minore di 8,3 mm.

Al momento dell'ordine indicare la qualità desiderata per i pattini di guida (metallo duro, cermet).

In mancanza di indicazioni al riguardo, i pattini di guida verranno realizzati in metallo duro. Utensili con pattini di guida in qualità PCD disponibili a partire da Ø 8 mm.

Riparazioni per motivi tecnici possibili a partire da Ø 8.00

Prezzo e tempi di consegna per utensili con pattini di guida in qualità PCD su richiesta.

Inseriti a fissaggio meccanico idonei da pagina 494.

Alesatore WP a un tagliente MN2034

Versione ultra-corta

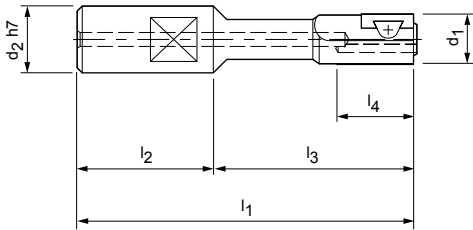

Dimensioni						Dimensione dell'inserito	Accessori				
d ₁ *	d ₂ H7	l ₁	l ₂	l ₃	l ₄		Serraggio		Regolazione		
							Vite Torx/Grano a doppio effetto	Staffa di serraggio	Grano filettato MN 620	Cuneo di regolazione MN 619	
							Codice (dimensione)				
5,90 - 6,29	16	85**	27	58	15	(SP) 81	Vite Torx	10036776 (M1,6x3,9)	30026285 (GR - 1YN)	10036737 (M2x2)	30026239 (GR - 06)
6,30 - 7,29	16	85**	27	58	15	(SP) 81		10036778 (M1,6x4,4)	30026285 (GR - 1YN)	10036738 (M2x2,5)	30026239 (GR - 06)
7,30 - 8,29	16	85**	27	58	15	(SP) 81		10036781 (M2x5)	30026286 (GR - 1X)	10036739 (M2x3)	30026260 (GR - 07)
8,30 - 9,79	16	85	27	58	15	90		10036784 (M2,5x5,2)	30026287 (GR - 1W)	10036732 (M2,5x3)	30026262 (GR - 09)
9,80 - 10,29	16	85	27	58	15	90		10036784 (M2,5x5,2)	30026287 (GR - 1W)	10036733 (M2,5x4)	30026262 (GR - 09)
10,30 - 11,29	16	85	27	58	30	90	Grano a doppio effetto MN 618	10036722 (M3LH/RHx6)	30026289 (GR - 0N)	10036744 (M3x3)	30026263 (GR - 1)
11,30 - 12,29	16	85	27	58	30	90		10036722 (M3LH/RHx6)	30026289 (GR - 0N)	10036745 (M3x4)	30026263 (GR - 1)
12,30 - 14,29	16	85	27	58	30	91		10036722 (M3LH/RHx6)	30026292 (GR - 1N)	10036745 (M3x4)	30026263 (GR - 1)
14,30 - 16,29	16	85	27	58	30	91		10036722 (M3LH/RHx6)	30026292 (GR - 1N)	10036747 (M3x6)	30026263 (GR - 1)
16,30 - 17,29	16	85	27	58	30	92		10036725 (M4x0,5LH/RHx9)	30026296 (GR - 2N)	10036753 (M4x5)	30026266 (GR - 2)
17,30 - 19,79	16	85	27	58	30	92		10036725 (M4x0,5LH/RHx9)	30026296 (GR - 2N)	10036754 (M4x6)	30026266 (GR - 2)
19,80 - 20,29	16	85	27	58	30	92		10036725 (M4x0,5LH/RHx9)	30026296 (GR - 2N)	10036755 (M4x8)	30026266 (GR - 2)
20,30 - 26,30	20	90	30	60	30	92		10036725 (M4x0,5LH/RHx9)	30026296 (GR - 2N)	10036755 (M4x8)	30026266 (GR - 2)
26,30 - 30,29	25	90	30	60	30	92		10036725 (M4x0,5LH/RHx9)	30026296 (GR - 2N)	10036755 (M4x8)	30026266 (GR - 2)

Esempio di ordine (vedere pag. 480):
MN2034 HM 20,99 H7 AS

Misure in mm.

Ulteriori dimensioni disponibili su richiesta.

SP = inserto, non ribaltabile.

Per le indicazioni sulla regolazione e per il montaggio dei componenti accessori vedere il capitolo "Allegato tecnico".

* I valori non indicano il range di regolazione, bensì le dimensioni costruttive per i diversi diametri (regolabile solo nei limiti del range di tolleranza).

** Con perno di centraggio di lunghezza 1 mm in caso di d₁ minore di 8,3 mm.

Al momento dell'ordine indicare la qualità desiderata per i pattini di guida (metallo duro, cermet).

In mancanza di indicazioni al riguardo, i pattini di guida verranno realizzati in metallo duro. Utensili con pattini di guida in qualità PCD disponibili a partire da Ø 8 mm.

Riparazioni per motivi tecnici possibili a partire da Ø 8.00

Prezzo e tempi di consegna per utensili con pattini di guida in qualità PCD su richiesta.

Inserti a fissaggio meccanico idonei da pagina 494.

Alesatore WP a un tagliente MN2023

Struttura costruttiva NC

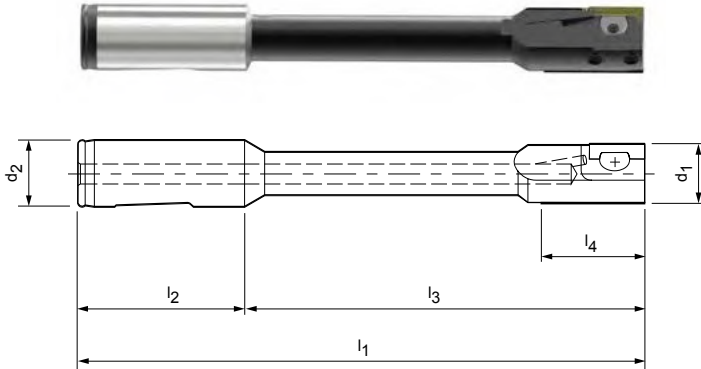

Dimensioni							Accessori			
d ₁ *	d ₂ (-0,003)	l ₁	l ₂	l ₃	l ₄	Dimensione dell'inserito	Serraggio		Regolazione	
							Grano a doppio effetto MN 618	Staffa di serraggio	Grano filettato MN 620	Cuneo di regolazione MN 619
Codice (dimensione)										
7,80 - 8,29	16	133	48	85	30	90	10036711 (M3LH/RHx5)	30026288 (GR - 0F)	10036743 (M3x2,5)	30026238 (GR - 0)
8,30 - 8,79	16	133	48	85	30	90	10036711 (M3LH/RHx5)	30026288 (GR - 0F)	10036744 (M3x3)	30026238 (GR - 0)
8,80 - 9,29	16	133	48	85	30	90	10036711 (M3LH/RHx5)	30026289 (GR - 0N)	10036744 (M3x3)	30026238 (GR - 0)
9,30 - 11,29	16	133	48	85	30	91	10036722 (M3LH/RHx6)	30026292 (GR - 1N)	10036744 (M3x3)	30026263 (GR - 1)
11,30 - 11,79	16	133	48	85	30	92	10036724 (M4x0,5LH/RHx6,5)	30026294 (GR - 2F)	10036751 (M4x3)	30026266 (GR - 2)
11,80 - 12,29	16	168	48	120	30	92	10036724 (M4x0,5LH/RHx6,5)	30026294 (GR - 2F)	10036751 (M4x3)	30026266 (GR - 2)
12,30 - 13,29	16	168	48	120	30	92	10036724 (M4x0,5LH/RHx6,5)	30026294 (GR - 2F)	10036752 (M4x4)	30026266 (GR - 2)
13,30 - 14,29	16	168	48	120	30	92	10036725 (M4x0,5LH/RHx9)	30026296 (GR - 2N)	10036753 (M4x5)	30026266 (GR - 2)
14,30 - 15,79	20	170	50	120	30	92	10036725 (M4x0,5LH/RHx9)	30026296 (GR - 2N)	10036753 (M4x5)	30026266 (GR - 2)
15,80 - 17,79	20	170	50	120	30	92	10036725 (M4x0,5LH/RHx9)	30026296 (GR - 2N)	10036753 (M4x5)	30026266 (GR - 2)
17,80 - 18,29	20	170	50	120	30	92	10036725 (M4x0,5LH/RHx9)	30026296 (GR - 2N)	10036753 (M4x5)	30026266 (GR - 2)
18,30 - 19,79	20	170	50	120	30	92	10036725 (M4x0,5LH/RHx9)	30026296 (GR - 2N)	10036754 (M4x6)	30026266 (GR - 2)
19,80 - 24,79	20	170	50	120	30	92	10036725 (M4x0,5LH/RHx9)	30026296 (GR - 2N)	10036755 (M4x8)	30026266 (GR - 2)
24,80 - 29,29	20	170	50	120	30	93	10036725 (M4x0,5LH/RHx9)	30026298 (GR - 3N)	10036761 (M6x10)	30026279 (GR - 4)
28,80 - 30,79	20	170	50	120	30	93	10036725 (M4x0,5LH/RHx9)	30026298 (GR - 3N)	10036762 (M6x12)	30026279 (GR - 4)

Esempio di ordine (vedere pag. 480):

MN2023 HM 20,99 H7 AS

Misure in mm.

Ulteriori dimensioni disponibili su richiesta.

Per le indicazioni sulla regolazione e per il montaggio dei componenti accessori vedere il capitolo "Allegato tecnico".

* I valori non indicano il range di regolazione, bensì le dimensioni costruttive per i diversi diametri (regolabile solo nei limiti del range di tolleranza).

Al momento dell'ordine indicare la qualità desiderata per i pattini di guida (metallo duro, cermet).

In mancanza di indicazioni al riguardo, i pattini di guida verranno realizzati in metallo duro. Utensili con pattini di guida in qualità PCD disponibili a partire da Ø 8 mm.

Riparazioni per motivi tecnici possibili a partire da Ø 8.00

Prezzo e tempi di consegna per utensili con pattini di guida in qualità PCD su richiesta.

Inseriti a fissaggio meccanico idonei da pagina 494.

Alesatore WP a un tagliente MN2024

Struttura costruttiva NC

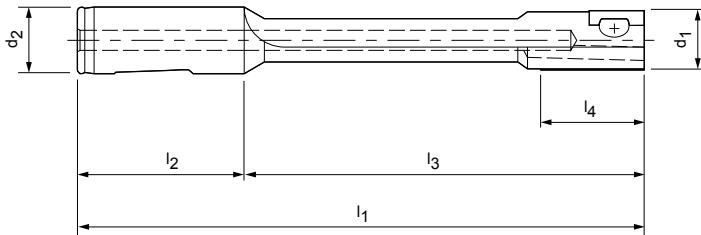

Dimensioni							Accessori			
d ₁ *	d ₂ (-0,003)	l ₁	l ₂	l ₃	l ₄	Dimensione dell'inserto	Serraggio		Regolazione	
							Grano a doppio effetto MN 618	Staffa di serraggio	Grano filettato MN 620	Cuneo di regolazione MN 619
							Codice (dimensione)			
7,80 - 8,29	16	133	48	85	30	90	10036711 (M3LH/RHx5)	30026291 (GR - OZ)	10036743 (M3x2,5)	30026238 (GR - 0)
8,30 - 8,79	16	133	48	85	30	90	10036711 (M3LH/RHx5)	30026291 (GR - OZ)	10036744 (M3x3)	30026238 (GR - 0)
8,80 - 9,29	16	133	48	85	30	90	10036711 (M3LH/RHx5)	30026291 (GR - OZ)	10036744 (M3x3)	30026238 (GR - 0)
9,30 - 11,29	16	133	48	85	30	90	10036722 (M3LH/RHx6)	30026289 (GR - ON)	10036744 (M3x3)	30026263 (GR - 1)
11,30 - 11,79	16	133	48	85	30	90	10036722 (M3LH/RHx6)	30026289 (GR - ON)	10036745 (M3x4)	30026263 (GR - 1)
11,80 - 12,29	16	168	48	120	30	90	10036722 (M3LH/RHx6)	30026289 (GR - ON)	10036745 (M3x4)	30026263 (GR - 1)
12,30 - 14,29	16	168	48	120	30	91	10036722 (M3LH/RHx6)	30026292 (GR - 1N)	10036745 (M3x4)	30026263 (GR - 1)
14,30 - 16,29	20	170	50	120	30	91	10036722 (M3LH/RHx6)	30026292 (GR - 1N)	10036747 (M3x6)	30026263 (GR - 1)
16,30 - 17,29	20	170	50	120	30	92	10036725 (M4x0,5LH/RHx9)	30026296 (GR - 2N)	10036753 (M4x5)	30026266 (GR - 2)
17,30 - 19,79	20	170	50	120	30	92	10036725 (M4x0,5LH/RHx9)	30026296 (GR - 2N)	10036754 (M4x6)	30026266 (GR - 2)
19,80 - 20,79	20	170	50	120	30	92	10036725 (M4x0,5LH/RHx9)	30026296 (GR - 2N)	10036755 (M4x8)	30026266 (GR - 2)

Esempio di ordine (vedere pag. 480):
MN2024 HM 11,99 H7 AS

Misure in mm.

Ulteriori dimensioni disponibili su richiesta.

Per le indicazioni sulla regolazione e per il montaggio dei componenti accessori vedere il capitolo "Allegato tecnico".

* I valori non indicano il range di regolazione, bensì le dimensioni costruttive per i diversi diametri (regolabile solo nei limiti del range di tolleranza).

Al momento dell'ordine indicare la qualità desiderata per i pattini di guida (metallo duro, cermet).

In mancanza di indicazioni al riguardo, i pattini di guida verranno realizzati in metallo duro.

Utensili con pattini di guida in qualità PCD disponibili a partire da Ø 8 mm.

Riparazioni per motivi tecnici possibili a partire da Ø 8.00

Prezzo e tempi di consegna per utensili con pattini di guida in qualità PCD su richiesta.

Inserti a fissaggio meccanico idonei da pagina 494.

Alesatore WP a un tagliente MN2043

Struttura costruttiva NC

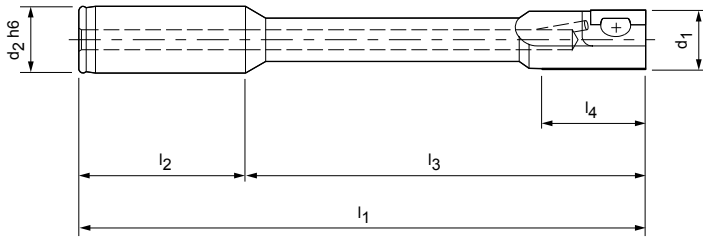

Dimensioni							Accessori			
d ₁ *	d ₂ h6	l ₁	l ₂	l ₃	l ₄	Dimensione dell'inserito	Serraggio		Regolazione	
							Grano a doppio effetto MN 618	Staffa di serraggio	Grano filettato MN 620	Cuneo di regolazione MN 619
							Codice (dimensione)			
7,80 - 8,29	16	133	48	85	30	90	10036711 (M3LH/RHx5)	30026288 (GR - 0F)	10036743 (M3x2,5)	30026238 (GR - 0)
8,30 - 8,79	16	133	48	85	30	90	10036711 (M3LH/RHx5)	30026288 (GR - 0F)	10036744 (M3x3)	30026238 (GR - 0)
8,80 - 9,29	16	133	48	85	30	90	10036711 (M3LH/RHx5)	30026289 (GR - 0N)	10036744 (M3x3)	30026238 (GR - 0)
9,30 - 11,29	16	133	48	85	30	91	10036722 (M3LH/RHx6)	30026292 (GR - 1N)	10036744 (M3x3)	30026263 (GR - 1)
11,30 - 11,79	16	133	48	85	30	92	10036724 (M4x0,5LH/RHx6,5)	30026294 (GR - 2F)	10036751 (M4x3)	30026266 (GR - 2)
11,80 - 12,29	16	168	48	120	30	92	10036724 (M4x0,5LH/RHx6,5)	30026294 (GR - 2F)	10036751 (M4x3)	30026266 (GR - 2)
12,30 - 13,29	16	168	48	120	30	92	10036724 (M4x0,5LH/RHx6,5)	30026294 (GR - 2F)	10036752 (M4x4)	30026266 (GR - 2)
13,30 - 14,29	16	168	48	120	30	92	10036725 (M4x0,5LH/RHx9)	30026296 (GR - 2N)	10036753 (M4x5)	30026266 (GR - 2)
14,30 - 15,79	20	170	50	120	30	92	10036725 (M4x0,5LH/RHx9)	30026296 (GR - 2N)	10036753 (M4x5)	30026266 (GR - 2)
15,80 - 17,79	20	170	50	120	30	92	10036725 (M4x0,5LH/RHx9)	30026296 (GR - 2N)	10036753 (M4x5)	30026266 (GR - 2)
17,80 - 18,29	20	170	50	120	30	92	10036725 (M4x0,5LH/RHx9)	30026296 (GR - 2N)	10036753 (M4x5)	30026266 (GR - 2)
18,30 - 19,79	20	170	50	120	30	92	10036725 (M4x0,5LH/RHx9)	30026296 (GR - 2N)	10036754 (M4x6)	30026266 (GR - 2)
19,80 - 24,79	20	170	50	120	30	92	10036725 (M4x0,5LH/RHx9)	30026296 (GR - 2N)	10036755 (M4x8)	30026266 (GR - 2)
24,80 - 28,79	20	170	50	120	30	93	10036725 (M4x0,5LH/RHx9)	30026298 (GR - 3N)	10036761 (M6x10)	30026279 (GR - 4)
28,80 - 31,79	20	170	50	120	30	93	10036725 (M4x0,5LH/RHx9)	30026298 (GR - 3N)	10036762 (M6x12)	30026279 (GR - 4)
31,80 - 37,79	20	170	50	120	30	93	10036725 (M4x0,5LH/RHx9)	30026298 (GR - 3N)	10036764 (M6x15)	30026279 (GR - 4)
37,80 - 40,29	25	176	56	120	30	93	10036725 (M4x0,5LH/RHx9)	30026298 (GR - 3N)	10036764 (M6x15)	30026279 (GR - 4)

Esempio di ordine (vedere pag. 480):
MN2043 HM 20,99 H7 AS

Misure in mm.

Ulteriori dimensioni disponibili su richiesta.

Per le indicazioni sulla regolazione e per il montaggio dei componenti accessori vedere il capitolo "Allegato tecnico".

* I valori non indicano il range di regolazione, bensì le dimensioni costruttive per i diversi diametri (regolabile solo nei limiti del range di tolleranza).

Al momento dell'ordine indicare la qualità desiderata per i pattini di guida (metallo duro, cermet).

In mancanza di indicazioni al riguardo, i pattini di guida verranno realizzati in metallo duro. Utensili con pattini di guida in qualità PCD disponibili a partire da Ø 8 mm.

Riparazioni per motivi tecnici possibili a partire da Ø 8.00

Prezzo e tempi di consegna per utensili con pattini di guida in qualità PCD su richiesta.

Inseriti a fissaggio meccanico idonei da pagina 494.

Alesatore WP a un tagliente MN2044

Struttura costruttiva NC

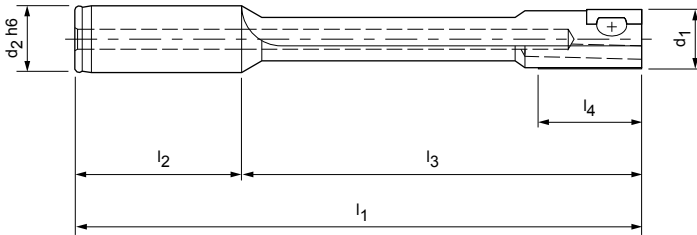

Dimensioni							Accessori			
d ₁ *	d ₂ h6	l ₁	l ₂	l ₃	l ₄	Dimensione dell'inserto	Serraggio		Regolazione	
							Grano a doppio effetto MN 618	Staffa di serraggio	Grano filettato MN 620	Cuneo di regolazione MN 619
Codice (dimensione)										
7,80 - 8,29	16	133	48	85	30	90	10036711 (M3LH/RHx5)	30026291 (GR - OZ)	10036743 (M3x2,5)	30026238 (GR - 0)
8,30 - 8,79	16	133	48	85	30	90	10036711 (M3LH/RHx5)	30026291 (GR - OZ)	10036744 (M3x3)	30026238 (GR - 0)
8,80 - 9,29	16	133	48	85	30	90	10036711 (M3LH/RHx5)	30026291 (GR - OZ)	10036744 (M3x3)	30026238 (GR - 0)
9,30 - 11,29	16	133	48	85	30	90	10036722 (M3LH/RHx6)	30026289 (GR - ON)	10036744 (M3x3)	30026263 (GR - 1)
11,30 - 11,79	16	133	48	85	30	90	10036722 (M3LH/RHx6)	30026289 (GR - ON)	10036745 (M3x4)	30026263 (GR - 1)
11,80 - 12,29	16	168	48	120	30	90	10036722 (M3LH/RHx6)	30026289 (GR - ON)	10036745 (M3x4)	30026263 (GR - 1)
12,30 - 14,29	16	168	48	120	30	91	10036722 (M3LH/RHx6)	30026292 (GR - 1N)	10036745 (M3x4)	30026263 (GR - 1)
14,30 - 16,29	20	170	50	120	30	91	10036722 (M3LH/RHx6)	30026292 (GR - 1N)	10036747 (M3x6)	30026263 (GR - 1)
16,30 - 17,29	20	170	50	120	30	92	10036725 (M4x0,5LH/RHx9)	30026296 (GR - 2N)	10036753 (M4x5)	30026266 (GR - 2)
17,30 - 19,79	20	170	50	120	30	92	10036725 (M4x0,5LH/RHx9)	30026296 (GR - 2N)	10036754 (M4x6)	30026266 (GR - 2)
19,80 - 20,79	20	170	50	120	30	92	10036725 (M4x0,5LH/RHx9)	30026296 (GR - 2N)	10036755 (M4x8)	30026266 (GR - 2)

Esempio di ordine (vedere pag. 480):
MN2044 HM 11,99 H7 AS

Misure in mm.

Ulteriori dimensioni disponibili su richiesta.

Per le indicazioni sulla regolazione e per il montaggio dei componenti accessori vedere il capitolo "Allegato tecnico".

* I valori non indicano il range di regolazione, bensì le dimensioni costruttive per i diversi diametri (regolabile solo nei limiti del range di tolleranza).

Al momento dell'ordine indicare la qualità desiderata per i pattini di guida (metallo duro, cermet).

In mancanza di indicazioni al riguardo, i pattini di guida verranno realizzati in metallo duro. Utensili con pattini di guida in qualità PCD disponibili a partire da Ø 8 mm.

Riparazioni per motivi tecnici possibili a partire da Ø 8.00

Prezzo e tempi di consegna per utensili con pattini di guida in qualità PCD su richiesta.

Inserti a fissaggio meccanico idonei da pagina 494.

Inserti a fissaggio meccanico con imbocco AS

Per utensili con pattini di guida

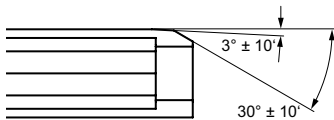

Imbocco AS

Imbocco adatto a tutti i materiali, alta qualità della superficie anche con velocità di taglio elevate. Lunghezza di imbocco 1,3 mm.

Profondità max. di passata assiale: 0,25 mm
Angolo di spoglia: 0°, 6°, 12°

Materiale da taglio	Metallo duro								
GTM*	P			M	K		N		
	1.1 - 1.2	2 - 3 5	P4 P6	1 - 3	1.1	2 - 3	1.1 - 1.2	2.3	2.1 - 2.2
Tipo di materiale da taglio	HP115	HP425	HP016	HP016	HC418	HP426	HP612	HU615	

Angolo di spoglia	Dimensione strutturale	Specifiche	Codice							
negativo	81	SP-AS81R0-...								
	90	SP-AS90R0-...								
	91	SP-AS91R0-...								
	92	SP-AS92R0-...								
	93	SP-AS93R0-...								

neutro	81	SP-AS81R0-...								
	90	WP-AS90R0-...								
	91	WP-AS91R0-...								
	92	WP-AS92R0-...								
	93	WP-AS93R0-...								

positivo	81	SP-AS81R6-...	30669442	30669444	31100866	31100866				30669441	
	90	WP-AS90R6-...	30668837	30668839	31100867	31100867				30668836	
	91	WP-AS91R6-...	30668848	30668850	31080268	31080268				30668847	
	92	WP-AS92R6-...	30668858	30668859	30912087	30912087				30668857	
	93	WP-AS93R6-...	30668869	30250310	30915826	30915826				30668868	

altamente positivo	81	SP-AS81R2-...								30685605		30669437
	90	WP-AS90R2-...								30685606		30668833
	91	WP-AS91R2-...								30685607		30668844
	92	WP-AS92R2-...								30685608		30668853
	93	WP-AS93R2-...								30685609		30668863

Inserti a fissaggio meccanico con imbocco AZ

Per utensili con pattini di guida

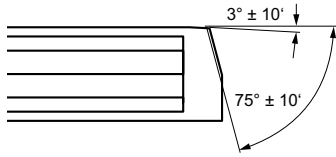

Imbocco AZ

Per velocità di taglio elevate, adatto in particolare alla lavorazione dell'alluminio.

Profondità max. di passata assiale: 0,5 mm
Angolo di spoglia: 0°, 6°, 12°

Materiale da taglio	Metallo duro								
GTM*	P			M	K		N		
	1.1 - 1.2	2 - 3 5	4 6	1 - 3	1.1	2 - 3	1.1 - 1.2	2.3	2.1 - 2.2
Tipo di materiale da taglio	HP115	HP425	HP016	HP016	HC418	HP426	HP612	HU615	

Angolo di spoglia	Dimensione strutturale	Specifiche	Codice							
negativo	81	SP-AZ81R0-...								
	90	SP-AZ90R0-...								
	91	SP-AZ91R0-...								
	92	SP-AZ92R0-...								
	93	SP-AZ93R0-...								

neutro	81	SP-AZ81R0-...					30685624				
	90	WP-AZ90R0-...					30670062				
	91	WP-AZ91R0-...					30685625				
	92	WP-AZ92R0-...					30664930				
	93	WP-AZ93R0-...					30664935				

positivo	81	SP-AZ81R6-...						30914241		30668876	
	90	WP-AZ90R6-...						30914251		30668884	
	91	WP-AZ91R6-...						30914261		30668891	
	92	WP-AZ92R6-...						30914275		30668903	
	93	WP-AZ93R6-...						30914304		30668912	

altamente positivo	81	SP-AZ81R2-...							30685639		30668875
	90	WP-AZ90R2-...							30685640		30668881
	91	WP-AZ91R2-...							30685641		30668889
	92	WP-AZ92R2-...							30685642		30668899
	93	WP-AZ93R2-...							30685643		30668908

* Gruppi di materiale MAPAL



Metallo duro		
S		H
1 - 2		1.1
HU615		HP016

Cermet	
P	
1 - 3 5	
CP122	

PCD	
N	
1 - 2	
PU620	

PcBN		
K		H
1.1		1.1 - 1.2
FU485		FU801

Codice		

Codice	

Codice	

Codice		

Inserti a fissaggio meccanico con imbocco DZ

Per utensili con pattini di guida

Imbocco DZ

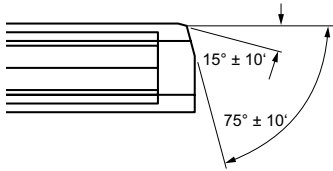

Specifico per materiali a trucioli corti (GG) e grandi profondità di passata assiale. L'angolo di imbocco del tagliente di finitura di 15° aumenta leggermente le forze radiali ed è pertanto adatto anche a elementi con pareti sottili

Profondità max. di passata assiale: 0,15 mm
Angolo di spoglia: 0°, 6°, 12°

Materiale da taglio	Metallo duro								
GTM*	P			M	K		N		
	1.1 - 1.2	2 - 3 5	4 6	1 - 3	1.1	2 - 3	1.1 - 1.2	2.3	2.1 - 2.2
Tipo di materiale da taglio	HP115	HP425	HP016	HP016	HC418	HP426	HP612	HU615	

Angolo di spoglia	Dimensione strutturale	Specifiche	Codice							
negativo	81	SP-DZ81R0-...								
	90	SP-DZ90R0-...								
	91	SP-DZ91R0-...								
	92	SP-DZ92R0-...								
	93	SP-DZ93R0-...								

neutro	81	SP-DZ81R0-...					30685653				
	90	WP-DZ90R0-...					30685654				
	91	WP-DZ91R0-...					30664932				
	92	WP-DZ92R0-...					30685655				
	93	WP-DZ93R0-...					30667699				

positivo	81	SP-DZ81R6-...	30668927	30668928	31090592	31090592		30914351		30668926	
	90	WP-DZ90R6-...	30668936	30668785	31034657	31034657		30914370		30668935	
	91	WP-DZ91R6-...	30668949	30668950	31028496	31028496		30914400		30668947	
	92	WP-DZ92R6-...	30668960	30668961	31100878	31100878		30914435		30668959	
	93	WP-DZ93R6-...	30668969	30668970	31069730	31069730		30914474		30668968	

altamente positivo	81	SP-DZ81R2-...								30685663		30668923
	90	WP-DZ90R2-...								30685664		30668933
	91	WP-DZ91R2-...								30685665		30668942
	92	WP-DZ92R2-...								30685666		30668956
	93	WP-DZ93R2-...								30685667		30668965

* Gruppi di materiale MAPAL

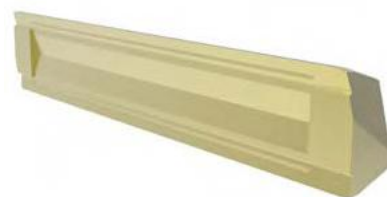

Metallo duro	
S	H
1 - 2	1.1
HU615	HP016

Cermet	
P	
1 - 3 5	
CP122	

PCD	
N	
1 - 2	
PU620	

PcBN	
K	H
1.1	1.1 - 1.2
FU485	FU801

Codice	

Codice	

Codice	

Codice	
30262157**	30011418**
30490660**	30020729**
30174899**	30669469**
30502436**	30669472**

	31090592
	31034657
	31028496
	31100878
	31069730

	30773222
	30668948
	30314334
	30895254

	30669224**
	30669464**
	30669467**
	30669471**
	30669473**

	30668923
	30668933
	30668942
	30668956
	30668965

Inserti a fissaggio meccanico con imbocco EK

Per utensili con pattini di guida

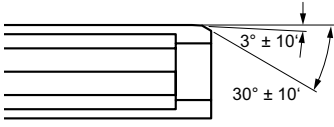

Imbocco EK

Da utilizzarsi solo quando è richiesta una lunghezza di imbocco ridotta pari a 0,6 mm. Adatto a tutti i materiali, non superare avanzamento max. pari a 0,2 mm/giri.

Profondità max. di passata assiale: 0,15 mm
Angolo di spoglia: 0°, 6°, 12°

Materiale da taglio	Metallo duro								
GTM*	P			M	K		N		
	1.1 - 1.2	2 - 3 5	4 6	1 - 3	1.1	2 - 3	1.1 - 1.2	2.3	2.1 - 2.2
Tipo di materiale da taglio	HP115	HP425	HP016	HP016	HC418	HP426	HP612	HU615	

Angolo di spoglia	Dimensioni	Specifiche	Codice							
negativo	181	SP-EK181R0-...								
	150	SP-EK150R0-...								
	151	SP-EK151R0-...								
	152	SP-EK152R0-...								
	153	SP-EK153R0-...								

neutro	181	SP-EK181R0-...								
	150	WP-EK150R0-...								
	151	WP-EK151R0-...								
	152	WP-EK152R0-...								
	153	WP-EK153R0-...								

positivo	181	SP-EK181R6-...	30681706	30681707	31100872	31100872				30681705	
	150	WP-EK150R6-...	30668978	30668979	31100873	31100873				30668977	
	151	WP-EK151R6-...	30668987	30389077	31049120	31049120				30668986	
	152	WP-EK152R6-...	30668999	30669000	30990556	30990556				30668998	
	153	WP-EK153R6-...	30669009	30669010	31100874	31100874				30669008	

altamente positivo	181	SP-EK181R2-...								30685689		30681702
	150	WP-EK150R2-...								30685690		30668974
	151	WP-EK151R2-...								30685691		30668983
	152	WP-EK152R2-...								30685692		30668993
	153	WP-EK153R2-...								30685693		30669006

Inserti a fissaggio meccanico con imbocco SZ

Per utensili con pattini di guida

Imbocco SZ

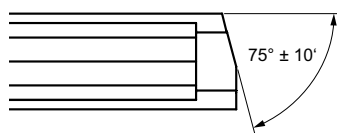

Specifico per leghe di alluminio pressofuso, ottima superficie su piccoli avanzamenti. I profili vengono rispettati con precisione. L'angolo di imbocco del tagliente principale di 75° riduce le forze radiali ed è pertanto particolarmente adatto a elementi con pareti sottili.

Profondità max. di passata assiale: 1,00 mm
Angolo di spoglia: 6°, 12°

Materiale da taglio	Metallo duro									
GTM*	P			M	K			N		
	1.1 - 1.2	2 - 3 5	4 6	1 - 3	1.1	2 - 3	1.1 - 1.2	2.3	2.1 - 2.2	
Tipo di materiale da taglio	HP115	HP425	HP016	HP016	HC418	HP426	HP612	HU615		

Angolo di spoglia	Dimensione strutturale	Specifiche	Codice							
negativo	81	SP-SZ81R0-...								
	90	SP-SZ90R0-...								
	91	SP-SZ91R0-...								
	92	SP-SZ92R0-...								
	93	SP-SZ93R0-...								

neutro	81	SP-SZ81R0-...								
	90	WP-SZ90R0-...								
	91	WP-SZ91R0-...								
	92	WP-SZ92R0-...								
	93	WP-SZ93R0-...								

positivo	81	SP-SZ81R6-...							31306727	30669514
	90	WP-SZ90R6-...							31306729	30669523
	91	WP-SZ91R6-...							31306730	30669534
	92	WP-SZ92R6-...							30690795	30669541
	93	WP-SZ93R6-...							31306732	30669549

altamente positivo	81	SP-SZ81R2-...								30669511
	90	WP-SZ90R2-...								30669520
	91	WP-SZ91R2-...								30669531
	92	WP-SZ92R2-...								30669538
	93	WP-SZ93R2-...								30669546

Parametri di lavorazione consigliati per inserti a fissaggio meccanico con imbocco AS

Avanzamento e velocità di taglio

AS-HP115

GTM*	Materiale	Resistenza/durezza [N/mm ²] [HRC]	Velocità di taglio v_c (m/min)		Avanzamento f_z (mm/z)	
			Adduzione interna del refrigerante	Raffredda- mento esterno		
P P1	P1.1	Acciai da costruzione, automatici, da cementazione e da bonifica, non legati	< 700	80	40	0,150
	P1.2	Acciai da costruzione, automatici, da cementazione e da bonifica, non legati	< 1200	70	35	0,150

AS-HP425

GTM*	Materiale	Resistenza/durezza [N/mm ²] [HRC]	Velocità di taglio v_c (m/min)		Avanzamento f_z (mm/z)	
			Adduzione interna del refrigerante	Raffredda- mento esterno		
P P2 P3 P5	P2.1	Acciai da nitrurazione, da cementazione e da bonifica, legati	< 900	100	50	0,150
	P2.2	Acciai da nitrurazione, da cementazione e da bonifica, legati	< 1400	80	40	0,150
	P3.1	Acciai per utensili, per cuscinetti volventi, armonici e per lavorazioni veloci**	< 900	100	50	0,150
	P3.2	Acciai per utensili, per cuscinetti volventi, armonici e per lavorazioni veloci**	< 1500	80	40	0,150
	P5.1	Acciaio fuso		80	40	0,150

AS-HP016

GTM*	Materiale	Resistenza/durezza [N/mm ²] [HRC]	Velocità di taglio v_c (m/min)		Avanzamento f_z (mm/z)	
			Adduzione interna del refrigerante	Raffredda- mento esterno		
P P4 P6	P4.1	Acciai inossidabili, ferritici e martensitici		50	25	0,120
	P6.1	Acciaio fuso, ferritico e martensitico		40	20	0,120
M M1 M2 M3	M1.1	Acciai inossidabili, austenitici	< 700	50	25	0,120
	M1.2	Acciai inossidabili, ferritici/austenitici (Duplex)	< 1000	30	15	0,120
	M2.1	Acciaio fuso inossidabile, austenitico	< 700	50	25	0,120
M3.1	Acciaio fuso inossidabile, ferritico/austenitico (Duplex)	< 1000	30	15	0,120	

AS-HP612

GTM*	Materiale	Resistenza/durezza [N/mm ²] [HRC]	Velocità di taglio v_c (m/min)		Avanzamento f_z (mm/z)	
			Adduzione interna del refrigerante	Raffredda- mento esterno		
N N1	N1.1	Alluminio, non legato e legato < 3% Si		160	80	0,150
	N1.2	Alluminio, legato ≤ 7% Si		160	80	0,150

* Gruppi di materiale MAPAL

** Qualora la somma dei componenti di lega Cr, Mo, Ni, V, W equivalesse a > 8%, selezionare il gruppo di materiale MAPAL immediatamente superiore.

AS-HU615

GTM*		Materiale	Resistenza/durezza [N/mm ²] [HRC]	Velocità di taglio v _c (m/min)		Avanzamento f _z (mm/z)	
				Adduzione interna del refrigerante	Raffred- damento esterno		
N	N2	N2.1	Rame, non legato e bassolegato	< 300	100	50	0,150
		N2.2	Rame, legato	> 300	100	50	0,150
		N2.3	Ottone, bronzo, ghisa rossa	< 1200	100	50	0,150
S	S1	S1.1	Titanio, leghe di titanio	< 400	30	15	0,120
		S2.1	Titanio, leghe di titanio	< 1200	20	10	0,120
		S2.2	Titanio, leghe di titanio	> 1200	20	10	0,100

AS-CP122

GTM*		Materiale	Resistenza/durezza [N/mm ²] [HRC]	Velocità di taglio v _c (m/min)		Avanzamento f _z (mm/z)	
				Adduzione interna del refrigerante	Raffred- damento esterno		
P1	P1	P1.1	Acciai da costruzione, automatici, da cementazione e da bonifica, non legati	< 700	180	90	0,150
		P1.2	Acciai da costruzione, automatici, da cementazione e da bonifica, non legati	< 1200	160	80	0,120
P2	P2	P2.1	Acciai da nitrurazione, da cementazione e da bonifica, legati	< 900	160	80	0,150
		P2.2	Acciai da nitrurazione, da cementazione e da bonifica, legati	< 1400	140	70	0,120
P3	P3	P3.1	Acciai per utensili, per cuscinetti volventi, armonici e per lavorazioni veloci**	< 800	160	80	0,150
		P3.2	Acciai per utensili, per cuscinetti volventi, armonici e per lavorazioni veloci**	< 1000	160	80	0,150
P5	P5	P5.1	Acciaio fuso	< 1500	140	70	0,120
		P5.1	Acciaio fuso		140	70	0,120

AS-PU620

GTM*		Materiale	Resistenza/durezza [N/mm ²] [HRC]	Velocità di taglio v _c (m/min)		Avanzamento f _z (mm/z)	
				Adduzione interna del refrigerante	Raffred- damento esterno		
N	N1	N1.1	Alluminio, non legato e legato < 3% Si		230	115	0,150
		N1.2	Alluminio, legato ≤ 7% Si		230	115	0,150
		N1.3	Alluminio, legato > 7-12% Si		230	115	0,150
		N1.4	Alluminio, legato > 12% Si		230	115	0,150
N2	N2	N2.1	Rame, non legato e bassolegato	< 300	180	90	0,150
		N2.2	Rame, legato	> 300	180	90	0,150
		N2.3	Ottone, bronzo, ghisa rossa	< 1200	180	90	0,150

I parametri di lavorazione indicati sono valori orientativi.

I dati ottimali per la specifica applicazione devono essere rilevati eseguendo diversi tentativi o durante l'effettiva lavorazione.

Parametri di lavorazione consigliati per inserti a fissaggio meccanico con imbocco AZ

Avanzamento e velocità di taglio

AZ-HC418

GTM*	Materiale	Resistenza/durezza [N/mm ²] [HRC]	Velocità di taglio v_c (m/min)		Avanzamento f_z (mm/z)
			Adduzione interna del refrigerante	Raffredda- mento esterno	
K K1 K1.1	Ghisa con grafite lamellare (ghisa grigia), GJL	< 300	110	55	0,150

AZ-HP426

GTM*	Materiale	Resistenza/durezza [N/mm ²] [HRC]	Velocità di taglio v_c (m/min)		Avanzamento f_z (mm/z)
			Adduzione interna del refrigerante	Raffredda- mento esterno	
K K2	K2.1 Ghisa con grafite sferoidale, GJS	< 500	110	55	0,150
	K2.2 Ghisa con grafite sferoidale, GJS	≤ 800	100	50	0,150
	K2.3 Ghisa con grafite sferoidale, GJS	> 800	80	40	0,150
K K3	K3.1 Ghisa con grafite vermicolare, GJV; acciaio fuso malleabile, GJM	< 500	80	40	0,150
	K3.2 Ghisa con grafite vermicolare, GJV; acciaio fuso malleabile, GJM	> 500	80	40	0,150

AZ-HP612

GTM*	Materiale	Resistenza/durezza [N/mm ²] [HRC]	Velocità di taglio v_c (m/min)		Avanzamento f_z (mm/z)
			Adduzione interna del refrigerante	Raffredda- mento esterno	
N N1	N1.1 Alluminio, non legato e legato < 3% Si		160	80	0,150
	N1.2 Alluminio, legato ≤ 7% Si		160	80	0,150

AZ-HU615

GTM*	Materiale	Resistenza/durezza [N/mm ²] [HRC]	Velocità di taglio v_c (m/min)		Avanzamento f_z (mm/z)
			Adduzione interna del refrigerante	Raffredda- mento esterno	
N2	N2.1 Rame, non legato e bassolegato	< 300	110	55	0,150
	N2.2 Rame, legato	> 300	110	55	0,150
	N2.3 Ottone, bronzo, ghisa rossa	< 1200	110	55	0,150

AZ-PU620

GTM*	Materiale	Resistenza/durezza [N/mm ²] [HRC]	Velocità di taglio v _c (m/min)		Avanzamento f _z (mm/z)	
			Adduzione interna del refrigerante	Raffredda- mento esterno		
N	N1	N1.1 Alluminio, non legato e legato < 3% Si		230	115	0,150
		N1.2 Alluminio, legato ≤ 7% Si		230	115	0,150
		N1.3 Alluminio, legato > 7-12% Si		230	115	0,150
		N1.4 Alluminio, legato > 12% Si		230	115	0,150
	N2	N2.1 Rame, non legato e bassolegato	< 300	180	90	0,150
		N2.2 Rame, legato	> 300	180	90	0,150
		N2.3 Ottone, bronzo, ghisa rossa	< 1200	180	90	0,150

AZ-FU485

GTM*	Materiale	Resistenza/durezza [N/mm ²] [HRC]	Velocità di taglio v _c (m/min)		Avanzamento f _z (mm/z)
			Adduzione interna del refrigerante	Raffredda- mento esterno	
K K1	K1.1 Ghisa con grafite lamellare (ghisa grigia), GJL	< 300	160	80	0,150

I parametri di lavorazione indicati sono valori orientativi.

I dati ottimali per la specifica applicazione devono essere rilevati eseguendo diversi tentativi o durante l'effettiva lavorazione.

Parametri di lavorazione consigliati per inserti a fissaggio meccanico con imbocco DZ

Avanzamento e velocità di taglio

DZ-HP115

GTM*	Materiale	Resistenza/durezza [N/mm ²] [HRC]	Velocità di taglio v_c (m/min)		Avanzamento f_z (mm/z)	
			Adduzione interna del refrigerante	Raffredda- mento esterno		
P P1	P1.1	Acciai da costruzione, automatici, da cementazione e da bonifica, non legati	< 700	80	40	0,150
	P1.2	Acciai da costruzione, automatici, da cementazione e da bonifica, non legati	< 1200	70	35	0,150

DZ-HP425

GTM*	Materiale	Resistenza/durezza [N/mm ²] [HRC]	Velocità di taglio v_c (m/min)		Avanzamento f_z (mm/z)	
			Adduzione interna del refrigerante	Raffredda- mento esterno		
P P2 P3 P5	P2.1	Acciai da nitrurazione, da cementazione e da bonifica, legati	< 900	100	50	0,150
	P2.2	Acciai da nitrurazione, da cementazione e da bonifica, legati	< 1400	80	40	0,150
	P3.1	Acciai per utensili, per cuscinetti volventi, armonici e per lavorazioni veloci**	< 900	100	50	0,150
	P3.2	Acciai per utensili, per cuscinetti volventi, armonici e per lavorazioni veloci**	< 1500	80	40	0,150
	P5.1	Acciaio fuso		80	40	0,150

DZ-HP016

GTM*	Materiale	Resistenza/durezza [N/mm ²] [HRC]	Velocità di taglio v_c (m/min)		Avanzamento f_z (mm/z)	
			Adduzione interna del refrigerante	Raffredda- mento esterno		
P P4 P6	P4.1	Acciai inossidabili, ferritici e martensitici		50	25	0,120
	P6.1	Acciaio fuso, ferritico e martensitico		40	20	0,120
M M1 M2 M3	M1.1	Acciai inossidabili, austenitici	< 700	50	25	0,120
	M1.2	Acciai inossidabili, ferritici/austenitici (Duplex)	< 1000	30	15	0,120
	M2.1	Acciaio fuso inossidabile, austenitico	< 700	50	25	0,120
M3.1	Acciaio fuso inossidabile, ferritico/austenitico (Duplex)	< 1000	30	15	0,120	

DZ-HC418

GTM*	Materiale	Resistenza/durezza [N/mm ²] [HRC]	Velocità di taglio v_c (m/min)		Avanzamento f_z (mm/z)	
			Adduzione interna del refrigerante	Raffredda- mento esterno		
K K1	K1.1	Ghisa con grafite lamellare (ghisa grigia), GJL	< 300	100	50	0,150

* Gruppi di materiale MAPAL

** Qualora la somma dei componenti di lega Cr, Mo, Ni, V, W equivalesse a > 8%, selezionare il gruppo di materiale MAPAL immediatamente superiore.

DZ-HP426

GTM*	Materiale	Resistenza/durezza [N/mm ²] [HRC]	Velocità di taglio v _c (m/min)		Avanzamento f _z (mm/z)
			Adduzione interna del refrigerante	Raffredda- mento esterno	
K2	K2.1 Ghisa con grafite sferoidale, GJS	< 500	100	50	0,150
	K2.2 Ghisa con grafite sferoidale, GJS	≤ 800	90	45	0,150
	K2.3 Ghisa con grafite sferoidale, GJS	> 800	80	40	0,150
K3	K3.1 Ghisa con grafite vermicolare, GJV; acciaio fuso malleabile, GJM	< 500	70	35	0,150
	K3.2 Ghisa con grafite vermicolare, GJV; acciaio fuso malleabile, GJM	> 500	70	35	0,150

DZ-HP612

GTM*	Materiale	Resistenza/durezza [N/mm ²] [HRC]	Velocità di taglio v _c (m/min)		Avanzamento f _z (mm/z)
			Adduzione interna del refrigerante	Raffredda- mento esterno	
N N1	N1.1 Alluminio, non legato e legato < 3% Si		160	80	0,150
	N1.2 Alluminio, legato ≤ 7% Si		160	80	0,150

DZ-HU615

GTM*	Materiale	Resistenza/durezza [N/mm ²] [HRC]	Velocità di taglio v _c (m/min)		Avanzamento f _z (mm/z)
			Adduzione interna del refrigerante	Raffredda- mento esterno	
N N2	N2.1 Rame, non legato e bassolegato	< 300	100	50	0,150
	N2.2 Rame, legato	> 300	100	50	0,150
	N2.3 Ottone, bronzo, ghisa rossa	< 1200	100	50	0,150
S S1 S2	S1.1 Titanio, leghe di titanio	< 400	30	15	0,120
	S2.1 Titanio, leghe di titanio	< 1200	20	10	0,120
	S2.2 Titanio, leghe di titanio	> 1200	20	10	0,100

DZ-HP016

GTM*	Materiale	Resistenza/durezza [N/mm ²] [HRC]	Velocità di taglio v _c (m/min)		Avanzamento f _z (mm/z)
			Adduzione interna del refrigerante	Raffredda- mento esterno	
H H1 H1.1	Acciaio temprato/acciaio fuso	45 - 55	30	15	0,12

I parametri di lavorazione indicati sono valori orientativi.

I dati ottimali per la specifica applicazione devono essere rilevati eseguendo diversi tentativi o durante l'effettiva lavorazione.

Parametri di lavorazione consigliati per inserti a fissaggio meccanico con imbocco DZ

Avanzamento e velocità di taglio

DZ-CP122

GTM*	Materiale	Resistenza/durezza [N/mm ²] [HRC]	Velocità di taglio v _c (m/min)		Avanzamento f _z (mm/z)	
			Adduzione interna del refrigerante	Raffredda- mento esterno		
P1	P1.1	Acciai da costruzione, automatici, da cementazione e da bonifica, non legati	< 700	180	80	0,150
	P1.2	Acciai da costruzione, automatici, da cementazione e da bonifica, non legati	< 1200	160	80	0,120
P2	P2.1	Acciai da nitrurazione, da cementazione e da bonifica, legati	< 900	160	80	0,150
	P2.2	Acciai da nitrurazione, da cementazione e da bonifica, legati	< 1400	140	70	0,120
P3	P3.1	Acciai per utensili, per cuscinetti volventi, armonici e per lavorazioni veloci**	< 800	160	80	0,150
	P3.2	Acciai per utensili, per cuscinetti volventi, armonici e per lavorazioni veloci**	< 1000	160	80	0,150
	P3.3	Acciai per utensili, per cuscinetti volventi, armonici e per lavorazioni veloci**	< 1500	140	70	0,120
P5	P5.1	Acciaio fuso		140	70	0,120

DZ-PU620

GTM*	Materiale	Resistenza/durezza [N/mm ²] [HRC]	Velocità di taglio v _c (m/min)		Avanzamento f _z (mm/z)	
			Adduzione interna del refrigerante	Raffredda- mento esterno		
N1	N1.1	Alluminio, non legato e legato < 3% Si		230	150	0,15
	N1.2	Alluminio, legato ≤ 7% Si		230	150	0,15
	N1.3	Alluminio, legato > 7-12% Si		230	150	0,15
	N1.4	Alluminio, legato > 12% Si		230	150	0,15
N2	N2.1	Rame, non legato e bassolegato	< 300	180	90	0,15
	N2.2	Rame, legato	> 300	180	90	0,15
	N2.3	Ottone, bronzo, ghisa rossa	< 1200	180	90	0,15

DZ-FU485

GTM*	Materiale	Resistenza/durezza [N/mm ²] [HRC]	Velocità di taglio v _c (m/min)		Avanzamento f _z (mm/z)	
			Adduzione interna del refrigerante	Raffredda- mento esterno		
K K1	K1.1	Ghisa con grafite lamellare (ghisa grigia), GJL	< 300	150	75	0,150

DZ-FU801

GTM*	Materiale	Resistenza/durezza [N/mm ²] [HRC]	Velocità di taglio v _c (m/min)		Avanzamento f _z (mm/z)	
			Adduzione interna del refrigerante	Raffredda- mento esterno		
H H1	H1.1	Acciaio temprato/acciaio fuso	45 - 55	60	30	0,100
	H1.2	Acciaio temprato/acciaio fuso	55 - 64	50	25	0,080

* Gruppi di materiale MAPAL

** Qualora la somma dei componenti di lega Cr, Mo, Ni, V, W equivalesse a > 8%, selezionare il gruppo di materiale MAPAL immediatamente superiore.

Parametri di lavorazione consigliati per inserti a fissaggio meccanico con imbocco EZ

Avanzamento e velocità di taglio

EK-HP115

GTM*	Materiale	Resistenza/durezza [N/mm ²] [HRC]	Velocità di taglio v _c (m/min)		Avanzamento f _z (mm/z)	
			Adduzione interna del refrigerante	Raffredda- mento esterno		
P	P1.1	Acciai da costruzione, automatici, da cementazione e da bonifica, non legati	< 700	80	40	0,150
	P1.2	Acciai da costruzione, automatici, da cementazione e da bonifica, non legati	< 1200	70	35	0,150

EK-HP425

GTM*	Materiale	Resistenza/durezza [N/mm ²] [HRC]	Velocità di taglio v _c (m/min)		Avanzamento f _z (mm/z)	
			Adduzione interna del refrigerante	Raffredda- mento esterno		
P	P2.1	Acciai da niturazione, da cementazione e da bonifica, legati	< 900	100	50	0,150
	P2.2	Acciai da niturazione, da cementazione e da bonifica, legati	< 1400	80	40	0,150
	P3.1	Acciai per utensili, per cuscinetti volventi, armonici e per lavorazioni veloci**	< 900	100	50	0,150
	P3.2	Acciai per utensili, per cuscinetti volventi, armonici e per lavorazioni veloci**	< 1500	80	40	0,150
	P5.1	Acciaio fuso		80	40	0,150

EK-HP016

GTM*	Materiale	Resistenza/durezza [N/mm ²] [HRC]	Velocità di taglio v _c (m/min)		Avanzamento f _z (mm/z)	
			Adduzione interna del refrigerante	Raffredda- mento esterno		
P4	P4.1	Acciai inossidabili, ferritici e martensitici		50	25	0,120
	P6.1	Acciaio fuso, ferritico e martensitico		40	20	0,120
M	M1.1	Acciai inossidabili, austenitici	< 700	50	25	0,120
	M1.2	Acciai inossidabili, ferritici/austenitici (Duplex)	< 1000	30	15	0,120
	M2.1	Acciaio fuso inossidabile, austenitico	< 700	50	25	0,120
	M3.1	Acciaio fuso inossidabile, ferritico/austenitico (Duplex)	< 1000	30	15	0,120

EK-HP612

GTM*	Materiale	Resistenza/durezza [N/mm ²] [HRC]	Velocità di taglio v _c (m/min)		Avanzamento f _z (mm/z)	
			Adduzione interna del refrigerante	Raffredda- mento esterno		
N	N1.1	Alluminio, non legato e legato < 3% Si		160	80	0,15
	N1.2	Alluminio, legato ≤ 7% Si		160	80	0,15

I parametri di lavorazione indicati sono valori orientativi.

I dati ottimali per la specifica applicazione devono essere rilevati eseguendo diversi tentativi o durante l'effettiva lavorazione.

Parametri di lavorazione consigliati per inserti a fissaggio meccanico con imbocco EZ

Avanzamento e velocità di taglio

EK-HU615

GTM*		Materiale	Resistenza/durezza [N/mm ²] [HRC]	Velocità di taglio v _c (m/min)		Avanzamento f _z (mm/z)	
				Adduzione interna del refrigerante	Raffredda- mento esterno		
N	N2	N2.1	Rame, non legato e bassolegato	< 300	100	50	0,150
		N2.2	Rame, legato	> 300	100	50	0,150
		N2.3	Ottone, bronzo, ghisa rossa	< 1200	100	50	0,150
S	S1	S1.1	Titanio, leghe di titanio	< 400	30	15	0,120
		S2.1	Titanio, leghe di titanio	< 1200	20	10	0,120
		S2.2	Titanio, leghe di titanio	> 1200	20	10	0,100

EK-CP122

GTM*		Materiale	Resistenza/durezza [N/mm ²] [HRC]	Velocità di taglio v _c (m/min)		Avanzamento f _z (mm/z)	
				Adduzione interna del refrigerante	Raffredda- mento esterno		
P	P1	P1.1	Acciai da costruzione, automatici, da cementazione e da bonifica, non legati	< 700	180	90	0,150
		P1.2	Acciai da costruzione, automatici, da cementazione e da bonifica, non legati	< 1200	160	80	0,120
	P2	P2.1	Acciai da nitrurazione, da cementazione e da bonifica, legati	< 900	160	80	0,150
		P2.2	Acciai da nitrurazione, da cementazione e da bonifica, legati	< 1400	140	70	0,120
	P3	P3.1	Acciai per utensili, per cuscinetti volventi, armonici e per lavorazioni veloci**	< 800	160	80	0,150
		P3.2	Acciai per utensili, per cuscinetti volventi, armonici e per lavorazioni veloci**	< 1000	160	80	0,150
		P3.3	Acciai per utensili, per cuscinetti volventi, armonici e per lavorazioni veloci**	< 1500	140	70	0,120
	P5	P5.1	Acciaio fuso		140	70	0,120

EK-PU620

GTM*		Materiale	Resistenza/durezza [N/mm ²] [HRC]	Velocità di taglio v _c (m/min)		Avanzamento f _z (mm/z)	
				Adduzione interna del refrigerante	Raffredda- mento esterno		
N	N1	N1.1	Alluminio, non legato e legato < 3% Si		230	115	0,150
		N1.2	Alluminio, legato ≤ 7% Si		230	115	0,150
		N1.3	Alluminio, legato > 7-12% Si		230	115	0,150
		N1.4	Alluminio, legato > 12% Si		230	115	0,150
	N2	N2.1	Rame, non legato e bassolegato	< 300	180	90	0,150
		N2.2	Rame, legato	> 300	180	90	0,150
		N2.3	Ottone, bronzo, ghisa rossa	< 1200	180	90	0,150

* Gruppi di materiale MAPAL

** Qualora la somma dei componenti di lega Cr, Mo, Ni, V, W equivalesse a > 8%, selezionare il gruppo di materiale MAPAL immediatamente superiore.

Parametri di lavorazione consigliati per inserti a fissaggio meccanico con imbocco SZ

Avanzamento e velocità di taglio

SZ-HP612

GTM*	Materiale	Resistenza/durezza [N/mm ²] [HRC]	Velocità di taglio v_c (m/min)		Avanzamento f_z (mm/z)
			Adduzione interna del refrigerante	Raffredda- mento esterno	
N N1	N1.1 Alluminio, non legato e legato < 3% Si		160	80	0,120
	N1.2 Alluminio, legato ≤ 7% Si		160	80	0,120

SZ-HU615

GTM*	Materiale	Resistenza/durezza [N/mm ²] [HRC]	Velocità di taglio v_c (m/min)		Avanzamento f_z (mm/z)
			Adduzione interna del refrigerante	Raffredda- mento esterno	
N2	N2.1 Rame, non legato e bassolegato	< 300	100	50	0,120
	N2.2 Rame, legato	> 300	100	50	0,120
	N2.3 Ottone, bronzo, ghisa rossa	< 1200	100	50	0,120

SZ-PU620

GTM*	Materiale	Resistenza/durezza [N/mm ²] [HRC]	Velocità di taglio v_c (m/min)		Avanzamento f_z (mm/z)	
			Adduzione interna del refrigerante	Raffredda- mento esterno		
N	N1	N1.1 Alluminio, non legato e legato < 3% Si		230	115	0,120
		N1.2 Alluminio, legato ≤ 7% Si		230	115	0,120
		N1.3 Alluminio, legato > 7-12% Si		230	115	0,120
		N1.4 Alluminio, legato > 12% Si		230	115	0,120
	N2	N2.1 Rame, non legato e bassolegato	< 300	180	90	0,120
		N2.2 Rame, legato	> 300	180	90	0,120
		N2.3 Ottone, bronzo, ghisa rossa	< 1200	180	90	0,120

I parametri di lavorazione indicati sono valori orientativi.

I dati ottimali per la specifica applicazione devono essere rilevati eseguendo diversi tentativi o durante l'effettiva lavorazione.



Sistema EasyAdjust

Semplice presettaggio di utensili in brevissimo tempo

L'obiettivo primario perseguito con lo sviluppo del sistema EasyAdjust risiede nella drastica riduzione dei costi di regolazione per gli utensili dotati di tecnologia a pattini di guida.

Fulcro del sistema EasyAdjust è un'innovativa cartuccia, che ospita gli inserti a sei o quattro taglienti garantendo stabilità e assenza di gioco. La rastremazione del tagliente secondario è già integrata nella cartuccia, riducendo così i costi di regolazione.

La rastremazione rimane invariata anche durante l'impostazione del diametro, grazie alla guida esatta della cartuccia su di un perno guida di precisione. Sono disponibili cartucce idonee per le diverse rastremazioni. È possibile

scegliere a seconda dell'applicazione specifica, a prescindere dall'inserto a fissaggio meccanico e dall'utensile.

Notevoli vantaggi economici

Nell'applicazione pratica, questo sistema porta notevoli vantaggi alla redditività. Gli inserti a fissaggio meccanico HX, muniti di sei taglienti utili, possono essere impiegati in cartucce con diverse rastremazioni, in modo rapido e preciso. Con il sistema EasyAdjust, gli utensili dovranno essere impostati solo nel diametro. In questo modo si incrementa la sicurezza dei processi nel caso di cambio dei taglienti. Un vantaggio che risulta tanto più evidente quanto più sono numerosi i taglienti dell'utensile. Anche il tempo e il costo neces-

sario alla regolazione di ogni tagliente vengono notevolmente ridotti grazie a questa nuova evoluzione.

VANTAGGI

- Massiccia riduzione degli oneri di regolazione
- Gli utensili dovranno essere impostati solo nel diametro
- Notevole aumento della redditività, della semplicità di utilizzo e della sicurezza dei processi rispetto a utensili con pattini di guida senza sistema EA
- L'elevata precisione resta immutata

Riepilogo sistema

Il sistema EasyAdjust nel dettaglio



Il sistema EasyAdjust è composto da una cartuccia di precisione che accoglie l'inserto a fissaggio meccanico. Per mezzo di un perno guida di precisione, la cartuccia viene guidata in fase di regolazione. La tenuta sicura dell'inserto a fissaggio meccanico è assicurata da una speciale tacca di serraggio, che unitamente alla staffa di serraggio forma un sistema stabile ad accoppiamento di forza.

Con il sistema EasyAdjust, gli utensili dovranno essere impostati solo nel diametro. La rastremazione è già integrata nella cartuccia e resta invariata in caso di modifiche del diametro.

VANTAGGI

- Tempi di regolazione dimezzati
- Guida esatta del sistema su perno guida di precisione
- Rastremazione già integrata nella cartuccia
- Sfruttamento ottimale del materiale da taglio grazie ad inserti a fissaggio meccanico a quattro e sei taglienti

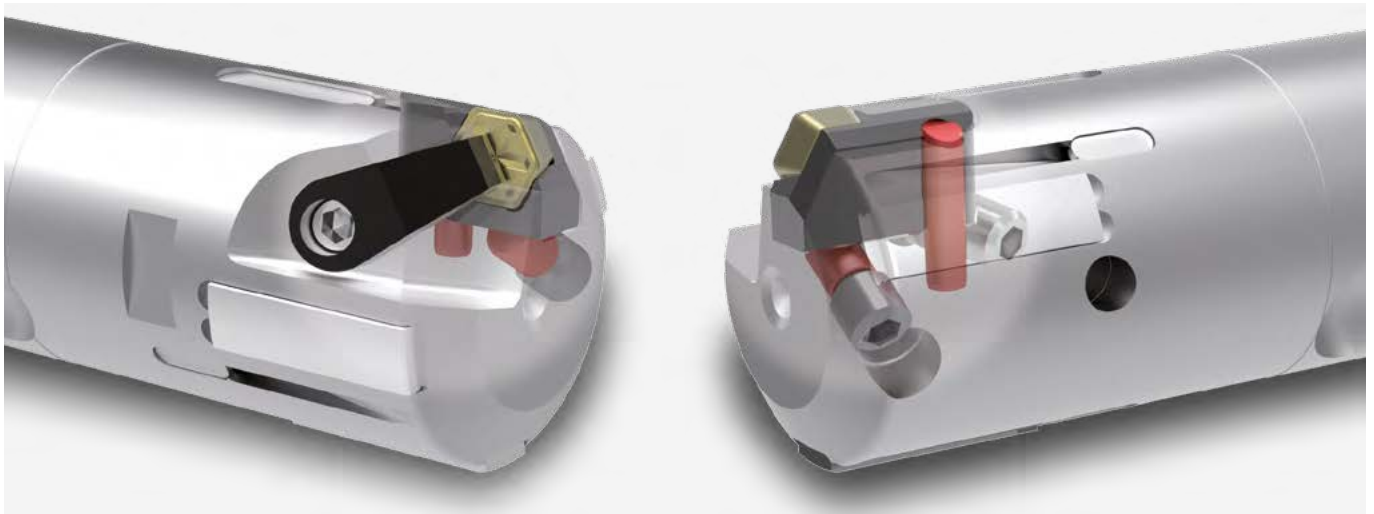

Confronto dei tempi di regolazione

Il sistema EasyAdjust consente di ridurre in maniera massiccia il tempo e il costo necessari alla regolazione di ogni tagliente.

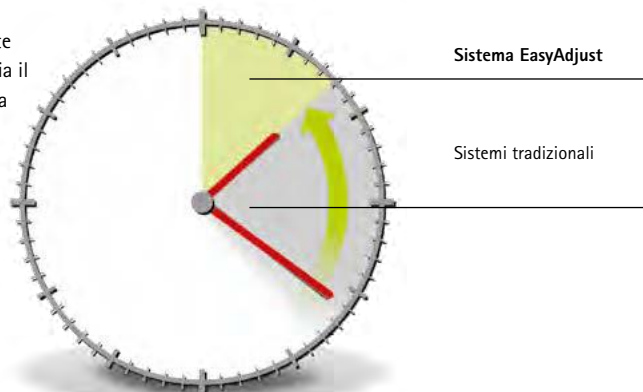

Rastremazione dei taglienti

La rastremazione del tagliente influisce in modo sostanziale sulla qualità del foro. In base ai requisiti di materiale e avanzamento, MAPAL seleziona la rastremazione dei taglienti della cartuccia necessaria per l'applicazione specifica.

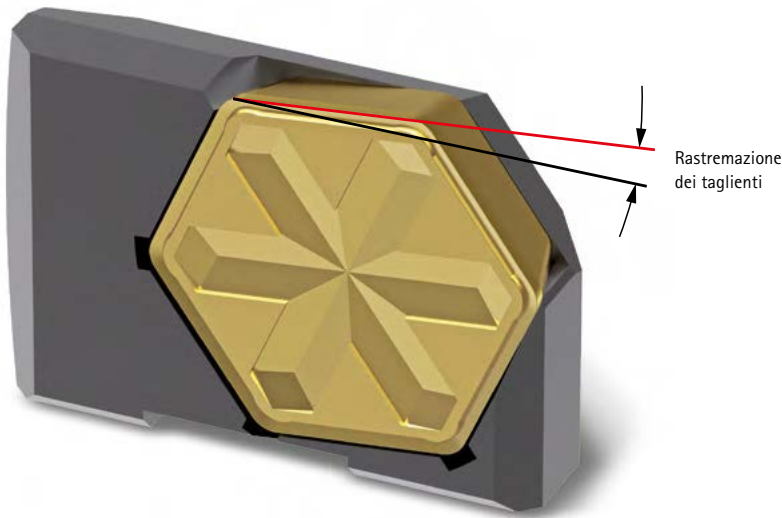

VANTAGGI

- Adattamento della rastremazione indipendente dall'inserto a fissaggio meccanico e dal corpo base dell'utensile
- Realizzazione della ruvidezza predefinita grazie a diverse rastremazioni
- Struttura della superficie ottima per lo svolgimento dei processi seguenti (ad esempio levigatura)

Due varianti di inserto a fissaggio meccanico

Il sistema EasyAdjust viene proposto per fori passanti e ciechi con due diverse tipologie di inserto:

Inserto a fissaggio meccanico HX

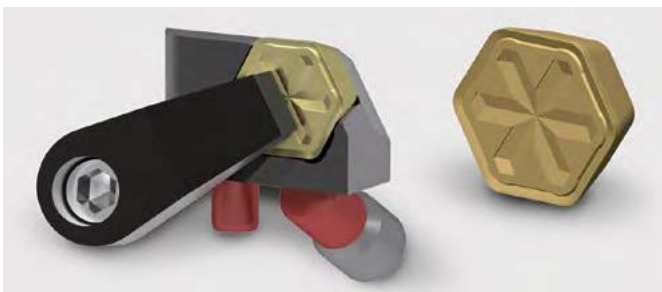

Inserto a fissaggio meccanico HX con sei taglienti per fori passanti.

Inserto a fissaggio meccanico TEC

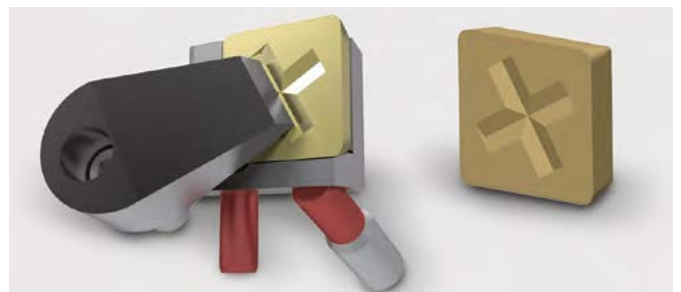

Inserto a fissaggio meccanico TEC con quattro taglienti e diverse geometrie di imbocco per foro cieco e spallamenti piani.



Foro passante

Adatto a fori aperti. Non adatto per spallamento se sono richiesti 90°.





Fori ciechi e fori in spalla piana

Adatto per fori chiusi e spallamenti piani, in considerazione della lunghezza del tagliente.

Riepilogo del programma





Sistema EasyAdjust con inserti a fissaggio meccanico HX

Criteri di scelta					Tipo di tagliente
Tipo di foro	Range di \varnothing Utensile	i	Graduazione della rastremazione*	Rastremazione	
Foro passante 	da \varnothing 20	B	Requisiti particolari	Rastremazione - ↓ +	HX 
		D	Standard consigliato		
		F	Requisiti particolari		
		H			
		K			
		M			
		P			
		R			
	da \varnothing 30	B	Requisiti particolari	Rastremazione - ↓ +	
		D	Standard consigliato		
		F	Requisiti particolari		
		H			
		K			
		M			
P					
R					

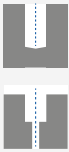

Sistema EasyAdjust con inserti a fissaggio meccanico TEC

Criteri di scelta					Tipo di tagliente
Tipo di foro	Range di \varnothing Utensile	i	Graduazione della rastremazione*	Rastremazione	
Foro cieco / Spalla piana 	da \varnothing 20	B	Requisiti particolari	Rastremazione - ↓ +	TEC 
		D	Standard consigliato		
		F	Requisiti particolari		
		H			
		K			
		M			
		P			
		R			
	da \varnothing 30	B	Requisiti particolari	Rastremazione - ↓ +	
		D	Standard consigliato		
		F	Requisiti particolari		
		H			
		K			
		M			
P					
R					

Misure in mm.

Per gli inserti a fissaggio meccanico idonei vedere pagina 518.

*Scelta a seconda dei requisiti dei componenti previo consulto con MAPAL.

Nota:

In caso di cambio di sistema, accertarsi che la cartuccia sia adatta alla staffa di serraggio.

Inseri a fissaggio meccanico HX per la lavorazione di fori

Per utensili con pattini di guida

Materiale da taglio	Metallo duro									
GTM*	P				M	K	N			
	1.1 - 1.2	2 - 3 5	4 6	1 - 3	1.1	2 - 3	1.1 - 1.2	2.3	2.1 - 2.2	
Tipo di materiale da taglio	HP342	HP122	HP018	HP018	HC419	HP122	HP612	HU612		

Geometria rompitruolo	Dimen- sione strutturale	Imboc- co	Specifiche	Codice								
negativo	2	R0,8	WP-K1288-2133-...									
	3	R0,8	WP-K1288-2123-...									

neutro	2	R0,8	WP-606087689-...					30688944				
	3	R0,8	WP-606087714-...					30688981				

positivo	2	R0,8	WP-HX228RL-...	30685704	30197811	31100892	31100892		30197811		30320977	
	3	R0,8	WP-HX238RL-...	30685705	30669024	31100893	31100893		30669024		30669021	

altamente positivo	2	R0,8	WP-HX128RL-...							30685707		30669011
	3	R0,8	WP-HX138RL-...							30685708		30669015



Metallo duro			Cermet		PCD		PcBN	
S		H	P		N		K	H
1 - 2		1.1	1 - 3 5		1 - 2		1.1	1.1 - 1.2
HU612		HP018	CP122		PU620		FU485	FU801
Codice			Codice		Codice		Codice	
							30009396**	30033403**
							30008170**	30097476**
		31100892	30222667		31290969**			
		31100893	30222666		31290980**			
30669011								
30669015								

Inseri a fissaggio meccanico TEC per la lavorazione di fori

Per utensili con pattini di guida

Materiale da taglio	Metallo duro								
GTM*	P			M	K		N		
	1.1 - 1.2	2 - 3 5	4 6	1 - 3	1.1	2 - 3	1.1 - 1.2	2.3	2.1 - 2.2
Tipo di materiale da taglio	HP115	HP425	HP016	HP016	HC418	HP426	HP612	HU615	

Geometria rompitrucolo	Dimensione strutturale	Imbocco	Specifiche	Codice							
negativo	2	AS	WP-TEC2-ASS35R0A-...								
		** EK	WP-TEC2-EKS35R0A-...								
		DZ	WP-TEC2-DZS35R0A-...								
		** R0,4	WP-TEC2-04S35R0A-...								

neutro	2	AS	WP-TEC2-ASE02R0A-...								
		** EK	WP-TEC2-EKE02R0A-...								
		DZ	WP-TEC2-DZE02R0A-...					31306739			
		** R0,4	WP-TEC2-04E02R0A-...					31306750			

positivo	2	AS	WP-TEC2-ASF01R1G-...	31099198	30953115	31099199	31099199				31306751
		** EK	WP-TEC2-EKF01R1G-...	31306755	31306756	31306758	31306758				31306761
		DZ	WP-TEC2-DZF01R1G-...	31306854	31100514	31100517	31100517		31306855		31306857
		** R0,4	WP-TEC2-04F01R1J-...	31306873	31306875	31306876	31306876		31306878		31306879

altamente positivo	2	AS	WP-TEC2-ASF01R1N-...							31306883	31306887
		** EK	WP-TEC2-EKF01R1N-...							31306903	31306904
		DZ	WP-TEC2-DZF01R1N-...							31306907	31306920
		** R0,4	WP-TEC2-04F01R1U-...							30685231	31306921

** Nota: Utilizzare l'imbocco EK e R0,4 solo per la lavorazione di fori ciechi e la sfacciatura in base ai requisiti dei componenti



Metallo duro		
S		H
1 - 2		1.1
HU615		HP016

Codice	

Codice	

Codice	
	31100517
	31306876

31306887	
31306904	
31306920	
31306921	

Cermet	
P	
1 - 3 5	
CP122	

Codice	

Codice	

31306753	
31306762	
31306870	
31306880	

PCD	
N	
1 - 2	
PU620	

Codice	

Codice	

31306754**	
31306763**	
31306871**	
30823892**	

PcBN	
K	H
1.1	1.1 - 1.2
FU485	FU801

Codice	
31306734**	31306735**
30539027**	30688967**

Codice	

Codice	

Accessori per sistema EasyAdjust



Dimensione tagliente TEC	Cartucce lame per sistema EasyAdjust		Inseriti di bloccaggio per sistema EasyAdjust	
	Specifiche	Codice	Specifiche	Codice
2	BC-EAS-R-42-B	30546828	CP-EAS-R-N2-B	30508276
2	BC-EAS-R-42-D	30498068	CP-EAS-R-N2-D	30561484
2	BC-EAS-R-42-F	30503101	CP-EAS-R-N2-F	30561485
2	BC-EAS-R-42-H	30503104	CP-EAS-R-N2-H	30561487
2	BC-EAS-R-42-K	30546837	CP-EAS-R-N2-K	30561488
2	BC-EAS-R-42-M	30546839	CP-EAS-R-N2-M	30561489
2	BC-EAS-R-42-P	30546840	CP-EAS-R-N2-P	30561490
2	BC-EAS-R-42-R	30546841	CP-EAS-R-N2-R	30508277
3	BC-EAS-R-43-B	30546844	CP-EAS-R-N3-B	30561492
3	BC-EAS-R-43-D	30498067	CP-EAS-R-N3-D	30561493
3	BC-EAS-R-43-F	30503115	CP-EAS-R-N3-F	30561494
3	BC-EAS-R-43-H	30503116	CP-EAS-R-N3-H	30561495
3	BC-EAS-R-43-K	30546845	CP-EAS-R-N3-K	30561496
3	BC-EAS-R-43-M	30546846	CP-EAS-R-N3-M	30561497
3	BC-EAS-R-43-P	30546848	CP-EAS-R-N3-P	30561498
3	BC-EAS-R-43-R	30546849	CP-EAS-R-N3-R	30561499



Dimensione tagliente HX	Cartucce lame per sistema EasyAdjust		Inseriti di bloccaggio per sistema EasyAdjust	
	Specifiche	Codice	Specifiche	Codice
2	BC-EAS-R-62-B	30275903	CP-EAS-R-N2-B	30508276
2	BC-EAS-R-62-D	30410077	CP-EAS-R-N2-D	30561484
2	BC-EAS-R-62-F	30503094	CP-EAS-R-N2-F	30561485
2	BC-EAS-R-62-H	30503096	CP-EAS-R-N2-H	30561487
2	BC-EAS-R-62-K	30496821	CP-EAS-R-N2-K	30561488
2	BC-EAS-R-62-M	30471831	CP-EAS-R-N2-M	30561489
2	BC-EAS-R-62-P	30471833	CP-EAS-R-N2-P	30561490
2	BC-EAS-R-62-R	30496828	CP-EAS-R-N2-R	30508277
3	BC-EAS-R-63-B	30495992	CP-EAS-R-N3-B	30561492
3	BC-EAS-R-63-D	30469856	CP-EAS-R-N3-D	30561493
3	BC-EAS-R-63-F	30503097	CP-EAS-R-N3-F	30561494
3	BC-EAS-R-63-H	30503098	CP-EAS-R-N3-H	30561495
3	BC-EAS-R-63-K	30496827	CP-EAS-R-N3-K	30561496
3	BC-EAS-R-63-M	30471832	CP-EAS-R-N3-M	30561497
3	BC-EAS-R-63-P	30471834	CP-EAS-R-N3-P	30561498
3	BC-EAS-R-63-R	30496829	CP-EAS-R-N3-R	30561499

Parametri di lavorazione consigliati per inserti a fissaggio meccanico HX

Avanzamento e velocità di taglio

HX-HP342

GTM*	Materiale	Resistenza/durezza [N/mm ²] [HRC]	Velocità di taglio v_c (m/min)		Avanzamento f_z (mm/z)	
			Adduzione interna del refrigerante	Raffreddamento esterno		
P P1	P1.1	Acciai da costruzione, automatici, da cementazione e da bonifica, non legati	< 700	80	40	0,150
	P1.2	Acciai da costruzione, automatici, da cementazione e da bonifica, non legati	< 1200	70	35	0,150

HX-HP122

GTM*	Materiale	Resistenza/durezza [N/mm ²] [HRC]	Velocità di taglio v_c (m/min)		Avanzamento f_z (mm/z)		
			Adduzione interna del refrigerante	Raffreddamento esterno			
P P2	P2.1	Acciai da nitrurazione, da cementazione e da bonifica, legati	< 900	100	50	0,150	
	P2.2	Acciai da nitrurazione, da cementazione e da bonifica, legati	< 1400	80	40	0,150	
	P3	P3.1	Acciai per utensili, per cuscinetti volventi, armonici e per lavorazioni veloci**	< 900	100	50	0,150
		P3.2	Acciai per utensili, per cuscinetti volventi, armonici e per lavorazioni veloci**	< 1500	80	40	0,150
	P5	P5.1	Acciaio fuso		80	40	0,150

HX-HP018

GTM*	Materiale	Resistenza/durezza [N/mm ²] [HRC]	Velocità di taglio v_c (m/min)		Avanzamento f_z (mm/z)		
			Adduzione interna del refrigerante	Raffreddamento esterno			
P4 P6	P4.1	Acciai inossidabili, ferritici e martensitici		50	25	0,120	
	P6.1	Acciaio fuso, ferritico e martensitico		40	20	0,120	
M	M1	M1.1	Acciai inossidabili, austenitici	< 700	50	25	0,120
		M1.2	Acciai inossidabili, ferritici/austenitici (Duplex)	< 1000	30	15	0,120
	M2	M2.1	Acciaio fuso inossidabile, austenitico	< 700	50	25	0,120
		M3	M3.1	Acciaio fuso inossidabile, ferritico/austenitico (Duplex)	< 1000	30	15

HX-HC419

GTM*	Materiale	Resistenza/durezza [N/mm ²] [HRC]	Velocità di taglio v_c (m/min)		Avanzamento f_z (mm/z)	
			Adduzione interna del refrigerante	Raffreddamento esterno		
K K1	K1.1	Ghisa con grafite lamellare (ghisa grigia), GJL	< 300	110	55	0,150

* Gruppi di materiale MAPAL

** Qualora la somma dei componenti di lega Cr, Mo, Ni, V, W equivalesse a > 8%, selezionare il gruppo di materiale MAPAL immediatamente superiore.

HX-HP122

GTM*	Materiale	Resistenza/durezza [N/mm ²] [HRC]	Velocità di taglio v _c (m/min)		Avanzamento f _z (mm/z)
			Adduzione interna del refrigerante	Raffredda- mento esterno	
K2	K2.1 Ghisa con grafite sferoidale, GJS	< 500	100	50	0,150
	K2.2 Ghisa con grafite sferoidale, GJS	≤ 800	90	45	0,150
	K2.3 Ghisa con grafite sferoidale, GJS	> 800	80	40	0,150
K3	K3.1 Ghisa con grafite vermicolare, GJV; acciaio fuso malleabile, GJM	< 500	70	35	0,150
	K3.2 Ghisa con grafite vermicolare, GJV; acciaio fuso malleabile, GJM	> 500	70	35	0,150

HX-HP612

GTM*	Materiale	Resistenza/durezza [N/mm ²] [HRC]	Velocità di taglio v _c (m/min)		Avanzamento f _z (mm/z)
			Adduzione interna del refrigerante	Raffredda- mento esterno	
N N1	N1.1 Alluminio, non legato e legato < 3% Si		160	80	0,150
	N1.2 Alluminio, legato ≤ 7% Si		160	80	0,150

HX-HU612

GTM*	Materiale	Resistenza/durezza [N/mm ²] [HRC]	Velocità di taglio v _c (m/min)		Avanzamento f _z (mm/z)
			Adduzione interna del refrigerante	Raffredda- mento esterno	
N N2	N2.1 Rame, non legato e bassolegato	< 300	100	50	0,150
	N2.2 Rame, legato	> 300	100	50	0,150
	N2.3 Ottone, bronzo, ghisa rossa	< 1200	100	50	0,150
S S1 S2	S1.1 Titanio, leghe di titanio	< 400	30	15	0,120
	S2.1 Titanio, leghe di titanio	< 1200	20	10	0,120
	S2.2 Titanio, leghe di titanio	> 1200	20	10	0,100

HX-HP018

GTM*	Materiale	Resistenza/durezza [N/mm ²] [HRC]	Velocità di taglio v _c (m/min)		Avanzamento f _z (mm/z)
			Adduzione interna del refrigerante	Raffredda- mento esterno	
H H1 H1.1	Acciaio temprato/acciaio fuso	45 - 55	30	15	0,120

I parametri di lavorazione indicati sono valori orientativi.

I dati ottimali per la specifica applicazione devono essere rilevati eseguendo diversi tentativi o durante l'effettiva lavorazione.

Parametri di lavorazione consigliati per inserti a fissaggio meccanico HX

Avanzamento e velocità di taglio

HX-CP122

GTM*	Materiale	Resistenza/durezza [N/mm ²] [HRC]	Velocità di taglio v _c (m/min)		Avanzamento f _z (mm/z)	
			Adduzione interna del refrigerante	Raffredda- mento esterno		
P	P1.1	Acciai da costruzione, automatici, da cementazione e da bonifica, non legati	< 700	180	90	0,150
	P1.2	Acciai da costruzione, automatici, da cementazione e da bonifica, non legati	< 1200	160	80	0,120
	P2.1	Acciai da nitrurazione, da cementazione e da bonifica, legati	< 900	160	80	0,150
	P2.2	Acciai da nitrurazione, da cementazione e da bonifica, legati	< 1400	140	70	0,120
	P3.1	Acciai per utensili, per cuscinetti volventi, armonici e per lavorazioni veloci**	< 800	160	80	0,150
	P3.2	Acciai per utensili, per cuscinetti volventi, armonici e per lavorazioni veloci**	< 1000	160	80	0,150
	P3.3	Acciai per utensili, per cuscinetti volventi, armonici e per lavorazioni veloci**	< 1500	140	70	0,120
	P5.1	Acciaio fuso		140	70	0,120

HX-PU620

GTM*	Materiale	Resistenza/durezza [N/mm ²] [HRC]	Velocità di taglio v _c (m/min)		Avanzamento f _z (mm/z)	
			Adduzione interna del refrigerante	Raffredda- mento esterno		
N	N1.1	Alluminio, non legato e legato < 3% Si		230	115	0,150
	N1.2	Alluminio, legato ≤ 7% Si		230	115	0,150
	N1.3	Alluminio, legato > 7-12% Si		230	115	0,150
	N1.4	Alluminio, legato > 12% Si		230	115	0,150
	N2.1	Rame, non legato e bassolegato	< 300	180	90	0,150
	N2.2	Rame, legato	> 300	180	90	0,150
	N2.3	Ottone, bronzo, ghisa rossa	< 1200	180	90	0,150

HX-FU485

GTM*	Materiale	Resistenza/durezza [N/mm ²] [HRC]	Velocità di taglio v _c (m/min)		Avanzamento f _z (mm/z)	
			Adduzione interna del refrigerante	Raffredda- mento esterno		
K K1	K1.1	Ghisa con grafite lamellare (ghisa grigia), GJL	< 300	150	75	0,150

HX-FU801

GTM*	Materiale	Resistenza/durezza [N/mm ²] [HRC]	Velocità di taglio v _c (m/min)		Avanzamento f _z (mm/z)	
			Adduzione interna del refrigerante	Raffredda- mento esterno		
H H1	H1.1	Acciaio temprato/acciaio fuso	45 - 55	60	30	0,100
	H1.2	Acciaio temprato/acciaio fuso	55 - 64	50	25	0,080

* Gruppi di materiale MAPAL

** Qualora la somma dei componenti di lega Cr, Mo, Ni, V, W equivalesse a > 8%, selezionare il gruppo di materiale MAPAL immediatamente superiore.

Parametri di lavorazione consigliati per inserti a fissaggio meccanico TEC

Avanzamento e velocità di taglio

TEC2-AS-HP115

GTM*	Materiale	Resistenza/durezza [N/mm ²] [HRC]	Velocità di taglio v_c (m/min)		Avanzamento f_z (mm/z)	
			Adduzione interna del refrigerante	Raffredda- mento esterno		
P P1	P1.1	Acciai da costruzione, automatici, da cementazione e da bonifica, non legati	< 700	80	40	0,150
	P1.2	Acciai da costruzione, automatici, da cementazione e da bonifica, non legati	< 1200	70	35	0,150

TEC2-EK-HP115

GTM*	Materiale	Resistenza/durezza [N/mm ²] [HRC]	Velocità di taglio v_c (m/min)		Avanzamento f_z (mm/z)	
			Adduzione interna del refrigerante	Raffredda- mento esterno		
P P1	P1.1	Acciai da costruzione, automatici, da cementazione e da bonifica, non legati	< 700 N/mm ²	80	40	0,150
	P1.2	Acciai da costruzione, automatici, da cementazione e da bonifica, non legati	< 1200 N/mm ²	70	35	0,150

TEC2-DZ-HP115

GTM*	Materiale	Resistenza/durezza [N/mm ²] [HRC]	Velocità di taglio v_c (m/min)		Avanzamento f_z (mm/z)	
			Adduzione interna del refrigerante	Raffredda- mento esterno		
P P1	P1.1	Acciai da costruzione, automatici, da cementazione e da bonifica, non legati	< 700	80	40	0,150
	P1.2	Acciai da costruzione, automatici, da cementazione e da bonifica, non legati	< 1200	70	35	0,150

TEC2-04-HP115

GTM*	Materiale	Resistenza/durezza [N/mm ²] [HRC]	Velocità di taglio v_c (m/min)		Avanzamento f_z (mm/z)	
			Adduzione interna del refrigerante	Raffredda- mento esterno		
P P1	P1.1	Acciai da costruzione, automatici, da cementazione e da bonifica, non legati	< 700	80	40	0,150
	P1.2	Acciai da costruzione, automatici, da cementazione e da bonifica, non legati	< 1200	70	35	0,150

TEC2-AS-HP425

GTM*	Materiale	Resistenza/durezza [N/mm ²] [HRC]	Velocità di taglio v_c (m/min)		Avanzamento f_z (mm/z)	
			Adduzione interna del refrigerante	Raffredda- mento esterno		
P P2 P3 P5	P2.1	Acciai da niturazione, da cementazione e da bonifica, legati	< 900	100	50	0,150
	P2.2	Acciai da niturazione, da cementazione e da bonifica, legati	< 1400	80	40	0,150
	P3.1	Acciai per utensili, per cuscinetti volventi, armonici e per lavorazioni veloci**	< 900	100	50	0,150
	P3.2	Acciai per utensili, per cuscinetti volventi, armonici e per lavorazioni veloci**	< 1500	80	40	0,150
	P5.1	Acciaio fuso		80	40	0,150

I parametri di lavorazione indicati sono valori orientativi.

I dati ottimali per la specifica applicazione devono essere rilevati eseguendo diversi tentativi o durante l'effettiva lavorazione.

Parametri di lavorazione consigliati per inserti a fissaggio meccanico TEC

Avanzamento e velocità di taglio

TEC2-EK-HP425

GTM*	Materiale	Resistenza/durezza [N/mm ²] [HRC]	Velocità di taglio v_c (m/min)		Avanzamento f_z (mm/z)	
			Adduzione interna del refrigerante	Raffredda- mento esterno		
P	P2.1	Acciai da nitrurazione, da cementazione e da bonifica, legati	< 900	100	50	0,150
	P2.2	Acciai da nitrurazione, da cementazione e da bonifica, legati	< 1400	80	40	0,150
	P3.1	Acciai per utensili, per cuscinetti volventi, armonici e per lavorazioni veloci**	< 900	100	50	0,150
	P3.2	Acciai per utensili, per cuscinetti volventi, armonici e per lavorazioni veloci**	< 1500	80	40	0,150
	P5.1	Acciaio fuso		80	40	0,150

TEC2-DZ-HP425

GTM*	Materiale	Resistenza/durezza [N/mm ²] [HRC]	Velocità di taglio v_c (m/min)		Avanzamento f_z (mm/z)	
			Adduzione interna del refrigerante	Raffredda- mento esterno		
P	P2.1	Acciai da nitrurazione, da cementazione e da bonifica, legati	< 900	100	50	0,150
	P2.2	Acciai da nitrurazione, da cementazione e da bonifica, legati	< 1400	80	40	0,150
	P3.1	Acciai per utensili, per cuscinetti volventi, armonici e per lavorazioni veloci**	< 900	100	50	0,150
	P3.2	Acciai per utensili, per cuscinetti volventi, armonici e per lavorazioni veloci**	< 1500	80	40	0,150
	P5.1	Acciaio fuso		80	40	0,150

TEC2-04-HP425

GTM*	Materiale	Resistenza/durezza [N/mm ²] [HRC]	Velocità di taglio v_c (m/min)		Avanzamento f_z (mm/z)	
			Adduzione interna del refrigerante	Raffredda- mento esterno		
P	P2.1	Acciai da nitrurazione, da cementazione e da bonifica, legati	< 900	100	50	0,150
	P2.2	Acciai da nitrurazione, da cementazione e da bonifica, legati	< 1400	80	40	0,150
	P3.1	Acciai per utensili, per cuscinetti volventi, armonici e per lavorazioni veloci**	< 900	100	50	0,150
	P3.2	Acciai per utensili, per cuscinetti volventi, armonici e per lavorazioni veloci**	< 1500	80	40	0,150
	P5.1	Acciaio fuso		80	40	0,150

TEC2-AS-HP016

GTM*	Materiale	Resistenza/durezza [N/mm ²] [HRC]	Velocità di taglio v_c (m/min)		Avanzamento f_z (mm/z)	
			Adduzione interna del refrigerante	Raffredda- mento esterno		
P4	P4.1	Acciai inossidabili, ferritici e martensitici		50	25	0,120
	P6.1	Acciaio fuso, ferritico e martensitico		40	20	0,120
M	M1.1	Acciai inossidabili, austenitici	< 700	50	25	0,120
	M1.2	Acciai inossidabili, ferritici/austenitici (Duplex)	< 1000	30	15	0,120
	M2.1	Acciaio fuso inossidabile, austenitico	< 700	50	25	0,120
M3	M3.1	Acciaio fuso inossidabile, ferritico/austenitico (Duplex)	< 1000	30	15	0,120

* Gruppi di materiale MAPAL

** Qualora la somma dei componenti di lega Cr, Mo, Ni, V, W equivalesse a > 8%, selezionare il gruppo di materiale MAPAL immediatamente superiore.

TEC2-EK-HP016

GTM*		Materiale	Resistenza/durezza [N/mm ²] [HRC]	Velocità di taglio v _c (m/min)		Avanzamento f _z (mm/z)	
				Adduzione interna del refrigerante	Raffredda- mento esterno		
P4	P4.1	Acciai inossidabili, ferritici e martensitici		50	25	0,120	
	P6	P6.1	Acciaio fuso, ferritico e martensitico	40	20	0,120	
M	M1	M1.1	Acciai inossidabili, austenitici	< 700	50	25	0,120
		M1.2	Acciai inossidabili, ferritici/austenitici (Duplex)	< 1000	30	15	0,120
	M2	M2.1	Acciaio fuso inossidabile, austenitico	< 700	50	25	0,120
	M3	M3.1	Acciaio fuso inossidabile, ferritico/austenitico (Duplex)	< 1000	30	15	0,120

TEC2-DZ-HP016

GTM*		Materiale	Resistenza/durezza [N/mm ²] [HRC]	Velocità di taglio v _c (m/min)		Avanzamento f _z (mm/z)	
				Adduzione interna del refrigerante	Raffredda- mento esterno		
P4	P4.1	Acciai inossidabili, ferritici e martensitici		50	25	0,120	
	P6	P6.1	Acciaio fuso, ferritico e martensitico	40	20	0,120	
M	M1	M1.1	Acciai inossidabili, austenitici	< 700	50	25	0,120
		M1.2	Acciai inossidabili, ferritici/austenitici (Duplex)	< 1000	30	15	0,120
	M2	M2.1	Acciaio fuso inossidabile, austenitico	< 700	50	25	0,120
	M3	M3.1	Acciaio fuso inossidabile, ferritico/austenitico (Duplex)	< 1000	30	15	0,120

TEC2-04-HP016

GTM*		Materiale	Resistenza/durezza [N/mm ²] [HRC]	Velocità di taglio v _c (m/min)		Avanzamento f _z (mm/z)	
				Adduzione interna del refrigerante	Raffredda- mento esterno		
P4	P4.1	Acciai inossidabili, ferritici e martensitici		50	25	0,120	
	P6	P6.1	Acciaio fuso, ferritico e martensitico	40	20	0,120	
M	M1	M1.1	Acciai inossidabili, austenitici	< 700	50	25	0,120
		M1.2	Acciai inossidabili, ferritici/austenitici (Duplex)	< 1000	30	15	0,120
	M2	M2.1	Acciaio fuso inossidabile, austenitico	< 700	50	25	0,120
	M3	M3.1	Acciaio fuso inossidabile, ferritico/austenitico (Duplex)	< 1000	30	15	0,120

TEC2-DZ-HC418

GTM*		Materiale	Resistenza/durezza [N/mm ²] [HRC]	Velocità di taglio v _c (m/min)		Avanzamento f _z (mm/z)	
				Adduzione interna del refrigerante	Raffredda- mento esterno		
K	K1	K1.1	Ghisa con grafite lamellare (ghisa grigia), GJL	< 300	100	50	0,150

I parametri di lavorazione indicati sono valori orientativi.

I dati ottimali per la specifica applicazione devono essere rilevati eseguendo diversi tentativi o durante l'effettiva lavorazione.

Parametri di lavorazione consigliati per inserti a fissaggio meccanico TEC

Avanzamento e velocità di taglio

TEC2-04-HC418

GTM*	Materiale	Resistenza/durezza [N/mm ²] [HRC]	Velocità di taglio v_c (m/min)		Avanzamento f_z (mm/z)
			Adduzione interna del refrigerante	Raffredda- mento esterno	
K K1 K1.1	Ghisa con grafite lamellare (ghisa grigia), GJL	< 300	100	50	0,150

TEC2-DZ-HP426

GTM*	Materiale	Resistenza/durezza [N/mm ²] [HRC]	Velocità di taglio v_c (m/min)		Avanzamento f_z (mm/z)
			Adduzione interna del refrigerante	Raffredda- mento esterno	
K2	K2.1 Ghisa con grafite sferoidale, GJS	< 500	100	50	0,150
	K2.2 Ghisa con grafite sferoidale, GJS	≤ 800	90	45	0,150
	K2.3 Ghisa con grafite sferoidale, GJS	> 800	80	40	0,150
K3	K3.1 Ghisa con grafite vermicolare, GJV; acciaio fuso malleabile, GJM	< 500	70	35	0,150
	K3.2 Ghisa con grafite vermicolare, GJV; acciaio fuso malleabile, GJM	> 500	70	35	0,150

TEC2-04-HP426

GTM*	Materiale	Resistenza/durezza [N/mm ²] [HRC]	Velocità di taglio v_c (m/min)		Avanzamento f_z (mm/z)
			Adduzione interna del refrigerante	Raffredda- mento esterno	
K2	K2.1 Ghisa con grafite sferoidale, GJS	< 500	100	50	0,150
	K2.2 Ghisa con grafite sferoidale, GJS	≤ 800	90	45	0,150
	K2.3 Ghisa con grafite sferoidale, GJS	> 800	80	40	0,150
K3	K3.1 Ghisa con grafite vermicolare, GJV; acciaio fuso malleabile, GJM	< 500	70	35	0,150
	K3.2 Ghisa con grafite vermicolare, GJV; acciaio fuso malleabile, GJM	> 500	70	35	0,150

TEC2-AS-HP612

GTM*	Materiale	Resistenza/durezza [N/mm ²] [HRC]	Velocità di taglio v_c (m/min)		Avanzamento f_z (mm/z)
			Adduzione interna del refrigerante	Raffredda- mento esterno	
N N1	N1.1 Alluminio, non legato e legato < 3% Si		160	80	0,150
	N1.2 Alluminio, legato ≤ 7% Si		160	80	0,150

TEC2-EK-HP612

GTM*	Materiale	Resistenza/durezza [N/mm ²] [HRC]	Velocità di taglio v_c (m/min)		Avanzamento f_z (mm/z)
			Adduzione interna del refrigerante	Raffredda- mento esterno	
N N1	N1.1 Alluminio, non legato e legato < 3% Si		160	80	0,150
	N1.2 Alluminio, legato ≤ 7% Si		160	80	0,150

* Gruppi di materiale MAPAL

TEC2-DZ-HP612

GTM*		Materiale	Resistenza/durezza [N/mm ²] [HRC]	Velocità di taglio v _c (m/min)		Avanzamento f _z (mm/z)
				Adduzione interna del refrigerante	Raffredda- mento esterno	
N	N1	N1.1 Alluminio, non legato e legato < 3% Si		160	80	0,150
	N1	N1.2 Alluminio, legato ≤ 7% Si		160	80	0,150

TEC2-04-HP612

GTM*		Materiale	Resistenza/durezza [N/mm ²] [HRC]	Velocità di taglio v _c (m/min)		Avanzamento f _z (mm/z)
				Adduzione interna del refrigerante	Raffredda- mento esterno	
N	N1	N1.1 Alluminio, non legato e legato < 3% Si		160	80	0,150
	N1	N1.2 Alluminio, legato ≤ 7% Si		160	80	0,150

TEC2-AS-HU615

GTM*		Materiale	Resistenza/durezza [N/mm ²] [HRC]	Velocità di taglio v _c (m/min)		Avanzamento f _z (mm/z)
				Adduzione interna del refrigerante	Raffredda- mento esterno	
N	N2	N2.1 Rame, non legato e bassolegato	< 300	100	50	0,150
		N2.2 Rame, legato	> 300	100	50	0,150
		N2.3 Ottone, bronzo, ghisa rossa	< 1200	100	50	0,150
S	S1	S1.1 Titanio, leghe di titanio	< 400	30	15	0,120
		S2.1 Titanio, leghe di titanio	< 1200	20	10	0,120
		S2.2 Titanio, leghe di titanio	> 1200	20	10	0,100

TEC2-EK-HU615

GTM*		Materiale	Resistenza/durezza [N/mm ²] [HRC]	Velocità di taglio v _c (m/min)		Avanzamento f _z (mm/z)
				Adduzione interna del refrigerante	Raffredda- mento esterno	
N	N2	N2.1 Rame, non legato e bassolegato	< 300	100	50	0,150
		N2.2 Rame, legato	> 300	100	50	0,150
		N2.3 Ottone, bronzo, ghisa rossa	< 1200	100	50	0,150
S	S1	S1.1 Titanio, leghe di titanio	< 400	30	15	0,120
		S2.1 Titanio, leghe di titanio	< 1200	20	10	0,120
		S2.2 Titanio, leghe di titanio	> 1200	20	10	0,100

I parametri di lavorazione indicati sono valori orientativi.

I dati ottimali per la specifica applicazione devono essere rilevati eseguendo diversi tentativi o durante l'effettiva lavorazione.

Parametri di lavorazione consigliati per inserti a fissaggio meccanico TEC

Avanzamento e velocità di taglio

TEC2-DZ-HU615

GTM*			Materiale	Resistenza/durezza [N/mm ²] [HRC]	Velocità di taglio v_c (m/min)		Avanzamento f_z (mm/z)
					Adduzione interna del refrigerante	Raffredda- mento esterno	
N	N2	N2.1	Rame, non legato e bassolegato	< 300	100	50	0,150
		N2.2	Rame, legato	> 300	100	50	0,150
		N2.3	Ottone, bronzo, ghisa rossa	< 1200	100	50	0,150
S	S2	S2.1	Titanio, leghe di titanio	< 400	30	15	0,120
		S2.1	Titanio, leghe di titanio	< 1200	20	10	0,120
		S2.2	Titanio, leghe di titanio	> 1200	20	10	0,100

TEC2-04-HU615

GTM*			Materiale	Resistenza/durezza [N/mm ²] [HRC]	Velocità di taglio v_c (m/min)		Avanzamento f_z (mm/z)
					Adduzione interna del refrigerante	Raffredda- mento esterno	
N	N2	N2.1	Rame, non legato e bassolegato	< 300	100	50	0,150
		N2.2	Rame, legato	> 300	100	50	0,150
		N2.3	Ottone, bronzo, ghisa rossa	< 1200	100	50	0,150
S	S2	S2.1	Titanio, leghe di titanio	< 400	30	15	0,120
		S2.1	Titanio, leghe di titanio	< 1200	20	10	0,120
		S2.2	Titanio, leghe di titanio	> 1200	20	10	0,100

TEC2-DZ-HP016

GTM*			Materiale	Resistenza/durezza [N/mm ²] [HRC]	Velocità di taglio v_c (m/min)		Avanzamento f_z (mm/z)
					Adduzione interna del refrigerante	Raffredda- mento esterno	
H	H1	H1.1	Acciaio temprato/acciaio fuso	45 - 55	30	15	0,120

TEC2-04-HP016

GTM*			Materiale	Resistenza/durezza [N/mm ²] [HRC]	Velocità di taglio v_c (m/min)		Avanzamento f_z (mm/z)
					Adduzione interna del refrigerante	Raffredda- mento esterno	
H	H1	H1.1	Acciaio temprato/acciaio fuso	45 - 55	30	15	0,120

* Gruppi di materiale MAPAL

** Qualora la somma dei componenti di lega Cr, Mo, Ni, V, W equivalesse a > 8%, selezionare il gruppo di materiale MAPAL immediatamente superiore.

TEC2-AS-CP122

GTM*	Materiale	Resistenza/durezza [N/mm ²] [HRC]	Velocità di taglio v _c (m/min)		Avanzamento f _z (mm/z)	
			Adduzione interna del refrigerante	Raffredda- mento esterno		
P	P1	P1.1 Acciai da costruzione, automatici, da cementazione e da bonifica, non legati	< 700	180	90	0,150
		P1.2 Acciai da costruzione, automatici, da cementazione e da bonifica, non legati	< 1200	160	80	0,120
	P2	P2.1 Acciai da nitrurazione, da cementazione e da bonifica, legati	< 900	160	80	0,150
		P2.2 Acciai da nitrurazione, da cementazione e da bonifica, legati	< 1400	140	70	0,120
	P3	P3.1 Acciai per utensili, per cuscinetti volventi, armonici e per lavorazioni veloci**	< 800	160	80	0,150
		P3.2 Acciai per utensili, per cuscinetti volventi, armonici e per lavorazioni veloci**	< 1000	160	80	0,150
		P3.3 Acciai per utensili, per cuscinetti volventi, armonici e per lavorazioni veloci**	< 1500	140	70	0,120
	P5	P5.1 Acciaio fuso		140	70	0,120

TEC2-EK-CP122

GTM*	Materiale	Resistenza/durezza [N/mm ²] [HRC]	Velocità di taglio v _c (m/min)		Avanzamento f _z (mm/z)	
			Adduzione interna del refrigerante	Raffredda- mento esterno		
P	P1	P1.1 Acciai da costruzione, automatici, da cementazione e da bonifica, non legati	< 700	180	90	0,150
		P1.2 Acciai da costruzione, automatici, da cementazione e da bonifica, non legati	< 1200	160	80	0,120
	P2	P2.1 Acciai da nitrurazione, da cementazione e da bonifica, legati	< 900	160	80	0,150
		P2.2 Acciai da nitrurazione, da cementazione e da bonifica, legati	< 1400	140	70	0,120
	P3	P3.1 Acciai per utensili, per cuscinetti volventi, armonici e per lavorazioni veloci**	< 800	160	80	0,150
		P3.2 Acciai per utensili, per cuscinetti volventi, armonici e per lavorazioni veloci**	< 1000	160	80	0,150
		P3.3 Acciai per utensili, per cuscinetti volventi, armonici e per lavorazioni veloci**	< 1500	140	70	0,120
	P5	P5.1 Acciaio fuso		140	70	0,120

TEC2-DZ-CP122

GTM*	Materiale	Resistenza/durezza [N/mm ²] [HRC]	Velocità di taglio v _c (m/min)		Avanzamento f _z (mm/z)	
			Adduzione interna del refrigerante	Raffredda- mento esterno		
P	P1	P1.1 Acciai da costruzione, automatici, da cementazione e da bonifica, non legati	< 700	180	90	0,150
		P1.2 Acciai da costruzione, automatici, da cementazione e da bonifica, non legati	< 1200	160	80	0,120
	P2	P2.1 Acciai da nitrurazione, da cementazione e da bonifica, legati	< 900	160	80	0,150
		P2.2 Acciai da nitrurazione, da cementazione e da bonifica, legati	< 1400	140	70	0,120
	P3	P3.1 Acciai per utensili, per cuscinetti volventi, armonici e per lavorazioni veloci**	< 800	160	80	0,150
		P3.2 Acciai per utensili, per cuscinetti volventi, armonici e per lavorazioni veloci**	< 1000	160	80	0,150
		P3.3 Acciai per utensili, per cuscinetti volventi, armonici e per lavorazioni veloci**	< 1500	140	70	0,120
	P5	P5.1 Acciaio fuso		140	70	0,120

I parametri di lavorazione indicati sono valori orientativi.

I dati ottimali per la specifica applicazione devono essere rilevati eseguendo diversi tentativi o durante l'effettiva lavorazione.

Parametri di lavorazione consigliati per inserti a fissaggio meccanico TEC

Avanzamento e velocità di taglio

TEC2-04-CP122

GTM*	Materiale	Resistenza/durezza [N/mm ²] [HRC]	Velocità di taglio v _c (m/min)		Avanzamento f _z (mm/z)	
			Adduzione interna del refrigerante	Raffredda- mento esterno		
P1	P1.1	Acciai da costruzione, automatici, da cementazione e da bonifica, non legati	< 700	180	90	0,150
	P1.2	Acciai da costruzione, automatici, da cementazione e da bonifica, non legati	< 1200	160	80	0,120
P2	P2.1	Acciai da nitrurazione, da cementazione e da bonifica, legati	< 900	160	80	0,150
	P2.2	Acciai da nitrurazione, da cementazione e da bonifica, legati	< 1400	140	70	0,120
P3	P3.1	Acciai per utensili, per cuscinetti volventi, armonici e per lavorazioni veloci**	< 800	160	80	0,150
	P3.2	Acciai per utensili, per cuscinetti volventi, armonici e per lavorazioni veloci**	< 1000	160	80	0,150
	P3.3	Acciai per utensili, per cuscinetti volventi, armonici e per lavorazioni veloci**	< 1500	140	70	0,120
P5	P5.1	Acciaio fuso		140	70	0,120

TEC2-AS-PU620

GTM*	Materiale	Resistenza/durezza [N/mm ²] [HRC]	Velocità di taglio v _c (m/min)		Avanzamento f _z (mm/z)	
			Adduzione interna del refrigerante	Raffredda- mento esterno		
N1	N1.1	Alluminio, non legato e legato < 3% Si		230	115	0,150
	N1.2	Alluminio, legato ≤ 7% Si		230	115	0,150
	N1.3	Alluminio, legato > 7-12% Si		230	115	0,150
	N1.4	Alluminio, legato > 12% Si		230	115	0,150
N2	N2.1	Rame, non legato e bassolegato	< 300	180	90	0,150
	N2.2	Rame, legato	> 300	180	90	0,150
	N2.3	Ottone, bronzo, ghisa rossa	< 1200	180	90	0,150

TEC2-EK-PU620

GTM*	Materiale	Resistenza/durezza [N/mm ²] [HRC]	Velocità di taglio v _c (m/min)		Avanzamento f _z (mm/z)	
			Adduzione interna del refrigerante	Raffredda- mento esterno		
N1	N1.1	Alluminio, non legato e legato < 3% Si		230	115	0,150
	N1.2	Alluminio, legato ≤ 7% Si		230	115	0,150
	N1.3	Alluminio, legato > 7-12% Si		230	115	0,150
	N1.4	Alluminio, legato > 12% Si		230	115	0,150
N2	N2.1	Rame, non legato e bassolegato	< 300	180	90	0,150
	N2.2	Rame, legato	> 300	180	90	0,150
	N2.3	Ottone, bronzo, ghisa rossa	< 1200	180	90	0,150

* Gruppi di materiale MAPAL

** Qualora la somma dei componenti di lega Cr, Mo, Ni, V, W equivalesse a > 8%, selezionare il gruppo di materiale MAPAL immediatamente superiore.

TEC2-DZ-PU620

GTM*	Materiale	Resistenza/durezza [N/mm ²] [HRC]	Velocità di taglio v _c (m/min)		Avanzamento f _z (mm/z)	
			Adduzione interna del refrigerante	Raffredda- mento esterno		
N	N1	N1.1 Alluminio, non legato e legato < 3% Si		230	115	0,150
		N1.2 Alluminio, legato ≤ 7% Si		230	115	0,150
		N1.3 Alluminio, legato > 7-12% Si		230	115	0,150
		N1.4 Alluminio, legato > 12% Si		230	115	0,150
	N2	N2.1 Rame, non legato e bassolegato	< 300	180	90	0,150
		N2.2 Rame, legato	> 300	180	90	0,150
		N2.3 Ottone, bronzo, ghisa rossa	< 1200	180	90	0,150

TEC2-04-PU620

GTM*	Materiale	Resistenza/durezza [N/mm ²] [HRC]	Velocità di taglio v _c (m/min)		Avanzamento f _z (mm/z)	
			Adduzione interna del refrigerante	Raffredda- mento esterno		
N	N1	N1.1 Alluminio, non legato e legato < 3% Si		230	115	0,150
		N1.2 Alluminio, legato ≤ 7% Si		230	115	0,150
		N1.3 Alluminio, legato > 7-12% Si		230	115	0,150
		N1.4 Alluminio, legato > 12% Si		230	115	0,150
	N2	N2.1 Rame, non legato e bassolegato	< 300	180	90	0,150
		N2.2 Rame, legato	> 300	180	90	0,150
		N2.3 Ottone, bronzo, ghisa rossa	< 1200	180	90	0,150

I parametri di lavorazione indicati sono valori orientativi.

I dati ottimali per la specifica applicazione devono essere rilevati eseguendo diversi tentativi o durante l'effettiva lavorazione.

Parametri di lavorazione consigliati per inserti a fissaggio meccanico TEC

Avanzamento e velocità di taglio

TEC2-DZ-FU485

GTM*	Materiale	Resistenza/durezza [N/mm ²] [HRC]	Velocità di taglio v_c (m/min)		Avanzamento f_z (mm/z)
			Adduzione interna del refrigerante	Raffredda- mento esterno	
K K1 K1.1	Ghisa con grafite lamellare (ghisa grigia), GJL	< 300	150	75	0,150

TEC2-04-FU485

GTM*	Materiale	Resistenza/durezza [N/mm ²] [HRC]	Velocità di taglio v_c (m/min)		Avanzamento f_z (mm/z)
			Adduzione interna del refrigerante	Raffredda- mento esterno	
K K1 K1.1	Ghisa con grafite lamellare (ghisa grigia), GJL	< 300	150	75	0,150

TEC2-DZ-FU801

GTM*		Materiale	Resistenza/durezza [N/mm ²] [HRC]	Velocità di taglio v _c (m/min)		Avanzamento f _z (mm/z)	
				Adduzione interna del refrigerante	Raffredda- mento esterno		
H	H1	H1.1	Acciaio temprato/acciaio fuso	45 - 55	60	30	0,100
		H1.2	Acciaio temprato/acciaio fuso	55 - 64	50	25	0,080

TEC2-04-FU801

GTM*		Materiale	Resistenza/durezza [N/mm ²] [HRC]	Velocità di taglio v _c (m/min)		Avanzamento f _z (mm/z)	
				Adduzione interna del refrigerante	Raffredda- mento esterno		
H	H1	H1.1	Acciaio temprato/acciaio fuso	45 - 55	60	30	0,100
		H1.2	Acciaio temprato/acciaio fuso	55 - 64	50	25	0,080

I parametri di lavorazione indicati sono valori orientativi.

I dati ottimali per la specifica applicazione devono essere rilevati eseguendo diversi tentativi o durante l'effettiva lavorazione.



Facile utilizzo nell'alesatura esterna di piccoli diametri

Per consentire di gestire nel modo più semplice possibile il presettaggio degli alesatori esterni per la lavorazione di piccoli diametri, MAPAL ha sviluppato un nuovo sistema. Il sistema EasyA-djust è stato integrato in un'apposita cartuccia. Questa può essere smontata al fine di regolare il tagliente in modo semplice e rapido, mediante un micrometro o una misura dal piano.

Nel sistema EA la rastremazione del tagliente è già integrata nella sede del tagliente stesso. In questo modo viene completamente a decadere la procedura di regolazione della rastremazione del tagliente secondario. Sarà necessario regolare unicamente la sporgenza del tagliente rispetto ai pattini di guida. Grazie all'elevata precisione di cambio, nonché al semplicissimo presettaggio del tagliente, il nuovo sistema consente di rispettare in modo decisamente più facile le tolleranze richieste (fattore indispensabile per la sicurezza dei processi) in caso di accoppiamenti ad alta precisione anche con piccoli range di diametro.

IN SINTESI

- Nuovo sistema per un semplice presettaggio nell'alesatura esterna di piccoli diametri
- La cartuccia del sistema EA è integrata in un'ulteriore cartuccia smontabile
- Elevata precisione di cambio (inferiore a 2-3 μm)
- Il tagliente può essere regolato in modo semplice e rapido
- La rastremazione del tagliente è integrata nella cartuccia che funge da sede per il tagliente stesso

VANTAGGI

- Elevata redditività e alta sicurezza dei processi
- Ridotti oneri di regolazione grazie all'innovativa cartuccia nella cartuccia
- Semplice utilizzo
- La procedura di regolazione della rastremazione del tagliente secondario viene completamente a decadere
- Rispetto di severe tolleranze per la massima sicurezza dei processi



Alesatore esterno con sistema EasyAdjust | Distinzione sistema



Sistema EasyAdjust con inserto a fissaggio meccanico TEC

- Lavorazione multitagliente (numero di taglienti)
- Facile utilizzo
- Possibilità di taglienti TEC2 e TEC3

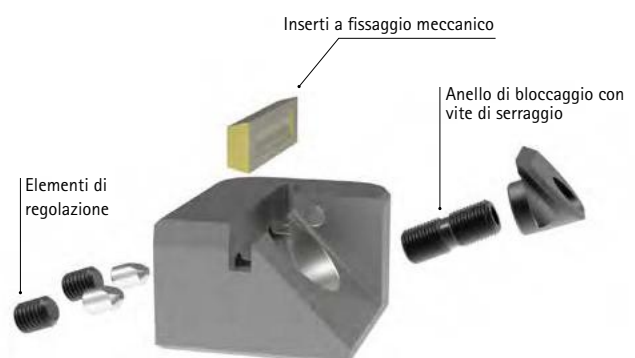

Inserti a fissaggio meccanico

- Elevati requisiti superficiali ad es. $< R_z 6$
- Profilo speciale (inserti a fissaggio meccanico)
- Sfacciatura
- Intestatura con trasferimento del raggio

Inseri a fissaggio meccanico TEC per utensili per la lavorazione esterna

Materiale da taglio	Metallo duro									
GTM*	P			M	K	N				
	1.1 - 1.2	2 - 3 5	4 6	1 - 3	1.1	2 - 3	1.1 - 1.2	2.3	2.1 - 2.2	
Tipo di materiale da taglio	HP115	HP425	HP016	HP016	HC418	HP426	HP612	HU615		

Geometria rompitrucolo	Dimensione strutturale	Imbocco	Specifiche	Codice								
neutro	2	AS	WP-TEC2-ASE02LOA-...									
		EK **	WP-TEC2-EKE02LOA-...									
		DZ	WP-TEC2-DZE02LOA-...					31306931				
		R0,4 **	WP-TEC2-04E02LOA-...					31306932				

positivo	2	AS	WP-TEC2-ASF01L1G-...	31306933	30889440	31079651	31079651				31140267	
		EK **	WP-TEC2-EKF01L1G-...	30653470	30829191	30971023	30971023				30630537	
		DZ	WP-TEC2-DZF01L1G-...	31306937	31306938	31306940	31306940		31306941		31181002	
		R0,4 **	WP-TEC2-04F01L1J-...	31306945	31306947	31306949	31306949		31306950		31306951	

altamente positivo	2	AS	WP-TEC2-ASF01L1N-...							31306973		31306974
		EK **	WP-TEC2-EKF01L1N-...							31306977		31306978
		DZ	WP-TEC2-DZF01L1N-...							31306979		31306980
		R0,4 **	WP-TEC2-04F01L1U-...							31306981		31306982

** Nota: Utilizzare l'imbocco EK e R0,4 solo per la lavorazione di fori ciechi e sfacciatura in base ai requisiti dei componenti

Inserti a fissaggio meccanico per utensili per la lavorazione esterna

Materiale da taglio	Metallo duro									
GTM*	P				M	K		N		
	1.1 - 1.2	2 - 3 5	4 6	1 - 3	1.1	2 - 3	1.1 - 1.2	2.3	2.1 - 2.2	
Tipo di materiale da taglio	HP115	HP425	HP016	HP016	HC418	HP426	HP612	HU615		

Geometria rompitrucolo	Dimensione strutturale	Imbocco	Specifiche	Codice								
neutro	92	AS	WP-AS92L0-...									
		EK	WP-EK152L0-...									
		DZ	WP-DZ92L0-...					31301508				

positivo	92	AS	WP-AS92L6-...	30914125	30914127	31056555	31056555				30914124	
		EK	WP-EK152L6-...	30914554	31302302	31247603	31247603				30914553	
		DZ	WP-DZ92L6-...	31306923	31306925	31306926	31306926		31306927		30914421	

altamente positivo	92	AS	WP-AS92L2-...							31175426		30914120
		EK	WP-EK152L2-...							31301535		30914549
		DZ	WP-DZ92L2-...									

Tagliante con imbocco AS



Tagliante con imbocco EK



Tagliante con imbocco DZ



Metallo duro		
S		H
1 - 2		1.1
HU615		HP016

Cermet	
P	
1 - 3 5	
CP122	

PCD	
N	
1 - 2	
PU620	

PcBN		
K		H
1.1		1.1 - 1.2
FU485		FU801

Codice		

Codice	

Codice	

Codice		

30309015	
31301541	
31306928	

30914763**	
30914788**	

30914120		
30914549		

Accessori per utensili per la lavorazione esterna



Dimensione tagliente TEC	Cartucce lame per utensile di lavorazione esterna		Anelli di bloccaggio per utensile di lavorazione esterna	
	Specifiche	Codice	Specifiche	Codice
2	BC-EAS-L-42-B	30562954	CP-EAS-L-N2-B	30565468
2	BC-EAS-L-42-D	30558608	CP-EAS-L-N2-D	30560195
2	BC-EAS-L-42-F	30562956	CP-EAS-L-N2-F	30565469
2	BC-EAS-L-42-H	30562958	CP-EAS-L-N2-H	30565470
2	BC-EAS-L-42-K	30562959	CP-EAS-L-N2-K	30565472
2	BC-EAS-L-42-M	30562960	CP-EAS-L-N2-M	30565474
2	BC-EAS-L-42-P	30562963	CP-EAS-L-N2-P	30565475
2	BC-EAS-L-42-R	30562964	CP-EAS-L-N2-R	30565478
3	BC-EAS-L-43-B	30562965	CP-EAS-L-N3-B	30565479
3	BC-EAS-L-43-D	30562967	CP-EAS-L-N3-D	30565481
3	BC-EAS-L-43-F	30562968	CP-EAS-L-N3-F	30565483
3	BC-EAS-L-43-H	30562969	CP-EAS-L-N3-H	30565490
3	BC-EAS-L-43-K	30562970	CP-EAS-L-N3-K	30565491
3	BC-EAS-L-43-M	30562971	CP-EAS-L-N3-M	30565492
3	BC-EAS-L-43-P	30562972	CP-EAS-L-N3-P	30565494
3	BC-EAS-L-43-R	30562974	CP-EAS-L-N3-R	30565495



Parametri di lavorazione consigliati per utensili per la lavorazione esterna con inserti a fissaggio meccanico TEC

Avanzamento e velocità di taglio

TEC2-AS-L-HP115

GTM*	Materiale	Resistenza/durezza [N/mm ²] [HRC]	Velocità di taglio v_c (m/min)	Avanzamento f_z (mm/z)
			Adduzione interna del refrigerante	
P P1	P1.1 Acciai da costruzione, automatici, da cementazione e da bonifica, non legati	< 700	80	0,150
	P1.2 Acciai da costruzione, automatici, da cementazione e da bonifica, non legati	< 1200	70	0,150

TEC2-EK-L-HP115

GTM*	Materiale	Resistenza/durezza [N/mm ²] [HRC]	Velocità di taglio v_c (m/min)	Avanzamento f_z (mm/z)
			Adduzione interna del refrigerante	
P P1	P1.1 Acciai da costruzione, automatici, da cementazione e da bonifica, non legati	< 700	80	0,150
	P1.2 Acciai da costruzione, automatici, da cementazione e da bonifica, non legati	< 1200	70	0,150

TEC2-DZ-L-HP115

GTM*	Materiale	Resistenza/durezza [N/mm ²] [HRC]	Velocità di taglio v_c (m/min)	Avanzamento f_z (mm/z)
			Adduzione interna del refrigerante	
P P1	P1.1 Acciai da costruzione, automatici, da cementazione e da bonifica, non legati	< 700	80	0,150
	P1.2 Acciai da costruzione, automatici, da cementazione e da bonifica, non legati	< 1200	70	0,150

TEC2-04-L-HP115

GTM*	Materiale	Resistenza/durezza [N/mm ²] [HRC]	Velocità di taglio v_c (m/min)	Avanzamento f_z (mm/z)
			Adduzione interna del refrigerante	
P P1	P1.1 Acciai da costruzione, automatici, da cementazione e da bonifica, non legati	< 700	80	0,150
	P1.2 Acciai da costruzione, automatici, da cementazione e da bonifica, non legati	< 1200	70	0,150

TEC2-AS-L-HP425

GTM*	Materiale	Resistenza/durezza [N/mm ²] [HRC]	Velocità di taglio v_c (m/min)	Avanzamento f_z (mm/z)
			Adduzione interna del refrigerante	
P	P2.1 Acciai da nitrurazione, da cementazione e da bonifica, legati	< 900	100	0,150
	P2.2 Acciai da nitrurazione, da cementazione e da bonifica, legati	< 1400	80	0,150
	P3.1 Acciai per utensili, per cuscinetti volventi, armonici e per lavorazioni veloci**	< 900	100	0,150
	P3.2 Acciai per utensili, per cuscinetti volventi, armonici e per lavorazioni veloci**	< 1500	80	0,150
	P5.1 Acciaio fuso		80	0,150

* Gruppi di materiale MAPAL

** Qualora la somma dei componenti di lega Cr, Mo, Ni, V, W equivalesse a > 8%, selezionare il gruppo di materiale MAPAL immediatamente superiore.

TEC2-EK-L-HP425

GTM*	Materiale	Resistenza/durezza [N/mm ²] [HRC]	Velocità di taglio v_c (m/min)	Avanzamento f_z (mm/z)
			Adduzione interna del refrigerante	
P	P2.1	Acciai da nitrurazione, da cementazione e da bonifica, legati	100	0,150
	P2.2	Acciai da nitrurazione, da cementazione e da bonifica, legati	80	0,150
	P3.1	Acciai per utensili, per cuscinetti volventi, armonici e per lavorazioni veloci**	100	0,150
	P3.2	Acciai per utensili, per cuscinetti volventi, armonici e per lavorazioni veloci**	80	0,150
	P5.1	Acciaio fuso	80	0,150

TEC2-DZ-L-HP425

GTM*	Materiale	Resistenza/durezza [N/mm ²] [HRC]	Velocità di taglio v_c (m/min)	Avanzamento f_z (mm/z)
			Adduzione interna del refrigerante	
P	P2.1	Acciai da nitrurazione, da cementazione e da bonifica, legati	100	0,150
	P2.2	Acciai da nitrurazione, da cementazione e da bonifica, legati	80	0,150
	P3.1	Acciai per utensili, per cuscinetti volventi, armonici e per lavorazioni veloci**	100	0,150
	P3.2	Acciai per utensili, per cuscinetti volventi, armonici e per lavorazioni veloci**	80	0,150
	P5.1	Acciaio fuso	80	0,150

TEC2-04-L-HP425

GTM*	Materiale	Resistenza/durezza [N/mm ²] [HRC]	Velocità di taglio v_c (m/min)	Avanzamento f_z (mm/z)
			Adduzione interna del refrigerante	
P	P2.1	Acciai da nitrurazione, da cementazione e da bonifica, legati	100	0,150
	P2.2	Acciai da nitrurazione, da cementazione e da bonifica, legati	80	0,150
	P3.1	Acciai per utensili, per cuscinetti volventi, armonici e per lavorazioni veloci**	100	0,150
	P3.2	Acciai per utensili, per cuscinetti volventi, armonici e per lavorazioni veloci**	80	0,150
	P5.1	Acciaio fuso	80	0,150

TEC2-AS-L-HP016

GTM*	Materiale	Resistenza/durezza [N/mm ²] [HRC]	Velocità di taglio v_c (m/min)	Avanzamento f_z (mm/z)
			Adduzione interna del refrigerante	
P4	P4.1	Acciai inossidabili, ferritici e martensitici	50	0,120
	P6.1	Acciaio fuso, ferritico e martensitico	40	0,120
M	M1.1	Acciai inossidabili, austenitici	50	0,120
	M1.2	Acciai inossidabili, ferritici/austenitici (Duplex)	30	0,120
	M2.1	Acciaio fuso inossidabile, austenitico	50	0,120
M3	M3.1	Acciaio fuso inossidabile, ferritico/austenitico (Duplex)	30	0,120

I parametri di lavorazione indicati sono valori orientativi.

I dati ottimali per la specifica applicazione devono essere rilevati eseguendo diversi tentativi o durante l'effettiva lavorazione.

Parametri di lavorazione consigliati per utensili per la lavorazione esterna con inserti a fissaggio meccanico TEC

Avanzamento e velocità di taglio

TEC2-EK-L-HP016

GTM*	Materiale	Resistenza/durezza [N/mm ²] [HRC]	Velocità di taglio v_c (m/min)	Avanzamento f_z (mm/z)		
			Adduzione interna del refrigerante			
P4	P4.1	Acciai inossidabili, ferritici e martensitici	50	0,120		
	P6	P6.1	Acciaio fuso, ferritico e martensitico	40		
M	M1	M1.1	Acciai inossidabili, austenitici	< 700	50	0,120
		M1.2	Acciai inossidabili, ferritici/austenitici (Duplex)	< 1000	30	0,120
	M2	M2.1	Acciaio fuso inossidabile, austenitico	< 700	50	0,120
	M3	M3.1	Acciaio fuso inossidabile, ferritico/austenitico (Duplex)	< 1000	30	0,120

TEC2-DZ-L-HP016

GTM*	Materiale	Resistenza/durezza [N/mm ²] [HRC]	Velocità di taglio v_c (m/min)	Avanzamento f_z (mm/z)		
			Adduzione interna del refrigerante			
P4	P4.1	Acciai inossidabili, ferritici e martensitici	50	0,120		
	P6	P6.1	Acciaio fuso, ferritico e martensitico	40		
M	M1	M1.1	Acciai inossidabili, austenitici	< 700	50	0,120
		M1.2	Acciai inossidabili, ferritici/austenitici (Duplex)	< 1000	30	0,120
	M2	M2.1	Acciaio fuso inossidabile, austenitico	< 700	50	0,120
	M3	M3.1	Acciaio fuso inossidabile, ferritico/austenitico (Duplex)	< 1000	30	0,120

TEC2-04-L-HP016

GTM*	Materiale	Resistenza/durezza [N/mm ²] [HRC]	Velocità di taglio v_c (m/min)	Avanzamento f_z (mm/z)		
			Adduzione interna del refrigerante			
P4	P4.1	Acciai inossidabili, ferritici e martensitici	50	0,120		
	P6	P6.1	Acciaio fuso, ferritico e martensitico	40		
M	M1	M1.1	Acciai inossidabili, austenitici	< 700	50	0,120
		M1.2	Acciai inossidabili, ferritici/austenitici (Duplex)	< 1000	30	0,120
	M2	M2.1	Acciaio fuso inossidabile, austenitico	< 700	50	0,120
	M3	M3.1	Acciaio fuso inossidabile, ferritico/austenitico (Duplex)	< 1000	30	0,120

TEC2-DZ-L-HC418

GTM*	Materiale	Resistenza/durezza [N/mm ²] [HRC]	Velocità di taglio v_c (m/min)	Avanzamento f_z (mm/z)		
			Adduzione interna del refrigerante			
K	K1	K1.1	Ghisa con grafite lamellare (ghisa grigia), GJL	< 300	100	0,150

* Gruppi di materiale MAPAL

TEC2-04-L-HC418

GTM*	Materiale	Resistenza/durezza [N/mm ²] [HRC]	Velocità di taglio v_c (m/min)	Avanzamento f_z (mm/z)
			Adduzione interna del refrigerante	
K K1 K1.1	Ghisa con grafite lamellare (ghisa grigia), GJL	< 300	100	0,150

TEC2-DZ-L-HP426

GTM*	Materiale	Resistenza/durezza [N/mm ²] [HRC]	Velocità di taglio v_c (m/min)	Avanzamento f_z (mm/z)
			Adduzione interna del refrigerante	
K2	K2.1 Ghisa con grafite sferoidale, GJS	< 500	100	0,150
	K2.2 Ghisa con grafite sferoidale, GJS	≤ 800	90	0,150
	K2.3 Ghisa con grafite sferoidale, GJS	> 800	80	0,150
K3	K3.1 Ghisa con grafite vermicolare, GJV; acciaio fuso malleabile, GJM	< 500	70	0,150
	K3.2 Ghisa con grafite vermicolare, GJV; acciaio fuso malleabile, GJM	> 500	70	0,150

TEC2-04-L-HP426

GTM*	Materiale	Resistenza/durezza [N/mm ²] [HRC]	Velocità di taglio v_c (m/min)	Avanzamento f_z (mm/z)
			Adduzione interna del refrigerante	
K2	K2.1 Ghisa con grafite sferoidale, GJS	< 500	100	0,150
	K2.2 Ghisa con grafite sferoidale, GJS	≤ 800	90	0,150
	K2.3 Ghisa con grafite sferoidale, GJS	> 800	80	0,150
K3	K3.1 Ghisa con grafite vermicolare, GJV; acciaio fuso malleabile, GJM	< 500	70	0,150
	K3.2 Ghisa con grafite vermicolare, GJV; acciaio fuso malleabile, GJM	> 500	70	0,150

TEC2-AS-L-HP612

GTM*	Materiale	Resistenza/durezza [N/mm ²] [HRC]	Velocità di taglio v_c (m/min)	Avanzamento f_z (mm/z)
			Adduzione interna del refrigerante	
N N1	N1.1 Alluminio, non legato e legato < 3% Si		160	0,150
	N1.2 Alluminio, legato ≤ 7% Si		160	0,150

TEC2-EK-L-HP612

GTM*	Materiale	Resistenza/durezza [N/mm ²] [HRC]	Velocità di taglio v_c (m/min)	Avanzamento f_z (mm/z)
			Adduzione interna del refrigerante	
N N1	N1.1 Alluminio, non legato e legato < 3% Si		160	0,150
	N1.2 Alluminio, legato ≤ 7% Si		160	0,150

I parametri di lavorazione indicati sono valori orientativi.

I dati ottimali per la specifica applicazione devono essere rilevati eseguendo diversi tentativi o durante l'effettiva lavorazione.

Parametri di lavorazione consigliati per utensili per la lavorazione esterna con inserti a fissaggio meccanico TEC

Avanzamento e velocità di taglio

TEC2-DZ-L-HP612

GTM*	Materiale	Resistenza/durezza [N/mm ²] [HRC]	Velocità di taglio v_c (m/min)	Avanzamento f_z (mm/z)
			Adduzione interna del refrigerante	
N N1	N1.1 Alluminio, non legato e legato < 3% Si		160	0,150
	N1.2 Alluminio, legato ≤ 7% Si		160	0,150

TEC2-04-L-HP612

GTM*	Materiale	Resistenza/durezza [N/mm ²] [HRC]	Velocità di taglio v_c (m/min)	Avanzamento f_z (mm/z)
			Adduzione interna del refrigerante	
N N1	N1.1 Alluminio, non legato e legato < 3% Si		160	0,150
	N1.2 Alluminio, legato ≤ 7% Si		160	0,150

TEC2-AS-L-HU615

GTM*	Materiale	Resistenza/durezza [N/mm ²] [HRC]	Velocità di taglio v_c (m/min)	Avanzamento f_z (mm/z)
			Adduzione interna del refrigerante	
N N2	N2.1 Rame, non legato e bassolegato	< 300	100	0,150
	N2.2 Rame, legato	> 300	100	0,150
	N2.3 Ottone, bronzo, ghisa rossa	< 1200	100	0,150
S S1	S1.1 Titanio, leghe di titanio	< 400	30	0,120
	S2.1 Titanio, leghe di titanio	< 1200	20	0,120
	S2.2 Titanio, leghe di titanio	> 1200	20	0,100

TEC2-EK-L-HU615

GTM*	Materiale	Resistenza/durezza [N/mm ²] [HRC]	Velocità di taglio v_c (m/min)	Avanzamento f_z (mm/z)
			Adduzione interna del refrigerante	
N N2	N2.1 Rame, non legato e bassolegato	< 300	100	0,150
	N2.2 Rame, legato	> 300	100	0,150
	N2.3 Ottone, bronzo, ghisa rossa	< 1200	100	0,150
S S1	S1.1 Titanio, leghe di titanio	< 400	30	0,120
	S2.1 Titanio, leghe di titanio	< 1200	20	0,120
	S2.2 Titanio, leghe di titanio	> 1200	20	0,100

* Gruppi di materiale MAPAL

** Qualora la somma dei componenti di lega Cr, Mo, Ni, V, W equivalesse a > 8%, selezionare il gruppo di materiale MAPAL immediatamente superiore.

TEC2-DZ-L-HU615

GTM*		Materiale	Resistenza/durezza [N/mm ²] [HRC]	Velocità di taglio v_c (m/min)	Avanzamento f_z (mm/z)	
				Adduzione interna del refrigerante		
N	N2	N2.1	Rame, non legato e bassolegato	< 300	100	0,150
		N2.2	Rame, legato	> 300	100	0,150
		N2.3	Ottone, bronzo, ghisa rossa	< 1200	100	0,150
S	S2	S2.1	Titanio, leghe di titanio	< 400	30	0,120
		S2.1	Titanio, leghe di titanio	< 1200	20	0,120
		S2.2	Titanio, leghe di titanio	> 1200	20	0,100

TEC2-04-L-HU615

GTM*		Materiale	Resistenza/durezza [N/mm ²] [HRC]	Velocità di taglio v_c (m/min)	Avanzamento f_z (mm/z)	
				Adduzione interna del refrigerante		
N	N2	N2.1	Rame, non legato e bassolegato	< 300	100	0,150
		N2.2	Rame, legato	> 300	100	0,150
		N2.3	Ottone, bronzo, ghisa rossa	< 1200	100	0,150
S	S2	S2.1	Titanio, leghe di titanio	< 400	30	0,120
		S2.1	Titanio, leghe di titanio	< 1200	20	0,120
		S2.2	Titanio, leghe di titanio	> 1200	20	0,100

TEC2-AS-L-CP122

GTM*		Materiale	Resistenza/durezza [N/mm ²] [HRC]	Velocità di taglio v_c (m/min)	Avanzamento f_z (mm/z)	
				Adduzione interna del refrigerante		
P1	P1	P1.1	Acciai da costruzione, automatici, da cementazione e da bonifica, non legati	< 700	180	0,150
		P1.2	Acciai da costruzione, automatici, da cementazione e da bonifica, non legati	< 1200	160	0,120
P2	P2	P2.1	Acciai da nitrurazione, da cementazione e da bonifica, legati	< 900	160	0,150
		P2.2	Acciai da nitrurazione, da cementazione e da bonifica, legati	< 1400	140	0,120
P3	P3	P3.1	Acciai per utensili, per cuscinetti volventi, armonici e per lavorazioni veloci**	< 800	160	0,150
		P3.2	Acciai per utensili, per cuscinetti volventi, armonici e per lavorazioni veloci**	< 1000	160	0,150
		P3.3	Acciai per utensili, per cuscinetti volventi, armonici e per lavorazioni veloci**	< 1500	140	0,120
P5	P5.1	Acciaio fuso		140	0,120	

I parametri di lavorazione indicati sono valori orientativi.

I dati ottimali per la specifica applicazione devono essere rilevati eseguendo diversi tentativi o durante l'effettiva lavorazione.

Parametri di lavorazione consigliati per utensili per la lavorazione esterna con inserti a fissaggio meccanico TEC

Avanzamento e velocità di taglio

TEC2-EK-L-CP122

GTM*	Materiale	Resistenza/durezza [N/mm ²] [HRC]	Velocità di taglio v_c (m/min)	Avanzamento f_z (mm/z)
			Adduzione interna del refrigerante	
P	P1.1	Acciai da costruzione, automatici, da cementazione e da bonifica, non legati	180	0,150
	P1.2	Acciai da costruzione, automatici, da cementazione e da bonifica, non legati	160	0,120
	P2.1	Acciai da nitrurazione, da cementazione e da bonifica, legati	160	0,150
	P2.2	Acciai da nitrurazione, da cementazione e da bonifica, legati	140	0,120
	P3.1	Acciai per utensili, per cuscinetti volventi, armonici e per lavorazioni veloci**	160	0,150
	P3.2	Acciai per utensili, per cuscinetti volventi, armonici e per lavorazioni veloci**	160	0,150
	P3.3	Acciai per utensili, per cuscinetti volventi, armonici e per lavorazioni veloci**	140	0,120
	P5	P5.1 Acciaio fuso	140	0,120

TEC2-DZ-L-CP122

GTM*	Materiale	Resistenza/durezza [N/mm ²] [HRC]	Velocità di taglio v_c (m/min)	Avanzamento f_z (mm/z)
			Adduzione interna del refrigerante	
P	P1.1	Acciai da costruzione, automatici, da cementazione e da bonifica, non legati	180	0,150
	P1.2	Acciai da costruzione, automatici, da cementazione e da bonifica, non legati	160	0,120
	P2.1	Acciai da nitrurazione, da cementazione e da bonifica, legati	160	0,150
	P2.2	Acciai da nitrurazione, da cementazione e da bonifica, legati	140	0,120
	P3.1	Acciai per utensili, per cuscinetti volventi, armonici e per lavorazioni veloci**	160	0,150
	P3.2	Acciai per utensili, per cuscinetti volventi, armonici e per lavorazioni veloci**	160	0,150
	P3.3	Acciai per utensili, per cuscinetti volventi, armonici e per lavorazioni veloci**	140	0,120
	P5	P5.1 Acciaio fuso	140	0,120

TEC2-04-L-CP122

GTM*	Materiale	Resistenza/durezza [N/mm ²] [HRC]	Velocità di taglio v_c (m/min)	Avanzamento f_z (mm/z)
			Adduzione interna del refrigerante	
P	P1.1	Acciai da costruzione, automatici, da cementazione e da bonifica, non legati	180	0,150
	P1.2	Acciai da costruzione, automatici, da cementazione e da bonifica, non legati	160	0,120
	P2.1	Acciai da nitrurazione, da cementazione e da bonifica, legati	160	0,150
	P2.2	Acciai da nitrurazione, da cementazione e da bonifica, legati	140	0,120
	P3.1	Acciai per utensili, per cuscinetti volventi, armonici e per lavorazioni veloci**	160	0,150
	P3.2	Acciai per utensili, per cuscinetti volventi, armonici e per lavorazioni veloci**	160	0,150
	P3.3	Acciai per utensili, per cuscinetti volventi, armonici e per lavorazioni veloci**	140	0,120
	P5	P5.1 Acciaio fuso	140	0,120

* Gruppi di materiale MAPAL

** Qualora la somma dei componenti di lega Cr, Mo, Ni, V, W equivalesse a > 8%, selezionare il gruppo di materiale MAPAL immediatamente superiore.

TEC2-AS-L-PU620

GTM*	Materiale	Resistenza/durezza [N/mm ²] [HRC]	Velocità di taglio v_c (m/min)	Avanzamento f_z (mm/z)
			Adduzione interna del refrigerante	
N	N1	N1.1 Alluminio, non legato e legato < 3% Si	230	0,150
		N1.2 Alluminio, legato ≤ 7% Si	230	0,150
		N1.3 Alluminio, legato > 7-12% Si	230	0,150
		N1.4 Alluminio, legato > 12% Si	230	0,150
N	N2	N2.1 Rame, non legato e bassolegato	< 300	0,150
		N2.2 Rame, legato	> 300	0,150
		N2.3 Ottone, bronzo, ghisa rossa	< 1200	0,150

TEC2-EK-L-PU620

GTM*	Materiale	Resistenza/durezza [N/mm ²] [HRC]	Velocità di taglio v_c (m/min)	Avanzamento f_z (mm/z)
			Adduzione interna del refrigerante	
N	N1	N1.1 Alluminio, non legato e legato < 3% Si	230	0,150
		N1.2 Alluminio, legato ≤ 7% Si	230	0,150
		N1.3 Alluminio, legato > 7-12% Si	230	0,150
		N1.4 Alluminio, legato > 12% Si	230	0,150
N	N2	N2.1 Rame, non legato e bassolegato	< 300	0,150
		N2.2 Rame, legato	> 300	0,150
		N2.3 Ottone, bronzo, ghisa rossa	< 1200	0,150

TEC2-DZ-L-PU620

GTM*	Materiale	Resistenza/durezza [N/mm ²] [HRC]	Velocità di taglio v_c (m/min)	Avanzamento f_z (mm/z)
			Adduzione interna del refrigerante	
N	N1	N1.1 Alluminio, non legato e legato < 3% Si	230	0,150
		N1.2 Alluminio, legato ≤ 7% Si	230	0,150
		N1.3 Alluminio, legato > 7-12% Si	230	0,150
		N1.4 Alluminio, legato > 12% Si	230	0,150
N	N2	N2.1 Rame, non legato e bassolegato	< 300	0,150
		N2.2 Rame, legato	> 300	0,150
		N2.3 Ottone, bronzo, ghisa rossa	< 1200	0,150

TEC2-04-L-PU620

GTM*	Materiale	Resistenza/durezza [N/mm ²] [HRC]	Velocità di taglio v_c (m/min)	Avanzamento f_z (mm/z)
			Adduzione interna del refrigerante	
N	N1	N1.1 Alluminio, non legato e legato < 3% Si	230	0,150
		N1.2 Alluminio, legato ≤ 7% Si	230	0,150
		N1.3 Alluminio, legato > 7-12% Si	230	0,150
		N1.4 Alluminio, legato > 12% Si	230	0,150
N	N2	N2.1 Rame, non legato e bassolegato	< 300	0,150
		N2.2 Rame, legato	> 300	0,150
		N2.3 Ottone, bronzo, ghisa rossa	< 1200	0,150

I parametri di lavorazione indicati sono valori orientativi.

I dati ottimali per la specifica applicazione devono essere rilevati eseguendo diversi tentativi o durante l'effettiva lavorazione.

Parametri di lavorazione consigliati per utensili per la lavorazione esterna con inserti a fissaggio meccanico

Avanzamento e velocità di taglio

AS-L-HP115

GTM*	Materiale	Resistenza/durezza [N/mm ²] [HRC]	Velocità di taglio v_c (m/min)	Avanzamento f_z (mm/z)	
			Adduzione interna del refrigerante		
P P1	P1.1	Acciai da costruzione, automatici, da cementazione e da bonifica, non legati	< 700	80	0,150
	P1.2	Acciai da costruzione, automatici, da cementazione e da bonifica, non legati	< 1200	70	0,150

EK-L-HP115

GTM*	Materiale	Resistenza/durezza [N/mm ²] [HRC]	Velocità di taglio v_c (m/min)	Avanzamento f_z (mm/z)	
			Adduzione interna del refrigerante		
P P1	P1.1	Acciai da costruzione, automatici, da cementazione e da bonifica, non legati	< 700	80	0,150
	P1.2	Acciai da costruzione, automatici, da cementazione e da bonifica, non legati	< 1200	70	0,150

DZ-L-HP115

GTM*	Materiale	Resistenza/durezza [N/mm ²] [HRC]	Velocità di taglio v_c (m/min)	Avanzamento f_z (mm/z)	
			Adduzione interna del refrigerante		
P P1	P1.1	Acciai da costruzione, automatici, da cementazione e da bonifica, non legati	< 700	80	0,150
	P1.2	Acciai da costruzione, automatici, da cementazione e da bonifica, non legati	< 1200	70	0,150

AS-L-HP425

GTM*	Materiale	Resistenza/durezza [N/mm ²] [HRC]	Velocità di taglio v_c (m/min)	Avanzamento f_z (mm/z)		
			Adduzione interna del refrigerante			
P	P2	P2.1	Acciai da nitrurazione, da cementazione e da bonifica, legati	< 900	100	0,150
		P2.2	Acciai da nitrurazione, da cementazione e da bonifica, legati	< 1400	80	0,150
	P3	P3.1	Acciai per utensili, per cuscinetti volventi, armonici e per lavorazioni veloci**	< 900	100	0,150
		P3.2	Acciai per utensili, per cuscinetti volventi, armonici e per lavorazioni veloci**	< 1500	80	0,150
	P5	P5.1	Acciaio fuso		80	0,150

* Gruppi di materiale MAPAL

** Qualora la somma dei componenti di lega Cr, Mo, Ni, V, W equivalesse a > 8%, selezionare il gruppo di materiale MAPAL immediatamente superiore.

EK-L-HP425

GTM*	Materiale	Resistenza/durezza [N/mm ²] [HRC]	Velocità di taglio v_c (m/min)	Avanzamento f_z (mm/z)	
			Adduzione interna del refrigerante		
P	P2.1	Acciai da nitrurazione, da cementazione e da bonifica, legati	< 900	100	0,150
	P2.2	Acciai da nitrurazione, da cementazione e da bonifica, legati	< 1400	80	0,150
	P3.1	Acciai per utensili, per cuscinetti volventi, armonici e per lavorazioni veloci**	< 900	100	0,150
	P3.2	Acciai per utensili, per cuscinetti volventi, armonici e per lavorazioni veloci**	< 1500	80	0,150
	P5.1	Acciaio fuso		80	0,150

DZ-L-HP425

GTM*	Materiale	Resistenza/durezza [N/mm ²] [HRC]	Velocità di taglio v_c (m/min)	Avanzamento f_z (mm/z)	
			Adduzione interna del refrigerante		
P	P2.1	Acciai da nitrurazione, da cementazione e da bonifica, legati	< 900	100	0,150
	P2.2	Acciai da nitrurazione, da cementazione e da bonifica, legati	< 1400	80	0,150
	P3.1	Acciai per utensili, per cuscinetti volventi, armonici e per lavorazioni veloci**	< 900	100	0,150
	P3.2	Acciai per utensili, per cuscinetti volventi, armonici e per lavorazioni veloci**	< 1500	80	0,150
	P5.1	Acciaio fuso		80	0,150

AS-L-HP016

GTM*	Materiale	Resistenza/durezza [N/mm ²] [HRC]	Velocità di taglio v_c (m/min)	Avanzamento f_z (mm/z)	
			Adduzione interna del refrigerante		
P4	P4.1	Acciai inossidabili, ferritici e martensitici	50	0,120	
	P6.1	Acciaio fuso, ferritico e martensitico	40	0,120	
M	M1.1	Acciai inossidabili, austenitici	< 700	50	0,120
	M1.2	Acciai inossidabili, ferritici/austenitici (Duplex)	< 1000	30	0,120
	M2.1	Acciaio fuso inossidabile, austenitico	< 700	50	0,120
M3	M3.1	Acciaio fuso inossidabile, ferritico/austenitico (Duplex)	< 1000	30	0,120

EK-L-HP016

GTM*	Materiale	Resistenza/durezza [N/mm ²] [HRC]	Velocità di taglio v_c (m/min)	Avanzamento f_z (mm/z)	
			Adduzione interna del refrigerante		
P4	P4.1	Acciai inossidabili, ferritici e martensitici	50	0,120	
	P6.1	Acciaio fuso, ferritico e martensitico	40	0,120	
M	M1.1	Acciai inossidabili, austenitici	< 700	50	0,120
	M1.2	Acciai inossidabili, ferritici/austenitici (Duplex)	< 1000	30	0,120
	M2.1	Acciaio fuso inossidabile, austenitico	< 700	50	0,120
M3	M3.1	Acciaio fuso inossidabile, ferritico/austenitico (Duplex)	< 1000	30	0,120

I parametri di lavorazione indicati sono valori orientativi.

I dati ottimali per la specifica applicazione devono essere rilevati eseguendo diversi tentativi o durante l'effettiva lavorazione.

Parametri di lavorazione consigliati per utensili per la lavorazione esterna con inserti a fissaggio meccanico

Avanzamento e velocità di taglio

DZ-L-HP016

GTM*	Materiale	Resistenza/durezza [N/mm ²] [HRC]	Velocità di taglio v_c (m/min)	Avanzamento f_z (mm/z)		
			Adduzione interna del refrigerante			
P4	P4.1	Acciai inossidabili, ferritici e martensitici	50	0,120		
	P6	P6.1	Acciaio fuso, ferritico e martensitico	40	0,120	
M	M1	M1.1	Acciai inossidabili, austenitici	< 700	50	0,120
		M1.2	Acciai inossidabili, ferritici/austenitici (Duplex)	< 1000	30	0,120
	M2	M2.1	Acciaio fuso inossidabile, austenitico	< 700	50	0,120
	M3	M3.1	Acciaio fuso inossidabile, ferritico/austenitico (Duplex)	< 1000	30	0,120

DZ-L-HC418

GTM*	Materiale	Resistenza/durezza [N/mm ²] [HRC]	Velocità di taglio v_c (m/min)	Avanzamento f_z (mm/z)		
			Adduzione interna del refrigerante			
K	K1	K1.1	Ghisa con grafite lamellare (ghisa grigia), GJL	< 300	100	0,150

DZ-L-HP426

GTM*	Materiale	Resistenza/durezza [N/mm ²] [HRC]	Velocità di taglio v_c (m/min)	Avanzamento f_z (mm/z)		
			Adduzione interna del refrigerante			
K2	K2	K2.1	Ghisa con grafite sferoidale, GJS	< 500	100	0,150
		K2.2	Ghisa con grafite sferoidale, GJS	≤ 800	90	0,150
		K2.3	Ghisa con grafite sferoidale, GJS	> 800	80	0,150
K3	K3	K3.1	Ghisa con grafite vermicolare, GJV; acciaio fuso malleabile, GJM	< 500	70	0,150
		K3.2	Ghisa con grafite vermicolare, GJV; acciaio fuso malleabile, GJM	> 500	70	0,150

AS-L-HP612

GTM*	Materiale	Resistenza/durezza [N/mm ²] [HRC]	Velocità di taglio v_c (m/min)	Avanzamento f_z (mm/z)	
			Adduzione interna del refrigerante		
N	N1	N1.1	Alluminio, non legato e legato < 3% Si	160	0,150
		N1.2	Alluminio, legato ≤ 7% Si	160	0,150

EK-L-HP612

GTM*	Materiale	Resistenza/durezza [N/mm ²] [HRC]	Velocità di taglio v_c (m/min)	Avanzamento f_z (mm/z)	
			Adduzione interna del refrigerante		
N	N1	N1.1	Alluminio, non legato e legato < 3% Si	160	0,150
		N1.2	Alluminio, legato ≤ 7% Si	160	0,150

* Gruppi di materiale MAPAL

AS-L-HU615

GTM*		Materiale	Resistenza/durezza [N/mm ²] [HRC]	Velocità di taglio v_c (m/min)	Avanzamento f_z (mm/z)	
				Adduzione interna del refrigerante		
N	N2	N2.1	Rame, non legato e bassolegato	< 300	100	0,150
		N2.2	Rame, legato	> 300	100	0,150
		N2.3	Ottone, bronzo, ghisa rossa	< 1200	100	0,150
S	S2	S2.1	Titanio, leghe di titanio	< 400	30	0,120
		S2.1	Titanio, leghe di titanio	< 1200	20	0,120
		S2.2	Titanio, leghe di titanio	> 1200	20	0,100

EK-L-HU615

GTM*		Materiale	Resistenza/durezza [N/mm ²] [HRC]	Velocità di taglio v_c (m/min)	Avanzamento f_z (mm/z)	
				Adduzione interna del refrigerante		
N	N2	N2.1	Rame, non legato e bassolegato	< 300	100	0,150
		N2.2	Rame, legato	> 300	100	0,150
		N2.3	Ottone, bronzo, ghisa rossa	< 1200	100	0,150
S	S2	S2.1	Titanio, leghe di titanio	< 400	30	0,120
		S2.1	Titanio, leghe di titanio	< 1200	20	0,120
		S2.2	Titanio, leghe di titanio	> 1200	20	0,100

DZ-L-HU615

GTM*		Materiale	Resistenza/durezza [N/mm ²] [HRC]	Velocità di taglio v_c (m/min)	Avanzamento f_z (mm/z)	
				Adduzione interna del refrigerante		
N	N2	N2.1	Rame, non legato e bassolegato	< 300	100	0,150
		N2.2	Rame, legato	> 300	100	0,150
		N2.3	Ottone, bronzo, ghisa rossa	< 1200	100	0,150

I parametri di lavorazione indicati sono valori orientativi.

I dati ottimali per la specifica applicazione devono essere rilevati eseguendo diversi tentativi o durante l'effettiva lavorazione.

Parametri di lavorazione consigliati per utensili per la lavorazione esterna con inserti a fissaggio meccanico

Avanzamento e velocità di taglio

AS-L-CP122

GTM*	Materiale	Resistenza/durezza [N/mm ²] [HRC]	Velocità di taglio v_c (m/min)	Avanzamento f_z (mm/z)	
			Adduzione interna del refrigerante		
P	P1	P1.1 Acciai da costruzione, automatici, da cementazione e da bonifica, non legati	< 700	180	0,150
		P1.2 Acciai da costruzione, automatici, da cementazione e da bonifica, non legati	< 1200	160	0,120
	P2	P2.1 Acciai da nitrurazione, da cementazione e da bonifica, legati	< 900	160	0,150
		P2.2 Acciai da nitrurazione, da cementazione e da bonifica, legati	< 1400	140	0,120
	P3	P3.1 Acciai per utensili, per cuscinetti volventi, armonici e per lavorazioni veloci**	< 800	160	0,150
		P3.2 Acciai per utensili, per cuscinetti volventi, armonici e per lavorazioni veloci**	< 1000	160	0,150
		P3.3 Acciai per utensili, per cuscinetti volventi, armonici e per lavorazioni veloci**	< 1500	140	0,120
	P5	P5.1 Acciaio fuso		140	0,120

EK-L-CP122

GTM*	Materiale	Resistenza/durezza [N/mm ²] [HRC]	Velocità di taglio v_c (m/min)	Avanzamento f_z (mm/z)	
			Adduzione interna del refrigerante		
P	P1	P1.1 Acciai da costruzione, automatici, da cementazione e da bonifica, non legati	< 700	180	0,150
		P1.2 Acciai da costruzione, automatici, da cementazione e da bonifica, non legati	< 1200	160	0,120
	P2	P2.1 Acciai da nitrurazione, da cementazione e da bonifica, legati	< 900	160	0,150
		P2.2 Acciai da nitrurazione, da cementazione e da bonifica, legati	< 1400	140	0,120
	P3	P3.1 Acciai per utensili, per cuscinetti volventi, armonici e per lavorazioni veloci**	< 800	160	0,150
		P3.2 Acciai per utensili, per cuscinetti volventi, armonici e per lavorazioni veloci**	< 1000	160	0,150
		P3.3 Acciai per utensili, per cuscinetti volventi, armonici e per lavorazioni veloci**	< 1500	140	0,120
	P5	P5.1 Acciaio fuso		140	0,120

DZ-L-CP122

GTM*	Materiale	Resistenza/durezza [N/mm ²] [HRC]	Velocità di taglio v_c (m/min)	Avanzamento f_z (mm/z)	
			Adduzione interna del refrigerante		
P	P1	P1.1 Acciai da costruzione, automatici, da cementazione e da bonifica, non legati	< 700	180	0,150
		P1.2 Acciai da costruzione, automatici, da cementazione e da bonifica, non legati	< 1200	160	0,120
	P2	P2.1 Acciai da nitrurazione, da cementazione e da bonifica, legati	< 900	160	0,150
		P2.2 Acciai da nitrurazione, da cementazione e da bonifica, legati	< 1400	140	0,120
	P3	P3.1 Acciai per utensili, per cuscinetti volventi, armonici e per lavorazioni veloci**	< 800	160	0,150
		P3.2 Acciai per utensili, per cuscinetti volventi, armonici e per lavorazioni veloci**	< 1000	160	0,150
		P3.3 Acciai per utensili, per cuscinetti volventi, armonici e per lavorazioni veloci**	< 1500	140	0,120
	P5	P5.1 Acciaio fuso		140	0,120

* Gruppi di materiale MAPAL

** Qualora la somma dei componenti di lega Cr, Mo, Ni, V, W equivalesse a > 8%, selezionare il gruppo di materiale MAPAL immediatamente superiore.

AS-L-PU620

GTM*	Materiale	Resistenza/durezza [N/mm ²] [HRC]	Velocità di taglio v_c (m/min)	Avanzamento f_z (mm/z)	
			Adduzione interna del refrigerante		
N	N1	N1.1 Alluminio, non legato e legato < 3% Si	230	0,150	
		N1.2 Alluminio, legato ≤ 7% Si	230	0,150	
		N1.3 Alluminio, legato > 7-12% Si	230	0,150	
		N1.4 Alluminio, legato > 12% Si	230	0,150	
	N2	N2.1 Rame, non legato e bassolegato	< 300	180	0,150
		N2.2 Rame, legato	> 300	180	0,150
		N2.3 Ottone, bronzo, ghisa rossa	< 1200	180	0,150

EK-L-PU620

GTM*	Materiale	Resistenza/durezza [N/mm ²] [HRC]	Velocità di taglio v_c (m/min)	Avanzamento f_z (mm/z)	
			Adduzione interna del refrigerante		
N	N1	N1.1 Alluminio, non legato e legato < 3% Si	230	0,150	
		N1.2 Alluminio, legato ≤ 7% Si	230	0,150	
		N1.3 Alluminio, legato > 7-12% Si	230	0,150	
		N1.4 Alluminio, legato > 12% Si	230	0,150	
	N2	N2.1 Rame, non legato e bassolegato	< 300	180	0,150
		N2.2 Rame, legato	> 300	180	0,150
		N2.3 Ottone, bronzo, ghisa rossa	< 1200	180	0,150

I parametri di lavorazione indicati sono valori orientativi.

I dati ottimali per la specifica applicazione devono essere rilevati eseguendo diversi tentativi o durante l'effettiva lavorazione.

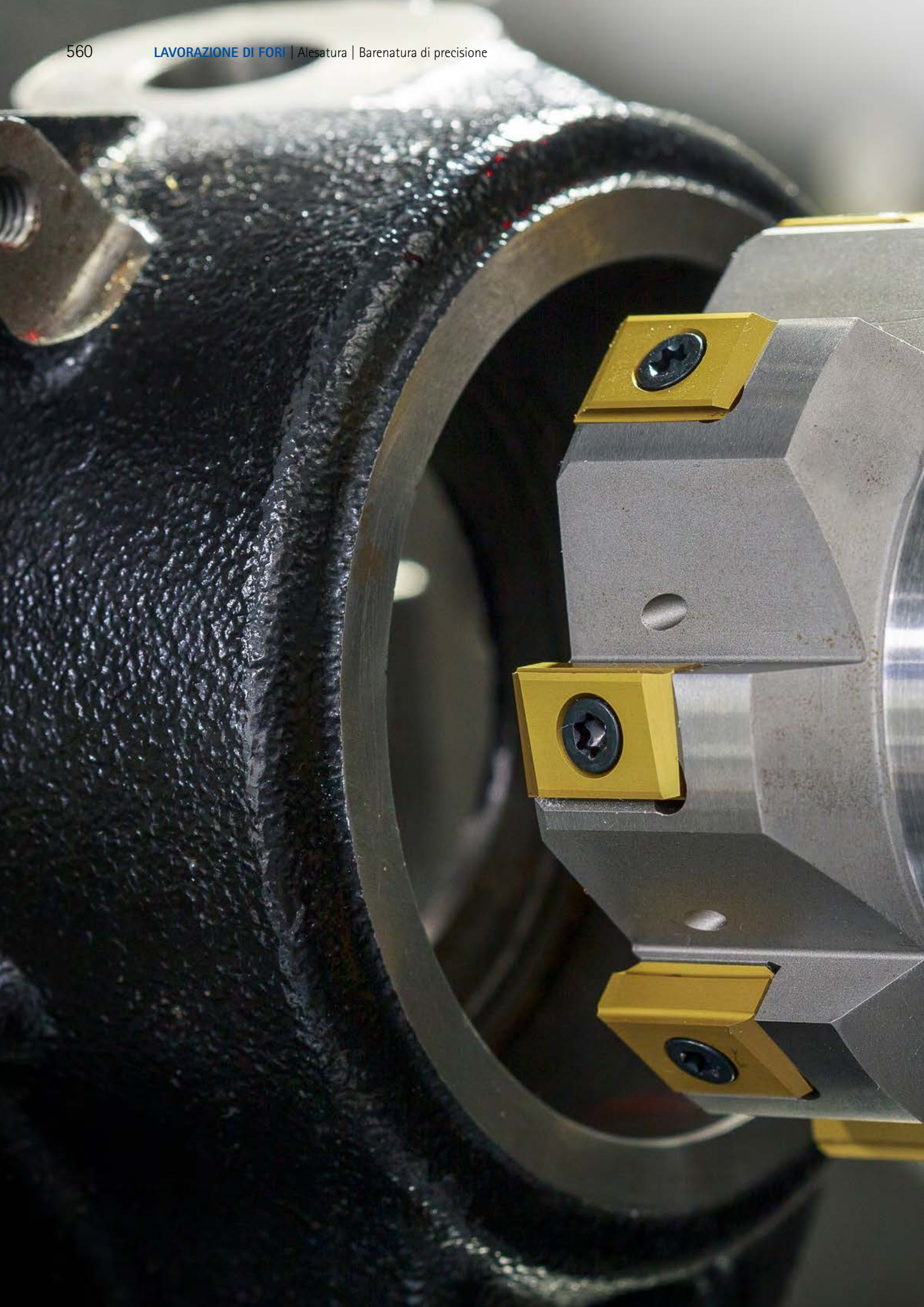



SOLUZIONI PER GRANDI DIAMETRI | SOLUZIONI SPECIALI

Soluzioni per grandi diametri

Panoramica prodotti	562
HPR400 plus	564
HPR400	568

Soluzioni speciali

Utensili con pattini di guida	572
Utensili con sistema EasyAdjust	574
Alesatori a più taglienti	576



PANORAMICA PRODOTTI

Alesatori a più taglienti ad alte prestazioni per grandi range di diametro

Per la lavorazione fine di fori con grande diametro nel rispetto di una tolleranza predefinita, spesso gli utenti si pongono una domanda cruciale: alesatura o mandrino? Gli utensili di alesatura a più taglienti consentono di lavorare molto più velocemente e sono inoltre meno sensibili ai tagli interrotti. D'altra parte, però, la preparazione degli alesatori con taglienti fissi è un processo piuttosto oneroso.

Al fine di ottimizzare il processo di ricondizionamento, MAPAL propone due diversi sistemi HPR:

HPR400 plus

Lo sviluppo degli alesatori HPR400 plus si è incentrato sull'incremento della redditività grazie a un ricondizionamento efficiente. Gli utensili a più taglienti conquistano infatti per la loro elevata redditività, posta in essere da dati di impiego particolarmente rapidi e dalla semplice sostituzione del tagliente, che può essere operata dal cliente direttamente sul posto. Tutto questo grazie a sedi dell'inserito altamente precise. Questo consente di far decadere totalmente i costi di logistica per il trasporto fino al produttore. Gli utensili impiegati e costi di ricondizionamento sono contenuti al livello minimo. Gli inserti a fissaggio meccanico con quattro taglienti garantiscono uno sfruttamento ottimale del materiale da taglio.

HPR400

Semplice sostituzione dei taglienti sul posto

Al fine di ridurre il numero di utensili necessari e le scorte a magazzino, MAPAL propone il sistema HPR400, che consente al cliente di eseguire la sostituzione dei taglienti in proprio, direttamente sul posto. I corpi base non devono essere sottoposti a ricondizionamento: l'unico onere riguarda quindi lo stoccaggio a magazzino dei taglienti necessari.



HPR

**HPR400 plus**

Quattro taglienti per un'elevata redditività e convenienza.

- Nessun costo logistico per il trasporto fino al produttore per il ricondizionamento
- Tolleranza IT7 realizzabile a partire da diametro 65,000 mm

Range di \varnothing : 63,000 - 319,999 mm

Expert
LINE



P M K N

**HPR400**

Semplice sostituzione dei taglienti sul posto.

- Un eventuale montaggio errato è escluso, poiché i taglienti possono essere montati in qualsiasi posizione.

Range di \varnothing : 63,000 - 319,999 mm

Expert
LINE



P M K N

HPR400 plus

Nessuna necessità di preimpostazione e i quattro taglienti riducono sensibilmente il Cost-per-Part

L'incremento della redditività mediante un ricondizionamento efficiente era lo scopo principale a cui mirava lo sviluppo degli alesatori HPR400. Gli utensili a più taglienti conquistano infatti per la loro elevata redditività, posta in essere da dati di impiego particolarmente rapidi e dalla semplice sostituzione del tagliente, che può essere operata dal cliente direttamente sul posto. Tutto questo grazie a sedi dell'inserto altamente precise. Questo consente di far decadere totalmente i costi di logistica per il trasporto fino al produttore. Gli utensili impiegati e costi di ricondizionamento sono contenuti al livello minimo.

Per incrementare ulteriormente la redditività nella lavorazione di grandi diametri, gli inserti dell'innovativo HPR400 plus non vengono più realizzati con un unico tagliente, ma sono dotati di ben quattro taglienti. Questo consente di sfruttare il materiale da taglio in modo ottimale. Gli inserti a fissaggio meccanico a quattro taglienti vengono prodotti con una precisione tale da consentirne la semplice sostituzione o l'agevole

ribaltamento direttamente sul posto a cura dei collaboratori del cliente.

È possibile ridurre ulteriormente le scorte a magazzino di taglienti, abbassando i costi di ricondizionamento e il Cost-per-Part.

IN SINTESI

- Sostituzione del tagliente direttamente sul posto a cura del cliente
- Quattro taglienti al posto dell'unico tagliente finora presente
- Range di diametro da 63,000 a 319,999 mm
- Impiego universale con tutti i materiali
- Il materiale da taglio viene sfruttato in modo ottimale
- Nessun costo logistico per il trasporto fino al produttore per il ricondizionamento
- Meno utensili impiegati e costi di ricondizionamento ridotti
- Semplice ribaltamento e sostituzione degli inserti

Caratteristiche utensile nel dettaglio

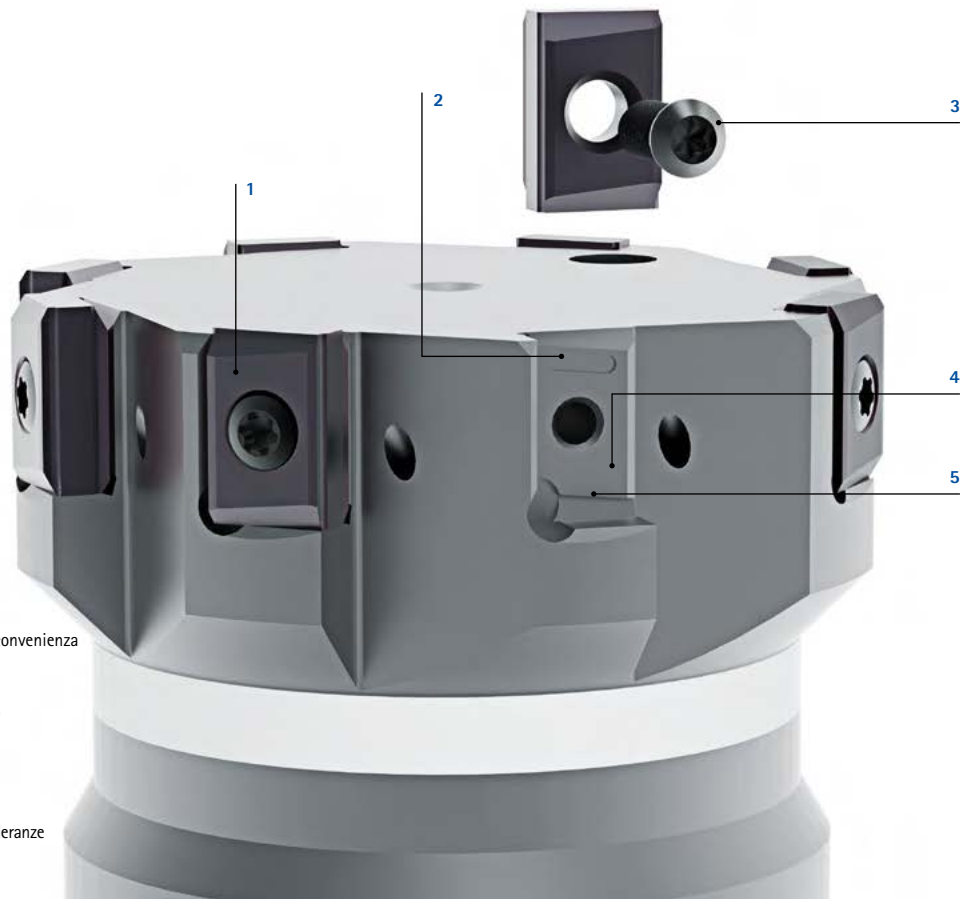

1 Inserto

A quattro taglienti per un'elevata redditività e convenienza

2 Tasca di sfregamento

Per la rimozione delle micro-particelle di sporco

3 Vite TORX® PLUS

4 Sede dell'inserto

Altamente precisa per il rispetto ottimale delle tolleranze

5 Scanalatura per lo sporco

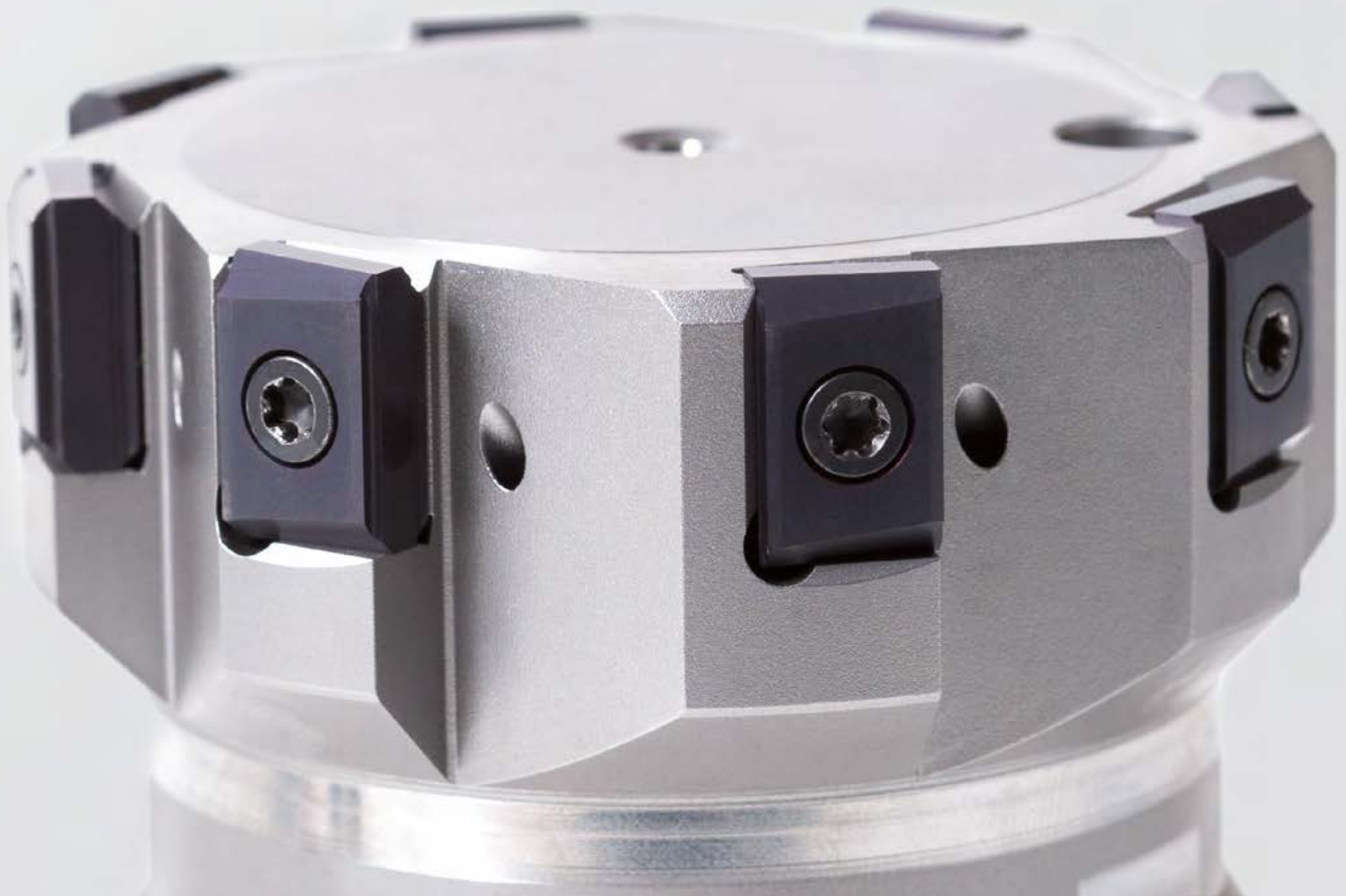

HPR400 plus



Sostituzione del tagliente direttamente sul posto a cura del cliente

- Facile utilizzo
- Sostituzione del tagliente altamente precisa grazie alla sede dell'inserto ad alta precisione
- Nessuna necessità di presettaggio



Quattro taglienti per un'elevata redditività e convenienza

- Disponibilità di diversi materiali da taglio e imbrocchi
- Lavorazioni speciali disponibili su richiesta

IT10	Green				
IT9	Green				
IT8	Yellow				
IT7	Yellow				
IT6	Red				
IT5	Red				
IT4	Red				
	65,001 - 80,000	80,001 - 120,000	120,001 - 180,000	180,001 - 250,000	250,001 - 315,000

Tolleranza IT7 a partire da diametro 65 mm

- La classe di tolleranza IT7 può essere ottenuta senza problemi in caso di grandi diametri; tolleranze inferiori sono possibili con diametri maggiori

Alesatore ad alte prestazioni HPR400 plus

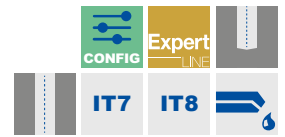
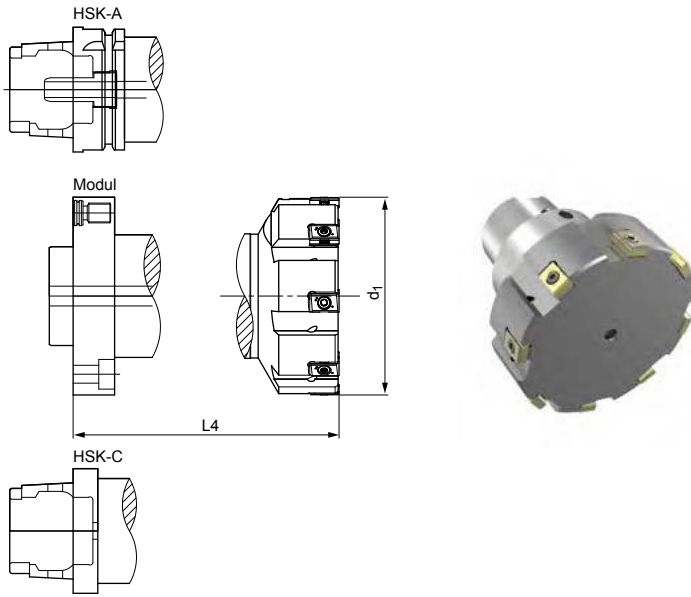

Dimensioni corpo base HPR400 plus

d ₁	z	Dimensione sede				
		HSK-C	HSK-A	Lunghezza della proiezione L4 a libera scelta	Modulo	Lunghezza della proiezione L4 a libera scelta
63,000 - 79,999	8	HSK-C063	HSK-A063	65-290	60	65-320
80,000 - 99,999	8	HSK-C063	HSK-A063	65-290	80	65-320
100,000 - 124,999	8	HSK-C080	HSK-A080	75-330	100	75-320
125,000 - 159,999	8	HSK-C080	HSK-A080	75-330	100	75-320
160,000 - 199,999	8	HSK-C080	HSK-A080	75-330	140	90-320
200,000 - 249,999	10	HSK-C100	HSK-A100	90-300	140	90-320
250,000 - 319,999	12	HSK-C100	HSK-A100	90-300	140	90-320

I dati forniti sono meri valori orientativi, deviazioni su richiesta

Caratteristiche configurabili



- Diametro a libera scelta a passi da 0,001 mm
- Ordinabile a partire da tolleranze IT7 - IT8 (min. 40 µm)
- Tutti gli attacchi disponibili come innesto
- Realizzabile come utensile a gradini
- abbinabile ad altri sistemi di utensili e attacchi MAPAL
- Compatibile con lubrificazione minimale

Specifiche:
Su richiesta

Accessori e pezzi di ricambio	Codice materiale
Set chiave dinamometrica 1 - 5 Nm	30415174
Vite di ricambio M4x12	10018468

Misure in mm.

Altri imbocchi e materiali da taglio su richiesta.

Inserti a fissaggio meccanico per HPR400 plus



Taglienti - Serie selezionata

Range di diametro	Codice materiale
63,000 - 79,999	30968871
80,000 - 99,999	30933385
100,000 - 124,999	30968884
125,000 - 159,999	30968891
160,000 - 199,999	30968898
200,000 - 249,999	30968905
250,000 - 319,999	30968912

Versione:

Range di diametro: 63,000 - 319,999
 Quattro taglienti
 Imbocco: 45° x 0,55 mm
 Materiale da taglio: HC419



Taglienti - Serie selezionata

Range di diametro	Codice materiale
63,000 - 79,999	31315612
80,000 - 99,999	31315613
100,000 - 124,999	31149561
125,000 - 159,999	31315614
160,000 - 199,999	31315615
200,000 - 249,999	31315617
250,000 - 319,999	31315618

Versione:

Range di diametro: 63,000 - 319,999
 Quattro taglienti
 Imbocco: 30° x 0,60 mm +
 angolo di spoglia
 Materiale da taglio: CP004
 Categoria di materiali K
 Idoneità per superfici Ra < 2 µm

Misure in mm.

Altri imbocchi e materiali da taglio su richiesta.

HPR400

Alesare grandi diametri con una semplice sostituzione dei taglienti direttamente sul posto

Grazie a speciali sedi degli inserti ad alta precisione, con la serie HPR400 gli utenti possono sostituire i taglienti autonomamente e direttamente sul posto, utilizzando semplicemente una chiave dinamometrica. Un eventuale montaggio errato è escluso, poiché è possibile un'unica posizione di installazione e i taglienti possono essere montati in qualsiasi posizione. In questo modo decade non solo il costo della regolazione, ma vengono meno anche le forniture per la riaffilatura e ricondizionamento. Basterà infatti che gli utenti abbiano a magazzino i taglienti MAPAL. Il numero di utensili necessari è ridotto, poiché non è necessaria la preparazione del corpo base. Utilizzando l'HPR400, l'utente potrà ottenere fori di alta precisione con un onere minimo e pochi utensili.

I taglienti vengono adattati in modo ottimale in base al materiale e alla specifica lavorazione. La serie HPR400 è disponibile con un range

di diametro da 63 a 319,999 mm, con attacco HSK oppure con sede modulo propria MAPAL. MAPAL propone diverse tipologie di inserto in metallo duro, con o senza rivestimento CVD, con riporto in cermet, PCD o PcBN.

IN SINTESI

- Sostituzione autonoma del tagliente, effettuata dall'utilizzatore direttamente sul posto
- Assegnazione dei taglienti a prescindere dalla sede dell'inserto
- Riduzione del cost-per-part
- Ridotti costi di rivestimento
- Riduzione della quantità di utensili in lavorazione
- Possibilità di utilizzare tutti i materiali da taglio
- Tolleranza H7
- Ø 63,000 – 319,999 mm

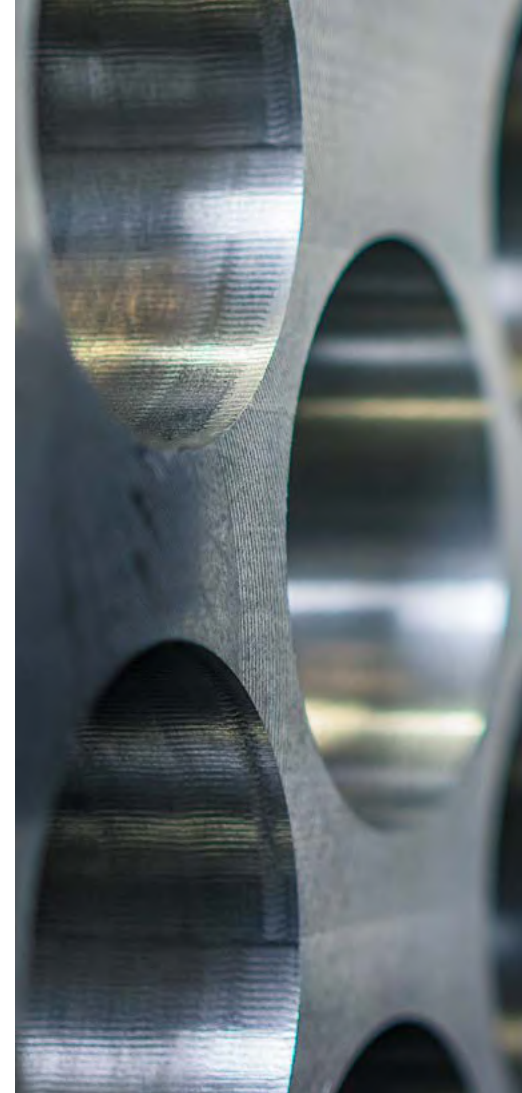

Caratteristiche utensile nel dettaglio

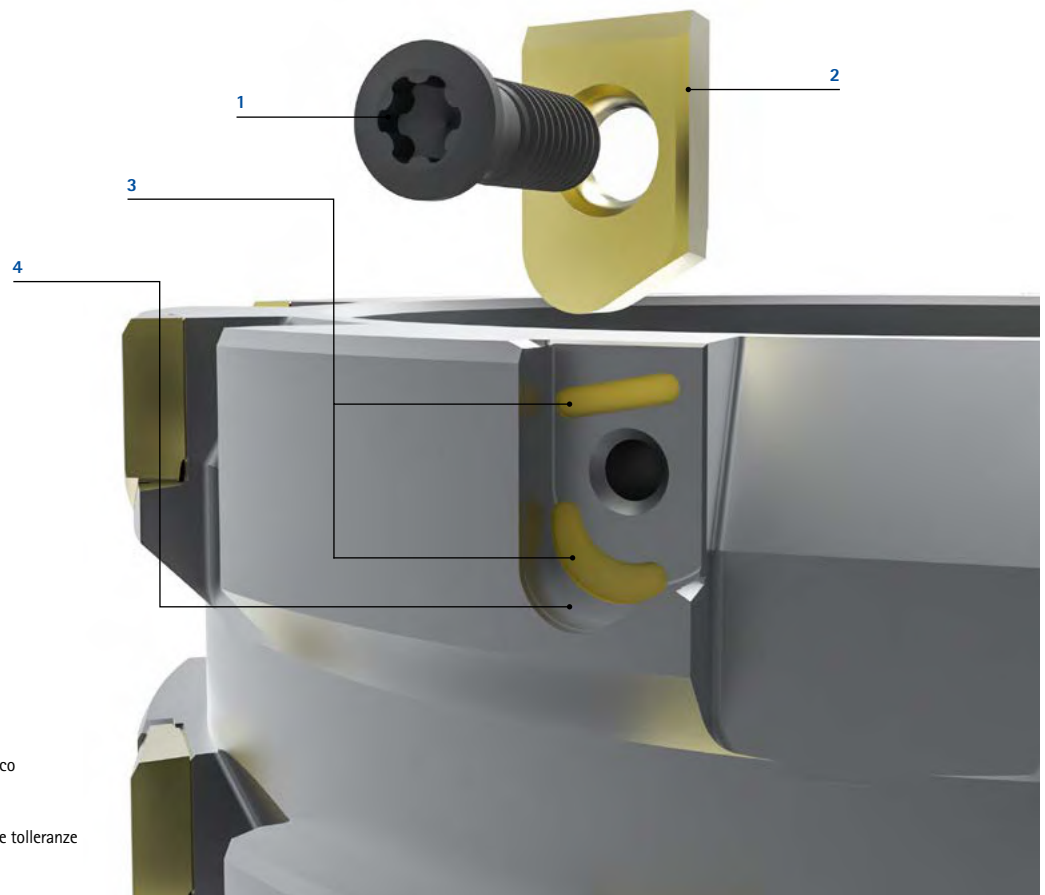

1 Vite di serraggio TORX®

2 Tagliente

Forma prismatica per un appoggio ottimale

3 Tasca di sfregamento

Per la rimozione delle micro-particelle di sporco

4 Sede dell'inserto

Altamente precisa per il rispetto ottimale delle tolleranze

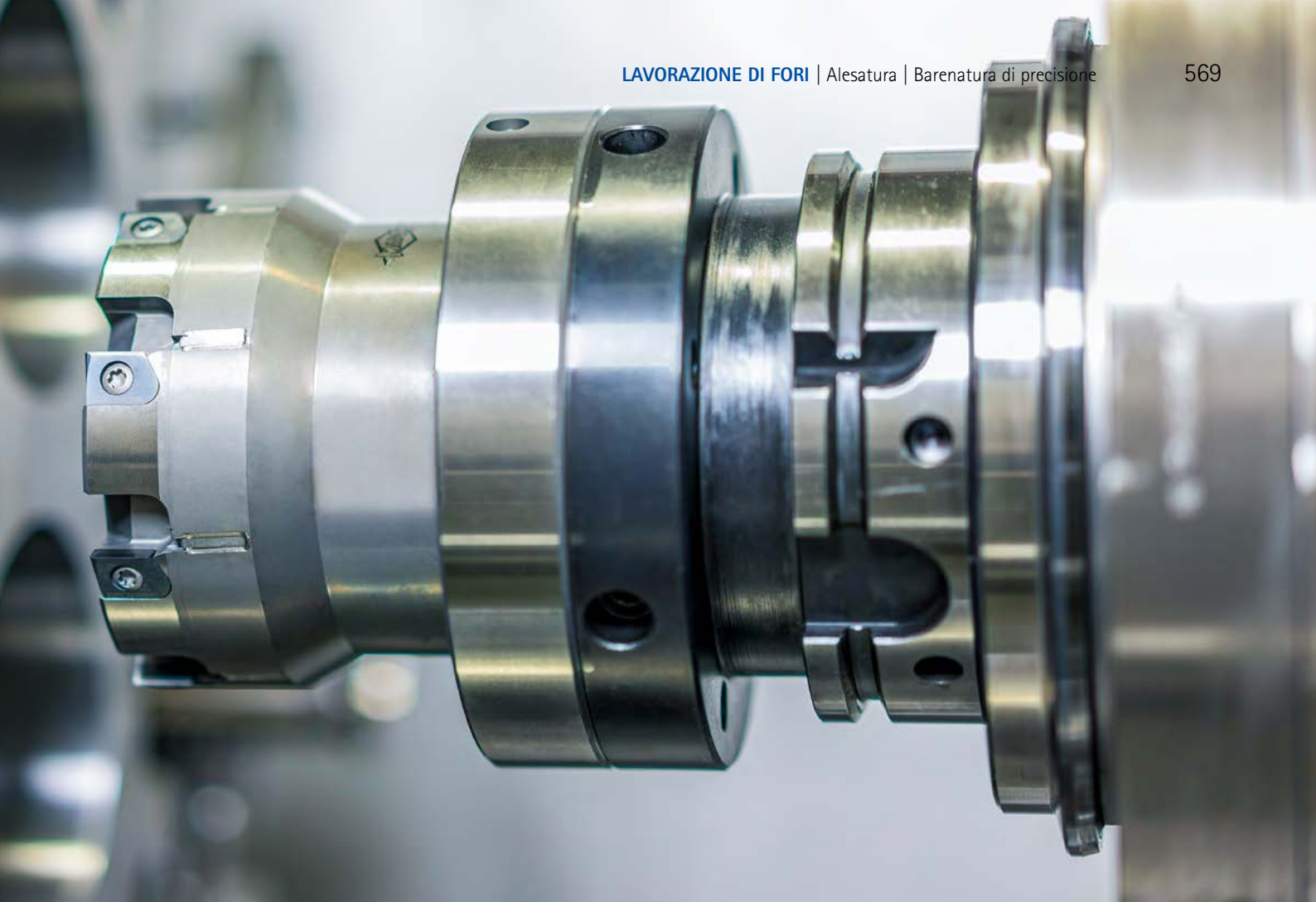

Taglienti rivestiti in CVD



Realizzazione ottimale per l'alesatura di materiali in ghisa

I materiali da taglio rivestiti in CVD disponibili per la serie HPR400, riconoscibili dalla sigla del materiale da taglio HC, sono stati sviluppati specificamente per l'alesatura di materiali duri in ghisa, quali GJL, GJS e GJV, in condizioni di lavorazione difficili, come ad esempio nel caso di taglio interrotto. Il rivestimento CVD si distingue per l'elevata tenacità e una buona resistenza all'usura. I taglienti rivestiti in PVD consentono infatti di ottenere durate fino a tre volte maggiori rispetto ai taglienti con rivestimento in CVD, mantenendo sempre elevata la sicurezza dei processi. Grazie allo speciale sistema di serraggio, con la serie HPR400 è possibile utilizzare anche praticamente tutti gli altri materiali da taglio.

Sistema economicamente conveniente



Semplice sostituzione dei taglienti sul posto

Con la serie HPR400, MAPAL propone un sistema che consente al cliente di eseguire la sostituzione dei taglienti in modo autonomo direttamente sul posto. I taglienti sostituibili vengono inseriti in senso assiale nella sede dell'inserto, per poi essere fissati nella rispettiva sede mediante una vite Torx, in modo sicuro e altamente preciso. L'assegnazione dei taglienti è indipendente dalla sede dell'inserto. I costi relativi al rivestimento vengono sensibilmente ridotti, al pari della quantità di utensili in lavorazione.

Alesatore ad alte prestazioni HPR400

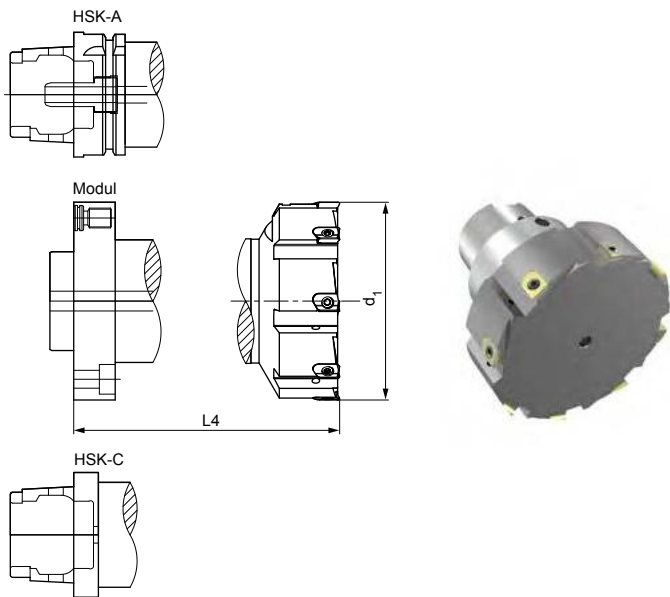

Dimensioni corpo base HPR400

d ₁	z	Dimensione sede				
		HSK-C	HSK-A	Lunghezza della proiezione L4 a libera scelta	Modulo	Lunghezza della proiezione L4 a libera scelta
63,000 - 79,999	8	HSK-C063	HSK-A063	65-290	60	65-320
80,000 - 99,999	8	HSK-C063	HSK-A063	65-290	80	65-320
100,000 - 124,999	8	HSK-C080	HSK-A080	75-330	100	75-320
125,000 - 159,999	8	HSK-C080	HSK-A080	75-330	100	75-320
160,000 - 199,999	8	HSK-C080	HSK-A080	75-330	140	90-320
200,000 - 249,999	10	HSK-C100	HSK-A100	90-300	140	90-320
250,000 - 319,999	12	HSK-C100	HSK-A100	90-300	140	90-320

I dati forniti sono meri valori orientativi, deviazioni su richiesta

Caratteristiche configurabili



- Diametro a libera scelta a passi da 0,001 mm
- Ordinabile a partire da tolleranza IT7
- Possibilità di taglio frontale
- Tutti gli attacchi disponibili come innesto
- Realizzabile come utensile a gradini
- abbinabile ad altri sistemi di utensili e attacchi MAPAL
- Compatibile con lubrificazione minimale

Specifiche:
Su richiesta



Accessori e pezzi di ricambio	Codice materiale
Set chiave dinamometrica 1 - 5 Nm	30415174
Vite di ricambio M3,5x9	10105078

Misure in mm.

Altri imbrocchi e materiali da taglio su richiesta.

Inserti per HPR400



Taglienti - Serie selezionata

Range di diametro	Codice materiale
63,000 - 79,999	30916603
80,000 - 99,999	30794390
100,000 - 124,999	30809550
125,000 - 159,999	30788089
160,000 - 199,999	30809531
200,000 - 249,999	30938712
250,000 - 319,999	30931640

Versione:

Range di diametro: 63,000 - 319,999

Un tagliente

Imbocco: 45° x 0,55 mm

Materiale da taglio: HC419



Taglienti - Serie selezionata

Range di diametro	Codice materiale
63,00 - 79,99	31026872
80,00 - 99,99	31129899
100,00 - 124,99	31049249
125,00 - 159,99	30690096
160,00 - 199,99	31149706
200,00 - 249,99	31149707
250,00 - 319,99	31129911

Versione:

Range di diametro: 63,000 - 319,999

Un tagliente

Imbocco: 30° x 0,60 mm +
angolo di spoglia

Materiale da taglio: CP004

Categoria di materiali K

Idoneità per superfici Ra < 2 µm

Misure in mm.

Altri imbrocchi e materiali da taglio su richiesta.

SOLUZIONI SPECIALI

Utensili con pattini di guida

Soluzioni di utensili specifiche per l'applicazione

- 1 Utensile di barenatura con pattini di guida, con cartuccia ISO in struttura leggera in alluminio, per la lavorazione di una scatola della trasmissione
- 2 Utensile per barenatura di precisione con sistema a inserti a fissaggio meccanico, per la lavorazione interna ed esterna combinata di un supporto planetario
- 3 Alesatore esterno con sistema EasyAdjust e taglienti TEC, per la lavorazione di un collettore di gas di scarico con supporto oscillante MAPAL
- 4 Utensile per barenatura di precisione con gradino di pre-taglio ISO e innesto per testa di alesatura HPR per la lavorazione di un blocco cilindri
- 5 Utensile per barenatura di precisione con sistema EasyAdjust e taglienti HX per la lavorazione di un foro dei cuscinetti dell'albero motore
- 6 Utensile per barenatura di precisione in struttura leggera e costruzione saldata per la lavorazione di una scatola della trasmissione
- 7 Utensile per barenatura di precisione a più gradini e a più taglienti in struttura leggera in titanio per la lavorazione di una scatola dello sterzo
- 8 Utensile per barenatura di precisione con sistema a inserti a fissaggio meccanico, progettato per lubrificazione minimale (MQL) e destinato alla lavorazione dell'involucro di un cursore di commutazione
- 9 Utensile per barenatura di precisione a più gradini con sistema a inserti a fissaggio meccanico, con taglienti perimetrali per la sfacciatura dell'involucro di una pompa
- 10 Utensile per barenatura di precisione con sistema a inserti a fissaggio meccanico, per la lavorazione combinata di un supporto planetario
- 11 Utensile per barenatura di precisione tangenziale, per la lavorazione di semifinitura con testa di taglio modulare, per la lavorazione di un foro dei cuscinetti dell'albero motore
- 12 Alesatore esterno con sistema a inserti a fissaggio meccanico realizzato in struttura leggera tramite stampa additiva, per la lavorazione di un perno del cursore di commutazione, realizzato in struttura leggera tramite produzione additiva



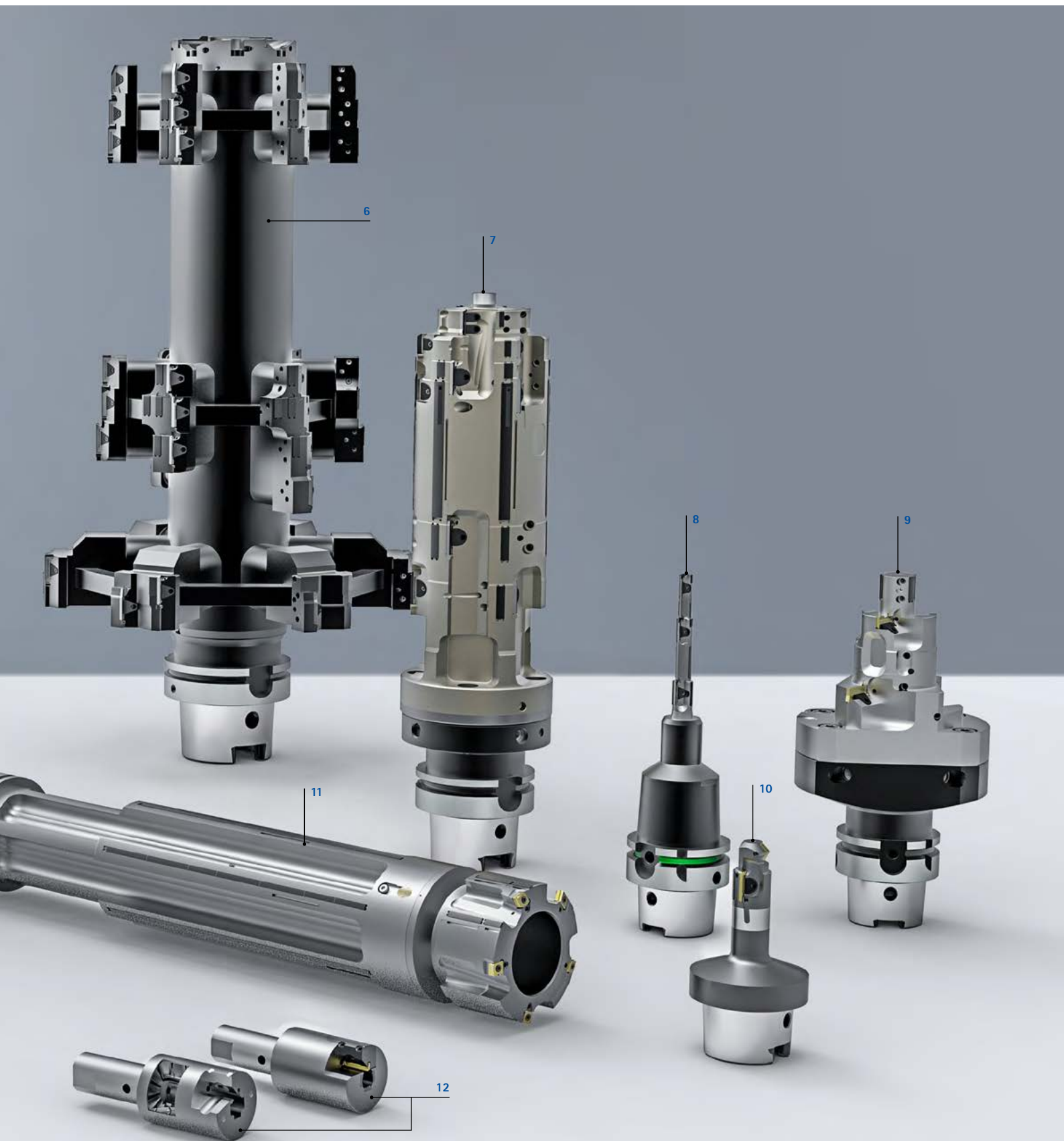

SOLUZIONI SPECIALI

Utensili con sistema EasyAdjust

Soluzioni speciali con sistema EasyAdjust

- 1 Utensili combinati per la lavorazione di preparazione e di finitura dell'occhiello grande e piccolo della biella. Con taglienti ISO per la lavorazione preliminare e sistema EasyAdjust per la finitura
- 2 Strumento personalizzato con sistema EasyAdjust con quattro taglienti TEC ($z = 4$) e pattini di guida allineati da un lato, per la lavorazione con taglio fortemente interrotto dell'involucro di una pompa in GJS-400
- 3 Utensile a sei taglienti con ripartizione del taglio 4+2 con sistema EasyAdjust e taglienti HX per la lavorazione di un foro cilindrico
- 4 Utensili per barenatura di precisione a più gradini con sistema EasyAdjust e taglienti TEC per la lavorazione di fori ciechi in scatole del cambio e delle valvole, con requisiti di precisione dimensionale IT5 e IT6
- 5 Utensili per la semifinitura e la finitura del foro di un cuscinetto per albero a gomito in esecuzione bimetallo alluminio-GJL
- 6 L'alesatore esterno con sistema EasyAdjust e taglienti TEC sostituisce la tradizionale tornitura di un componente in GJS con una maggiore precisione dimensionale





SOLUZIONI SPECIALI

Alesatori a più taglienti



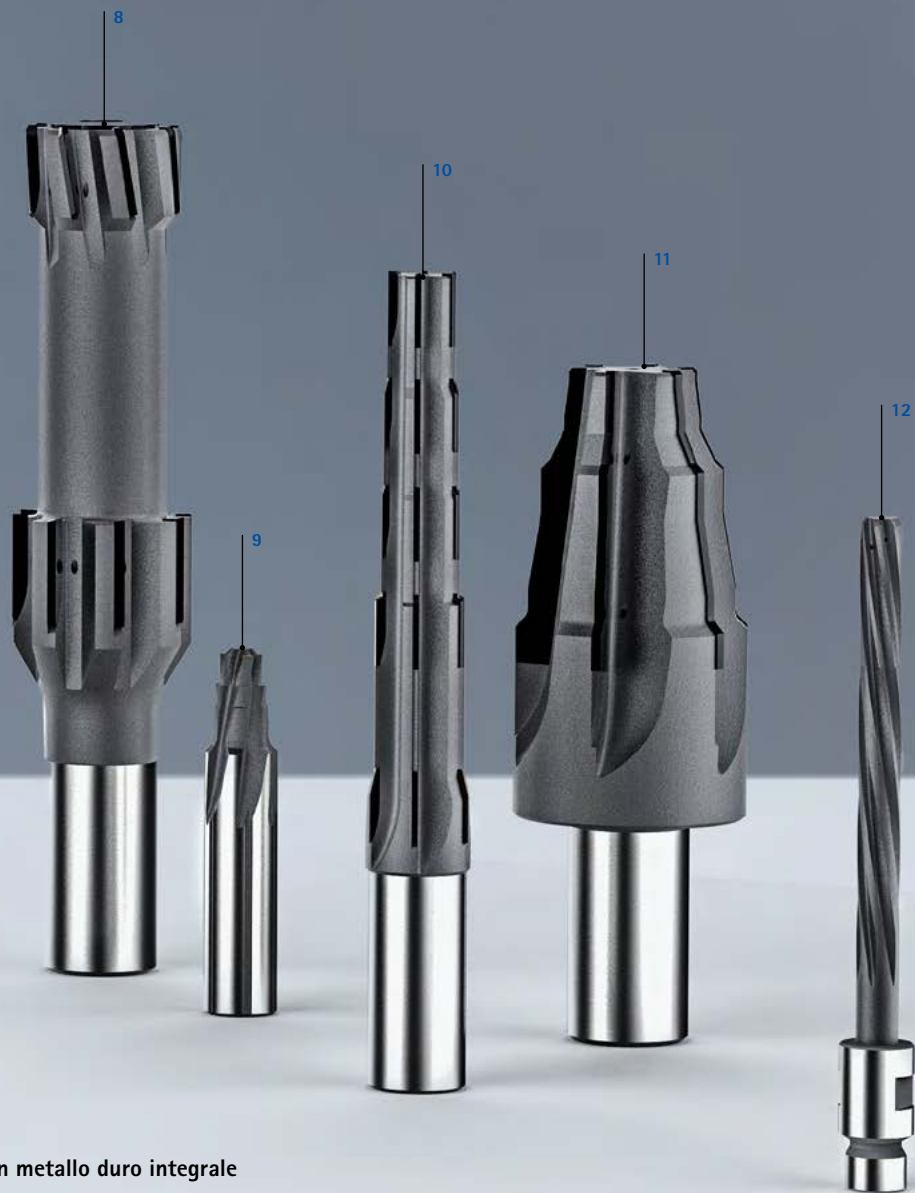

Soluzioni speciali per utensili in metallo duro integrale

- 1 Strumento personalizzato a due gradini con taglienti brasati, per la lavorazione dell'alloggiamento di unità idrauliche in EN-GJS-500-7
- 2 Strumento personalizzato a più gradini in metallo duro integrale rivestito, con lavorazione del raggio e dello smusso per l'asportazione truciolo di un supporto per cilindro in acciaio
- 3 Alesatore a gradini in metallo duro integrale rivestito, per la lavorazione di un foro per iniettore nella testa del cilindro
- 4 Alesatore a gradini in metallo duro integrale rivestito per la finitura del profilo di un foro per candele di accensione in EN-GJL-250
- 5 Alesatore a due gradini in metallo duro integrale con lavorazione aggiuntiva dello smusso per asportazione truciolo di una pompa ad alta pressione in acciaio inossidabile
- 6 Alesatore conico HSS per macchine con codolo MK
- 7 Alesatore a gradini in metallo duro integrale con geometria VA per la lavorazione di un blocco valvole in acciaio inossidabile
- 8 Alesatore speciale a due gradini con taglienti in cermet brasati, con versione combinata a scanalatura dritta e obliqua sinistra
- 9 Alesatore in metallo duro integrale rivestito a più gradini, con adduzione interna del refrigerante presso il codolo, per la lavorazione di un rail
- 10 Alesatore a gradini con taglienti in cermet semicirculari brasati integrati, per la lavorazione di un supporto ugello in acciaio
- 11 Alesatore sagomato rivestito con riporto in metallo duro integrale, per la lavorazione di elementi rotanti speciali
- 12 Alesatore ad alte prestazioni con testa in metallo duro integrale brasata e smussata, con sede speciale per il settore dell'aeronautica, per la lavorazione di una combinazione di fori per rivetti in titanio, alluminio e acciaio altolegato

SOLUZIONI SPECIALI

HPR - High-Performance-Reamer





Soluzioni speciali HPR

- 1 Soluzione speciale con anello HPR a più taglienti modulare e alesatore a gradini in metallo duro integrale, con supporto realizzato in stampa additiva con tecnica di espansione idraulica, per il serraggio interno ed esterno per la lavorazione della sede delle valvole
- 2 Utensile combinato modulare a più gradini con attacco CFS integrato per un tensile CPR fisso brasato con taglienti tangenziali ISO per la lavorazione preliminare e sistema HPR300 per la finitura di una pinza del freno
- 3 Strumento personalizzato a più gradini con riporto in PCD e gradino di svasatura per la lavorazione di un componente dell'industria aeronautica
- 4 Strumento personalizzato HPR a più gradini con innesto HFS per la lavorazione del foro e la svasatura del profilo di un turbocompressore in GJL250
- 5 Strumento personalizzato a più gradini per la lavorazione di involucri con taglienti di alesatura disposti in senso tangenziale
- 6 Strumento personalizzato per la lavorazione di un foro per rivetti nell'industria aeronautica
- 7 Utensile a taglio destro per la lavorazione di fori ciechi
- 8 Strumento personalizzato a più gradini con speciali geometrie dei taglienti e innesto HFS
- 9 Strumento personalizzato in versione fissa con taglienti brasati, per la lavorazione di gradini nei passaggi in piano e con smussi del foro per attuatore nella pinza del freno

SOLUZIONI SPECIALI

Alesatori a più taglienti per grandi diametri

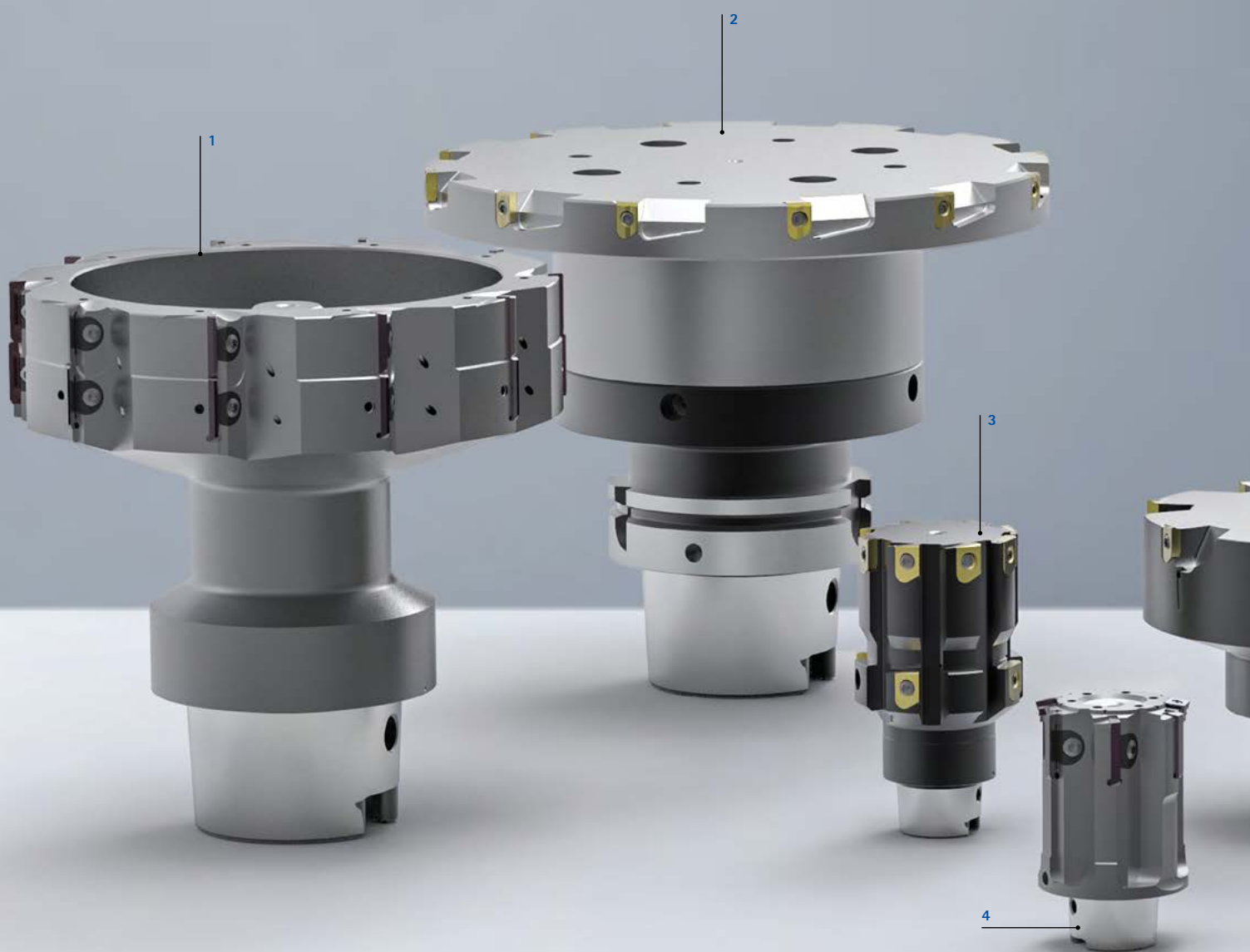



Soluzioni speciali HPR300 e HPR400

- 1 Strumento personalizzato HPR300 a due gradini, per la lavorazione del foro per cuscinetti nella scatola del cambio
- 2 HPR400 con taglienti rivestiti in CVD con diametro 160 mm, per la lavorazione della scatola del differenziale con innesto modulare orientabile
- 3 Utensile HPR400 a due gradini con otto taglienti per il foro del pistone e con quattro taglienti per il taglio di controllo della pinza del freno
- 4 Utensile combinato con taglienti tangenziali ISO per la lavorazione preliminare e HPR300 con taglienti con riporto in PCD per la finitura di una boccia in ottone
- 5 Strumento personalizzato HPR400 per il foro del ponte assiale in GJS-400 con taglienti speciali CVD per la lavorazione della sede del cuscinetto e per la rettifica a tuffo assiale
- 6 Utensile combinato in struttura leggera con innesto modulare orientabile su adattatore HSK per la lavorazione dell'involucro di un pignone conico. Con taglienti tangenziali ISO per la lavorazione preliminare e sistema HPR400 per la finitura
- 7 HPR300 lavorazione dello smusso
- 8 Utensile combinato con punta in metallo duro integrale come soluzione a innesto e gradino di alesatura HPR400 per la lavorazione di un cuscinetto a snodo
- 9 Utensile a gradini HPR400 in struttura leggera con innesto modulare orientabile, per la lavorazione dell'involucro di un azionamento a pignone conico



SVASATURA

Svasatura con utensili a passo estremamente differenziato.
Silenziosi, veloci e precisi per una svasatura ottimale.



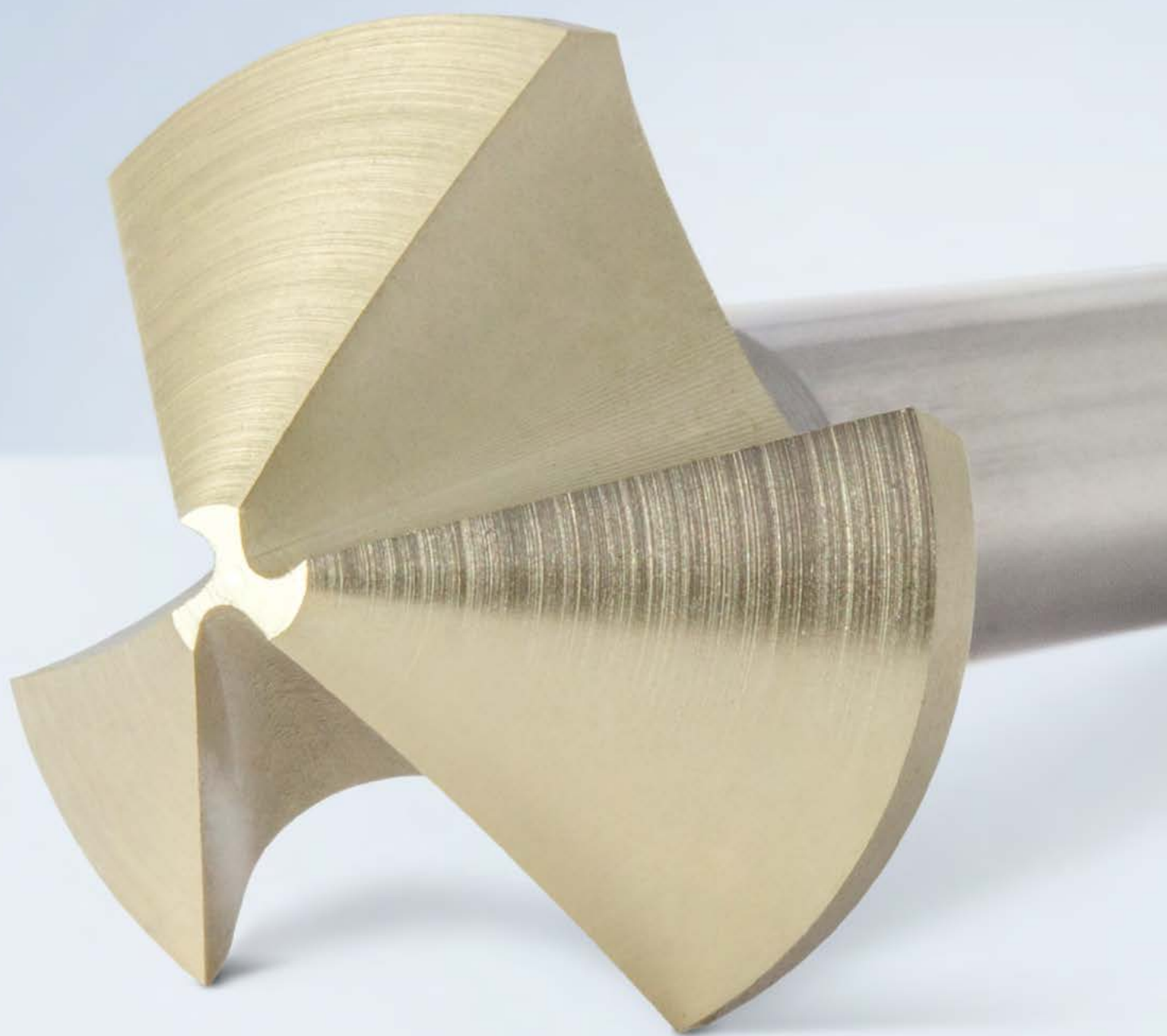

UTENSILI DI SVA- SATURA A PASSO ESTREMAMENTE DIFFERENZIATO

Introduzione

Tecnologia 586

Utensili di svasatura

Variante HSS rivestita 588

Variante in metallo duro integrale rivestita 589

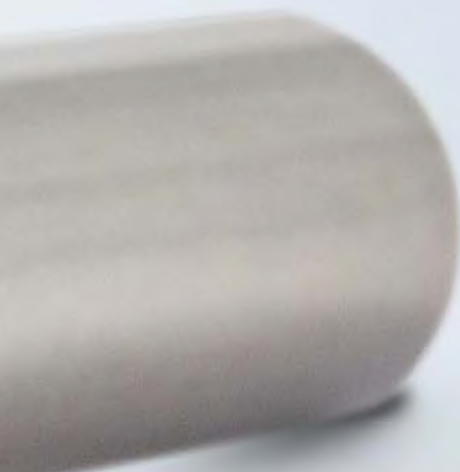



UTENSILI DI SVASATURA A PASSO ESTREMAMENTE DIFFERENZIATO

Per una lavorazione silenziosa, veloce e precisa

Esiste un potenziale di aumento della produttività in ogni processo di lavorazione. Anche le lavorazioni apparentemente secondarie offrono un notevole potenziale di miglioramento. E gli utensili di svasatura MAPAL ne sono la prova.

Gli utensili di svasatura funzionano con forze assiali notevolmente ridotte. I taglienti presentano un passo differenziato. Con questo rapporto, la forza assiale viene ridotta di oltre il 50% e la forza radiale del 25% rispetto agli utensili tradizionali. Tali condizioni di impiego

ottimizzate permettono una notevole riduzione delle vibrazioni sull'utensile, consentendo una maggiore precisione e migliori valori di superficie. La precisione di svasatura garantisce una realizzazione sensibilmente migliore dei collegamenti a vite e a rivetto, pertanto non vi è alcun assestamento del collegamento allo stato assemblato sotto carico. Il carico ridotto della macchina aumenta inoltre la durata degli utensili. Grazie al loro funzionamento silenzioso e stabile, gli utensili possono anche essere impiegati con parametri di lavorazione superiori. Ne consegue un notevole risparmio di tempo.



Caratteristiche utensile nel dettaglio

Forza radiale ridotta del 25%

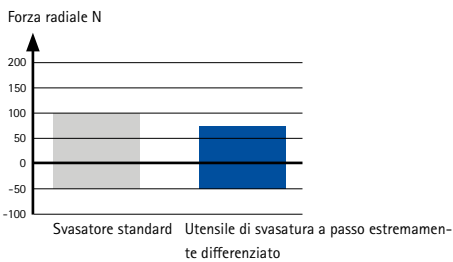

Forza assiale ridotta del 50%

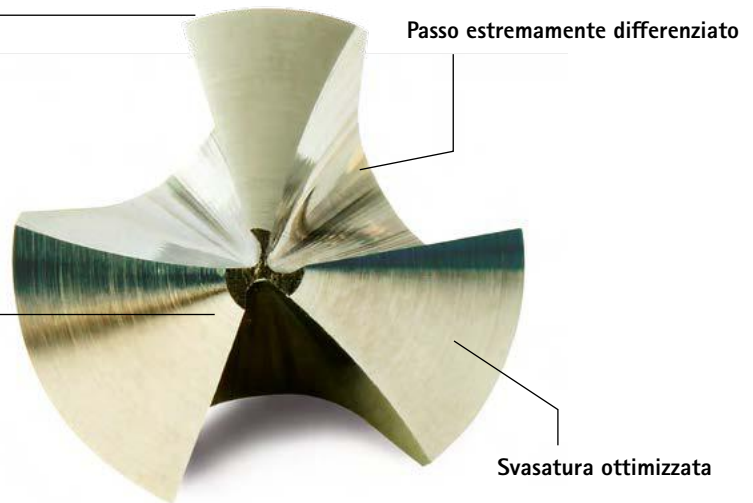
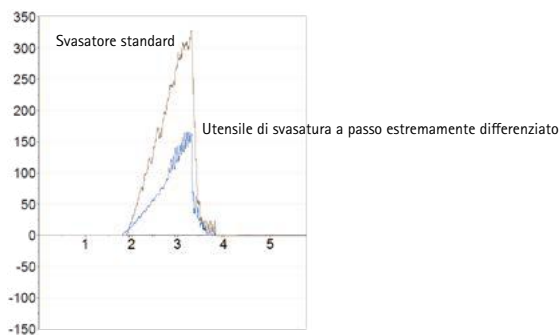

Utensile di svasatura a passo estremamente differenziato



Svasatore standard

Versione in HSS rivestita



Per tutti i materiali più diffusi come acciaio, acciaio inossidabile o alluminio, gli utensili di svasatura in versione HSS con rivestimento ad alte prestazioni sono la scelta ideale. Il rivestimento assicura lunga durata. Gli utensili lavorano in maniera affidabile e sicura anche ad elevate velocità di taglio. In caso di materiali più impegnativi, si raccomanda l'uso della versione in metallo duro integrale.

Versione in metallo duro integrale rivestita



Oltre alle versioni di utensili di svasatura in HSS con rivestimento ad alte prestazioni, MAPAL offre diametri selezionati anche nella versione in metallo duro integrale rivestito. Accanto ai vantaggi derivanti dal passo differenziato, la versione in metallo duro integrale offre ulteriori benefici soprattutto nella lavorazione di materiali impegnativi come il titanio, la ghisa altamente legata, Inconel o CFRP. Rispetto alla versione in HSS rivestita, è possibile ottenere durate e velocità di taglio superiori nella totale sicurezza dei processi.

Versioni speciali delle punte con gradino di svasatura



MAPAL offre la possibilità di realizzare una soluzione speciale con gradino di svasatura per pressoché tutte le punte in metallo duro integrale. Ciò permette di eseguire le due lavorazioni di foratura e svasatura con un solo utensile e di ridurre così i tempi non produttivi. Le modernissime tecnologie e la produzione flessibile di MAPAL consentono tempi di consegna brevi per soluzioni speciali in tutto il mondo.

Utensile di svasatura a 90°

Versione in HSS rivestita, passo estremamente differenziato
COS110

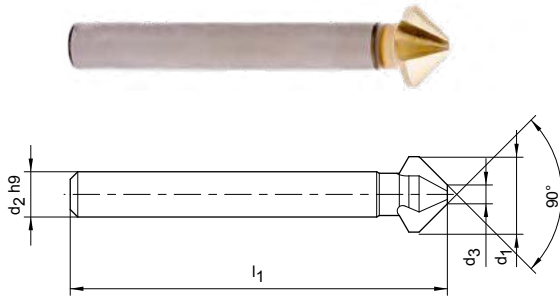

Dimensioni					Specifiche	Codice
d ₁	d ₂	d ₃	l ₁	z		
4,30	4	1,3	40	3	COS110-0430-335C-SP345	30662991
6,00	5	1,5	45	3	COS110-0600-335C-SP345	30662992
6,30	5	1,5	45	3	COS110-0630-335C-SP345	30633783
8,00	6	2,0	50	3	COS110-0800-335C-SP345	30662993
8,30	6	2,0	50	3	COS110-0830-335C-SP345	30662994
10,00	6	2,5	50	3	COS110-1000-335C-SP345	30662996
10,40	6	2,5	50	3	COS110-1040-335C-SP345	30633784
11,50	8	2,8	56	3	COS110-1150-335C-SP345	30662997
12,40	8	2,8	56	3	COS110-1240-335C-SP345	30662998
15,00	10	3,2	60	3	COS110-1500-335C-SP345	30662999
16,50	10	3,2	60	3	COS110-1650-335C-SP345	30633786
19,00	10	3,5	63	3	COS110-1900-335C-SP345	30663000
20,50	10	3,5	63	3	COS110-2050-335C-SP345	30633787
23,00	10	3,8	67	3	COS110-2300-335C-SP345	30663001
25,00	10	3,8	67	3	COS110-2500-335C-SP345	30633788
31,00	12	4,2	71	3	COS110-3100-335C-SP345	30663003



Set di svasatori conici

d ₁	Specifiche	Codice
6,30 - 25,00	COS110-6.3-25-335C-SP345-SET Set composto da ø 6,30 mm ø 10,4 mm ø 16,5 mm ø 20,5 mm ø 25,0 mm	30634356

Misure in mm.

Per i parametri di lavorazione consigliati, vedere la fine del capitolo.

Utensile di svasatura a 90°

Versione in metallo duro integrale rivestita, passo estremamente differenziato
COS110

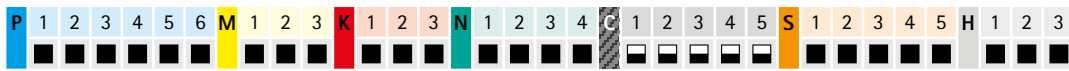
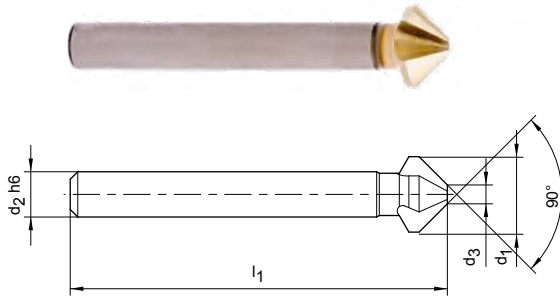

Dimensioni					Specifiche	Codice
d_1	d_2	d_3	l_1	z		
6,30	5	1,5	45	3	COS110-0630-335C-HP437	30799189
8,30	6	2,0	50	3	COS110-0830-335C-HP437	30799191
10,40	6	2,5	50	3	COS110-1040-335C-HP437	30799192
12,40	8	2,8	56	3	COS110-1240-335C-HP437	30799195
16,50	10	3,2	60	3	COS110-1650-335C-HP437	30799198
20,50	10	3,5	63	3	COS110-2050-335C-HP437	30799199
25,00	10	3,8	67	3	COS110-2500-335C-HP437	30799201
31,00	12	4,2	71	3	COS110-3100-335C-HP437	30799203

Misure in mm.

Per i parametri di lavorazione consigliati, vedere la fine del capitolo.

Parametri di lavorazione consigliati per utensili di svasatura

Utensili di svasatura a passo estremamente differenziato, versione in HSS rivestito
Avanzamento e velocità di taglio

GTM*		Materiale	Resistenza/durezza [N/mm ²] [HRC]	
P	P1	P1.1 Acciai da costruzione, automatici, da cementazione e da bonifica, non legati	< 700	
		P1.2 Acciai da costruzione, automatici, da cementazione e da bonifica, non legati	< 1.200	
	P2	P2.1 Acciai da niturazione, da cementazione e da bonifica, legati	< 900	
		P2.2 Acciai da niturazione, da cementazione e da bonifica, legati	< 1.400	
	P3	P3.1 Acciai per utensili, per cuscinetti volventi, armonici e per lavorazioni veloci**	< 800	
		P3.2 Acciai per utensili, per cuscinetti volventi, armonici e per lavorazioni veloci**	< 1.000	
		P3.3 Acciai per utensili, per cuscinetti volventi, armonici e per lavorazioni veloci**	< 1.500	
	P4	P4.1 Acciai inossidabili, ferritici e martensitici		
	P5	P5.1 Acciaio fuso		
	P6	P6.1 Acciaio fuso, ferritico e martensitico		
M	M1	M1.1 Acciai inossidabili, austenitici	< 700	
		M1.2 Acciai inossidabili, ferritici/austenitici (Duplex)	< 1.000	
	M2	M2.1 Acciaio fuso inossidabile, austenitico	< 700	
	M3	M3.1 Acciaio fuso inossidabile, ferritico/austenitico (Duplex)	< 1.000	
K	K1	K1.1 Ghisa con grafite lamellare (ghisa grigia), GJL	< 300	
		K2.1 Ghisa con grafite sferoidale, GJS	< 500	
		K2.2 Ghisa con grafite sferoidale, GJS	≤ 800	
	K2	K2.3 Ghisa con grafite sferoidale, GJS	> 800	
		K3	K3.1 Ghisa con grafite vermicolare, GJV; acciaio fuso malleabile, GJM	< 500
			K3.2 Ghisa con grafite vermicolare, GJV; acciaio fuso malleabile, GJM	> 500
N	N1	N1.1 Alluminio, non legato e legato < 3% Si		
		N1.2 Alluminio, legato ≤ 7% Si		
		N1.3 Alluminio, legato > 7-12% Si		
		N1.4 Alluminio, legato > 12% Si		
	N2	N2.1 Rame, non legato e bassolegato	< 300	
		N2.2 Rame, legato	> 300	
		N2.3 Ottone, bronzo, ghisa rossa	< 1.200	
	N4	N4.1 Plastica, thermoplast		
		N4.2 Plastica, duroplast		
		N4.3 Plastica, materiali espansi		
S	S1	S1.1 Titanio, leghe di titanio	< 400	
		S2.1 Titanio, leghe di titanio	< 1.200	
	S2	S2.2 Titanio, leghe di titanio	> 1.200	
		S3	S3.1 Nichel, non legato e legato	< 900
	S3.2 Nichel, non legato e legato		> 900	
	S4	S4.1 Superlega resistente ad alte temperature a base di Ni, Co e Fe		
	S5	S5.1 Leghe di tungsteno e molibdeno		
H	H1	H1.1 Acciaio temprato/acciaio fuso	< 44	
		H1.2 Acciaio temprato/acciaio fuso	< 55	

* Gruppi di materiale MAPAL

** Qualora la somma dei componenti di lega Cr, Mo, Ni, V, W equivalesse a > 8%, selezionare il gruppo di materiale MAPAL immediatamente superiore.

Pagina seguente:
Versione in metallo duro integrale

	ø < 5 [mm]		ø < 5 - 8 [mm]		ø < 8 - 12 [mm]		ø < 12 - 16 [mm]		ø < 16 - 20 [mm]		ø < 20 - 25 [mm]		ø < 25 - 31 [mm]	
	v _c [m/min]	f [mm]	v _c [m/min]	f [mm]	v _c [m/min]	f [mm]	v _c [m/min]	f [mm]	v _c [m/min]	f [mm]	v _c [m/min]	f [mm]	v _c [m/min]	f [mm]
	40	0,06	40	0,08	40	0,10	40	0,12	40	0,14	40	0,18	40	0,22
	30	0,04	30	0,06	30	0,08	30	0,10	30	0,12	30	0,14	30	0,18
	30	0,04	30	0,06	30	0,08	30	0,10	30	0,12	30	0,14	30	0,18
	12	0,03	12	0,04	12	0,05	12	0,06	12	0,08	12	0,10	12	0,12
	30	0,04	30	0,06	30	0,08	30	0,10	30	0,12	30	0,14	30	0,18
	12	0,03	12	0,04	12	0,05	12	0,06	12	0,08	12	0,10	12	0,12
	15	0,04	15	0,05	15	0,06	15	0,07	15	0,08	15	0,09	15	0,12
	30	0,04	30	0,06	30	0,08	30	0,10	30	0,12	30	0,14	30	0,18
	15	0,04	15	0,05	15	0,06	15	0,07	15	0,08	15	0,09	15	0,12
	15	0,04	15	0,05	15	0,06	15	0,07	15	0,08	15	0,09	15	0,12
	10	0,04	10	0,05	10	0,06	10	0,07	10	0,08	10	0,09	10	0,12
	15	0,04	15	0,05	15	0,06	15	0,07	15	0,08	15	0,09	15	0,12
	20	0,06	20	0,10	20	0,12	20	0,14	20	0,18	20	0,20	20	0,25
	20	0,06	20	0,10	20	0,12	20	0,14	20	0,18	20	0,20	20	0,25
	20	0,06	20	0,10	20	0,12	20	0,14	20	0,18	20	0,20	20	0,25
	20	0,06	20	0,10	20	0,12	20	0,14	20	0,18	20	0,20	20	0,25
	20	0,06	20	0,10	20	0,12	20	0,14	20	0,18	20	0,20	20	0,25
	20	0,06	20	0,10	20	0,12	20	0,14	20	0,18	20	0,20	20	0,25
	50	0,08	50	0,10	50	0,12	50	0,14	50	0,18	50	0,22	50	0,26
	50	0,08	50	0,10	50	0,12	50	0,14	50	0,18	50	0,22	50	0,26
	40	0,08	40	0,10	40	0,12	40	0,14	40	0,18	40	0,22	40	0,26
	40	0,08	40	0,10	40	0,12	40	0,14	40	0,18	40	0,22	40	0,26
	40	0,10	40	0,12	40	0,14	40	0,18	40	0,20	40	0,24	40	0,30
	40	0,10	40	0,12	40	0,14	40	0,18	40	0,20	40	0,24	40	0,30
	40	0,10	40	0,12	40	0,14	40	0,18	40	0,20	40	0,24	40	0,30
	40	0,10	40	0,12	40	0,14	40	0,18	40	0,20	40	0,24	40	0,30
	40	0,10	40	0,12	40	0,14	40	0,18	40	0,20	40	0,24	40	0,30
	10	0,04	10	0,05	10	0,06	10	0,07	10	0,08	10	0,09	10	0,12
	10	0,04	10	0,05	10	0,06	10	0,07	10	0,08	10	0,09	10	0,12
	10	0,04	10	0,05	10	0,06	10	0,07	10	0,08	10	0,09	10	0,12
	10	0,04	10	0,05	10	0,06	10	0,07	10	0,08	10	0,09	10	0,12
	10	0,04	10	0,05	10	0,06	10	0,07	10	0,08	10	0,09	10	0,12
	10	0,04	10	0,05	10	0,06	10	0,07	10	0,08	10	0,09	10	0,12
	10	0,04	10	0,05	10	0,06	10	0,07	10	0,08	10	0,09	10	0,12
	6	0,04	6	0,05	6	0,06	6	0,08	6	0,08	6	0,10		
	6	0,04	6	0,05	6	0,06	6	0,08	6	0,08	6	0,10		

I parametri di lavorazione indicati sono valori orientativi.

I dati ottimali per la specifica applicazione devono essere rilevati eseguendo diversi tentativi o durante l'effettiva lavorazione.

Parametri di lavorazione consigliati per utensili di svasatura

Utensili di svasatura a passo estremamente differenziato, versione in metallo duro integrale rivestito
Avanzamento e velocità di taglio

GTM*		Materiale	Resistenza/durezza [N/mm ²] [HRC]
P	P1	P1.1 Acciai da costruzione, automatici, da cementazione e da bonifica, non legati	< 700
		P1.2 Acciai da costruzione, automatici, da cementazione e da bonifica, non legati	< 1.200
	P2	P2.1 Acciai da nitrazione, da cementazione e da bonifica, legati	< 900
		P2.2 Acciai da nitrazione, da cementazione e da bonifica, legati	< 1.400
	P3	P3.1 Acciai per utensili, per cuscinetti volventi, armonici e per lavorazioni veloci**	< 800
		P3.2 Acciai per utensili, per cuscinetti volventi, armonici e per lavorazioni veloci**	< 1.000
P3.3 Acciai per utensili, per cuscinetti volventi, armonici e per lavorazioni veloci**		< 1.500	
P4	P4.1 Acciai inossidabili, ferritici e martensitici		
P5	P5.1 Acciaio fuso		
P6	P6.1 Acciaio fuso, ferritico e martensitico		
M	M1	M1.1 Acciai inossidabili, austenitici	< 700
		M1.2 Acciai inossidabili, ferritici/austenitici (Duplex)	< 1000
	M2	M2.1 Acciaio fuso inossidabile, austenitico	< 700
	M3	M3.1 Acciaio fuso inossidabile, ferritico/austenitico (Duplex)	< 1.000
K	K1	K1.1 Ghisa con grafite lamellare (ghisa grigia), GJL	< 300
		K2.1 Ghisa con grafite sferoidale, GJS	< 500
	K2	K2.2 Ghisa con grafite sferoidale, GJS	≤ 800
		K2.3 Ghisa con grafite sferoidale, GJS	> 800
	K3	K3.1 Ghisa con grafite vermicolare, GJV; acciaio fuso malleabile, GJM	< 500
		K3.2 Ghisa con grafite vermicolare, GJV; acciaio fuso malleabile, GJM	> 500
N	N1	N1.1 Alluminio, non legato e legato < 3% Si	
		N1.2 Alluminio, legato ≤ 7% Si	
		N1.3 Alluminio, legato > 7-12% Si	
		N1.4 Alluminio, legato > 12% Si	
	N2	N2.1 Rame, non legato e bassolegato	< 300
		N2.2 Rame, legato	> 300
		N2.3 Ottone, bronzo, ghisa rossa	< 1.200
	N3	N3.1 Grafite > 8 µm	
		N3.2 Grafite < 8 µm	
	N4	N4.1 Plastica, thermoplast	
		N4.2 Plastica, duroplast	
		N4.3 Plastica, materiali espansi	
C	C1	C1.1 Matrice plastica, rinforzata con fibre di aramide (AFK)	
		C1.2 Matrice plastica (duroplastica), CFK/GFK	
		C1.3 Matrice plastica (termoplastica), CFK/GFK	
	C2	C2.1 Matrice in carbonio, rinforzata con fibre di carbonio (CFC)	
		C3.1 Matrice metallica (MMC)	
	C4	C4.1 Struttura a sandwich, nucleo a nido d'ape (Honeycomb)	
		C4.2 Struttura a sandwich, nucleo in materiale espanso	
	C5	C5.1 Composito stratificato (stack), composito non metallico/non ferroso	
		C5.2 Composito stratificato (stack), composito non metallico/metallico	
		C5.3 Composito stratificato (stack), composito non metallico/non metallico	
		C5.4 Composito stratificato (stack), composito non ferroso/non ferroso	
		C5.5 Composito stratificato (stack), composito non ferroso/metallico	
C5.6 Composito stratificato (stack), composito metallico/metallico			
S	S1	S1.1 Titanio, leghe di titanio	< 400
		S2.1 Titanio, leghe di titanio	< 1.200
	S2	S2.2 Titanio, leghe di titanio	> 1.200
		S3.1 Nichel, non legato e legato	< 900
	S3	S3.2 Nichel, non legato e legato	> 900
		S4.1 Superlega resistente ad alte temperature a base di Ni, Co e Fe	
S5	S5.1 Leghe di tungsteno e molibdeno		
H	H1	H1.1 Acciaio temprato/acciaio fuso	< 44
		H1.2 Acciaio temprato/acciaio fuso	< 55
	H2	H2.1 Acciaio temprato/acciaio fuso	< 60
		H2.2 Acciaio temprato/acciaio fuso	< 65
	H3	H2.3 Acciaio temprato/acciaio fuso	< 68
		H3.1 Ghisa resistente all'usura/ghisa temperata, GJN	

* Gruppi di materiale MAPAL

** Qualora la somma dei componenti di lega Cr, Mo, Ni, V, W equivalesse a > 8%, selezionare il gruppo di materiale MAPAL immediatamente superiore.

	ø < 5 [mm]		ø < 5 - 8 [mm]		ø < 8 - 12 [mm]		ø < 12 - 16 [mm]		ø < 16 - 20 [mm]		ø < 20 - 25 [mm]		ø < 25 - 31 [mm]	
	v _c [m/min]	f [mm]	v _c [m/min]	f [mm]	v _c [m/min]	f [mm]	v _c [m/min]	f [mm]	v _c [m/min]	f [mm]	v _c [m/min]	f [mm]	v _c [m/min]	f [mm]
	60	0,06	60	0,08	60	0,10	60	0,12	60	0,14	60	0,18	60	0,22
	50	0,04	50	0,06	50	0,08	50	0,10	50	0,12	50	0,14	50	0,18
	50	0,04	50	0,06	50	0,08	50	0,10	50	0,12	50	0,14	50	0,18
	40	0,03	40	0,04	40	0,05	40	0,06	40	0,08	40	0,10	40	0,12
	50	0,04	50	0,06	50	0,08	50	0,10	50	0,12	50	0,14	50	0,18
	40	0,03	40	0,04	40	0,05	40	0,06	40	0,08	40	0,10	40	0,12
	30	0,04	30	0,05	30	0,06	30	0,07	30	0,08	30	0,09	30	0,12
	50	0,04	50	0,06	50	0,08	50	0,10	50	0,12	50	0,14	50	0,18
	30	0,04	30	0,05	30	0,06	30	0,07	30	0,08	30	0,09	30	0,12
	30	0,04	30	0,05	30	0,06	30	0,07	30	0,08	30	0,09	30	0,12
	25	0,04	25	0,05	25	0,06	25	0,07	25	0,08	25	0,09	25	0,12
	30	0,04	30	0,05	30	0,06	30	0,07	30	0,08	30	0,09	30	0,12
	25	0,04	25	0,05	25	0,06	25	0,07	25	0,08	25	0,09	25	0,12
	50	0,06	50	0,10	50	0,12	50	0,14	50	0,18	50	0,20	50	0,25
	45	0,06	45	0,10	45	0,12	45	0,14	45	0,18	45	0,20	45	0,25
	45	0,06	45	0,10	45	0,12	45	0,14	45	0,18	45	0,20	45	0,25
	45	0,06	45	0,10	45	0,12	45	0,14	45	0,18	45	0,20	45	0,25
	35	0,06	35	0,10	35	0,12	35	0,14	35	0,18	35	0,20	35	0,25
	35	0,06	35	0,10	35	0,12	35	0,14	35	0,18	35	0,20	35	0,25
	80	0,08	80	0,10	80	0,12	80	0,14	80	0,18	80	0,22	80	0,26
	80	0,08	80	0,10	80	0,12	80	0,14	80	0,18	80	0,22	80	0,26
	60	0,08	60	0,10	60	0,12	60	0,14	60	0,18	60	0,22	60	0,26
	60	0,08	60	0,10	60	0,12	60	0,14	60	0,18	60	0,22	60	0,26
	70	0,10	70	0,12	70	0,14	70	0,18	70	0,20	70	0,24	70	0,30
	70	0,10	70	0,12	70	0,14	70	0,18	70	0,20	70	0,24	70	0,30
	70	0,10	70	0,12	70	0,14	70	0,18	70	0,20	70	0,24	70	0,30
	25	0,06	25	0,10	25	0,12	25	0,14	25	0,18	25	0,20	25	0,25
	25	0,06	25	0,10	25	0,12	25	0,14	25	0,18	25	0,20	25	0,25
	70	0,10	70	0,12	70	0,14	70	0,18	70	0,20	70	0,24	70	0,30
	70	0,10	70	0,12	70	0,14	70	0,18	70	0,20	70	0,24	70	0,30
	70	0,10	70	0,12	70	0,14	70	0,18	70	0,20	70	0,24	70	0,30
	25	0,06	25	0,10	25	0,12	25	0,14	25	0,18	25	0,20	25	0,25
	25	0,06	25	0,10	25	0,12	25	0,14	25	0,18	25	0,20	25	0,25
	25	0,06	25	0,10	25	0,12	25	0,14	25	0,18	25	0,20	25	0,25
	25	0,06	25	0,10	25	0,12	25	0,14	25	0,18	25	0,20	25	0,25
	25	0,06	25	0,10	25	0,12	25	0,14	25	0,18	25	0,20	25	0,25
	25	0,06	25	0,10	25	0,12	25	0,14	25	0,18	25	0,20	25	0,25
	25	0,06	25	0,10	25	0,12	25	0,14	25	0,18	25	0,20	25	0,25
	25	0,06	25	0,10	25	0,12	25	0,14	25	0,18	25	0,20	25	0,25
	25	0,06	25	0,10	25	0,12	25	0,14	25	0,18	25	0,20	25	0,25
	25	0,06	25	0,10	25	0,12	25	0,14	25	0,18	25	0,20	25	0,25
	25	0,06	25	0,10	25	0,12	25	0,14	25	0,18	25	0,20	25	0,25
	15	0,04	15	0,05	15	0,06	15	0,07	15	0,08	15	0,09	15	0,12
	15	0,04	15	0,05	15	0,06	15	0,07	15	0,08	15	0,09	15	0,12
	15	0,04	15	0,05	15	0,06	15	0,07	15	0,08	15	0,09	15	0,12
	15	0,04	15	0,05	15	0,06	15	0,07	15	0,08	15	0,09	15	0,12
	15	0,04	15	0,05	15	0,06	15	0,07	15	0,08	15	0,09	15	0,12
	15	0,04	15	0,05	15	0,06	15	0,07	15	0,08	15	0,09	15	0,12
	12	0,04	12	0,05	12	0,06	12	0,08	12	0,08	12	0,10		
	12	0,04	12	0,05	12	0,06	12	0,08	12	0,08	12	0,10		
	8	0,04	8	0,05	8	0,06	8	0,08	8	0,08	8	0,10		
	8	0,04	8	0,05	8	0,06	8	0,08	8	0,08	8	0,10		
	12	0,04	12	0,05	12	0,06	12	0,08	12	0,08	12	0,10		

I parametri di lavorazione indicati sono valori orientativi.

I dati ottimali per la specifica applicazione devono essere rilevati eseguendo diversi tentativi o durante l'effettiva lavorazione.

BARENATURA E TORNITURA

Le cartucce assicurano massima flessibilità per soluzioni altamente personalizzate. Gamma ModulBore come soluzione modulare per barenatura e lavorazioni di precisione.

Inserti a fissaggio meccanico positivi radiali per barenatura e tornitura. Inserti a fissaggio tangenziale per requisiti di lavorazione estremamente elevati.



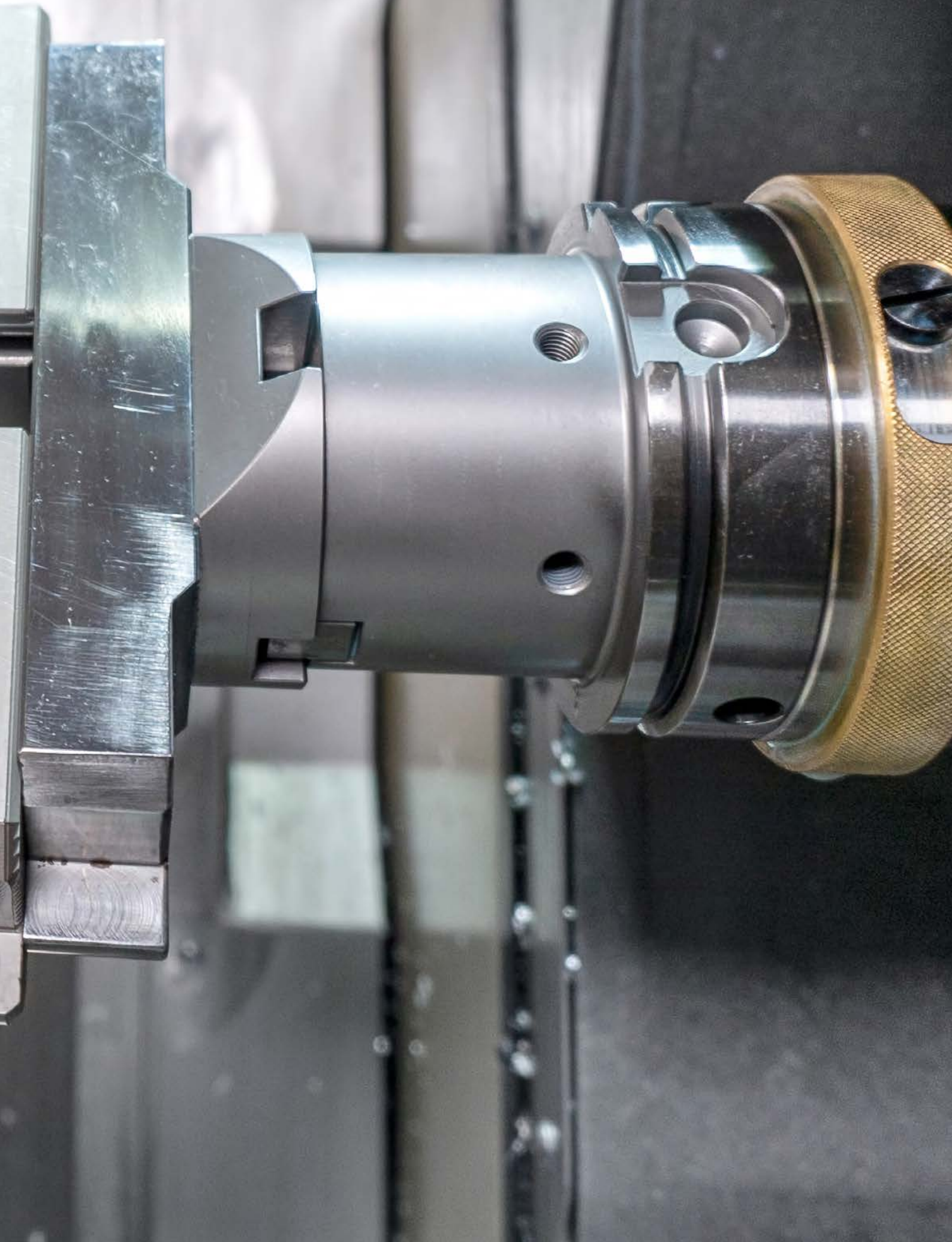

PANORAMICA PRODOTTI

Barenatura e tornitura

Gli utensili di barenatura MAPAL che intervengono in quella fase di lavorazione che sta tra la foratura dal pieno e la finitura combinano in maniera eccellente le migliori caratteristiche di robustezza, per assorbire le forze di lavorazione in gioco, e alta redditività. Grazie a tecnologie innovative e una precisione assoluta, MAPAL è in grado di offrire un vasto assortimento di strumenti personalizzati dotati di inserti a fissaggio meccanico e taglienti in PCD fissi brasati. L'approfondita conoscenza dell'intero processo di materiale e del ciclo produttivo nel suo insieme consente di realizzare progressi concreti.

La gamma standard ModulBore di MAPAL assicura un sistema completo per la lavorazione

preliminare e di finitura di fori in un range di diametro da 6 a 1.000 mm. Le cartucce consentono una facile regolazione e offrono numerose possibilità in svariate applicazioni. L'assortimento standard è compatibile con tutti gli inserti a fissaggio meccanico ISO in commercio e copre la maggior parte delle varianti costruttive.

L'offerta di inserti in versione speciale, di tipo radiale e tangenziale, è in grado di soddisfare le più disparate esigenze in termini di materiali da taglio e rivestimenti, oltre che adattarsi alle diverse geometrie del tagliente e range di precisione richiesti. Sono infine disponibili anche inserti selezionati in metallo duro con riporto in PCD per applicazioni di tornitura.



Soluzioni speciali



Barenatura con PCD

- Soluzioni utensili personalizzate per operazioni di lavorazione complesse
- Massima qualità di lavorazione quanto a misura, superficie e forma
- Esecuzione di speciali geometrie dei taglienti
- Utensili elicoidali per la lavorazione di componenti delicati e in situazioni di serraggio labile
- Tolleranza di produzione pari a $\leq 3 \mu\text{m}$ per diametro utensile
- La versione a più gradini è garanzia di coassialità in caso di fori a gradini
- Utensili di barenatura come utensile combinato per meno tempi morti
- Soluzione ottimizzata per l'utilizzo con lubrificazione minimale (MQL)



Barenatura con inserti a fissaggio meccanico

- La struttura a più gradini riduce la necessità di utensili e il tempo di lavorazione
- Prestazioni più elevate grazie all'utilizzo della tecnologia tangenziale
- I pattini di guida garantiscono un'elevatissima precisione di posizionamento
- Pattini di guida a molla per la lavorazione in sicurezza di grandi profondità di foratura
- Soluzioni ibride combinano diversi sistemi di utensili
- In caso di situazioni di lavorazione labili o di significative lunghezze della proiezione, il sistema antivibrante assicura una qualità di lavorazione elevata e durate utili maggiori



Inserti in versione speciale

- Realizzazione di geometrie particolari e profili complessi per pressoché tutte le applicazioni
- Taglienti di profilatura per la lavorazione di profili complessi ad alta precisione di forma
- Grazie a moderni dispositivi di produzione, gli inserti speciali MAPAL garantiscono massima precisione e grande flessibilità
- Materiali da taglio ad alte prestazioni per qualsiasi applicazione
- Sono disponibili anche inserti con riporto in PCD e PcBN



Assortimento standard



ModulBore

- Range di diametro da 6 a 1000 mm
- Elevata flessibilità grazie alla struttura modulare
- Un solo utensile consente di lavorare grandi range di diametro
- Adduzione interna del refrigerante per un'asportazione dei trucioli ottimale
- Disponibile con regolazione fine (ModulBore-Plus)
- La dentatura frontale garantisce un sistema stabile e potente
- Variante con cartucce ISO per la lavorazione di grandi diametri



Cartuccia

- Elevata flessibilità grazie alla possibilità di sostituzione semplice e rapida
- Ampia corsa di regolazione
- Compatibile con tutti gli inserti a fissaggio meccanico ISO in commercio
- Idoneo per lavorazioni sia esterne che interne
- Disponibile in diverse varianti di montaggio
- Disponibile anche come cartuccia compatta con lunghezza di montaggio ridotta

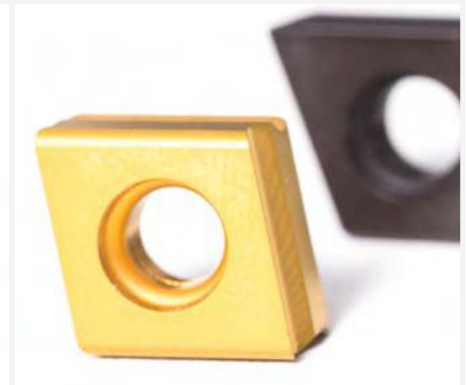

Inserti a fissaggio meccanico

- Taglienti radiali positivi per barenatura e tornitura
- Inserti a fissaggio tangenziale per requisiti estremamente elevati
- Sono disponibili taglienti levigati e pressati
- I materiali da taglio rivestiti in PVD e CVD soddisfano un'ampia gamma di requisiti, fra cui la resistenza all'usura e la tenacità
- Varianti con riporto in PCD e PcBN per una lavorazione altamente conveniente di alluminio o ghisa

SOLUZIONI SPECIALI

Barenatura con PCD

Quando si tratta di lavorare grandi quantità di componenti in alluminio e alluminio pressofuso in modo sicuro e conveniente, le soluzioni speciali con taglienti in PCD sono la scelta ideale. Grazie all'impiego di moderne unità di comando CNC e avanzata tecnologia laser, oggi è possibile realizzare in sicurezza pressoché qualsiasi geometria di tagliente, mantenendo tolleranze di produzione pari a $\leq 3 \mu\text{m}$ per diametro utensile.

La combinazione di più operazioni di lavorazione in un unico utensile risulta particolarmente efficace e conveniente. Il risparmio di utensili e la riduzione dei tempi morti improduttivi consente di incrementare la redditività della produzione.

La realizzazione di un foro a gradini, per cui è necessaria la lavorazione di più smussi e diversi raggi, viene risolta brillantemente con un utensile di barenatura in PCD a più gradini. Questo consente, inoltre, di garantire la perfetta coassialità dei singoli gradini. Anche la lavorazione di rettifiche a tuffo assiali o la svasatura piana delle superfici di appoggio possono essere eseguite in modo pratico e redditizio con un unico utensile di barenatura. Poiché non vengono generate forze radiali che agiscano sul pezzo in lavorazione, soddisfare i requisiti di planarità ed ottenere la necessaria precisione angolare risulta circa quattro volte più semplice rispetto ai tradizionali movimenti circolari o di tornitura.

MAPAL produce utensili elicoidali in PCD con vantaggi decisivi rispetto agli utensili con scanalatura dritta. Gli utensili possono essere realizzati in modo flessibile e mirato in base al processo specifico, ad esempio per la lubrificazione minimale. Le versioni HSK e i sistemi modulari orientabili garantiscono risultati ottimali.



Soluzioni speciali

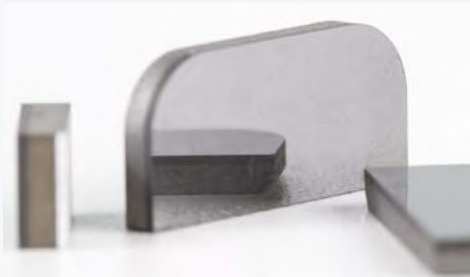

Diamante policristallino – PCD

- PCD come materiale da taglio per la lavorazione di alluminio, metalli non ferrosi, CFRP e altri materiali moderni
- Produzione sintetica a partire da particelle di diamante selezionate
- Sinterizzazione eseguita a una temperatura di circa 1.500 °C e con una pressione pari a circa 60 kbar
- Struttura estremamente dura e resistente all'usura
- Vari substrati di base consentono di scegliere sempre il materiale da taglio più idoneo all'applicazione specifica



Centro di competenza PCD

- Centro di competenza MAPAL a Pforzheim per utensili in PCD
- Sede per la progettazione e lo sviluppo di utensili in PCD leader a livello mondiale
- Elevati standard di qualità e collaboratori altamente qualificati garantiscono risultati eccellenti
- Impiego delle più moderne tecnologie di produzione
- Uso di tecnologie laser

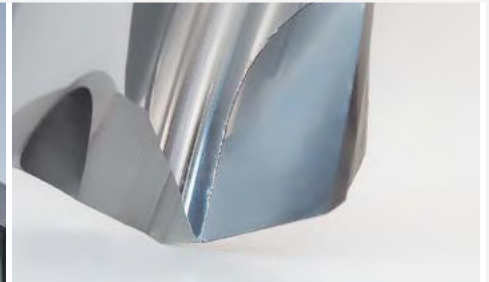

Massima precisione

- I taglienti in PCD affilati con precisione micrometrica sono sinonimo di massima precisione
- Tolleranza di produzione pari a $\leq 3 \mu\text{m}$ per diametro utensile
- Massima qualità di lavorazione quanto a misura, superficie e forma
- I gradini di convoglio dei trucioli, i rompitrucioli e i formatrucioli lavorati al laser consentono un'asportazione dei trucioli ottimale e impediscono eventuali intasamenti
- Struttura modulare per la massima precisione di concentricità
- Messa a punto precisa e sicura della concentricità grazie alla regolazione assiale e radiale

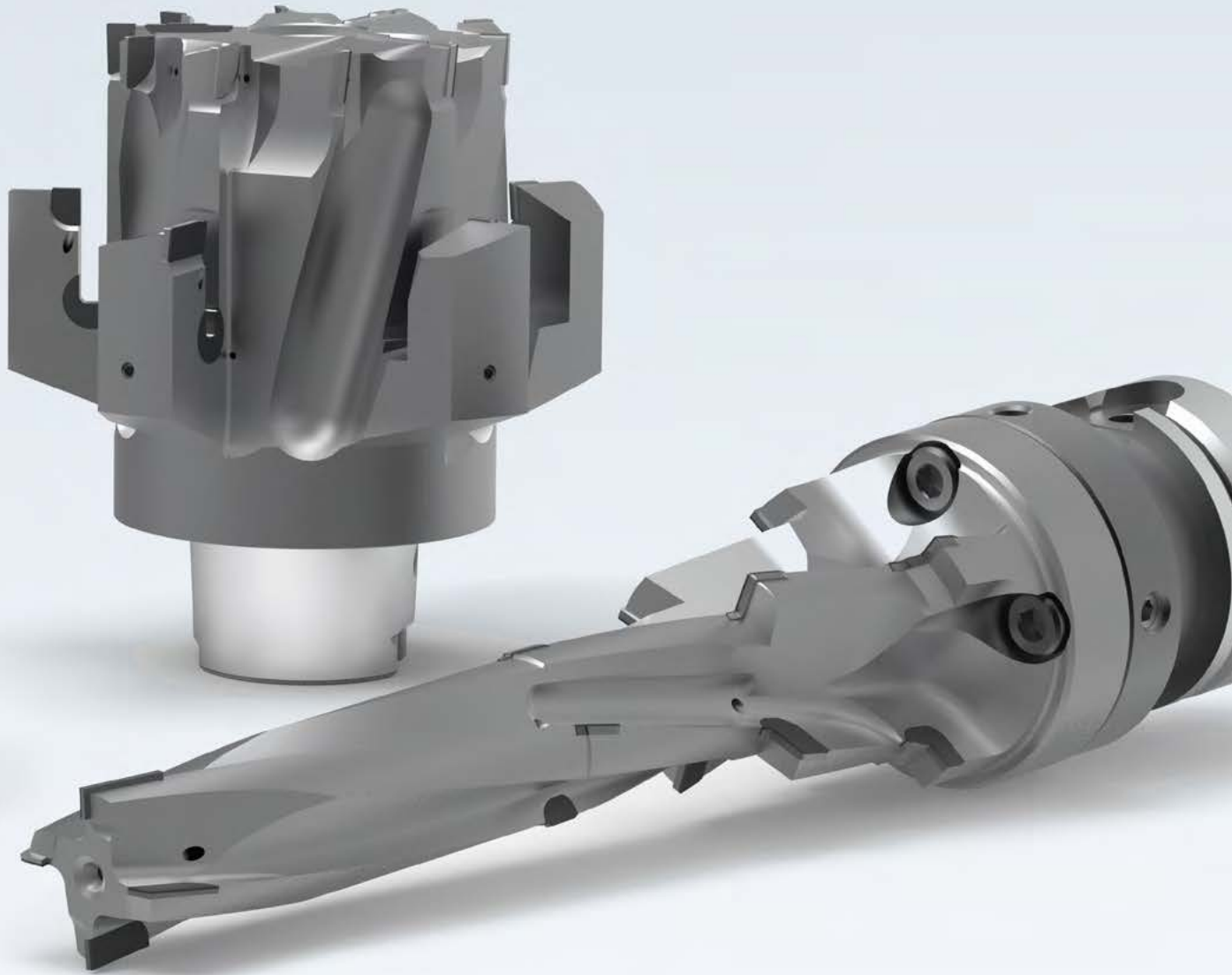

Geometrie complesse

- L'impiego della lavorazione laser consente di produrre geometrie del tagliente altamente complesse, oltre che di realizzare angoli dell'elica e di materiale estremi
- Vantaggi di un utensile di barenatura in PCD elicoidale rispetto a un utensile corrispondente con scanalature dritte:
 - Buon comportamento di guida e qualità di lavorazione molto elevate
 - Gli angoli di spoglia altamente positivi riducono le forze di taglio necessarie
 - Soluzione ideale per la lavorazione di componenti delicati e in situazioni di serraggio instabili
 - Migliore evacuazione dei trucioli grazie al disegno della scanalatura

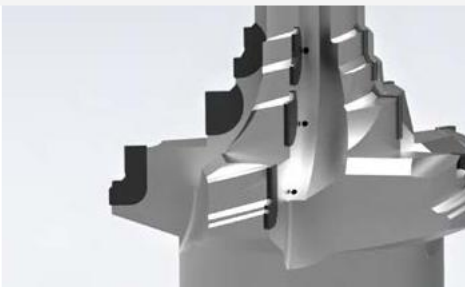

Soluzioni innovative

- Sviluppo di soluzioni per processi sicuri basate su efficienti strategie di lavorazione, come ad esempio la lubrificazione minimale (MQL)
- L'impiego di utensili combinati riduce numero di fasi del processo di lavorazione e tempi morti
- Gli utensili di barenatura in PCD a più gradini garantiscono la coassialità in caso di fori a gradini
- Taglienti in PCD integrati con precisione
- Progettazione mirata per la geometria specifica del gradino



Ricondizionamento

- Il ricondizionamento prolunga notevolmente la vita utile degli utensili di barenatura in PCD
- Risparmio sui costi di acquisto
- Utensili pronti per l'uso
- Durata utile raggiungibile senza particolari accorgimenti
- Ritiro e consegna in loco tramite corriere
- Processo standardizzato per un servizio semplice e rapido nel giro di pochi giorni

SOLUZIONI SPECIALI

Barenatura con PCD (1/2)

Esempi di applicazione di soluzioni speciali con PCD

- 1 Utensile di barenatura con inserti in PCD fissi brasati e inserti a fissaggio meccanico standard intercambiabili con opzioni di regolazione per l'esecuzione di fori IT6 e ruvidità definite
- 2 Utensile per foratura a gradini con lavorazione all'indietro regolabile e commutabile per l'asportazione truciolo di un alloggiamento del differenziale in alluminio
- 3 Utensile di barenatura combinato per la lavorazione di una pompa olio con utensile ad innesto intercambiabile in metallo duro integrale
- 4 Utensile di barenatura a più gradini per la lavorazione di una scatola/un piantone dello sterzo in AISi9Cu3. Nonostante le dimensioni estreme, grazie al corpo base in titanio il peso dell'utensile ammonta a soli 5,5 kg
- 5 Utensile di barenatura in struttura leggera per la lavorazione di una Staffa base per compattatore in AISi9Cu3. Il peso ridotto dell'utensile consente parametri di lavorazione elevati e permette di scaricare il mandrino
- 6 Utensile di barenatura a gradini elicoidale per la lavorazione di una scatola dello sterzo in AISi9Cu3 con innesto modulare orientabile. La versione elicoidale consente un taglio molto morbido e un convoglio meccanico dei trucioli
- 7 Utensile di barenatura a gradini per la lavorazione del foro per cuscinetti, con regolazione fine integrata per la punta pilota di un foro per albero a camme nella calotta della testa del cilindro in AISi9Cu3Fe per il processo con lubrificazione minimale

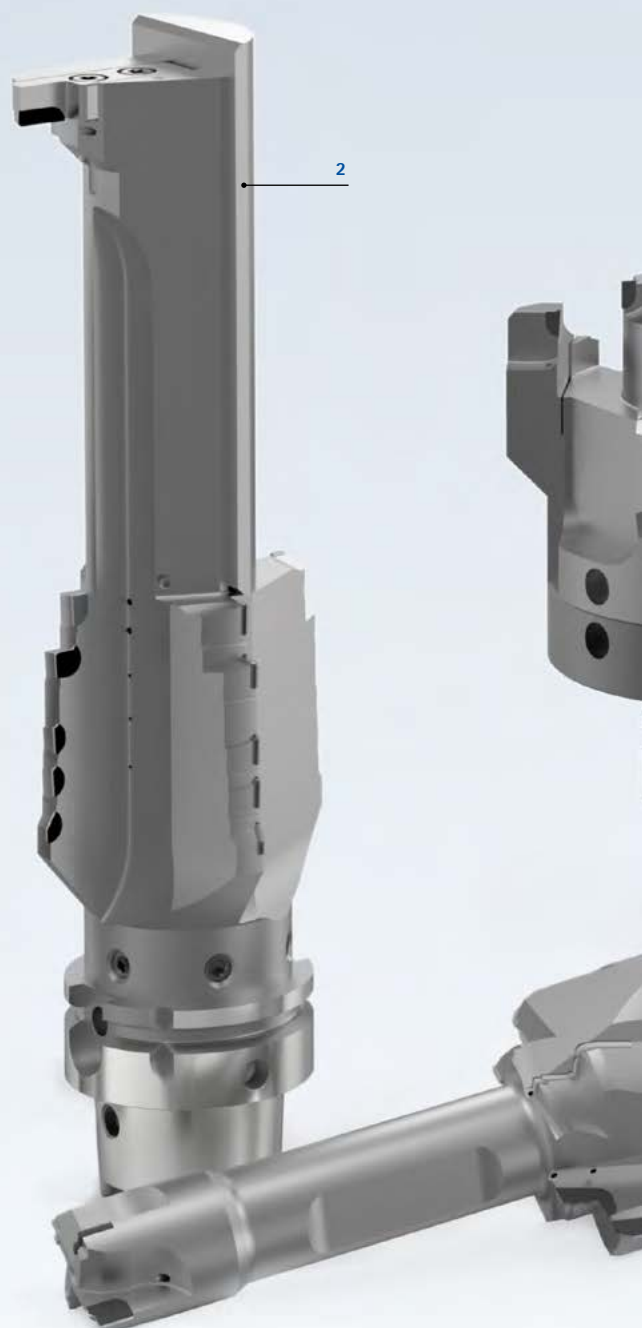

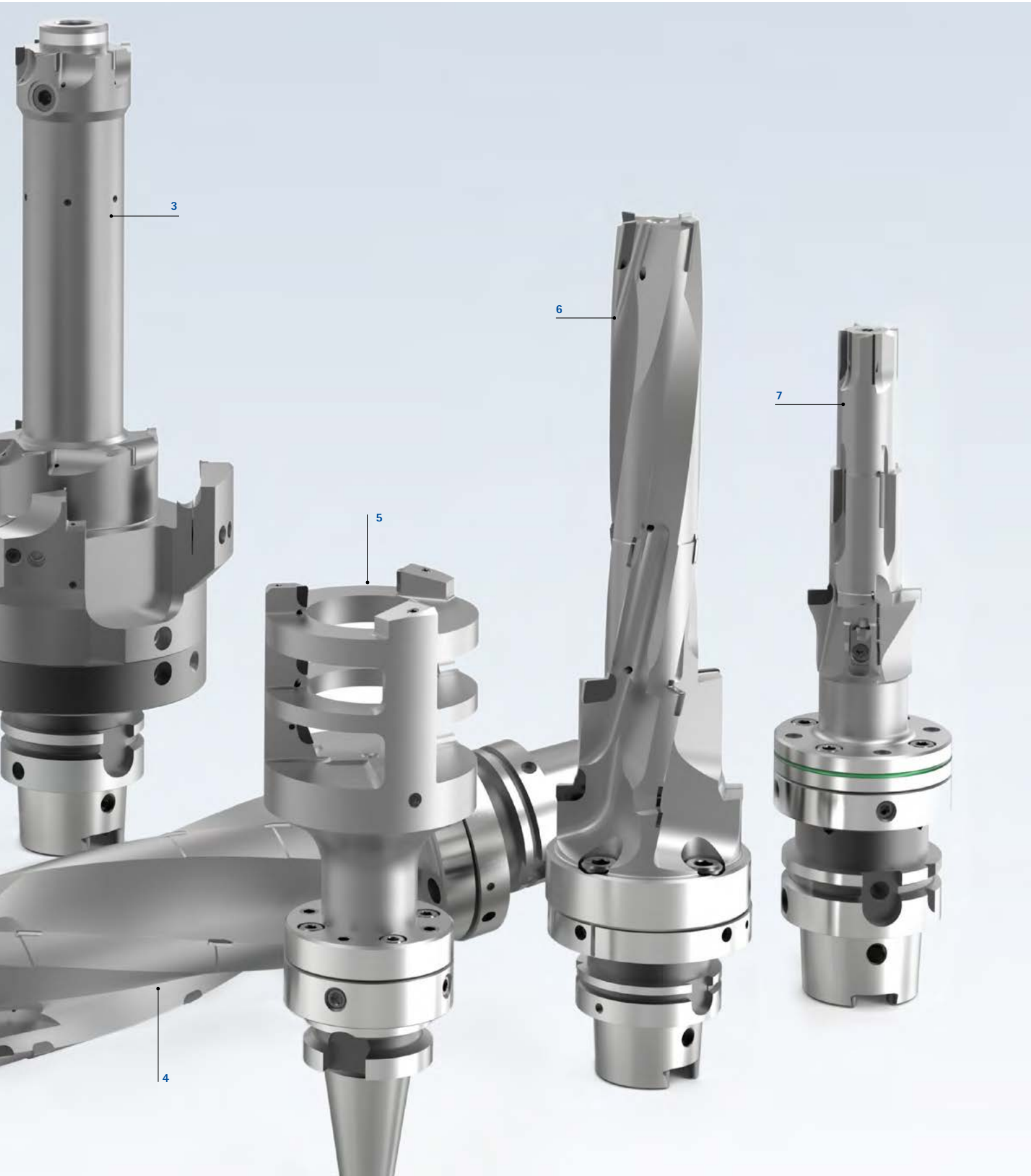

SOLUZIONI SPECIALI

Barenatura con PCD (2/2)

Esempi di applicazione di soluzioni speciali con PCD

- 1 Fresa a forare per la lavorazione di un fuso a snodo in alluminio. I taglienti integrati assicurano una lavorazione priva di vibrazioni nel pieno rispetto delle tolleranze sia di foratura che di fresatura
- 2 Utensile a campana con taglienti in PCD in struttura leggera per la lavorazione esterna di raccordi per tubi. La struttura interna a nido d'ape riduce notevolmente il peso dell'utensile utilizzando dati di taglio maggiori. Essa ha inoltre un effetto smorzante, con conseguenze positive in termini di durata
- 3 Utensile combinato per foratura e fresatura con taglienti in PCD e inserti a fissaggio meccanico in metallo duro per la lavorazione di un telaio in AISiMg0.3. I taglienti più sollecitati sono intercambiabili
- 4 Utensile elicoidale di foratura a gradini a tre taglienti per la lavorazione dei fori per le viti di un cerchione in alluminio
- 5 Soluzione di utensili con sistema antivibrante integrato per la lavorazione in una sola fase di un attuatore di ritorno dello sterzo
- 6 Fresa circolare con numero di taglienti 1+1+1 per la lavorazione di un involucro termico in AL380
- 7 Utensile di barenatura in PCD a più gradini per la lavorazione in una sola fase della scatola di un motore elettrico in AISi9Cu3Fe con struttura cava per uso su macchine utensili molto stabili e performanti
- 8 Utensile di barenatura a gradini per la lavorazione interna ed esterna di una scatola della trasmissione in AISi9Cu3Mg

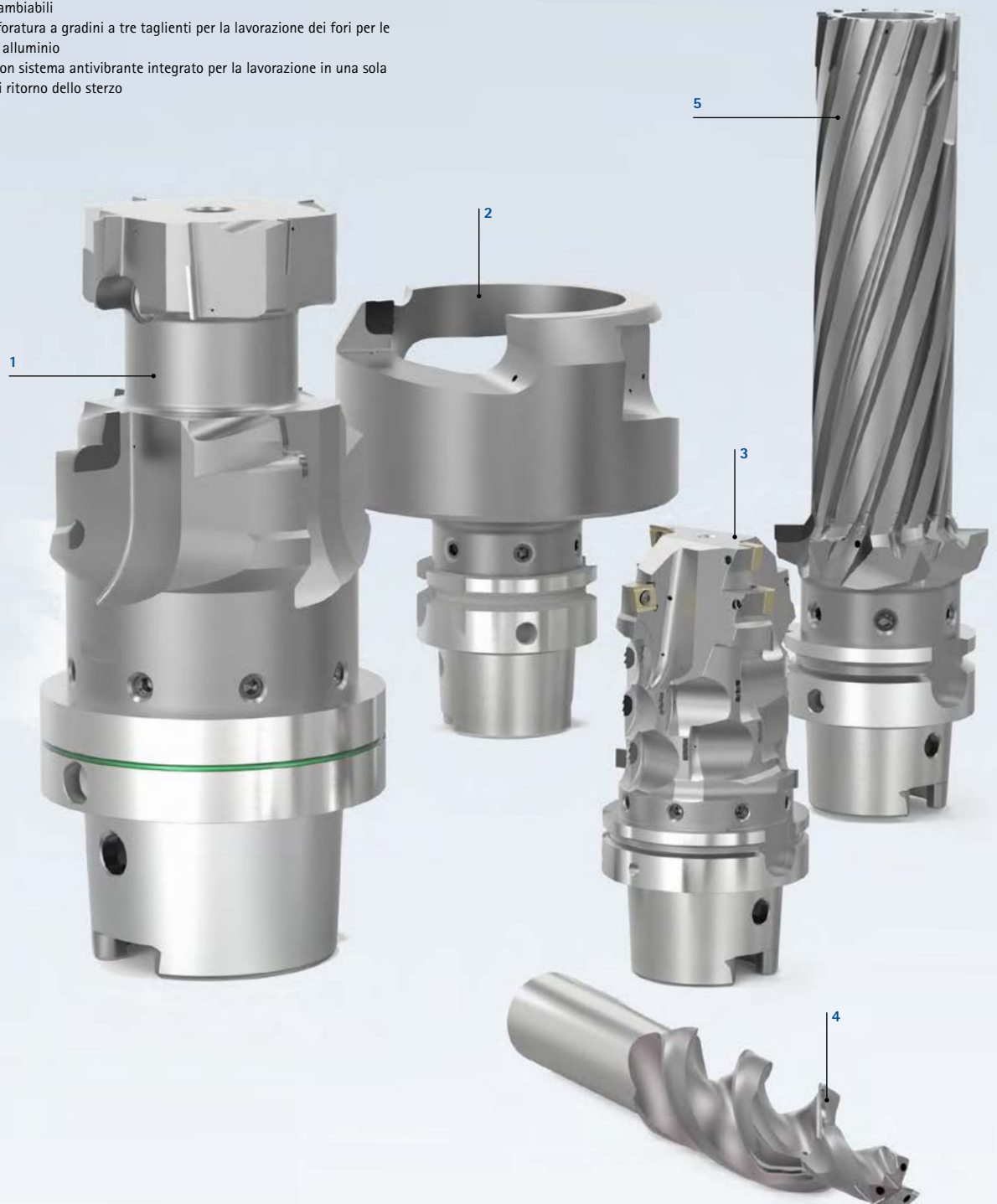



SOLUZIONI SPECIALI

Barenatura con inserti a fissaggio meccanico

Nella progettazione di nuovi processi di lavorazione, nonché per l'ottimizzazione di processi già esistenti, occorre tenere conto di due fattori cruciali: i tempi di lavorazione e il cosiddetto Cost Per Part (CPP). Grazie a utensili combinati intelligenti, a più gradini e a più taglienti, nonché grazie agli utensili per la lavorazione completa dotati di inserti a fissaggio meccanico, è possibile ridurre sensibilmente sia i tempi di lavorazione principali che gli onerosi tempi morti. Per ideare la soluzione ottimale per il cliente si abbinano infatti spesso diversi sistemi di asportazione trucioli, creando i cosiddetti utensili ibridi.

Gli utensili con inserti a fissaggio meccanico MAPAL soddisfano appieno sia i requisiti di sicurezza dei processi che la necessità di un utilizzo semplice e di una buona maneggevolezza. E questo grazie a soluzioni di adattatori intelligenti e precise, oltre che al montaggio veloce e sicuro degli inserti stessi.

Il funzionamento in sicurezza degli utensili muniti di inserti a fissaggio meccanico è garantito da avanzati metodi di costruzione, che assicurano sin dalla fase di progettazione un'attenta prevenzione delle collisioni e il rilevamento di eventuali interferenze. La produzione, realizzata presso modernissimi centri, è garanzia di massima precisione.

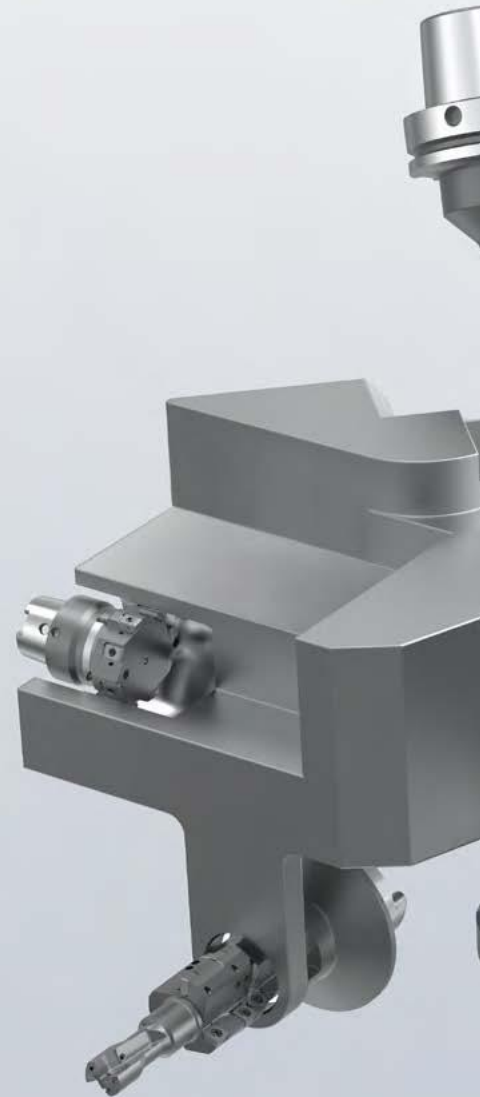

Soluzioni speciali



Soluzioni di processo

- Efficienti utensili per la lavorazione completa abbreviano i tempi di lavoro effettivo e i tempi morti
- Processi ottimizzati riducono il tempo di lavorazione fino al 60 per cento
- Tempi di ciclo ridotti
- Minor consumo energetico
- Maggiore redditività



Costruzione e produzione

- Sviluppo e progettazione di complessi utensili tangenziali grazie ad avanzati metodi di costruzione in 3D e controlli computerizzati
- Sedi inserto e vani truciolo progettati con esattezza
- Produzione realizzata su potenti centri di lavorazione a 5 assi ad alta precisione
- Monitoraggio e controllo da parte di collaboratori esperti
- Rispetto di tolleranze di produzione ad alta precisione
- Reale caratteristica a più taglienti ed elevate prestazioni degli utensili



Struttura modulare

- Utensili combinati con struttura modulare muniti di inserti a fissaggio meccanico
- Lavorazione di intere famiglie di componenti con pochi utensili
- In caso di usura basta sostituire solo la parte usurata dell'utensile
- Grazie all'inserimento degli innesti, come ad esempio l'innesto HSK-C ad alta precisione, le moderne tecniche di produzione consentono di costruire utensili particolarmente complessi
- Più fasi di lavorazione riunite in un unico utensile
- Aumentata produttività

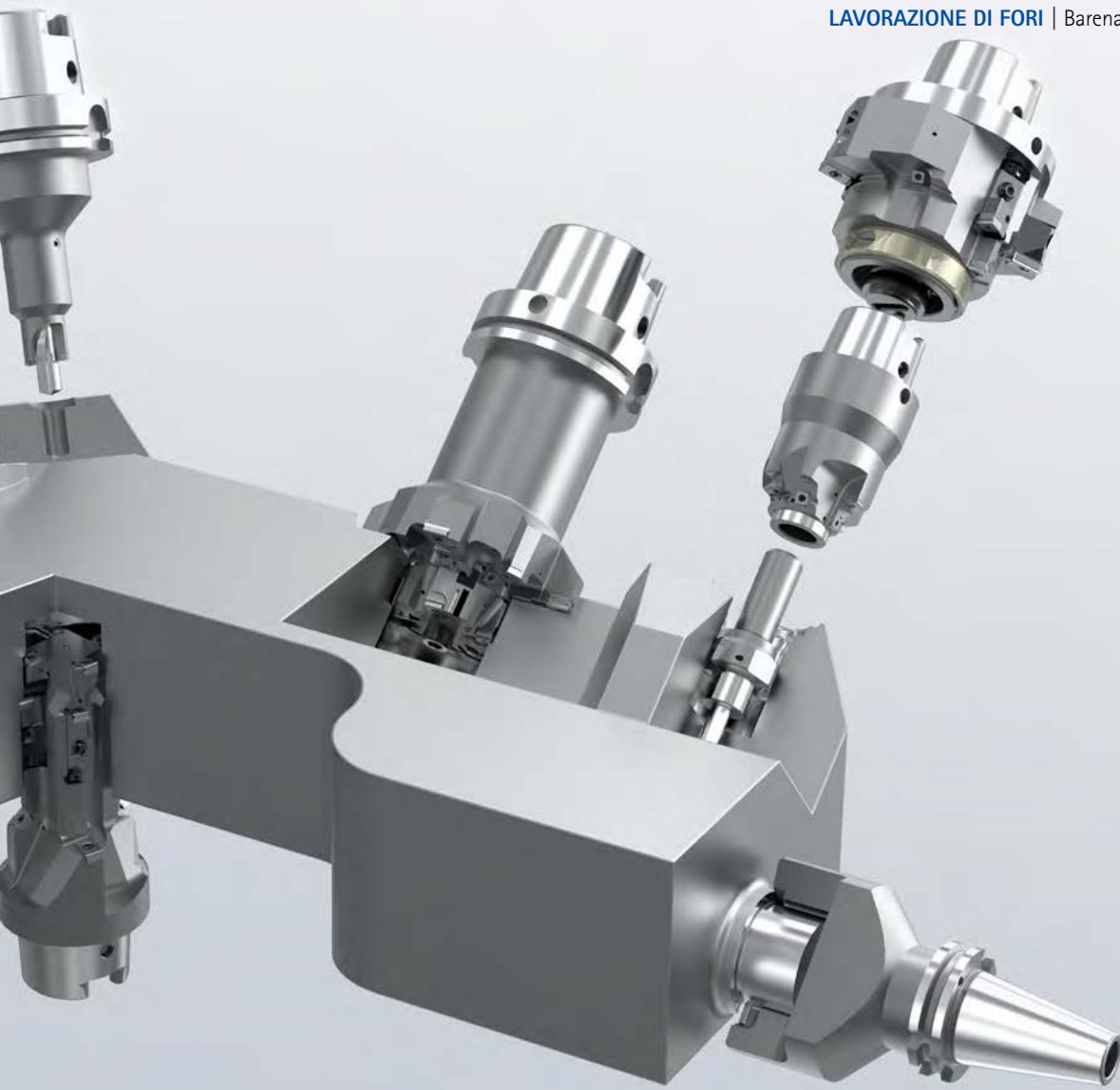

Tecnologia tangenziale

- La tecnologia tangenziale assicura un'elevata efficienza degli utensili di barenatura muniti di inserti a fissaggio meccanico
- Rispetto all'utilizzo di inserti a fissaggio meccanico a montaggio radiale, questa innovativa tecnologia consente l'impiego di più taglienti con lo stesso assorbimento di potenza
- Valori di taglio superiori e maggiore volume di truciolo
- Elevata silenziosità del funzionamento
- Eccellenti durate dell'utensile e ottime qualità del pezzo in lavorazione



Taglienti

- Vasta e ben assortita scelta di geometrie e materiali da taglio
- Il tagliente perfetto per ogni applicazione
- Varie forme e dimensioni
- Sono disponibili tutti i materiali da taglio come metallo duro, ceramica e inserti a fissaggio meccanico con ripor- to in PCD o PcBN
- Elevata redditività e uso efficiente delle risorse
- Sfruttamento ottimale del materiale da taglio grazie a fino a otto taglienti

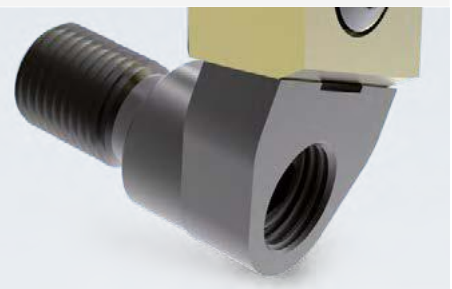

Regolazione esatta

- Sistema di regolazione sviluppato appositamente per garantire massima precisione nel settaggio dei taglienti
- Appoggio stabile grazie al cono di regolazione completamente integrato nel corpo base dell'utensile
- Il tagliente appoggia con un'ampia superficie ssul cono di regolazione, che è dotato di un'apposita inclinazione e può essere movimentato tramite un grano a doppio effetto
- Il grano a doppio effetto garantisce una possibilità di regolazione indiretta, molto precisa e semplice da utilizzare

SOLUZIONI SPECIALI

Barenatura con inserti a fissaggio meccanico (1/2)

Esempi di applicazione di soluzioni speciali con inserti a fissaggio meccanico

- 1 Lavorazione di un foro del rotore nella scatola del compressore in GJL con sistema antivibrante frontale
- 2 Utensile con tecnologia a pattini di guida, per il supporto ottimale nella lavorazione di un foro passante nel mandrino di una macchina a tavola circolare con lunghezza superiore ai 1.000 mm
- 3 Utensile combinato con inserti a fissaggio meccanico e punta in metallo duro integrale a innesto per il fissaggio del supporto del freno e per la lavorazione a più gradini di un supporto per ruota GJS
- 4 La struttura tangenziale consente la svasatura completa del profilo di un disco della turbina in un turbocompressore in materiali resistenti alle alte temperature con lubrificazione minimale
- 5 Strumento personalizzato per la sgrossatura e la semilavorazione di cuscinetti a snodo, inclusa smussatura e fresatura a tuffo, con punta a innesto aggiuntiva
- 6 Utensile combinato in struttura ultra-leggera con elementi del corpo base in CFRP e inserti a fissaggio meccanico di tipo radiale e tangenziale per la lavorazione del tratto principale nella scatola del cambio in alluminio
- 7 Utensile combinato per la lavorazione a più gradini di un cambio per carichi pesanti in GJL



Il sistema antivibrante consente di ottenere qualità superficiali nettamente migliori durante la lavorazione. Il design è adattato alle specifiche operazioni di lavorazione.

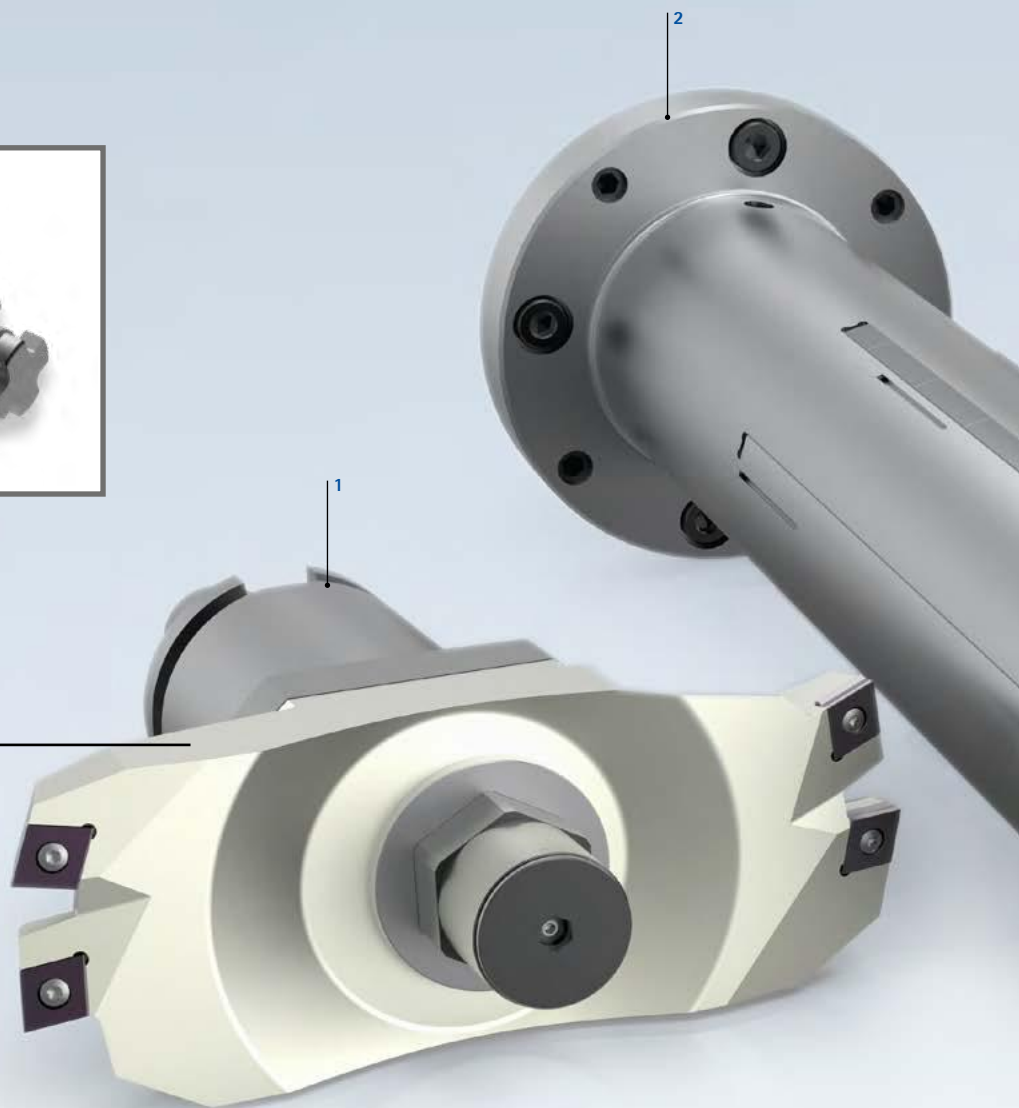



SOLUZIONI SPECIALI

Barenatura con inserti a fissaggio meccanico (2/2)

Esempi di applicazione di soluzioni speciali con inserti a fissaggio meccanico

- 1 Utensile per tornitura in interpolazione con basamenti portastampo e linea di troncatura continua per la lavorazione del profilo di penetrazione del collegamento del nastro a V alla scatola di una turbina (turbocompressore).
- 2 Lavorazione preliminare e semifinitura del foro principale della scatola di una turbina (turbocompressore). Sei caratteristiche di lavorazione e un taglio di controllo con un solo utensile.
- 3 Utensile combinato con inserti a fissaggio tangenziale e pattini di guida in cermet e PCD.
- 4 Lavorazione di finitura di scatole per turbine e compressori con utensile di comando mecatronico TOOLTRONIC®.
- 5 Lavorazione del foro principale con utensile combinato ISO per scanalatura, barenatura di precisione e svasatura.





SOLUZIONI SPECIALI

Inserti in versione speciale

Per lavorare in modo razionale contorni complessi con elevata precisione di forma, vengono spesso impiegati taglienti di profilatura.

I taglienti MAPAL offrono infinite opzioni in quanto a forma, materiale da taglio e rivestimento. Grazie a moderni dispositivi di produzione, i taglienti MAPAL in versione speciale garantiscono massima precisione e grande flessibilità.

Sono inoltre disponibili anche diversi inserti con riporto in PCD e PcBN. Montati in sedi ad alta precisione, gli utensili MAPAL assicurano ottimi risultati in termini sia qualitativi che economici.





VANTAGGI

- Elevata sicurezza dei processi in caso di forme e geometrie che seguono il contorno
- Risparmio di onerose sequenze di lavorazione
- Impiego di più taglienti nella produzione di profili complessi





ModulBore

Elevata flessibilità nella barenatura e nella barenatura di precisione

Con la gamma ModulBore, MAPAL offre un sistema comune per la lavorazione preliminare e la finitura di fori in un range di diametro da 6 a 1.000 mm.

Grazie alla struttura modulare, il sistema è molto flessibile e configurabile in base all'operazione di lavorazione specifica. Per la sgrossatura sono disponibili utensili a due taglienti. Grazie alla dentatura frontale per l'innesto dei supporti dei taglienti, gli utensili risultano molto stabili e particolarmente performanti. L'impiego di inserti a fissaggio meccanico con geometria di base positiva, cavità per trucioli tornite, nonché adduzione interna del refrigerante garantisce vaste possibilità di impiego, un'ottima sicurezza e massima semplicità di utilizzo.

Le testine per barenatura di precisione ModulBore sono disponibili già a partire da un diametro di 6 mm. Caratterizzati da un'elevata precisione e da una struttura robusta, questi utensili sono semplici da utilizzare e sono dotati di adduzione interna del refrigerante. La regolazione fine delle testine avviene in entrambe le direzioni, in modo estremamente preciso e senza il cosiddetto effetto di scivolamento "stick-slip".

La gamma ModulBore è adattabile alle singole esigenze del cliente e non è pertanto disponibile a magazzino.

ModulBore

Introduzione	614
Riepilogo sistema	618
ModulBore - Barenatura	620
ModulBore - Barenatura di precisione	627
Adattatori	636

ModulBore - Barenatura

Ø 22 - 115 mm

Utensile a due taglienti con sistema di foratura modulare ModulBore (MBS) in sette misure per supporti (cartucce per inserti a fissaggio meccanico).

Ø 87 - 202 mm

Teste di barenatura con struttura a ponte. Ripartito su cinque ponti per supporti (cartucce per inserti a fissaggio meccanico).

Ø 200 - 520 mm

Teste di barenatura con struttura a ponte. Ripartito su quattro ponti per l'equipaggiamento di slitte per cartucce ISO comunemente reperibili in commercio.

Ø 358 - 1.000 mm

Teste di barenatura con struttura a ponte (grande range di tornitura). Ripartito su otto ponti per l'equipaggiamento di slitte per cartucce ISO comunemente reperibili in commercio.



* Quantità di ordine necessaria: 2 pezzi

Utensili di barenatura



Utensili a due taglienti con sistema di foratura modulare MBS

Per la lavorazione di sgrossatura nel range di diametro da 22 a 115 mm sono disponibili utensili a due taglienti. Grazie alla dentatura frontale per l'innesto dei supporti degli inserti, il sistema risulta molto stabile e particolarmente performante. L'impiego di inserti a fissaggio meccanico con geometria di base positiva, cavità per trucioli tornite, nonché adduzione interna del refrigerante garantisce vaste possibilità di impiego, un'ottima sicurezza e massima semplicità di utilizzo.

Gli utensili a due taglienti sono disponibili in versione sia modulare sia monoblocco, con innesto HSK oppure SK.

* Quantità di ordine necessaria: 2 pezzi



Teste di barenatura con modulo ponte e cartuccia ISO

Le teste di barenatura con modulo ponte sono disponibili nel range da 87 a 1.000 mm. I moduli ponte a partire da un diametro di 200 mm sono dotati di cartucce ISO, che vengono inserite frontalmente sui ponti delle slitte con dentatura. Per ottimizzare il peso, i moduli ponte nel range di diametro da 358 a 1.000 mm vengono realizzati in alluminio.

ModulBore – Barenatura di precisione

Ø 10 – 28 mm

Testine per barenatura di precisione con barra alesatrice

Ø 14 – 23 mm

Bareno di precisione

Ø 21 – 115 mm

Testina per barenatura di precisione con sistema di foratura modulare MBS

Ø 87 – 202 mm

Testine per barenatura di precisione con struttura a ponte. Ripartito su quattro ponti per l'equipaggiamento di slitte per cartucce per barenatura di precisione ModulBore.

Ø 200 – 520 mm

Testine per barenatura di precisione con struttura a ponte. Ripartito su quattro ponti per l'equipaggiamento di slitte per cartucce per barenatura di precisione ModulBore.

Ø 358 – 1.000 mm

Testine per barenatura di precisione con struttura a ponte (grande range di tornitura). Ripartito su otto ponti per l'equipaggiamento di slitte per cartucce per barenatura di precisione ModulBore.



Utensili per barenatura di precisione



Testina per barenatura di precisione con barra alesatrice

Le testine per barenatura di precisione ModulBore sono disponibili già a partire da un diametro di 6 mm. Caratterizzate da un'elevata precisione e dalla struttura robusta, sono semplici da utilizzare e dispongono anche di un sistema di adduzione interna del refrigerante. La regolazione fine delle testine avviene in entrambe le direzioni, in modo estremamente preciso e senza il cosiddetto effetto di scivolamento "stick-slip".

Le testine per barenatura di precisione sono disponibili in versione sia modulare sia monoblocco, con innesto HSK oppure SK.



Testina per barenatura di precisione con modulo ponte e cartuccia

A partire dal diametro 87 mm le testine per barenatura di precisione sono realizzate con modulo ponte. Sui moduli ponte si trovano guide dotate di cartucce regolabili. Per i diametri maggiori, gli utensili a ponte sono realizzati con un solo tagliente. La slitta, posizionata sul lato opposto, è utile per compensare lo sbilanciamento. Per ottimizzare il peso, i moduli ponte nel range di diametro da 358 a 1.000 mm vengono realizzati in alluminio.

ModulBore-Plus – Barenatura di precisione

Gli utensili ModulBore-Plus con regolazione fine sono caratterizzati da un meccanismo di regolazione semplice e preciso. Questo consente un posizionamento ben definito ed esente da errori direttamente sulla macchina, mediante chiavi torx standard. L'elevata precisione e il semplice utilizzo consentono di ridurre i tempi morti nei processi di barenatura di precisione, ottenere qualità migliori e incrementare la produttività.

MODULBORE-PLUS

- **Regolazione fine:**
2 μm per tratto parziale riferiti al diametro
- **Errore di inversione:**
< 2 μm

VANTAGGI

- Lettura dei valori senza errori (non è necessario l'impiego di un nonio)
- Nessun effetto di scivolamento "stick-slip"
- Richiede scarsa manutenzione
- Facilità di montaggio
- Robustezza e lunga durata: tre anni di garanzia

Bareno di precisione

Il bareno di precisione ModulBore-Plus è idoneo all'utilizzo nella produzione in serie, anche di grandi entità, e consente di massimizzare le durate.

Testina per barenatura di precisione

L'affidabile testina per barenatura di precisione ModulBore-Plus è adatta alla barenatura di precisione, dalla produzione di prototipi fino alle grandi produzioni in serie. L'unità di regolazione grossolana supplementare conferisce alla testina di foratura un raggio d'azione variabile fino a 9 mm. L'intera gamma di prodotti consente di lavorare fori di diametri da 21 a 115 mm.

Cartuccia per barenatura di precisione

Le cartucce per barenatura di precisione ModulBore-Plus sono idonee all'impiego in strumenti personalizzati ad uno o più taglienti, oppure in ponti per barenatura di precisione nel campo delle forature di grandi dimensioni. Non necessitano di alcun adattamento del mandrino della macchina.

Sistemi di utensili ModulBore-Plus

Bareno di precisione da \varnothing 14 a 23 mm

Testina per barenatura di precisione
 \varnothing da 21 a 115 mm



Cartuccia per barenatura di precisione



ModulBore - Adattatori

Innesto MBS

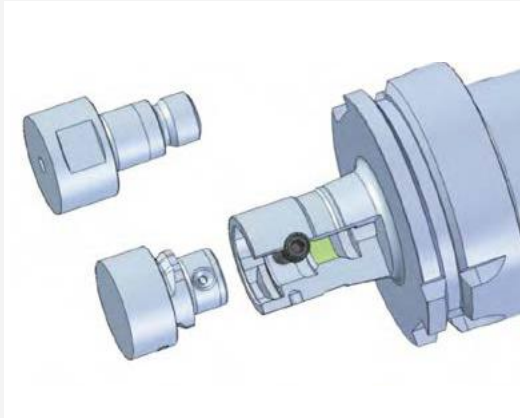

L'innesto MBS è la caratteristica centrale del sistema di foratura modulare ModulBore. Grazie al giunto a baionetta, che pone in essere un contatto cilindrico con superficie di appoggio piana, è possibile trasmettere elevate forze di coppia. Due viti di serraggio radiali consentono un pre-tensionamento del giunto e la rotazione dell'utensile in entrambe le direzioni.

VANTAGGI

- Semplice utilizzo, montaggio e smontaggio facile
- Giunto a baionetta ad alta precisione con orientamento dei taglienti
- Elevata precisione di concentricità grazie al rasamento
- Adduzione interna del refrigerante attraverso l'innesto fino al tagliente
- Compatibile con Starflex RFX

Adattatori MBS



Gli adattatori MBS offrono la possibilità di adattare il collegamento lato macchina per trasformarlo in collegamento MBS. In questo modo è possibile usufruire senza limitazioni del vasto assortimento ModulBore. L'assortimento standard comprende i collegamenti più diffusi come i codoli conici cavi (HSK) e diversi coni verticali (SK/BT) in molte dimensioni e lunghezze nominali. Le prolunghere e i riduttori MBS aumentano inoltre la flessibilità dell'intero sistema. Ulteriori adattatori possono essere prodotti come strumenti personalizzati.

Mandrini a innesto



I mandrini portafresa combinati a innesto/con attacco a croce costituiscono la base per molte varianti di utensili ponte ModulBore. L'assortimento standard include i collegamenti più diffusi come i codoli conici cavi (HSK), svariati coni verticali (SK/BT) e MBS in molte dimensioni e lunghezze nominali. Inoltre è possibile dotare altri collegamenti macchina, come ad esempio KM secondo DIN ISO 26622 di utensili ponte come mandrini portafresa a innesto combinati.

ModulBore - Riepilogo sistema

ModulBore | Adattatori

Adattatori MBS

Pagina 636 - 638

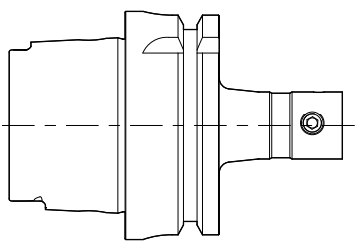
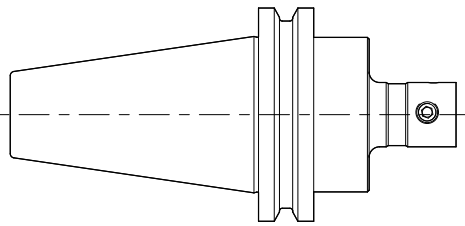
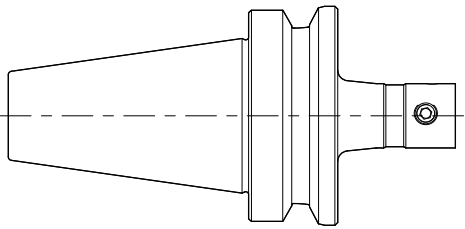

Prolunghe MBS

Pagina 639

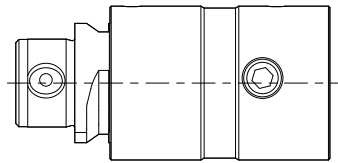

Riduttori MBS

Pagina 640

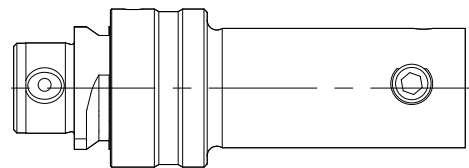

Mandrini con attacco a croce MBS

Pagina 641

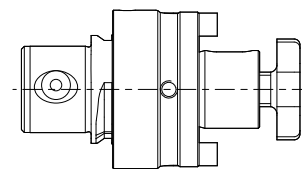

Mandrini a innesto

vedere catalogo SISTEMI DI SERRAGGIO

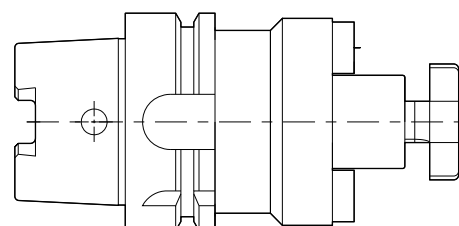

▶ Innesto MBS

▶ Mandrino a innesto

ModulBore - Barenatura

Utensili a due taglienti con sistema di foratura modulare MBS

Pagina 620

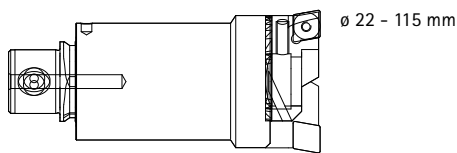

Disponibile anche come utensile monoblocco!

Testina per barenatura con modulo ponte

Pagina 622

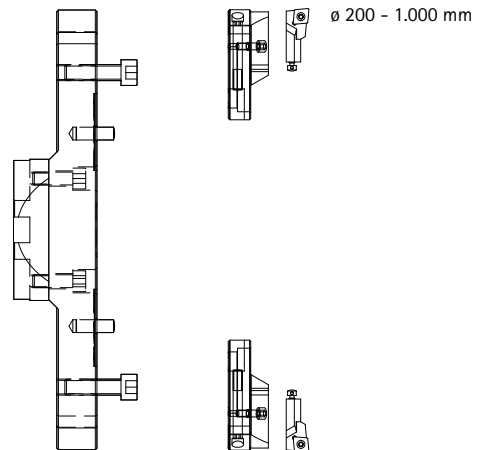
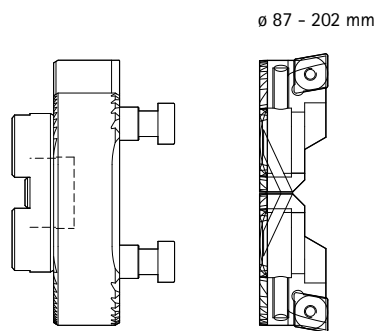

ModulBore | Barenatura di precisione

Testina per barenatura di precisione ModulBore

con sistema di foratura modulare MBS

Pagina 627

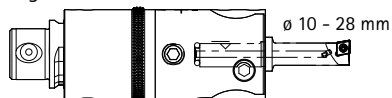

Disponibile anche come utensile monoblocco con innesto HSK/SK!

Testina per barenatura di precisione ModulBore-Plus

con sistema di foratura modulare MBS

Pagina 630

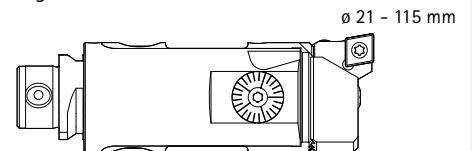

Testina per barenatura di precisione ModulBore

con modulo ponte

Pagina 631

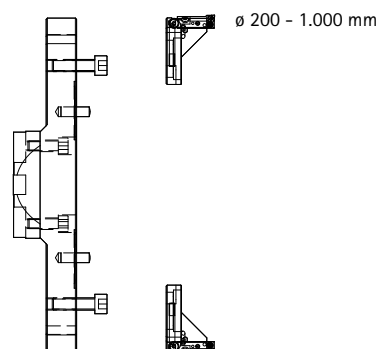
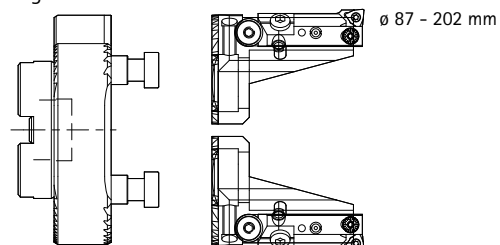

ModulBore - Utensili a due taglienti con sistema di foratura modulare MBS

Utensile di barenatura per la lavorazione di sgrossatura, attacco senza cartucce per inserti a fissaggio meccanico

Ø 22 - 115 mm

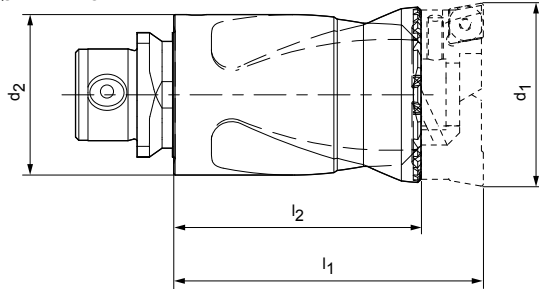

d_1 min. - max.	d_2 Dimensione MBS	l_1	l_2	sw	Specifiche	Codice
22 - 30	18,5	40	27,7	17	MBO100-022030-Z2-MBS185	30415217
30 - 39	24,5	50	37,7	22	MBO100-030039-Z2-MBS254	30415218
39 - 50	32	65	48,7	27	MBO100-039050-Z2-MBS320	30415219
50 - 67	42	90	68,2	36	MBO100-050067-Z2-MBS420	30415220
67 - 88	55	115	90,7	46	MBO100-067088-Z2-MBS550	30415221
88 - 115	72	150	113,7	60	MBO100-088115-Z2-MBS720	30415222

Tempi di consegna su richiesta.

Esempio

Riepilogo sistema - Utensili a due taglienti con sistema di foratura modulare MBS

Ø 22 - 115 mm

Adattatori MBS

Utensili a due taglienti con sistema di foratura modulare MBS

Cartucce per inserti a fissaggio meccanico (supporti)

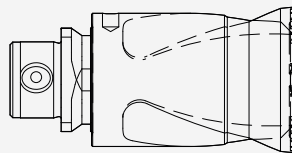
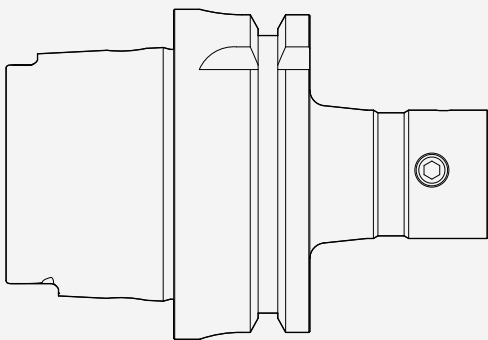

ModulBore - Cartucce per inserti a fissaggio meccanico per utensili a due taglienti

Ø 22 - 115 mm

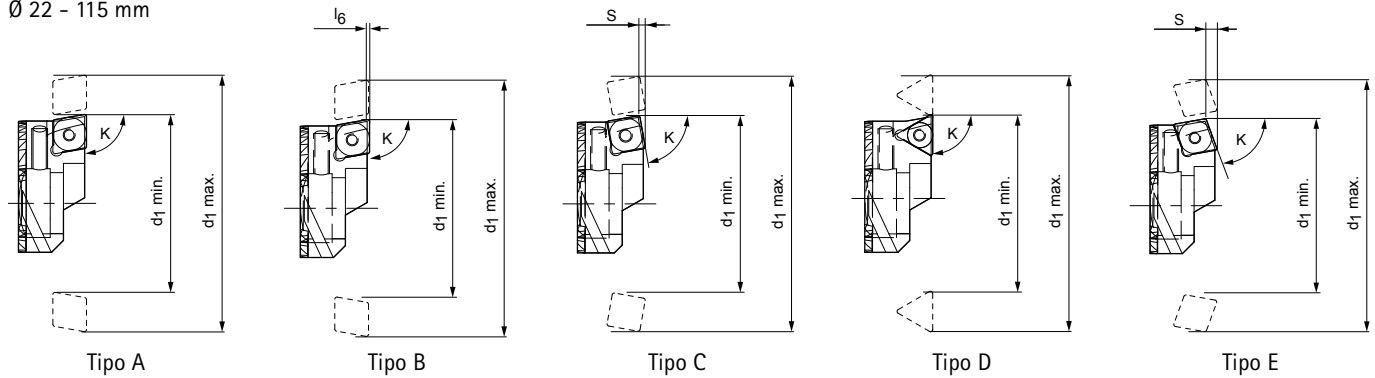

d_1 min. - max.	Tipo	K	Spostamento altezza l_6	S	Inserto a fissag- gio meccanico	Specifiche	Codice
22 - 30	A	90°			CC/CP.. 0602	IC-MBO100-022030-A90-C_06	30415185
	B	90°	0,3		CC/CP.. 0602	IC-MBO100-022030-B90-C_06	30415186
	E	70°		2	CC/CP.. 0602	IC-MBO100-022030-E70-C_06	30415187
30 - 39	A	90°			CC/CP.. 0602	IC-MBO100-030039-A90-C_06	30415188
	B	90°	0,3		CC/CP.. 0602	IC-MBO100-030039-B90-C_06	30415189
	C	80°		2	SP.. 0703	IC-MBO100-030039-C80-S_07	30415190
	E	70°		2	CC/CP.. 0602	IC-MBO100-030039-E70-C_06	30415191
39 - 50	A	90°			CC/CP.. 09T3	IC-MBO100-039050-A90-C_09	30415192
	B	90°	0,3		CC/CP.. 09T3	IC-MBO100-039050-B90-C_09	30415193
	C	80°		1,5	SC/SP.. 09T3	IC-MBO100-039050-C80-S_09	30415194
	D	90°			TC/TP.. 09T3	IC-MBO100-039050-D90-T_09	30415195
	E	70°		3,1	CC/CP.. 09T3	IC-MBO100-039050-E70-C_09	30415196
50 - 67	A	90°			CC/CP.. 1204	IC-MBO100-050067-A90-C_12	30415197
	B	90°	0,3		CC/CP.. 1204	IC-MBO100-050067-B90-C_12	30415198
	C	80°		2,1	SC/SP.. 09T3	IC-MBO100-050067-C80-S_09	30415199
	D	90°			TC/TP.. 09T3	IC-MBO100-050067-D90-T_09	30415200
	E	70°		4,1	CC/CP.. 1204	IC-MBO100-050067-E70-C_12	30415201
67 - 88	A	90°			CC/CP.. 1204	IC-MBO100-067088-A90-C_12	30415202
	B	90°	0,3		CC/CP.. 1204	IC-MBO100-067088-B90-C_12	30415203
	C	80°		2,1	SC/SP.. 1204	IC-MBO100-067088-C80-S_12	30415204
	D	90°			TNM.. 16T3	IC-MBO100-067088-D90-T_16	30415205
	E	70°		4,1	CC/CP.. 1204	IC-MBO100-067088-E70-C_12	30415206
88 - 115	A	90°			CC/CP.. 1204	IC-MBO100-088115-A90-C_12	30415207
	B	90°	0,3		CC/CP.. 1204	IC-MBO100-088115-B90-C_12	30415208
	C	80°		2,5	SC/SP.. 1204	IC-MBO100-088115-C80-S_12	30415209
	D	90°			TNM.. 2204	IC-MBO100-088115-D90-T_22	30415210
	E	70°		4,1	CC/CP.. 1204	IC-MBO100-088115-E70-C_12	30415211

Quantità di ordine necessaria: 2 pezzi

Tempi di consegna su richiesta.

ModulBore - Testina per barenatura con modulo ponte

Utensile di barenatura per la lavorazione di sgrossatura, attacco senza cartucce per inserti a fissaggio meccanico

Ø 87 - 202 mm

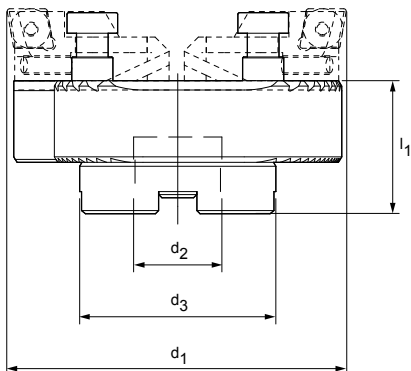

d_1 min. - max.	d_2	d_3	l_1	Specifiche	Codice
87 - 110	27	61,5	42	MB0110-087110-Z2-CA27	30415224
109 - 133	27	61,5	42	MB0110-109133-Z2-CA27	30415225
132 - 156	27	62	42	MB0110-132156-Z2-CA27	30415226
155 - 179	27	62	42	MB0110-155179-Z2-CA27	30415227
178 - 202	27	62	42	MB0110-178202-Z2-CA27	30415228

Tempi di consegna su richiesta.

Esempio

Riepilogo sistema - Testina di barenatura con modulo ponte

Ø 87 - 202 mm

Adattatori MBS

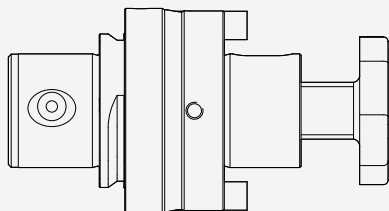

Modulo ponte

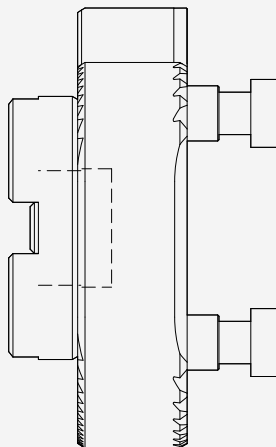

Cartucce per inserti a fissaggio meccanico (supporti)

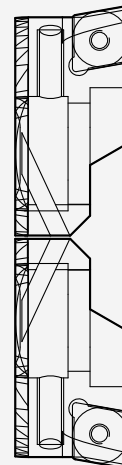

ModulBore - Cartucce per inserti a fissaggio meccanico per utensili a due taglienti

Ø 87 - 202 mm

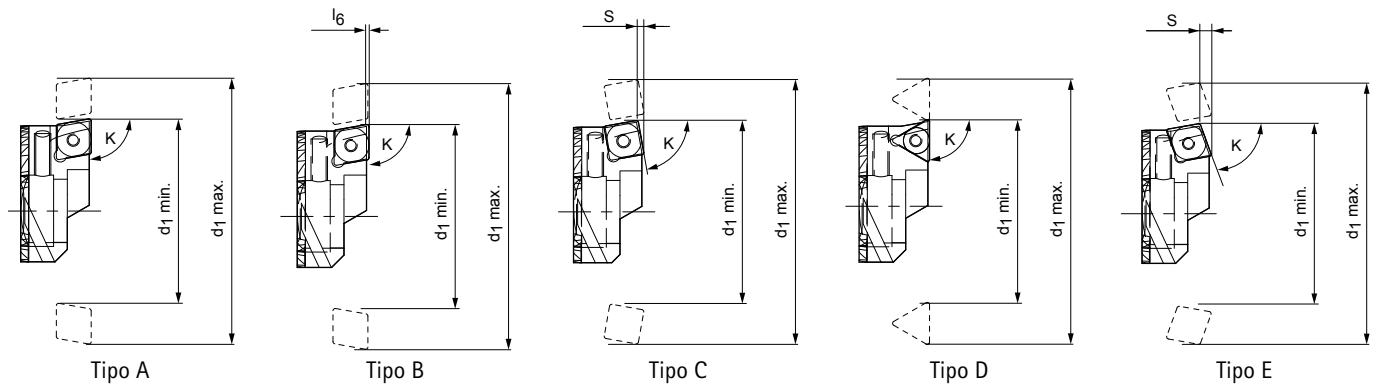

d_1 min. - max.	Tipo	K	Spostamento altezza l_6	S	Inserto a fissaggio meccanico	Specifiche	Codice
87 - 202	A	90°			CC/CP.. 1204	IC-MBO100-067088-A90-C_12	30415202
	B	90°	0,3		CC/CP.. 1204	IC-MBO100-067088-B90-C_12	30415203
	C	80°		2,1	SC/SP.. 1204	IC-MBO100-067088-C80-S_12	30415204
	D	90°			TNM.. 16T3	IC-MBO100-067088-D90-T_16	30415205
	E	70°			4,1	CC/CP.. 1204	IC-MBO100-067088-E70-C_12

Quantità di ordine necessaria: 2 pezzi
Tempi di consegna su richiesta.

ModulBore - Testina per barenatura con modulo ponte

Utensile di barenatura per la lavorazione di sgrossatura, senza slitta e cartuccia
 Ø 200 - 520 mm

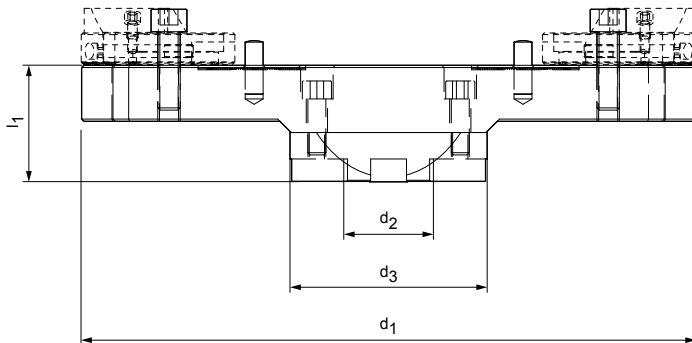

d_1 min. - max.	d_2	d_3	l_1	Specifiche	Codice
200 - 280	40	88	51	MB0120-200280-Z2-CA40	30415229
280 - 360	40	88	51	MB0120-280360-Z2-CA40	30415230
360 - 440	40	88	61	MB0120-360440-Z2-CA40	30415231
440 - 520	40	88	61	MB0120-440520-Z2-CA40	30415232

Tempi di consegna su richiesta.

ModulBore - Testina per barenatura con modulo ponte

Utensile di barenatura di sgrossatura, versione rafforzata in alluminio, senza slitte e cartuccia
 Ø 358 - 1.000 mm

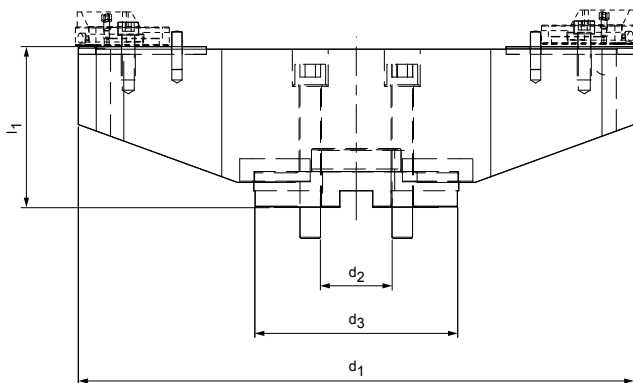

d_1 min. - max.	d_2	d_3	l_1	Specifiche	Codice
358 - 440	60	130	91	MB0130-358440-Z2-CA60	30415233
438 - 520	60	130	126	MB0130-438520-Z2-CA60	30415234
518 - 600	60	130	126	MB0130-518600-Z2-CA60	30415235
598 - 680	60	130	126	MB0130-598680-Z2-CA60	30415236
678 - 760	60	130	126	MB0130-678760-Z2-CA60	30415237
758 - 840	60	130	126	MB0130-758840-Z2-CA60	30415238
838 - 920	60	130	126	MB0130-838920-Z2-CA60	30415239
918 - 1000	60	130	126	MB0130-918000-Z2-CA60	30415240

Tempi di consegna su richiesta.

Misure in mm.

ModulBore - Slitte per Cartuccia ISO

Ø 200 - 1.000 mm

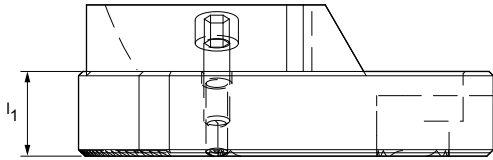

Per ø utensile d ₁	l ₁	Specifiche	Codice
200 - 1.000	19,4	SL-MBO140-2001000	30415309

Tempi di consegna su richiesta.

ModulBore - Cartuccia ISO

Ø 200 - 1.000 mm

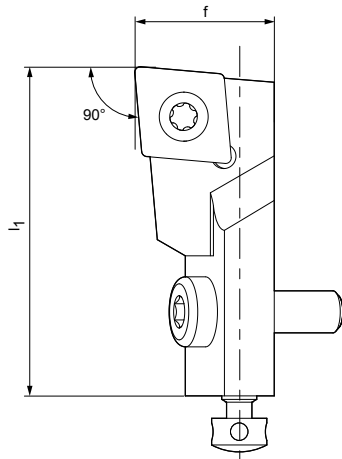

Tipo A

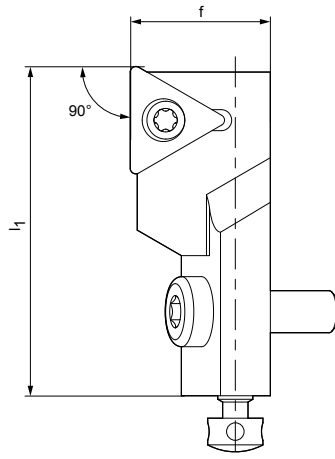

Tipo B

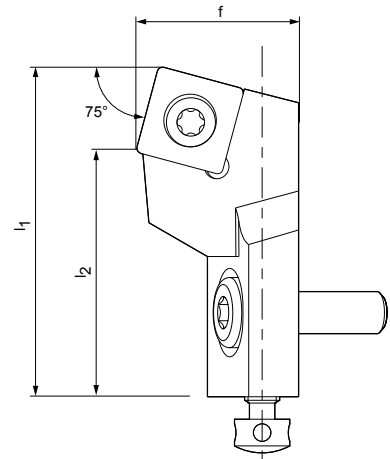

Tipo C

Tipo	f	l ₁	l ₂	Inserti a fissaggio meccanico	Specifiche	Codice
A	20	47	-	CC...1204	SCLCL12CA-12	30011071
B	20	47	-	TC16T3	STGCL12CA-16	30011077
C	20	47	35,409	SC...1204	SSRCL12CA-12	30011103

Tempi di consegna su richiesta.

Accessori vedere pagina 660.

Misure in mm.

Esempio

Riepilogo sistema - Testina di barenatura con modulo ponte

Ø 200 - 1.000 mm

Adattatori

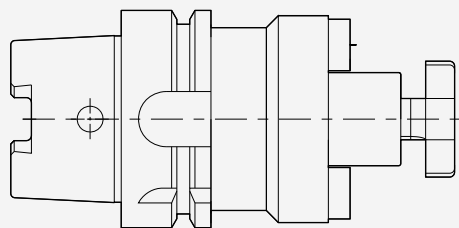

Modulo ponte

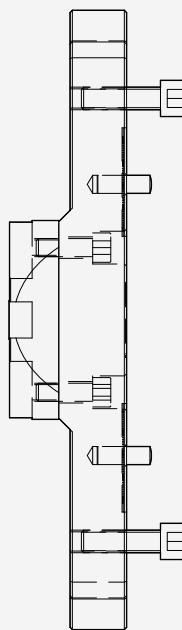

Slitte + cartuccia ISO

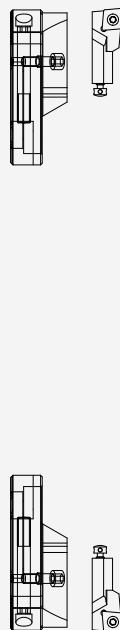

ModulBore - Testina per barenatura di precisione

Utensile per tornitura interna di finitura, corpo utensile senza barra alesatrice

Ø 10 - 28 mm

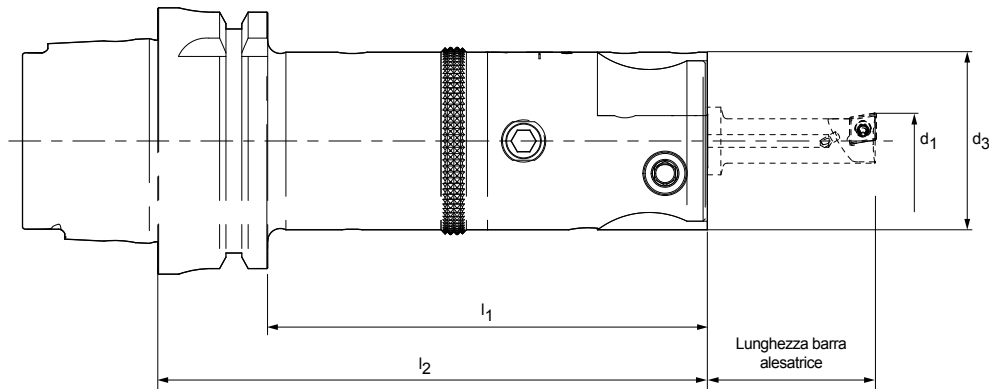

d_1 min. - max.	Codolo	d_3	l_1	l_2	Specifiche	Codice
10 - 28	MBS	42		95	MBO201-006028-Z1-MBS420	30415248
	MAS BT40	42	76	103	MBO201-006028-Z1-BT040	30415241
	SK40	42	84	103	MBO201-006028-Z1-SK040	30415249
	HSK-A40	42	110	130	MBO201-006028-Z1-HSK-A040	30415242
	HSK-A50	42	104	130	MBO201-006028-Z1-HSK-A050	30415243
	HSK-A63	42	104	130	MBO201-006028-Z1-HSK-A063	30415244
	HSK-A80	42	104	130	MBO201-006028-Z1-HSK-A080	30415245
	HSK-A100	42	101	130	MBO201-006028-Z1-HSK-A100	30415246
	KM40	42		100	MBO201-006028-Z1-KM40	30415247

Regolazione grossolana $d_1 = 3$ mm | Regolazione fine $d_1 = 0,4$ mm

Tempi di consegna su richiesta.

Esempio

Riepilogo sistema MBS - Testina per barenatura di precisione

Ø 10 - 28 mm

Adattatori

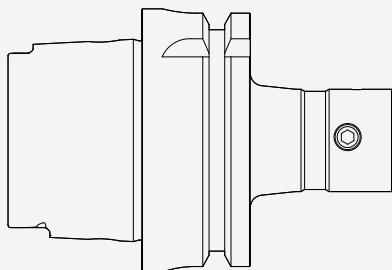

Testina per barenatura di precisione
con sistema di foratura modulare MBS

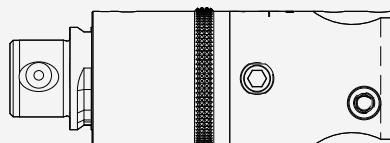

Barra alesatrice

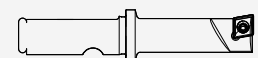

ModulBore - Bareno per testina per barenatura di precisione

Bareno per testina per barenatura di precisione, con adduzione interna del refrigerante
 Ø 10 - 28 mm

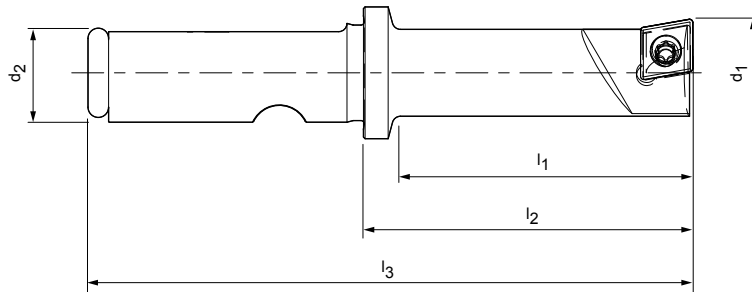

d_1 min. - max.	d_2	l_1	l_2	l_3	Inserto a fissaggio meccanico	Specifiche	Codice
10 - 13	12	30	35	70	CC.. 0602	MB0211-010013-Z1-22	30415260
13 - 16	12	35	40	75	CC.. 0602	MB0211-013016-Z1-22	30415261
16 - 19	12	40	45	80	CC.. 0602	MB0211-016019-Z1-22	30415262
19 - 22	12	50	55	90	CC.. 0602	MB0211-019022-Z1-22	30415263
22 - 25	12	60	65	100	CC.. 0602	MB0211-022025-Z1-22	30415264
25 - 28	12	70	75	110	CC.. 0602	MB0211-025028-Z1-22	30415265

Tempi di consegna su richiesta.

ModulBore-Plus – Bareno di precisione

Utensile per mandrino per la lavorazione di finitura, con adduzione interna del refrigerante
 Ø 14 - 23 mm

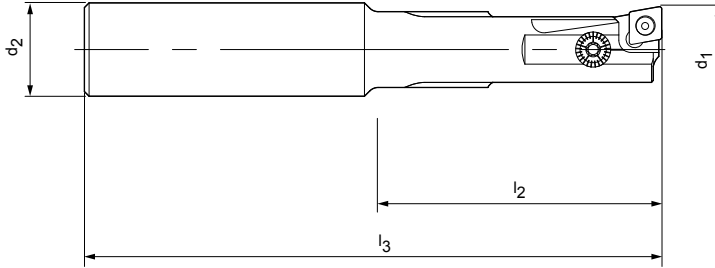

d ₁	d ₂	l ₂	l ₃	Inserto a fissaggio meccanico	Specifiche	Codice
14,0	16	48	99	CC.. 0602	MB0311-0140-Z1-WC16	30415266
14,5	16	48	99	CC.. 0602	MB0311-0145-Z1-WC16	30415267
15,0	16	48	99	CC.. 0602	MB0311-0150-Z1-WC16	30415268
15,5	16	48	99	CC.. 0602	MB0311-0155-Z1-WC16	30415269
16,0	20	54	107	CC.. 0602	MB0311-0160-Z1-WC20	30415270
16,5	20	54	107	CC.. 0602	MB0311-0165-Z1-WC20	30415271
17,0	20	54	107	CC.. 0602	MB0311-0170-Z1-WC20	30415272
17,5	20	54	107	CC.. 0602	MB0311-0175-Z1-WC20	30415273
18,0	20	60	113	CC.. 0602	MB0311-0180-Z1-WC20	30415274
18,5	20	60	113	CC.. 0602	MB0311-0185-Z1-WC20	30415275
19,0	20	60	113	CC.. 0602	MB0311-0190-Z1-WC20	30415276
19,5	20	60	113	CC.. 0602	MB0311-0195-Z1-WC20	30415277
20,0	20	70	125	CC.. 0602	MB0311-0200-Z1-WC20	30415278
20,5	20	70	125	CC.. 0602	MB0311-0205-Z1-WC20	30415279
21,0	20	70	125	CC.. 0602	MB0311-0210-Z1-WC20	30415280
21,5	20	70	125	CC.. 0602	MB0311-0215-Z1-WC20	30415281
22,0	20	70	125	CC.. 0602	MB0311-0220-Z1-WC20	30415282
22,5	20	70	125	CC.. 0602	MB0311-0225-Z1-WC20	30415284
23,0	20	70	125	CC.. 0602	MB0311-0230-Z1-WC20	30415283

Range di regolazione diametro nominale d₁ $\begin{matrix} +0,3 \text{ mm} \\ -0,1 \text{ mm} \end{matrix}$

Tempi di consegna su richiesta.

ModulBore-Plus - Testina per barenatura di precisione con MBS

Utensile per mandrino per la lavorazione di finitura, con adduzione interna del refrigerante
 Ø 21 - 115 mm

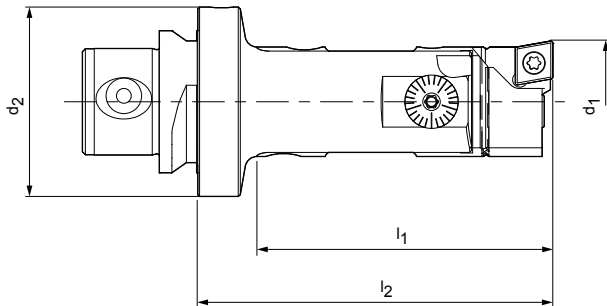

Disponibile su richiesta

d_1 min. - max.	d_2 Dimensione MBS	l_1	l_2	Inserto a fissaggio meccanico	Specifiche	Codice
21 - 29	32	50	60	CC.. 0602	MBO401-021029-Z1-MBS320	30415285
29 - 39	24,5	65	65	CC.. 0602	MBO401-029039-Z1-MBS245	30415286
38 - 50	32	75	75	CC.. 0602	MBO401-038050-Z1-MBS320	30415287
50 - 65	42	95	95	CC.. 0602	MBO401-050065-Z1-MBS420	30415289
65 - 88	55	120	120	CC.. 0602	MBO401-065088-Z1-MBS550	30415291
88 - 115	72	150	150	CC.. 0602	MBO401-088115-Z1-MBS720	30415294

Regolazione grossolana d_1 vedere tabella | Regolazione fine $d_1 = 0,4$ mm
 Tempi di consegna su richiesta.

ModulBore – Testina per barenatura di precisione con modulo ponte

Utensile per mandrino per la lavorazione di finitura, senza slitte e cartuccia

Ø 87 - 202 mm

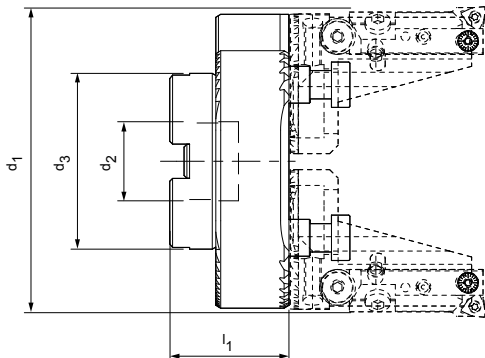

d_1 min. - max.	d_2	d_3	l_1	Specifiche	Codice
87 - 110	27	61,5	42	MB0110-087110-Z2-CA27	30415224
109 - 133	27	61,5	42	MB0110-109133-Z2-CA27	30415225
132 - 156	27	62	42	MB0110-132156-Z2-CA27	30415226
155 - 179	27	62	42	MB0110-155179-Z2-CA27	30415227
178 - 202	27	62	42	MB0110-178202-Z2-CA27	30415228

Tempi di consegna su richiesta.

ModulBore – Slitte per cartuccia per barenatura di precisione

Ø 87 - 202 mm

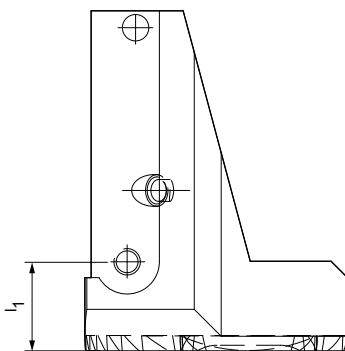

Per ø utensile d_1	l_1	Specifiche	Codice
87 - 202	16,9	SL-MB0150-087202	30415310

Tempi di consegna su richiesta.

Esempio

Riepilogo sistema - Testina di barenatura di precisione con modulo ponte

Ø 87 - 202 mm

Adattatori

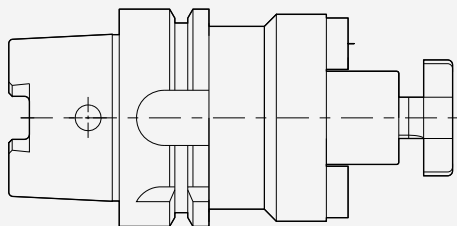

Modulo ponte

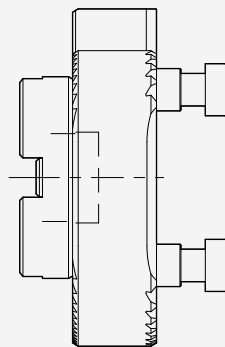

Slitte + portainsero corto per barenatura di precisione

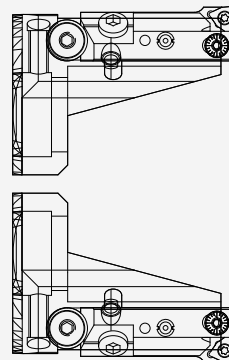

ModulBore – Testina per barenatura di precisione con modulo ponte

Utensile per mandrino per la lavorazione di finitura, senza slitte e cartuccia
 Ø 200 - 520 mm

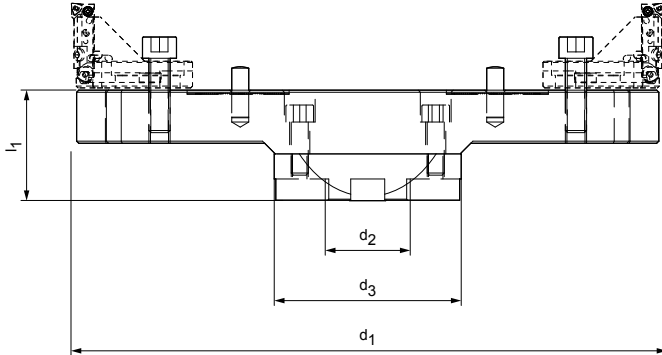

d_1 min. - max.	d_2	d_3	l_1	Specifiche	Codice
200 - 280	40	88	51	MB0120-200280-Z2-CA40	30415229
280 - 360	40	88	51	MB0120-280360-Z2-CA40	30415230
360 - 440	40	88	61	MB0120-360440-Z2-CA40	30415231
440 - 520	40	88	61	MB0120-440520-Z2-CA40	30415232

Tempi di consegna su richiesta.

ModulBore – Testina per barenatura di precisione con modulo ponte

Utensile di barenatura per la finitura, versione rafforzata in alluminio, senza slitte e cartuccia

Ø 358 - 1.000 mm

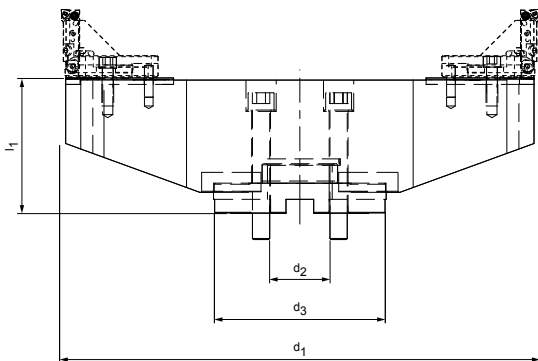

d_1 min. - max.	d_2	d_3	l_1	Specifiche	Codice
358 - 440	60	130	91	MB0130-358440-Z2-CA60	30415233
438 - 520	60	130	126	MB0130-438520-Z2-CA60	30415234
518 - 600	60	130	126	MB0130-518600-Z2-CA60	30415235
598 - 680	60	130	126	MB0130-598680-Z2-CA60	30415236
678 - 760	60	130	126	MB0130-678760-Z2-CA60	30415237
758 - 840	60	130	126	MB0130-758840-Z2-CA60	30415238
838 - 920	60	130	126	MB0130-838920-Z2-CA60	30415239
918 - 1.000	60	130	126	MB0130-918000-Z2-CA60	30415240

Tempi di consegna su richiesta.

Misure in mm.

ModulBore - Slitte per cartuccia per barenatura di precisione

Ø 200 - 1.000 mm

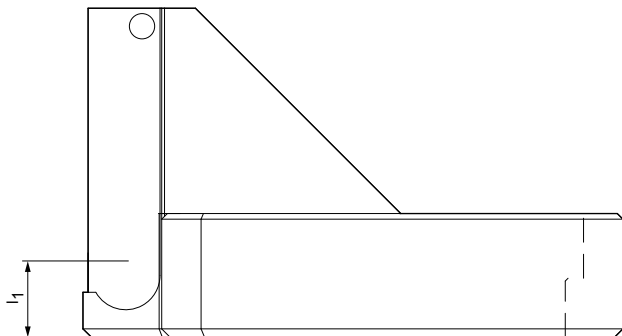

Per ø utensile d_1	l_1	Specifiche	Codice
200 - 1.000	13,1	SL-MBO150-2001000	30415311

Peso di bilanciamento in caso di lavorazione mandrino a un tagliente, codice 30522418.
Tempi di consegna su richiesta.

Esempio

Riepilogo sistema - Testina per barenatura di precisione con modulo ponte

Ø 200 - 1.000 mm

Adattatori

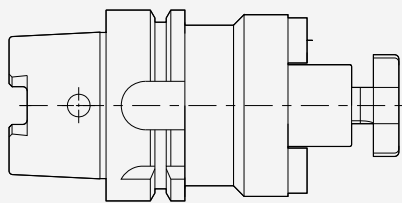

Modulo ponte

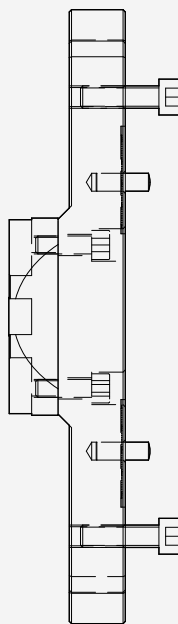

Slitte + cartuccia per barenatura di precisione + massa di compensazione

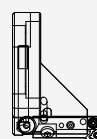
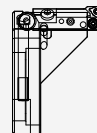

ModulBore – Cartuccia per barenatura di precisione

Ø 87 - 1.000 mm

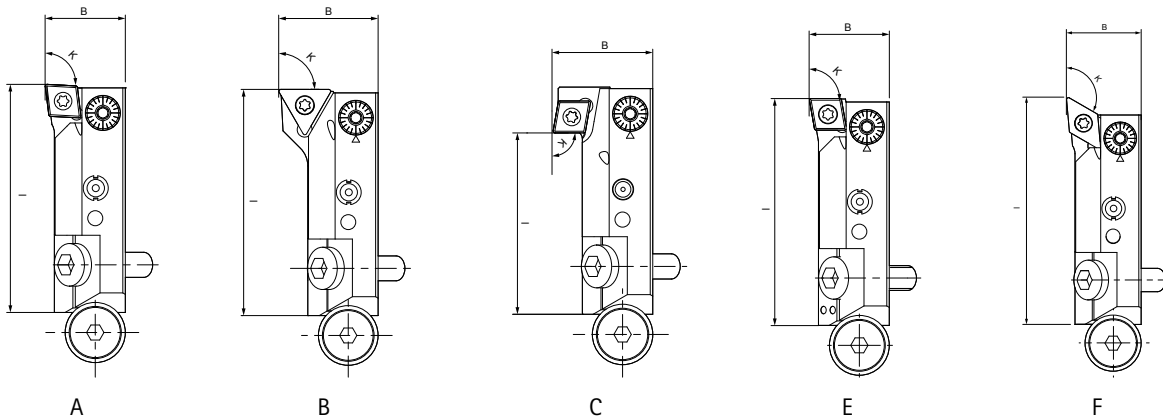

Tipo	l	B	K	Versione	Inserto a fissaggio meccanico	Specifiche	Codice
A	45,5	16	93°	destra	CC..0602	MBO501-R-093-16-CC_0602	10030384
A	45,5	16	93°	sinistra	CC..0602	MBO501-L-093-16-CC_0602	30415298
B	45,5	20	90°	destra	TC..1102	MBO501-R-090-20-TC_1102	30355664
B	45,5	20	90°	sinistra	TC..1102	MBO501-L-090-20-TC_1102	30353989
C	36	20	90°	indietro	CC..0602	MBO501-B-090-20-CC_0602	30415297
A	45,5	16	95°	destra	CC..0602	MBO501-R-095-16-CC_0602	10078197
A	45,5	16	95°	sinistra	CC..0602	MBO501-L-095-16-CC_0602	30415299
E	45,5	16	90°	destra	CC..0602	MBO501-R-090-16-CC_0602	10078198
E	45,5	16	90°	sinistra	CC..0602	MBO501-L-090-16-CC_0602	10078199

Con regolazione fine 10 µm | Corsa di regolazione riferita a valore B + 0,6 mm Ø
Tempi di consegna su richiesta.

Disponibile su richiesta

Tipo	l	B	k	Versione	Inserto a fissaggio meccanico	Specifiche	Codice
F	48,5	16	120° (5°)	sinistra	DC..0702	MBO501-L-120-16-DC_0702	30415305
F	45,8	16	120° (5°)	destra	DC..0702	MBO501-R-120-16-DC_0702	30415302
A	45,5	22	95°	sinistra	CC..09T3	MBO501-L-095-22-CC_09T3	30415304
A	45,5	22	95°	destra	CC..09T3	MBO501-R-095-22-CC_09T3	30415301

ModulBore-Plus – Cartuccia per barenatura di precisione

Tipo	l	B	K	Versione	Inserto a fissaggio meccanico	Specifiche	Codice
A	45,5	16	93°	destra	CC..0602	MBO511-R-093-16-CC_0602	30415307
A	45,5	16	95°	destra	CC..0602	MBO511-R-095-16-CC_0602	30415308
A	45,5	16	90°	destra	CC..0602	MBO511-R-090-16-CC_0602	30415306

Con regolazione fine 2 µm | Corsa di regolazione riferita a valore B + 0,5 mm Ø
Tempi di consegna su richiesta.

Adattatore MBS

Codolo conico SK secondo ISO 7388-1 forma AD/AF

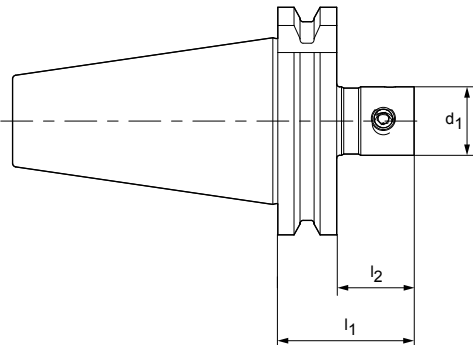

SK	d ₁ Dimensione MBS	l ₁	l ₂	Specifiche	Codice
40	18,5	60	40	MBS101-N-185-040-SK040-S	30415332
40	24,5	60	40	MBS101-N-245-060-SK040-S	30415333
40	32	60	40	MBS101-N-320-060-SK040-S	30415334
40	42	60	40	MBS101-N-420-060-SK040-S	30415335
40	55	65	45	MBS101-N-550-065-SK040-S	30415336
50	18,5	40	20	MBS101-N-185-040-SK050-S	30415337
50	24,5	40	20	MBS101-N-245-040-SK050-S	30415338
50	32	60	40	MBS101-N-320-060-SK050-S	30415339
50	42	60	40	MBS101-N-420-060-SK050-S	30415340
50	55	60	40	MBS101-N-550-060-SK050-S	30415341
50	72	65	45	MBS101-N-720-065-SK050-S	30415342

Tempi di consegna su richiesta.

Adattatori MBS

Codolo BT secondo ISO 7388-2 forma J (JIS B 6339)

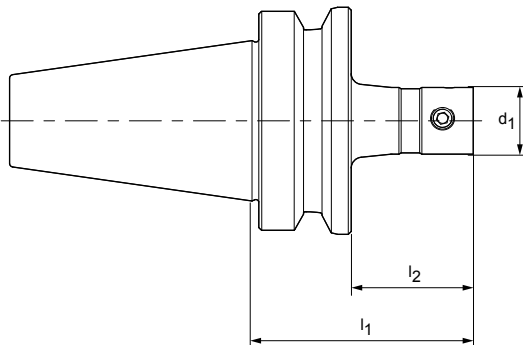

BT	d ₁ Dimensione MBS	l ₁	l ₂	Specifiche	Codice
40	18,5	40	33	MBS101-N-185-060-BT040-S	30415344
40	24,5	40	33	MBS101-N-245-060-BT040-S	30415345
40	32	60	33	MBS101-N-320-060-BT040-S	30415346
40	42	60	33	MBS101-N-420-060-BT040-S	30415347
40	55	60	33	MBS101-N-550-065-BT040-S	30415348
50	18,5	40	-	MBS101-N-185-040-BT050-S	30415349
50	24,5	40	-	MBS101-N-245-040-BT050-S	30415350
50	32	60	22	MBS101-N-320-060-BT050-S	30415351
50	42	60	22	MBS101-N-420-060-BT050-S	30415352
50	55	60	27	MBS101-N-550-065-BT050-S	30415353
50	72	60	32	MBS101-N-720-070-BT050-S	30415354

Tempi di consegna su richiesta.

Adattatori MBS

Codolo conico cavo HSK-A secondo DIN 69893-1

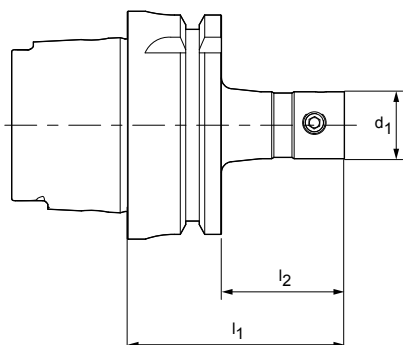

HSK-A	d ₁ Dimensione MBS	l ₁	l ₂	Specifiche	Codice
63	18,5	60	34	MBS101-N-185-060-HSK-A063-S	30415367
63	24,5	60	34	MBS101-N-245-060-HSK-A063-S	30415368
63	32	60	34	MBS101-N-320-060-HSK-A063-S	30415369
63	42	70	44	MBS101-N-420-070-HSK-A063-S	30415370
63	55	80	54	MBS101-N-550-080-HSK-A063-S	30415371
63	72	95	69	MBS101-N-720-095-HSK-A063-S	30415372
100	32	70	41	MBS101-N-320-070-HSK-A100-S	30415373
100	42	80	51	MBS101-N-420-080-HSK-A100-S	30415374
100	55	90	61	MBS101-N-420-550-HSK-A100-S	30415375
100	72	105	76	MBS101-N-720-105-HSK-A100-S	30415376

Tempi di consegna su richiesta.

Prolunghe MBS

MBS su MBS

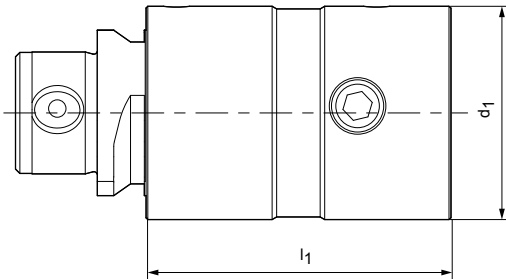

d ₁ Dimensione MBS	l ₁	Specifiche	Codice
18,5	30	MBS185-MBS185-030-01	30415380
18,5	35	MBS185-MBS185-035-01	30415381
24,5	30	MBS245-MBS245-030-01	30415382
24,5	35	MBS245-MBS245-035-01	30415383
24,5	45	MBS245-MBS245-045-01	30415384
32	40	MBS320-MBS320-040-01	30415385
32	50	MBS320-MBS320-050-01	30415386
32	60	MBS320-MBS320-060-01	30415387
42	50	MBS420-MBS420-050-01	30415388
42	60	MBS420-MBS420-060-01	30415389
42	80	MBS420-MBS420-080-01	30415390
55	70	MBS550-MBS550-070-01	30415391
55	90	MBS550-MBS550-090-01	30415392
55	105	MBS550-MBS550-105-01	30415393
72	75	MBS720-MBS720-075-01	30415394
72	100	MBS720-MBS720-100-01	30415395
72	135	MBS720-MBS720-135-01	30415396

Tempi di consegna su richiesta.

Riduttori MBS

MBS su MBS

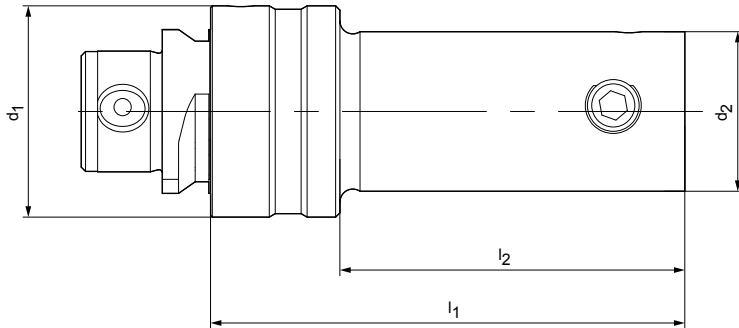

d_1 Dimensione MBS	d_2 Dimensione MBS	l_1	l_2	Specifiche	Codice
24,5	18,5	30	15	MBS245-MBS185-030-01	30415399
32	18,5	30	51	MBS320-MBS185-030-01	30415401
32	24,5	40	25	MBS320-MBS245-040-01	30415403
42	18,5	35	15	MBS420-MBS185-035-01	30415405
42	24,5	45	25	MBS420-MBS245-045-01	30415407
42	32	45	25	MBS420-MBS320-045-01	30415409
55	18,5	40	15	MBS550-MBS185-040-01	30415411
55	24,5	50	25	MBS550-MBS245-050-01	30415413
55	32	50	25	MBS550-MBS320-050-01	30415415
55	42	55	30	MBS550-MBS420-055-01	30415417
72	42	60	30	MBS720-MBS420-060-01	30415419
72	55	60	30	MBS720-MBS550-060-01	30415420

Tempi di consegna su richiesta.

ModulBore - Mandrini a innesto

Con attacco a croce e sistema di foratura modulare MBS

Codolo MBS

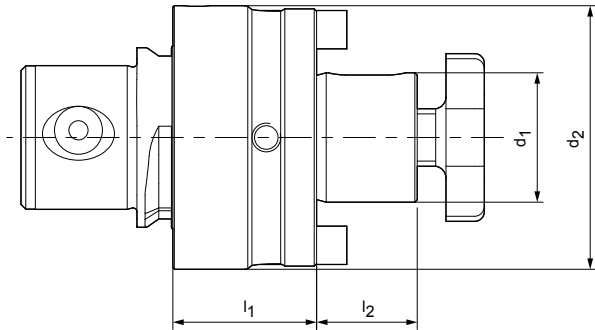

Dimensione MBS	d ₁	d ₂	l ₁	l ₂	Specifiche	Codice
MBS420	27	42	30	21	MCA-MBS420-27-30-1-0-W	30415312
MBS550	27	55	30	21	MCA-MBS550-27-30-1-0-W	30415313
MBS720	40	72	35	27	MCA-MBS720-40-35-1-0-W	30415314

Tempi di consegna su richiesta.

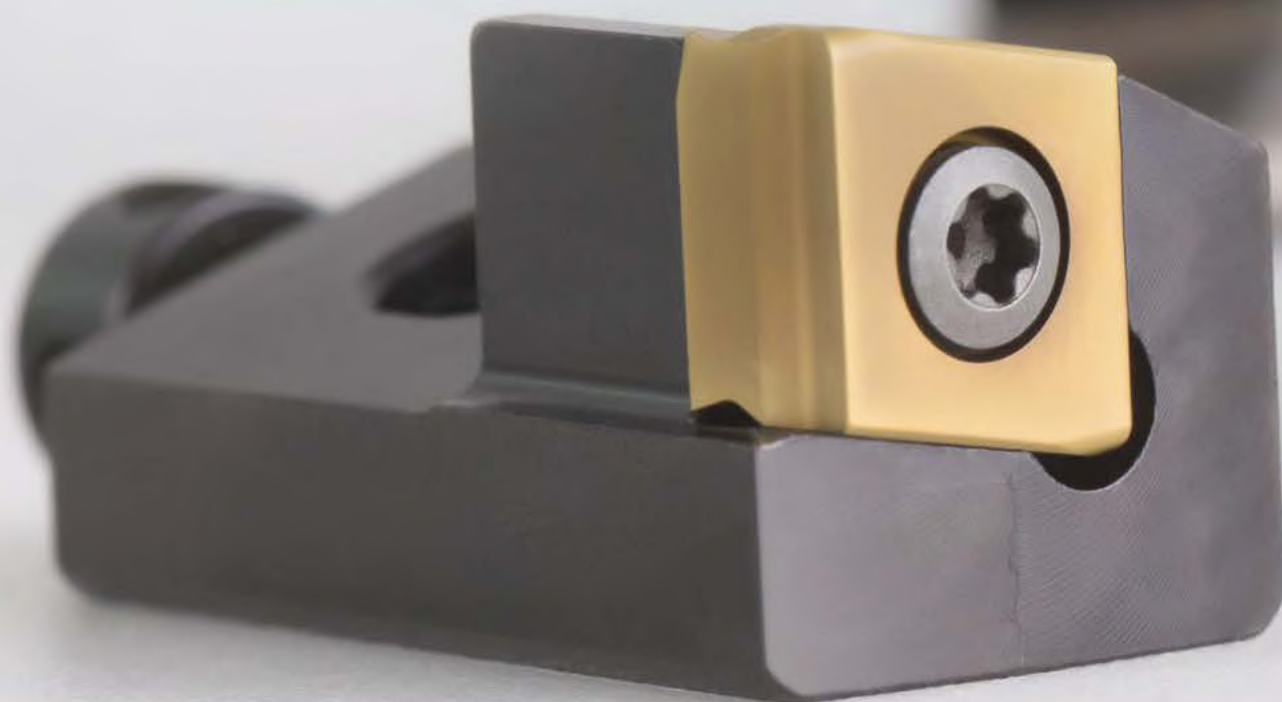

CARTUCCE

Le cartucce non solo assicurano un'ampia corsa di regolazione ma offrono anche numerose possibilità per svariate applicazioni e una sostituzione semplice e rapida. Vengono impiegate sia per lavorazioni esterne che interne. In caso di modifiche, ad esempio degli angoli dello smusso, o riparazione, possono essere sostituite senza fatica.

L'assortimento di cartucce MAPAL copre la maggior parte delle varianti costruttive di montaggio. Oltre alle cartucce ISO standardizzate, è disponibile tutta una serie di cartucce compatte per inserti a fissaggio meccanico di tipo radiale e tangenziale. Grazie a lunghezze costruttive ridotte, offrono ancora più spazio per l'inserimento di strumenti personalizzati.

Su richiesta MAPAL fornisce anche cartucce e cartucce compatte in versioni speciali.

Cartucce

Codice di denominazione	644
Cartuccia ISO	646
Cartuccia compatta	650
Cartuccia compatta per inserti a fissaggio tangenziale	656
Accessori	660

Confronto dimensioni tra cartuccia compatta MAPAL e cartuccia ISO

Esempio: Dimensione inserto 09

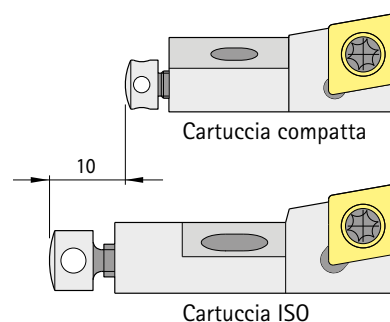

Codice di denominazione Cartuccia e cartuccia compatta

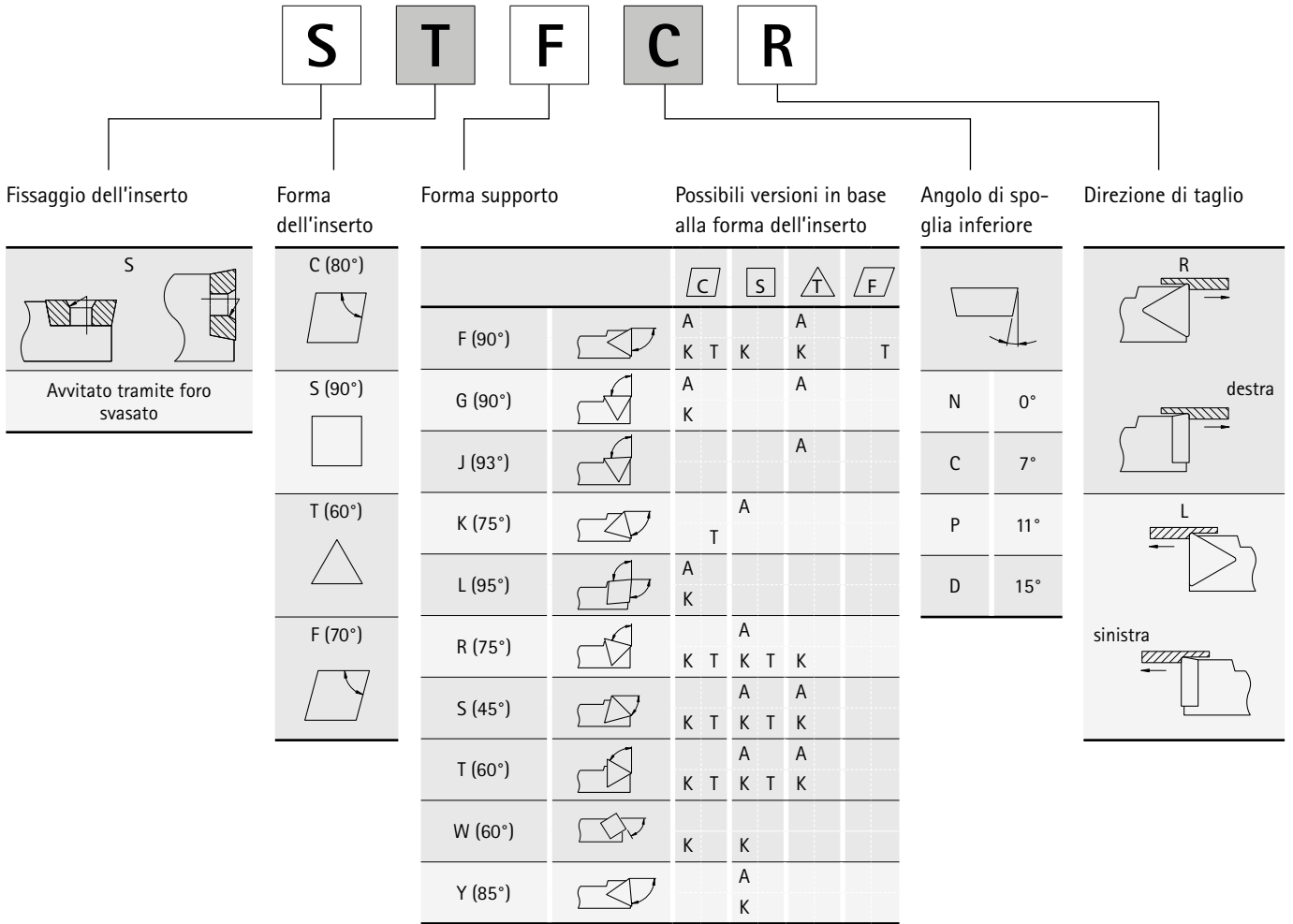

A = Cartuccia
 K = Cartuccia compatta
 T = Cartuccia compatta per inserti a fissaggio tangenziale

Cartuccia compatta con angolo speciale Indicazione della forma del supporto direttamente tramite l'angolo di regolazione

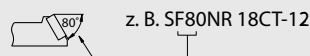
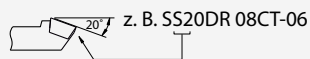

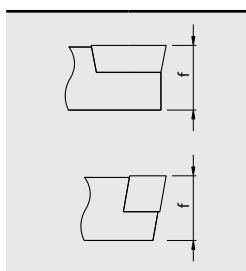
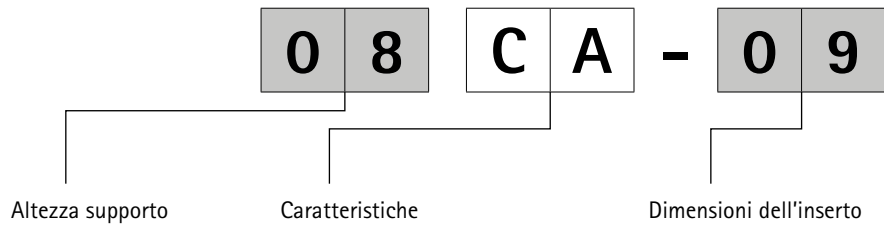

Indicazioni sull'altezza

Numero identificativo	[mm]
06	6,0
08	8,0
10	10,0
12	12,0
14	14,0
18	18,0

Prima cifra	Significato
C	Cartuccia

Seconda cifra	Significato
A	Cartuccia secondo DIN 4985
K	Cartuccia compatta analoga a DIN 4985
T	Cartuccia compatta analoga a DIN 4985 per inserti a fissaggio tangenziale

Circonferenza inserita				
	C	S	T	F
d [mm]	05	-	09	-
5,56	05	-	09	-
6,35	06	06	11	06
9,525	09	09	16	09
12,7	12	12	-	12

Cartuccia ISO

Forma F, G

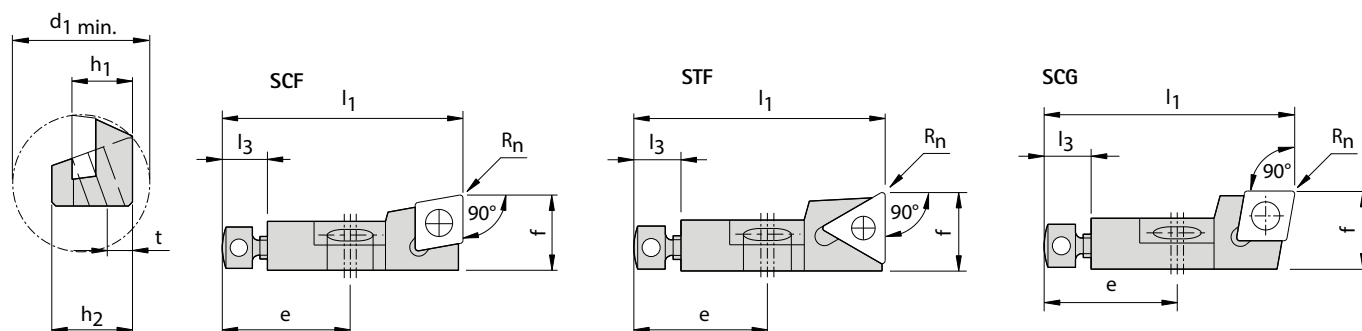

Disegni in versione destra, esempio SCFCR.

Serie selezionata per il magazzino

	Specifiche	Inserto corrispondente	Dimensioni									Gruppo accessori *	Codice
			h_1	f (riferito a R_n)	R_n	l_1	e	l_3	h_2	t	$d_1 \text{ min.}$		
SCF...	SCFCR 08CA-06	CC_0602__	8	10	0,4	32	17	6	9,5	4,5	25	3	30011050
	SCFCL 08CA-06	CC_0602__	8	10	0,4	32	17	6	9,5	4,5	25	3	30011051
	SCFPR 08CA-06	CP_0602__	8	10	0,4	32	17	6	9,5	4,5	25	3	30011052
	SCFPL 08CA-06	CP_0602__	8	10	0,4	32	17	6	9,5	4,5	25	3	30011053
	SCFCR 10CA-09	CC_09T3__	10	14	0,8	50	20	8	13	5	40	5	30011054
	SCFCR 12CA-12	CC_1204__	12	20	0,8	55	20	8	17	6	50	1	30011056
	SCFCL 12CA-12	CC_1204__	12	20	0,8	55	20	8	17	6	50	1	30011057
STF...	STFCR 08CA-09	TC_0902__	8	10	0,4	32	17	6	9,5	4,5	25	2	30011058
	STFCR 10CA-11-02	TC_1102__	10	14	0,4	50	20	8	13	5	40	4	30011060
	STFCR 12CA-16	TC_16T3__	12	20	0,8	55	20	8	17	6	50	6	30011062
SCG...	SCGCR 08CA-06	CC_0602__	8	10	0,4	32	17	6	9,5	4,5	25	3	30011064
	SCGCL 08CA-06	CC_0602__	8	10	0,4	32	17	6	9,5	4,5	25	3	30011065
	SCGCR 10CA-09	CC_09T3__	10	14	0,8	50	20	8	13	5	40	5	30011068

* vedere pagine 660-661

Altre forme del tagliente, dimensioni e angoli di regolazione su richiesta.

Fornitura: Cartuccia con componenti integrati. Inserti a fissaggio meccanico e componenti accessori vanno ordinati separatamente.

Misure in mm.

Cartuccia ISO

Forma J, K, L

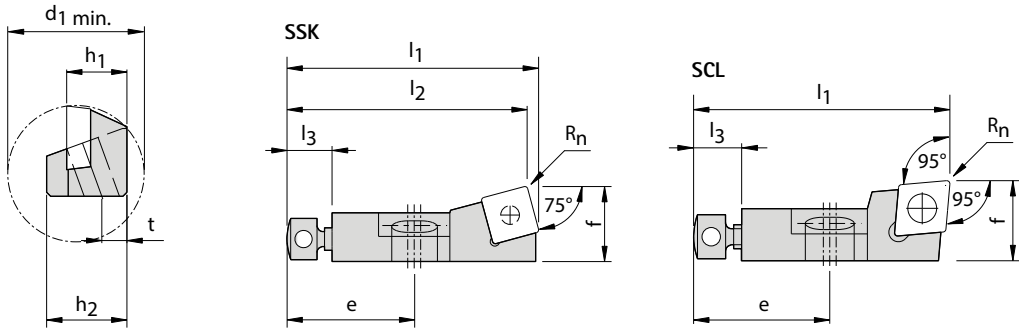

Disegni in versione destra, esempio STJCR.

Serie selezionata per il magazzino

	Specifiche	Inserto corrispondente	Dimensioni										Gruppo accessori *	Codice
			h_1	f (riferito a R_n)	R_n	l_1	l_2	e	l_3	h_2	t	d_1 min.		
SSK...	SSKCR 10CA-09	SC_09T3__	10	14	0,8	52,2	50	20	8	13	5	40	5	30011086
	SSKCL 10CA-09	SC_09T3__	10	14	0,8	52,2	50	20	8	13	5	40	5	30011087
	SSKCR 12CA-12	SC_1204__	12	20	0,8	58,1	55	20	8	17	6	50	1	30011088
SCL...	SCLCR 10CA-09	CC_09T3__	10	14	0,8	50	-	20	8	13	5	40	5	30011094
	SCLCL 10CA-09	CC_09T3__	10	14	0,8	50	-	20	8	13	5	40	5	30011095
	SCLCL 12CA-12	CC_1204__	12	20	0,8	55	-	20	8	17	6	50	1	30011097

* vedere pagine 660-661

Altre forme del tagliente, dimensioni e angoli di regolazione su richiesta.

Fornitura: Cartuccia con componenti integrati. Inserti a fissaggio meccanico e componenti accessori vanno ordinati separatamente.

Misure in mm.

Cartuccia ISO

Forma R, S

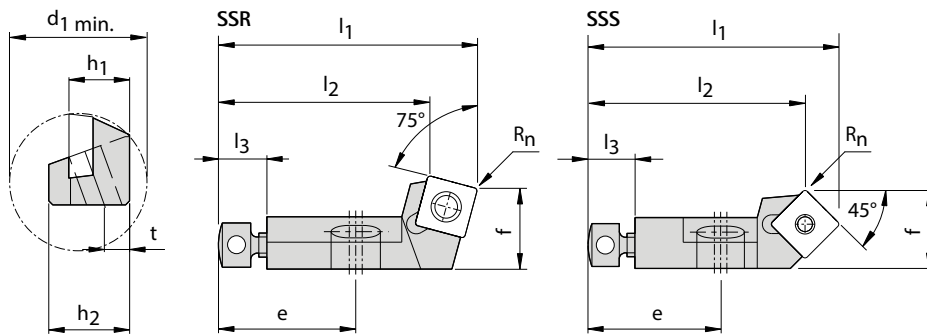

Disegni in versione destra, esempio SSRCR.

Serie selezionata per il magazzino

	Specifiche	Inserto corrispondente	Dimensioni										Gruppo accessori *	Codice
			h_1	f (riferito a R_n)	R_n	l_1	l_2	e	l_3	h_2	t	$d_1 \text{ min.}$		
SSR...	SSRCR 08CA-06	SC_0602__	8	10	0,4	32	26,4	17	6	9,5	4,5	25	3	30011098
	SSRCR 10CA-09	SC_09T3__	10	14	0,8	50	41,3	20	8	13	5	40	5	30011100
	SSRCR 12CA-12	SC_1204__	12	20	0,8	55	43,5	20	8	17	6	50	1	30011102
	SSRCL 12CA-12	SC_1204__	12	20	0,8	55	43,5	20	8	17	6	50	1	30011103
SSS...	SSSCR 08CA-06	SC_0602__	8	10	0,4	32,4	28	17	6	9,5	4,5	25	3	30011104
	SSSCL 08CA-06	SC_0602__	8	10	0,4	32,4	28	17	6	9,5	4,5	25	3	30011105
	SSSCR 10CA-09	SC_09T3__	10	14	0,8	50,1	44	20	8	13	5	40	5	30011106

* vedere pagine 660-661

Altre forme del tagliente, dimensioni e angoli di regolazione su richiesta.

Fornitura: Cartuccia con componenti integrati. Inserti a fissaggio meccanico e componenti accessori vanno ordinati separatamente.

Misure in mm.

Cartuccia ISO

Forma T, Y

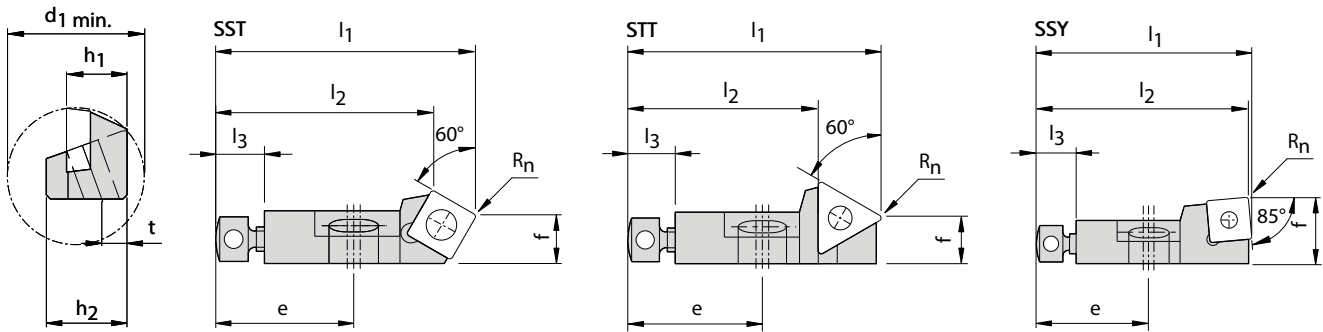

Disegni in versione destra, esempio SSTCR.

Serie selezionata per il magazzino

	Specifiche	Inserto corrispondente	Dimensioni										Gruppo accessori *	Codice
			h_1	f	R_n	l_1	l_2	e	l_3	h_2	t	$d_1 \text{ min.}$		
SST...	SSTCR 10CA-09	SC_09T3__	10	13,3	0,8	50	40,6	20	8	13	5	40	5	30011118
	SSTCL 10CA-09	SC_09T3__	10	13,3	0,8	50	40,6	20	8	13	5	40	5	30011119
	SSTCR 12CA-12	SC_1204__	12	18,9	0,8	55	44,8	20	8	17	6	50	1	30011120
STT...	STTCR 08CA-09	TC_0902__	8	10,3	0,4	32	24,6	17	6	9,5	4,5	25	2	30011122
	STTCR 10CA-11-02	TC_1102__	10	14	0,4	50	41,4	20	8	13	5	40	4	30011124
SSY...	SSYCR 10CA-09	SC_09T3__	10	14	0,8	50,8	50	20	8	13	5	40	5	30011130
	SSYCR 12CA-12	SC_1204__	12	20	0,8	56	55	20	8	17	6	50	1	30011132

* vedere pagine 660-661

Altre forme del tagliente, dimensioni e angoli di regolazione su richiesta.

Fornitura: Cartuccia con componenti integrati. Inserti a fissaggio meccanico e componenti accessori vanno ordinati separatamente.

Misure in mm.

Cartuccia compatta

Forma F

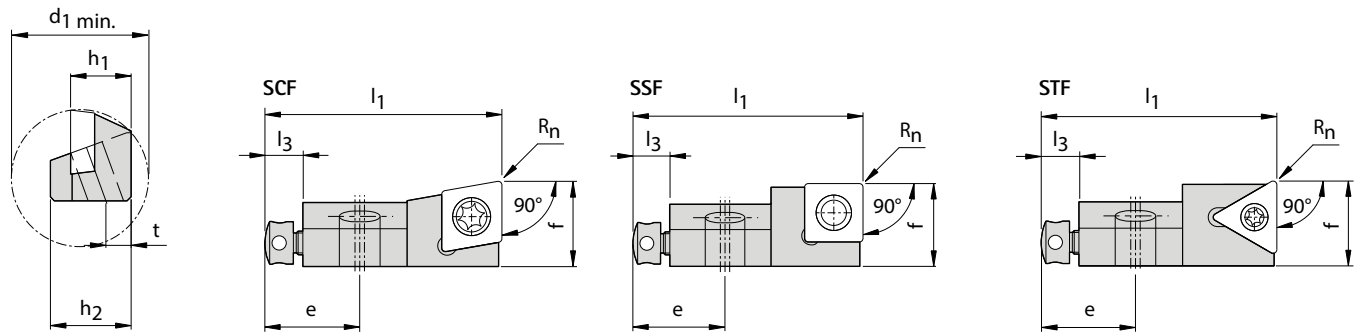

Disegni in versione destra, esempio SCFCR.

Serie selezionata per il magazzino

	Specifiche	Inserto corrispondente	Dimensioni									Gruppo accessori *	Codice
			h_1	f (riferito a R_n)	R_n	l_1	e	l_3	h_2	t	$d_1 \text{ min.}$		
SCF...	SCFCR 06CK-06 V1	CC_0602_	6	8,5	0,4	25	11	5	6	2,5	18	9	30011134
	SCFCL 06CK-06 V1	CC_0602_	6	8,5	0,4	25	11	5	6	2,5	18	9	30011135
	SCFCR 06CK-06 V2	CC_0602_	6	9,7	0,4	25	11	5	6	2,5	18	9	30011136
	SCFCR 10CK-09	CC_09T3_	10	14	0,8	40	17	8	15	5	33	14	30011138
	SCFCL 10CK-09	CC_09T3_	10	14	0,8	40	17	8	15	5	33	14	30011139
	SCFCR 12CK-12	CC_1204_	12	18	0,8	50	20	8	16	5	37	7	30011140
	SCFCL 12CK-12	CC_1204_	12	18	0,8	50	20	8	16	5	37	7	30011141
SSF...	SSFPR 08CK-06	SP_0603_	8	10	0,4	32	17	5	10	4,5	24	13	30011142
	SSFPR 10CK-09	SC_09T3_	10	14	0,8	44	17	8	15	5	33	16	30011144
	SSFPR 12CK-12	SC_1204_	12	18	0,8	50	20	8	16	5	37	7	30011146
	SSFCL 12CK-12	SC_1204_	12	18	0,8	50	20	8	16	5	37	7	30011147
STF...	STFCR 06CK-09	TC_0902_	6	10	0,4	25	11	5	6	2,5	18	17	30011148
	STFCR 10CK-11	TC_1102_	10	14	0,4	40	17	8	15	5	33	11	30011150
	STFCR 12CK-16	TC_16T3_	12	18	0,8	50	20	8	16	5	37	12	30011152

* vedere pagine 660-661

Altre forme del tagliente, dimensioni e angoli di regolazione su richiesta.

Fornitura: Cartuccia con componenti integrati. Inserti a fissaggio meccanico e componenti accessori vanno ordinati separatamente.

Misure in mm.

Cartuccia compatta

Forma G, L

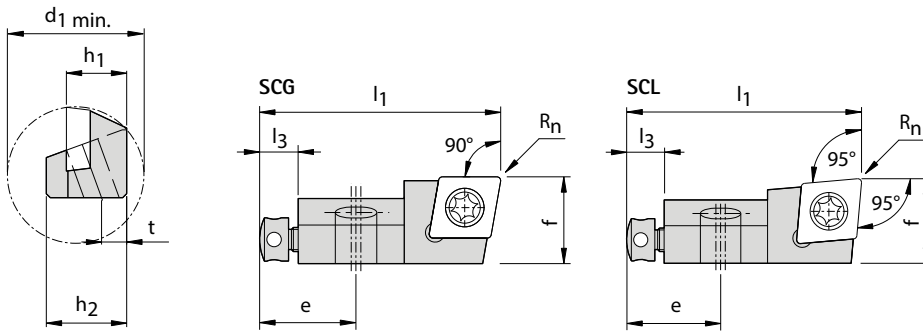

Disegni in versione destra, esempio SCGCR.

Serie selezionata per il magazzino

	Specifiche	Inserto corrispondente	Dimensioni									Gruppo accessori *	Codice
			h_1	f (riferito a R_n)	R_n	l_1	e	l_3	h_2	t	$d_1 \text{ min.}$		
SCG...	SCGCR 06CK-06 V1	CC_0602__	6	8,5	0,4	25	11	5	6	2,5	18	10	30011154
	SCGCL 06CK-06 V1	CC_0602__	6	8,5	0,4	25	11	5	6	2,5	18	10	30011155
	SCGCR 10CK-09	CC_09T3__	10	14	0,8	40	17	8	15	5	33	15	30011158
	SCGCL 10CK-09	CC_09T3__	10	14	0,8	40	17	8	15	5	33	15	30011159
	SCGCR 12CK-12	CC_1204__	12	18	0,8	50	20	8	16	5	37	8	30011160
	SCGCL 12CK-12	CC_1204__	12	18	0,8	50	20	8	16	5	37	8	30011161
SCL...	SCLCR 06CK-06 V1	CC_0602__	6	8,5	0,4	25	11	5	6	2,5	18	10	30011162
	SCLCL 06CK-06 V1	CC_0602__	6	8,5	0,4	25	11	5	6	2,5	18	10	30011163
	SCLCR 06CK-06 V2	CC_0602__	6	9,7	0,4	25	11	5	6	2,5	18	10	30011164
	SCLCL 06CK-06 V2	CC_0602__	6	9,7	0,4	25	11	5	6	2,5	18	10	30011165
	SCLCR 10CK-09	CC_09T3__	10	14	0,8	40	17	8	15	5	33	15	30011166
	SCLCL 10CK-09	CC_09T3__	10	14	0,8	40	17	8	15	5	33	15	30011167
	SCLCR 12CK-12	CC_1204__	12	18	0,8	50	20	8	16	5	37	7	30011168
	SCLCL 12CK-12	CC_1204__	12	18	0,8	50	20	8	16	5	37	7	30011169

* vedere pagine 660-661

Altre forme del tagliente, dimensioni e angoli di regolazione su richiesta.

Fornitura: Cartuccia con componenti integrati. Inserti a fissaggio meccanico e componenti accessori vanno ordinati separatamente.

Misure in mm.

Cartuccia compatta

Forma R

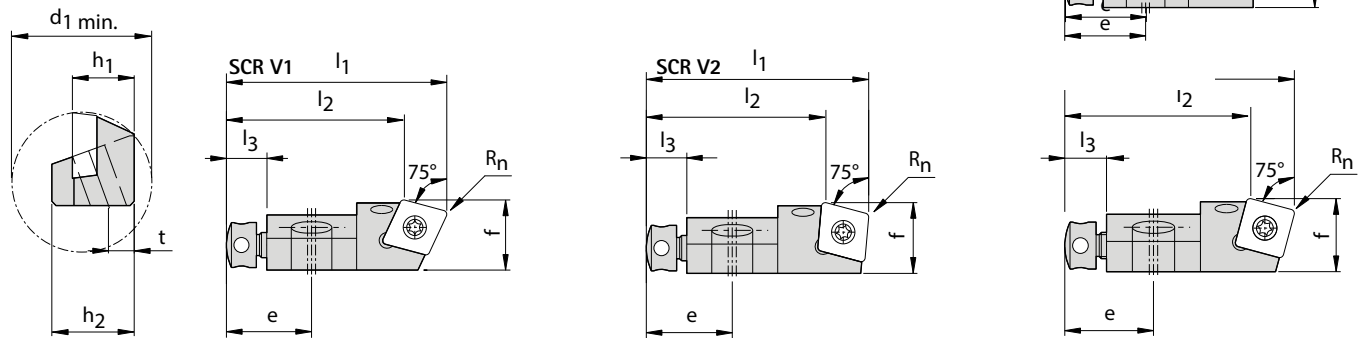

Disegni in versione destra, esempio SCRCR.

Serie selezionata per il magazzino

	Specifiche	Inserto corrispondente	Dimensioni										Gruppo accessori *	Codice
			h_1	f (riferito a R_n)	R_n	l_1	l_2	e	l_3	h_2	t	d_1 min.		
SCR...V1	SCRCR 06CK-06 V1	CC_0602__	6	9,7	0,4	25	19,2	11	5	6	2,5	18	9	30011170
	SCRCR 10CK-09 V1	CC_09T3__	10	14	0,8	44	35,5	17	8	15	5	33	14	30011172
SCR...V2	SCRCR 06CK-06 V2	CC_0602__	6	10	0,4	25	19,2	11	5	6	2,5	18	9	30011174
	SCRCR 10CK-09 V2	CC_09T3__	10	14	0,8	44	35,5	17	8	15	5	33	16	30011176
SSR...	SSRPR 08CK-06	SP_0603__	8	10	0,4	32	26,3	17	5	10	4,5	24	13	30011178
	SSRCR 10CK-09	SC_09T3__	10	14	0,8	44	35,7	17	8	15	5	33	16	30011180
	SSRCL 10CK-09	SC_09T3__	10	14	0,8	44	35,7	17	8	15	5	33	16	30011181
	SSRCR 12CK-12	SC_1204__	12	18	0,8	50	38,6	20	8	16	5	37	7	30011182
STR...	STRCR 10CK-11	TC_1102__	10	14	0,4	40	30,4	17	8	15	5	33	11	30011186
	STRCR 12CK-16	TC_16T3__	12	18	0,8	50	36,1	20	8	16	5	37	12	30011188

* vedere pagine 660-661

Altre forme del tagliente, dimensioni e angoli di regolazione su richiesta.

Fornitura: Cartuccia con componenti integrati. Inserti a fissaggio meccanico e componenti accessori vanno ordinati separatamente.

Misure in mm.

Cartuccia compatta

Forma S

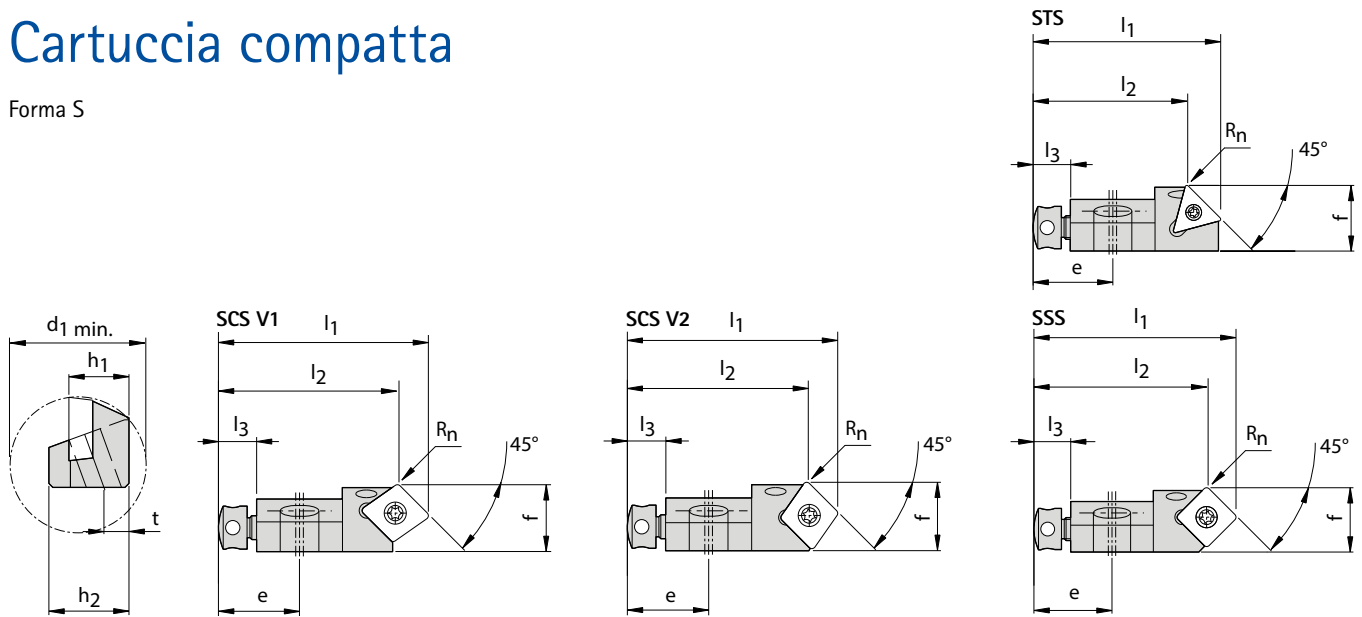

Disegni in versione destra, esempio SCSCR.

Serie selezionata per il magazzino

	Specifiche	Inserto corrispondente	Dimensioni										Gruppo accessori *	Codice
			h_1	f (riferito a R_n)	R_n	l_1	l_2	e	l_3	h_2	t	$d_1 \text{ min.}$		
SCS...V1	SCSCR 06CK-06 V1	CC_0602__	6	9,7	0,4	25	20,8	11	5	6	2,5	18	9	30011190
	SCSCR 10CK-09 V1	CC_09T3__	10	14	0,8	44	37,8	17	8	15	5	33	14	30011192
SCS...V2	SCSCR 06CK-06 V2	CC_0602__	6	10	0,4	25	20,8	11	5	6	2,5	18	9	30011194
	SCSCR 10CK-09 V2	CC_09T3__	10	14,3	0,8	44	37,8	17	8	15	5	33	14	30011196
SSS...	SSSPR 08CK-06	SP_0603__	8	10	0,4	32	27,8	17	5	10	4,5	24	13	30011198
	SSSPL 08CK-06	SP_0603__	8	10	0,4	32	27,8	17	5	10	4,5	24	13	30011199
	SSSCR 10CK-09	SC_09T3__	10	14	0,8	44	37,9	17	8	15	5	33	14	30011200
	SSSCL 10CK-09	SC_09T3__	10	14	0,8	44	37,9	17	8	15	5	33	14	30011201
	SSSCR 12CK-12	SC_1204__	12	18	0,8	50	41,7	20	8	16	5	37	7	30011202
STS...	STSCR 06CK-09	TC_0902__	6	10	0,4	25	18,9	11	5	6	2,5	18	17	30011204
	STSCR 10CK-11	TC_1102__	10	14	0,4	40	33	17	8	15	5	33	11	30011206

* vedere pagine 660-661

Altre forme del tagliente, dimensioni e angoli di regolazione su richiesta.

Fornitura: Cartuccia con componenti integrati. Inserti a fissaggio meccanico e componenti accessori vanno ordinati separatamente.

Misure in mm.

Portainsero compatto

Forma T

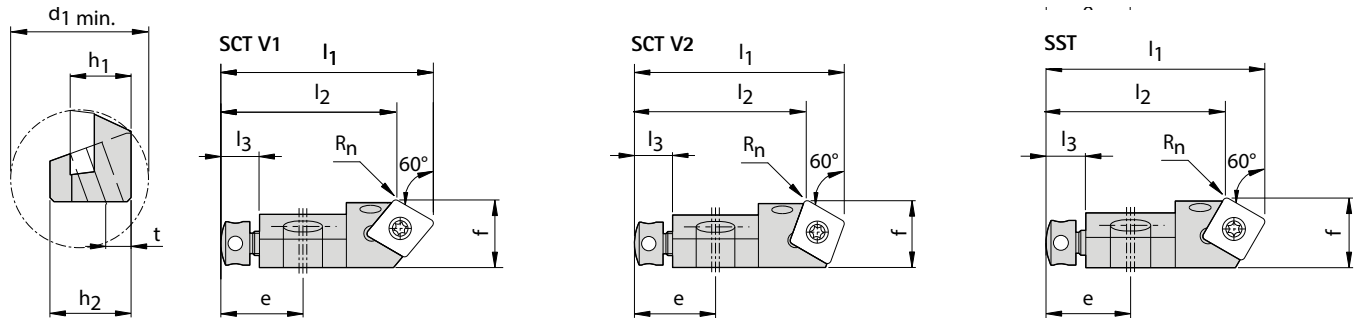

Disegni in versione destra, esempio SCTCR.

Serie selezionata per il magazzino

	Specifiche	Inserto corrispondente	Dimensioni										Gruppo accessori*	Codice
			h_1	f	R_n	l_1	l_2	e	l_3	h_2	t	$d_1 \text{ min.}$		
SCT...V1	SCTCR 06CK-06 V1	CC_0602__	6	9,7	0,4	25	19,8	11	5	6	2,5	18	9	30011210
	SCTCR 10CK-09 V1	CC_09T3__	10	14	0,8	44	36,5	17	8	15	5	33	14	30011212
SCT...V2	SCTCR 06CK-06 V2	CC_0602__	6	10	0,4	25	19,8	11	5	6	2,5	18	9	30011214
	SCTCR 10CK-09 V2	CC_09T3__	10	14	0,8	44	36,5	17	8	15	5	33	16	30011216
SST...	SSTPR 08CK-06	SP_0603__	8	10	0,4	32	26,9	17	5	10	4,5	24	13	30011218
	SSTCR 10CK-09	SC_09T3__	10	14	0,8	44	36,6	17	8	15	5	33	14	30011220
	SSTCR 12CK-12	SC_1204__	12	18	0,8	50	39,8	20	8	16	5	37	7	30011222
STTCR...	STTCR 06CK-09	TC_0902__	6	10	0,4	25	17,6	11	5	6	2,5	18	17	30011224
	STTCR 10CK-11	TC_1102__	10	14	0,4	40	31,4	17	8	15	5	33	11	30011226
	STTCR 12CK-16	TC_16T3__	12	18	0,8	50	37,5	20	8	16	5	37	12	30011228

* vedere pagine 660-661

Altre forme del tagliente, dimensioni e angoli di regolazione su richiesta.

Fornitura: Cartuccia con componenti integrati. Inserti a fissaggio meccanico e componenti accessori vanno ordinati separatamente.

Misure in mm.

Cartuccia compatta

Forma W, Y

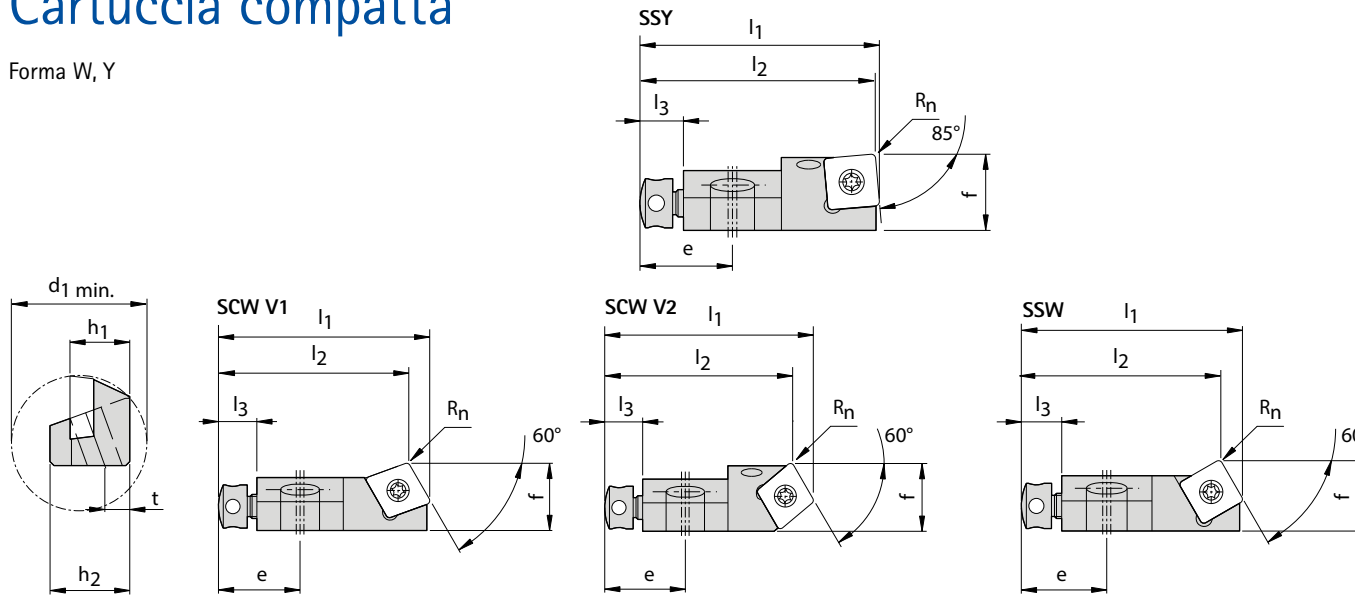

Disegni in versione destra, esempio SCWCR.

Serie selezionata per il magazzino

	Specifiche	Inserto corrispondente	Dimensioni										Gruppo accessori *	Codice
			h_1	f (riferito a R_n)	R_n	l_1	l_2	e	l_3	h_2	t	d_1 min.		
SCW...V1	SCWCR 06CK-06 V1	CC__0602__	6	9,7	0,4	25	22	11	5	6	2,5	18	9	30011230
	SCWCR 10CK-09 V1	CC__09T3__	10	14	0,8	44	39,6	17	8	15	5	33	16	30011232
SCW...V2	SCWCL 06CK-06 V2	CC__0602__	6	10	0,4	25	22	11	5	6	2,5	18	9	30011235
SSW...	SSWPR 08CK-06	SP__0603__	8	10	0,4	32	29,1	17	5	10	4,5	24	13	30011238
	SSWCL 10CK-09	SC__09T3__	10	14	0,8	44	39,7	17	8	15	5	33	16	30011241
	SSWCR 12CK-12	SC__1204__	12	18	0,8	50	44,1	20	8	16	5	37	7	30011242
	SSWCL 12CK-12	SC__1204__	12	18	0,8	50	44,1	20	8	16	5	37	7	30011243
SSY...	SSYPR 08CK-06	SP__0603__	8	10	0,4	32	31,5	17	5	10	4,5	24	13	30011250
	SSYCR 10CK-09	SC__09T3__	10	14	0,8	44	43,2	17	8	15	5	33	16	30011252
	SSYCL 10CK-09	SC__09T3__	10	14	0,8	44	43,2	17	8	15	5	33	16	30011253
	SSYCR 12CK-12	SC__1204__	12	18	0,8	50	49	20	8	16	5	37	7	30011254

* vedere pagine 660-661

Altre forme del tagliente, dimensioni e angoli di regolazione su richiesta.

Fornitura: Cartuccia con componenti integrati. Inserti a fissaggio meccanico e componenti accessori vanno ordinati separatamente.

Misure in mm.

Cartuccia compatta per inserti a fissaggio tangenziale

Forma F

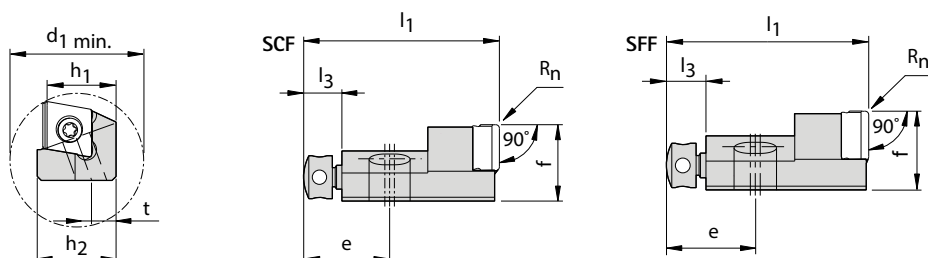

Disegni in versione destra, esempio SCFNR.

Serie selezionata per il magazzino

	Specifiche	Inserto corrispondente	Dimensioni										Gruppo accessori *	Codice
			h_1	f (riferito a R_n)	R_n	l_1	l_2	e	l_3	h_2	t	d_1 min.		
SCF...	SCFNR 10CT-06	CTHQ0604__	10	11	0,8	29	-	12	5	10,5	5	40	22	30305015
	SCFNR 14CT-09	CTHQ0905__	14	16	0,8	41	-	18	8	16	7	65	24	30305018
	SCFNR 18CT-12	CTHQ1206__	18	22	0,8	43	-	18	8	20	7	75	26	30305020
	SCFDR 10 CT-06	CTHD0603__	10	11	0,8	29	-	12	5	10,5	5	40	22	30552260
	SCFDR 14 CT-09	CTHD09T3__	14	16	0,8	41	-	18	8	16	7	65	20	30552263
	SCFDR 18 CT-12	CTHD1204__	18	22	0,8	43	-	18	8	20	7	75	18	30552264
SFF...	SFFNR 10CT-06	FTHQ0604__	10	11	0,8	29	-	12	5	10,5	5	35	22	30305022
	SFFNR 14CT-09	FTHQ0905__	14	16	0,8	41	-	18	8	16	7	44	24	30305024
	SFFNR 18CT-12	FTHQ1206__	18	22	0,8	43	-	18	8	20	7	59,5	26	30305026

* vedere pagine 660-661

Altre forme del tagliente, dimensioni e angoli di regolazione su richiesta.

Fornitura: Cartuccia con componenti integrati. Inserti a fissaggio meccanico e componenti accessori vanno ordinati separatamente.

Misure in mm.

Cartuccia compatta per inserti a fissaggio tangenziale

Forma 80

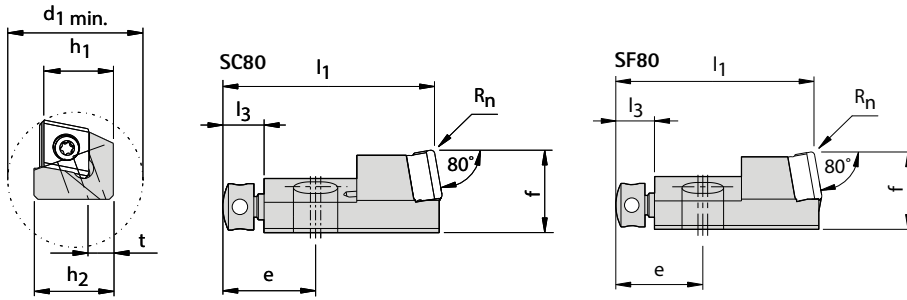

Disegni in versione destra, esempio SC80NR.

Serie selezionata per il magazzino

	Specifiche	Inserto corrispondente	Dimensioni										Gruppo accessori*	Codice
			h_1	f (riferito a R_n)	R_n	l_1	l_2	e	l_3	h_2	t	d_1 min.		
SC80...	SC80NR 10CT-06	CTHQ0604__	10	11	0,8	29	-	12	5	10,5	5	40	23	30305016
	SC80NR 14CT-09	CTHQ0905__	14	16	0,8	41	-	18	8	16	7	65	25	30305019
	SC80NR 18CT-12	CTHQ1206__	18	22	0,8	43	-	18	8	20	7	75	27	30305021
SF80...	SF80NR 10CT-06	FTHQ0604__	10	11	0,8	29	-	12	5	10,5	5	35	23	30305023
	SF80NR 14CT-09	FTHQ0905__	14	16	0,8	41	-	18	8	16	7	44	25	30305025
	SF80NR 18CT-12	FTHQ1206__	18	22	0,8	43	-	18	8	20	7	59,5	27	30305027

* vedere pagine 660-661

Altre forme del tagliente, dimensioni e angoli di regolazione su richiesta.

Fornitura: Cartuccia con componenti integrati. Inserti a fissaggio meccanico e componenti accessori vanno ordinati separatamente.

Misure in mm.

Cartuccia compatta per inserti a fissaggio tangenziale

Forma S, T, R

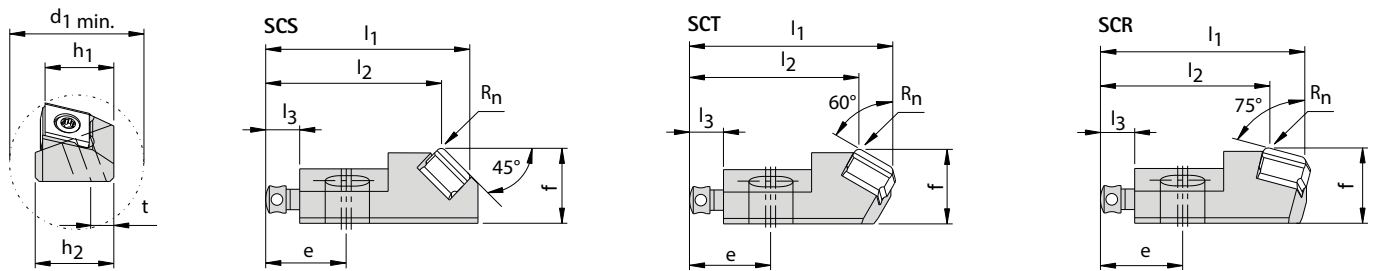

Disegni in versione destra, esempio SCSNR.

Serie selezionata per il magazzino

Specifiche	Inserto corrispondente	Dimensioni											Gruppo accessori *	Codice
		h_1	f (riferito a R_n)	R_n	l_1	l_2	e	l_3	h_2	t	$d_1 \text{ min.}$			
SCS...	SCSNR 14 CT-09	CTHQ0905__	14	16	0,8	42,5	36	18	8	16	7	65	30	30552283
SCT...	SCTNR 10 CT-06	CTHQ0604__	10	11	0,8	30	24,7	12	5	10,5	5	40	22	30552284
	SCTNR 14 CT-09	CTHQ0905__	14	16	0,8	42,5	34,4	18	8	16	7	65	20	30552285
	SCTDR 10 CT-06	CTHD0603__	10	11	0,8	30	24,7	12	5	10,5	5	40	22	30552274
SCR...	SCRNR 14 CT-09	CTHQ0905__	14	16	0,8	42,5	33,3	18	8	16	7	65	20	30552287

* vedere pagine 660-661

Altre forme del tagliente, dimensioni e angoli di regolazione su richiesta.

Fornitura: Cartuccia con componenti integrati. Inserti a fissaggio meccanico e componenti accessori vanno ordinati separatamente.

Misure in mm.

Cartuccia compatta per inserti a fissaggio tangenziale

Forma S, T, 20, R

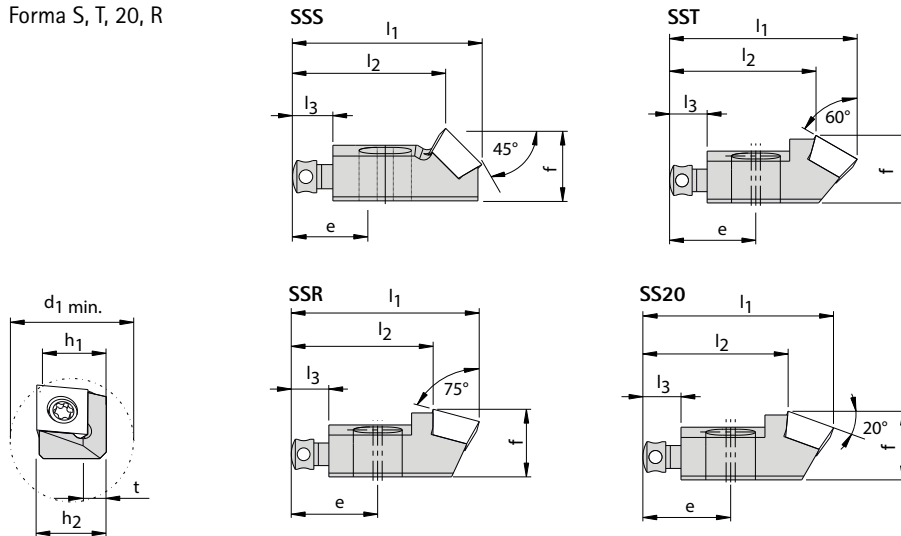

Disegni in versione destra, esempio SSDR.

Serie selezionata per il magazzino

	Specifiche	Inserto corrispondente	Dimensioni									Gruppo accessori *	Codice
			h_1	f	l_1	l_2	e	l_3	h_2	t	$d_{1 \text{ min.}}$		
SSS...	SSSDR 08CT-06	STHD0603__	8,5	9	23,5	19	11,5	5	8,2	3,2	33	28	30474905
	SSSDR 14CT-09	STHD09T3__	14	13,5	35,7	29	18	8	13,5	5	50	32	30474906
SST...	SSTDR 08 CT-06	STHD0603__	8,5	9	25	19,5	11,5	5	8,2	3,2	33	28	30552292
	SSTDR 14 CT-09	STHD09T3__	14	13,5	38	29,8	18	8	13,5	5	50	32	30552293
SS20...	SS20DR 08 CT-06	STHD0603__	8,5	9	25	19	11,5	5	8,2	3,2	33	28	30552294
	SS20DR 14 CT-09	STHD09T3__	14	13,5	38	29	18	8	13,5	5	50	32	30552295
SSR...	SSRDR 08 CT-06	STHD0603__	8,2	9	25	18,9	11,5	5	8,2	3,2	33	28	30552288
	SSRDR 14 CT-09	STHD09T3__	14	13,5	38	28,8	18	8	13,5	5	50	32	30552289

* vedere pagine 660-661

Altre forme del tagliente, dimensioni e angoli di regolazione su richiesta.

Fornitura: Cartuccia con componenti integrati. Inserti a fissaggio meccanico e componenti accessori vanno ordinati separatamente.

Misure in mm.

Accessori per cartuccia ISO e cartuccia compatta

In struttura radiale e tangenziale



Gruppo accessori	Vite di fissaggio per cartuccia			Vite di regolazione assiale		Vite di regolazione radiale		
	Descrizione per l'ordine Vite a testa cilindrica	Coppia di serraggio [Nm]*	Codice	Descrizione per l'ordine Vite a croce	Codice	Descrizione per l'ordine Grano filettato	Codice	
Cartuccia ISO	1	DIN7984 M6x20-10.9	12	10019671	M5 x 10	10029150	DIN913 M4x10-45H	10003433
	2	DIN7984 M4x12-10.9	3	10019695	M3 x 8	10002641	DIN913 M3x6-45H	10003422
	3	DIN7984 M4x12-10.9	3	10019695	M3 x 8	10002641	DIN913 M3x6-45H	10003422
	4	DIN7984 M6x16-10.9	12	10019703	M5 x 10	10029150	DIN913 M4x8-45H	10003432
	5	DIN7984 M6x16-10.9	12	10019703	M5 x 10	10029150	DIN913 M4x8-45H	10003432
	6	DIN7984 M6x20-10.9	12	10019671	M5 x 10	10029150	DIN913 M4x10-45H	10003433
Cartuccia compatta	7	MN685 M6x25-TX25-IP	12	30606074	M5 x 7	10018493	DIN915 M4x10-45H	10003900
	8	MN685 M6x25-TX25-IP	12	30606074	M5 x 7	10018493	DIN915 M4x10-45H	10003900
	9	MN685 M3x10-TX9-IP	1,8	30606065	M3 x 5	10025039	DIN915 M3x6-45H	10003894
	10	MN685 M3x10-TX9-IP	1,8	30606065	M3 x 5	10025039	DIN915 M3x6-45H	10003894
	11	MN685 M6x20-TX25-IP	12	30606068	M5 x 7	10018493	DIN915 M4x10-45H	10003900
	12	MN685 M6x25-TX25-IP	12	30606074	M5 x 7	10018493	DIN915 M4x10-45H	10003900
	13	MN685 M4x14-TX15-IP	3	30606067	M3 x 5	10025039	DIN915 M3x6-45H	10003894
	14	MN685 M6x20-TX25-IP	12	30606068	M5 x 7	10018493	DIN915 M4x10-45H	10003900
	15	MN685 M6x20-TX25-IP	12	30606068	M5 x 7	10018493	DIN915 M4x10-45H	10003900
	16	MN685 M6x20-TX25-IP	12	30606068	M5 x 7	10018493	DIN915 M4x10-45H	10003900
17	MN685 M3x10-TX9-IP	1,8	30606065	M3 x 5	10025039	DIN915 M3x6-45H	10003894	
Cartuccia compatta tangenziale	18	ISO 4762-M6X25-12.9	12	10003620	M5 x 7	10018493	ISO 4028-M4x10-45H-KL	30351530
	19	ISO 4762-M6X25-12.9	12	10003620	M5 x 7	10018493	ISO 4028-M4x10-45H-KL	30351530
	20	DIN 7984-M6X20-10.9	12	10019671	M5 x 7	10018493	ISO 4028-M4x10-45H-KL	30351530
	21	DIN 7984-M6X20-10.9	12	10019671	M5 x 7	10018493	ISO 4028-M4x10-45H-KL	30351530
	22	DIN 7984-M4X16-10.9	3	10019685	M3 x 5	10025039	ISO 4028-M3x6-45H-KL	30351529
	23	DIN 7984-M4X16-10.9	3	10019685	M3 x 5	10025039	ISO 4028-M3x6-45H-KL	30351529
	24	DIN 7984-M6X20-10.9	12	10019671	M5 x 7	10018493	ISO 4028-M4x10-45H-KL	30351530
	25	DIN 7984-M6X20-10.9	12	10019671	M5 x 7	10018493	ISO 4028-M4x10-45H-KL	30351530
	26	ISO 4762-M6X25-12.9	12	10003620	M5 x 7	10018493	ISO 4028-M4x10-45H-KL	30351530
	27	ISO 4762-M6X25-12.9	12	10003620	M5 x 7	10018493	ISO 4028-M4x10-45H-KL	30351530
	28	MN685 M4x14-TX15-IP	3	30606067	M3 x 5	10025039	-	-
	29	ISO 4762-M6X25-12.9	12	10003620	M5 x 7	10018493	-	-
	30	DIN 7984-M6X20-10.9	12	10019671	M5 x 7	10018493	ISO 4028-M4x10-45H-KL	30351530
	31	DIN 7984-M4X16-10.9	3	10019685	M3 x 5	10025039	ISO 4028-M3x6-45H-KL	30351529
	32	MN685 M6x20-TX25-IP	12	30606068	M5 x 7	10018493	-	-

* Coppie di serraggio secondo MN678

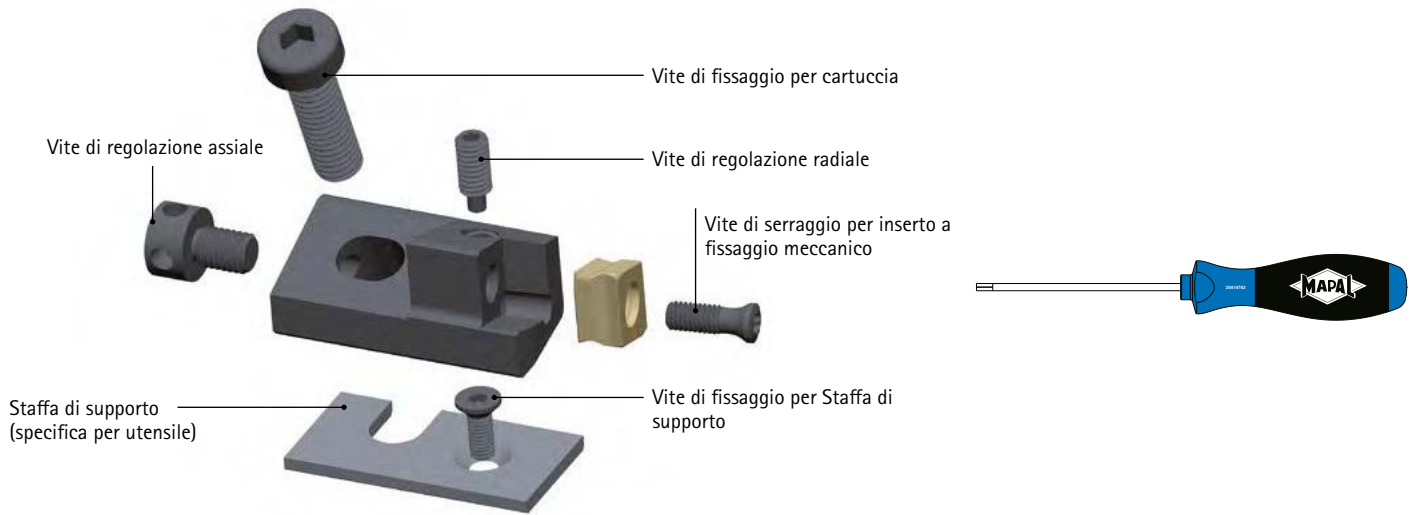

Staffa di supporto destra		Staffa di supporto sinistra		Vite di fissaggio per Staffa di supporto		
Descrizione per l'ordine Staffa di supporto	Codice	Descrizione per l'ordine Staffa di supporto	Codice	Descrizione per l'ordine Vite a testa svasata	* Coppia di serraggio [Nm]	Codice
UR 12-1A	Su richiesta	UL 12-1A	Su richiesta	ISO 10642-M3X8-10.9	1,8	10003769
UR 08-1A	Su richiesta	UL 08-1A	Su richiesta	ISO 10642-M3X6-10.9	1,8	10003768
UR 08-1A	Su richiesta	UL 08-1A	Su richiesta	ISO 10642-M3X6-10.9	1,8	10003768
UR 10-1A	Su richiesta	UL 10-1A	Su richiesta	ISO 10642-M3X8-10.9	1,8	10003769
UR 10-1A	Su richiesta	UL 10-1A	Su richiesta	ISO 10642-M3X8-10.9	1,8	10003769
UR 12-1A	Su richiesta	UL 12-1A	Su richiesta	ISO 10642-M3X8-10.9	1,8	10003769
UR 12-1K	Su richiesta	UL 12-1K	Su richiesta	ISO 10642-M3X8-10.9	1,8	10003769
UR 12-2K	Su richiesta	UL 12-2K	Su richiesta	ISO 10642-M3X8-10.9	1,8	10003769
UR 06-1K	Su richiesta	UL 06-1K	Su richiesta	ISO 2009-M2X4-4.8	0,5	10029153
UR 06-2K	Su richiesta	UL 06-2K	Su richiesta	ISO 2009-M2X4-4.8	0,5	10029153
UR 10-1K	Su richiesta	UL101K	Su richiesta	ISO 10642-M3X8-10.9	1,8	10003769
UR 12-1K	Su richiesta	UL 12-1K	Su richiesta	ISO 10642-M3X8-10.9	1,8	10003769
UR 08-1K	Su richiesta	UL 08-1K	Su richiesta	ISO 10642-M3X6-10.9	1,8	10003768
UR 10-1K	Su richiesta	UL 10-1K	Su richiesta	ISO 10642-M3X8-10.9	1,8	10003769
UR 10-2K	Su richiesta	UL 10-2K	Su richiesta	ISO 10642-M3X8-10.9	1,8	10003769
UR 10-3K	Su richiesta	UL 10-3K	Su richiesta	ISO 10642-M3X8-10.9	1,8	10003769
UR 06-1K	Su richiesta	UL 06-1K	Su richiesta	ISO 2009-M2X4-4.8	0,5	10029153
UR 18-1T	Su richiesta	-	-	ISO 10642-M3X8-10.9	1,8	10003769
UR 18-4T	Su richiesta	-	-	ISO 10642-M3X8-10.9	1,8	10003769
UR 14-1T	Su richiesta	-	-	ISO 10642-M3X8-10.9	1,8	10003769
UR 14-4T	Su richiesta	-	-	ISO 10642-M3X8-10.9	1,8	10003769
UR 10-1T	Su richiesta	-	-	ISO 10642-M3X8-10.9	1,8	10003769
UR 10-2T	Su richiesta	-	-	ISO 10642-M3X8-10.9	1,8	10003769
UR 14-2T	Su richiesta	-	-	ISO 10642-M3X8-10.9	1,8	10003769
UR 14-3T	Su richiesta	-	-	ISO 10642-M3X8-10.9	1,8	10003769
UR 18-2T	Su richiesta	-	-	ISO 10642-M3X8-10.9	1,8	10003769
UR 18-3T	Su richiesta	-	-	ISO 10642-M3X8-10.9	1,8	10003769
-	-	-	-	-	-	-
-	-	-	-	-	-	-
UR 14-5T	Su richiesta	-	-	ISO 10642-M3X8-10.9	1,8	10003769
UR 10-3T	Su richiesta	-	-	ISO 10642-M3X8-10.9	1,8	10003769
-	-	-	-	-	-	-



INSERTI A FISSAGGIO MECCANICO

Introduzione

Serie di materiali da taglio	664
Panoramica prodotti	666
Riepilogo materiali da taglio	670
Codice di denominazione	676
Panoramica gradini di convoglio dei trucioli	680

Inserti a fissaggio meccanico

Inserti a fissaggio radiale	686
Inserti a fissaggio tangenziale.....	708
Accessori	730

Allegato tecnico

Parametri di lavorazione consigliati	732
--	-----

Serie di materiali da taglio – il materiale da taglio giusto per ogni applicazione

La vasta offerta di inserti a fissaggio meccanico MAPAL di tipo radiale e tangenziale è in grado di soddisfare le più disparate esigenze in termini di materiali da taglio e rivestimenti, oltre che adattarsi alle diverse geometrie del tagliente e range di precisione richiesti.

Serie di materiali da taglio Performance Line

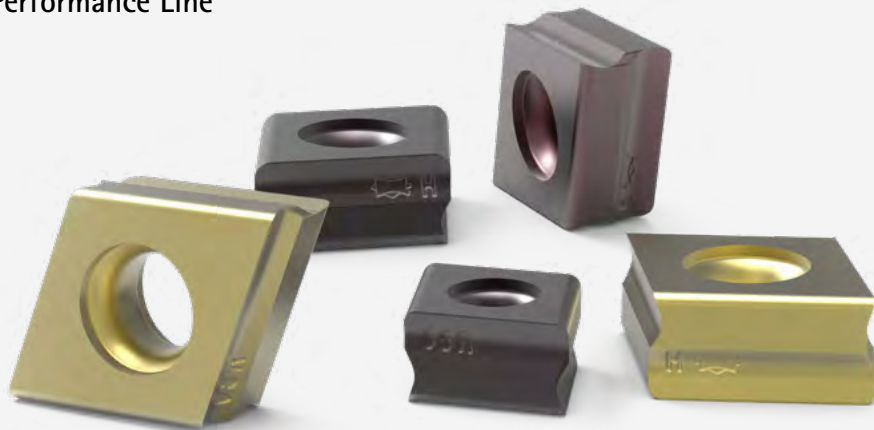

La serie di materiali da taglio Performance Line comprende una vasta offerta di inserti a fissaggio meccanico di tipo radiale e tangenziale in grado di soddisfare le più disparate esigenze in termini di materiali da taglio e rivestimenti, oltre che adattarsi alle diverse geometrie del tagliente e range di precisione richiesti.

Levigati ad alta precisione in classe di tolleranza H, gli inserti a fissaggio meccanico consentono una reale lavorazione multitagliente, anche in presenza di taglienti integrati in maniera fissa. Insieme a sedi dell'inserto realizzate con la massima precisione, il sistema dei taglienti consente infatti di ridurre al minimo le deviazioni reciproche. Ciò si traduce nella concreta possibilità di utilizzare contemporaneamente tutti i taglienti e quindi in un notevole incremento delle prestazioni.

Gli inserti a fissaggio tangenziale sinterizzati in classe di tolleranza N ampliano l'assortimento offrendo alternative particolarmente interessanti sotto il profilo economico, soprattutto per quelle lavorazioni che ammettono maggiori tolleranze. Tra le novità in assortimento figurano gli inserti a fissaggio meccanico di tipo radiale e tangenziale con rettifica periferica in classe di tolleranza G, presentati come l'alternativa conveniente agli inserti ad elevata precisione.

IN SINTESI

- Vasta offerta di inserti a fissaggio meccanico di tipo radiale e tangenziale
- L'assortimento spazia da inserti a fissaggio meccanico levigati ad alta precisione in classe di tolleranza H fino a inserti sinterizzati in classe di tolleranza N e G
- Vasta scelta di materiali da taglio per pressoché tutti i campi di applicazione
- Varianti con riporto in PCD e PcBN per una lavorazione altamente conveniente di alluminio o ghisa

Contrassegni per inserto a fissaggio meccanico pressati "press-to-size"

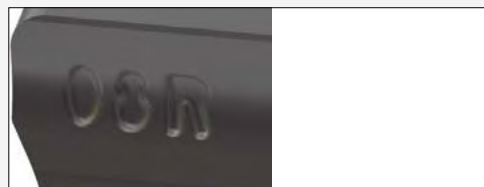

Serie di materiali da taglio Basic Line

P M K

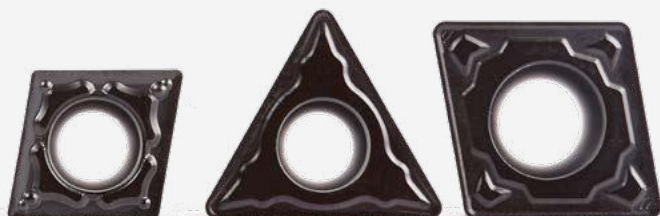

L'assortimento Basic Line di inserti radiali positivi per la barenatura e la tornitura convince per l'eccellente rapporto qualità-prezzo. Per la lavorazione di ghisa, acciaio e acciaio inossidabile sono disponibili i nuovi materiali da taglio con rivestimento in CVD e PVD, che coprono una vasta gamma di caratteristiche dalla resistenza all'usura alla tenacità. In questo modo è possibile scegliere, per ogni applicazione, l'inserto a fissaggio meccanico ideale. A seconda della lavorazione sono disponibili diverse forme di base con tre diversi gradini di convoglio dei trucioli in classe di tolleranza M e G per la sgrossatura, la lavorazione media e la finitura.

IN SINTESI

- Taglienti radiali positivi per barenatura e tornitura
- Eccellente rapporto qualità-prezzo
- Materiali da taglio rivestiti in CVD e PVD per lavorazioni in P, M e K
- Taglienti in cermet per un'elevata qualità superficiale nell'acciaio
- Diversi gradini di convoglio dei trucioli per la sgrossatura, per la lavorazione media e per la finitura

Serie di materiali da taglio per la lavorazione mista

N+K N+P



L'impiego di combinazioni di materiali quali alluminio e acciaio sinterizzato oppure alluminio e ghisa, impiegate ad esempio nel caso della realizzazione di carter, impone elevati requisiti in termini di asportazione truciolo. Per queste lavorazioni, MAPAL offre una serie di materiali da taglio dedicata. Sia i substrati in metallo duro che le micro e le macro geometrie dei taglienti sono stati sviluppati specificamente per la lavorazione mista.

Il rivestimento in PVD come parte della serie di materiali da taglio impedisce da un lato il tagliente di riporto durante la lavorazione dell'alluminio e dall'altro un'eccessiva usura in fase di asportazione truciolo della porzione in ghisa e/o acciaio sinterizzato sul pezzo. Ne deriva un materiale da taglio altamente resistente all'usura e al calore, per una lavorazione ai vertici della qualità.

IN SINTESI

- Materiale da taglio per la lavorazione delle combinazioni di materiali alluminio-ghisa e alluminio-acciaio sinterizzato
- Substrati in metallo duro riadattati, micro e macro-geometrie dei taglienti ottimizzate, rivestimento in PVD basato su una lega TiAlN con speciale elemento di dotazione
- Disponibilità di inserti a fissaggio meccanico ISO sia standard che speciali
- Lunga durata e quindi elevata redditività

Panoramica prodotti: inserti a fissaggio meccanico 1/2

Tecnologia a fissaggio radiale

Tipo di inserto	Tecnologia a fissaggio radiale – Basic Line							
	CCMT	CCGT	DCMT	SCMT SPMT	SCGT	TCMT	VCMT	VCGT
								

Caratteristiche

Numero di taglienti	2	2	2	4	4	3	2	2
Dimensioni dell'inserto	06 / 09 / 12	06 / 09 / 12	07 / 11 / 15	06 / 09 / 12	09	09 / 11 / 16 / 22	16	11
Range di diametro	da 17 mm	da 17 mm		da 17 mm	da 25 mm	da 17 mm		
Direzione di taglio	N	N	N	N	N	N	N	N
Barenatura – neutra	■	■	■	■	■	■	■	■
Barenatura – arrotondamento								
Svasatura/smussatura								

Applicazione

Sgrossatura	■		■	■		■	■	
Lavorazione media	■	■	■	■		■	■	■
Finitura	■	■	■	■	■	■		

Materiale da taglio

Metallo duro levigato		■						■
Metallo duro pressato	■		■	■		■	■	
Cermet		■	■		■	■	■	
PcBN								
PCD								

Idoneità del materiale

P	■	■	■	■	■	■	■	■
M ₁	■	■	■	■		■		■
M ₂	■	■	■	■		■		■
K	■		■	■		■	■	
N								
N K								
N P								

Pagina	686	688	692	694	694	700	704	704
--------	-----	-----	-----	-----	-----	-----	-----	-----

Panoramica prodotti: inserti a fissaggio meccanico 2/2

Tecnologia tangenziale

Tipo di inserto	Tecnologia a fissaggio radiale – Performance Line							
	CCGT	CCGW	DCGT	DCGW	SCGT SPGT	SCGW SPGW	TCGW	VBGW VCGW
								

Caratteristiche

Numero di taglienti	1	1	1	1	1	1	1	1
Dimensioni dell'inserto	06 / 09	06 / 09	11	11	06 / 09	06 / 09 / 12	11	16
Range di diametro	da 17 mm	da 17 mm			da 17 mm	da 17 mm	da 17 mm	
Direzione di taglio	N	N	N	N	L / R / N	N	N	N
Barenatura neutra	■	■	■	■	■	■	■	■
Barenatura con arrotondamento								
Svasatura/smussatura								

Applicazione

Sgrossatura								
Lavorazione media	■	■	■			■	■	
Finitura	■	■	■	■	■	■	■	■

Materiale da taglio











Metallo duro levigato								
Metallo duro pressato								
Cermet								
PcBN		■		■		■	■	■
PCD	■	■	■	■	■	■	■	

Idoneità del materiale

P								
M ₁								
M ₂								
K		■		■		■	■	■
N	■	■	■	■	■	■	■	
N K								
N P								

Pagina	688	689	692	692	694	696	700	704
--------	-----	-----	-----	-----	-----	-----	-----	-----

Tecnologia a fissaggio tangenziale – Performance Line

	CTNQ	CTGQ	CTHQ		FTNQ	FTGQ	FTHQ		STHD / STHE	
										
	4	4	4	1	4	4	4	1	4	1
	09 / 12	09 / 12	06 / 09 / 12	06 / 09 / 12	09 / 12	09 / 12	06 / 09 / 12	06 / 09 / 12	06 / 09	06 / 09
	da 41 mm	da 65 mm	da 28 mm	da 28 mm	da 30 mm	da 30 mm	da 22 mm	da 22 mm		
	L / R	L	L / R	L / R	L / R	L	L / R	L / R	N	N
	■		■	■	■		■	■		
		■	■	■		■	■	■		
									■	■
	■	■	■	■	■	■	■	■		
	■	■	■	■	■	■	■	■		
	■		■			■	■		■	
		■			■					
				■				■		■
	■	■	■		■	■	■			
	■	■	■		■	■	■			
	■	■	■		■	■	■		■	
	■		■		■	■	■		■	
			■	■		■	■	■	■	■
	708	710	712	712	718	720	722	722	728	728

Riepilogo materiali da taglio: come scegliere il materiale da taglio giusto

Come scegliere il materiale da taglio

I materiali da taglio soddisfano un'ampia gamma di requisiti, fra cui la resistenza all'usura e la tenacità. La denominazione del materiale da taglio è strutturata in modo che la tenacità aumenti parallelamente all'aumentare del numero.

I materiali da taglio con rivestimento in PVD (HC...) sono la prima scelta per la barenatura di materiali K, P e M, dove assicurano durate massime.

Esempio: HC830 è più resistente di HC815 (più il materiale da taglio è tenace, minore è la resistenza all'usura).

Nel caso dei materiali non ferrosi, la prima scelta è rappresentata da tipologie di metallo duro (HU.../HP...) rivestite in PCD. A partire da una percentuale di silicio $\geq 12\%$ si raccomanda, per via della crescente abrasività, l'uso di PCD (PU...). Garanzia di massima durata, il PCD è un materiale da taglio particolarmente adatto alle grandi serie.

1. Selezionare il materiale secondo i GTM (gruppi di materiale MAPAL, vedi pagina pieghevole alla fine del catalogo).

2. A seconda della linea di prodotto, selezionare dalla **tabella "Riepilogo materiali da taglio"** il tipo collocato al di sotto del materiale desiderato.

3. A seconda delle condizioni generali (vedere **tabella "Condizioni generali"**), è bene scegliere un materiale da taglio rivestito in CVD più resistente all'usura o più tenace.

4. Se sono maggiori le condizioni generali in direzione delle frecce nere, e qualora non sia possibile impedire rotture nonostante una tipologia CVD più tenace, sarà necessario passare a materiali da taglio con rivestimento in PVD.

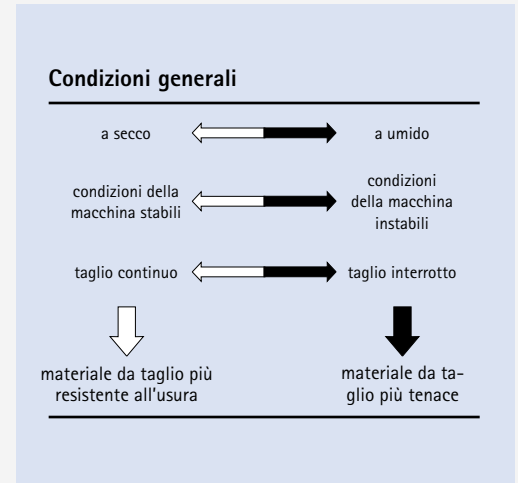

Riepilogo materiali da taglio Basic Line

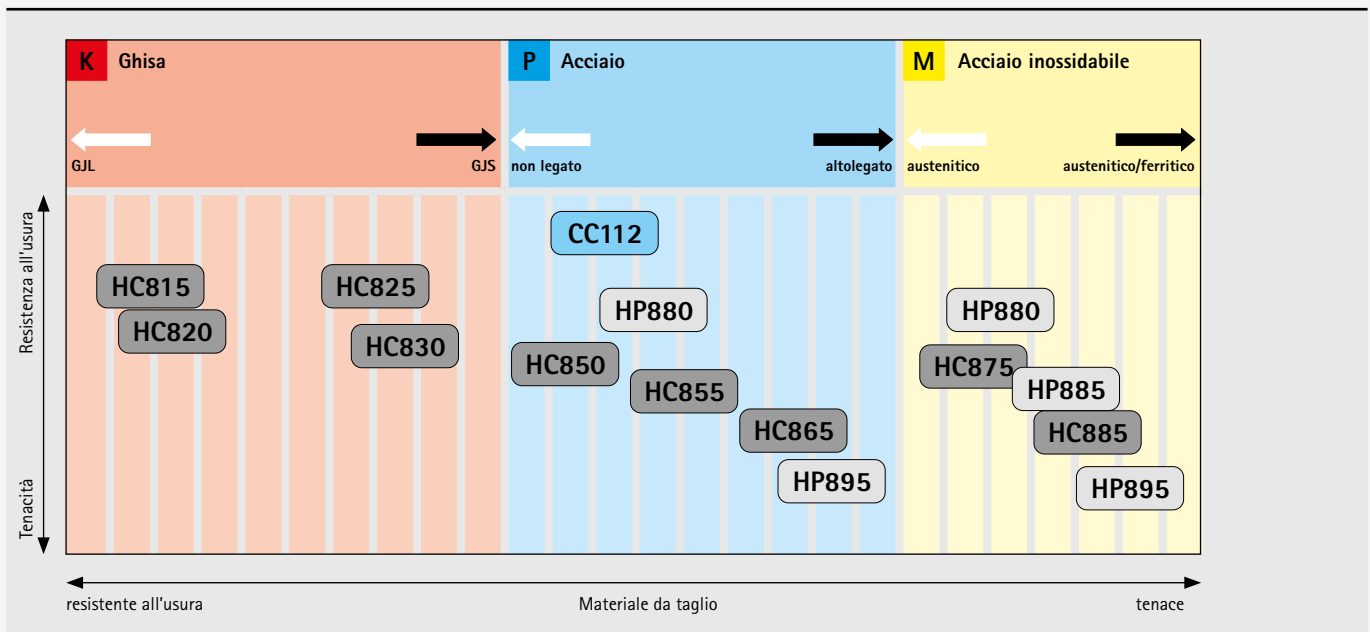

CVD

PVD

Cermet, CVD

Come scegliere il materiale da taglio

1. Selezionare dalla **tabella "Riepilogo materiali da taglio"** il tipo collocato al di sotto del materiale desiderato.

2. Nella lavorazione mista di alluminio e ghisa, la qualità HP530-P è la prima scelta, mentre nel caso di alluminio e acciaio la prima scelta è la qualità HP545-P.

3. Se è garantito un processo stabile con un'usura normale, è possibile scegliere una tipologia più resistente all'usura, HP525-P per alluminio-ghisa oppure HP540-P per alluminio-acciaio, per ottenere delle durate utili maggiori.

Riepilogo materiali da taglio per lavorazione mista

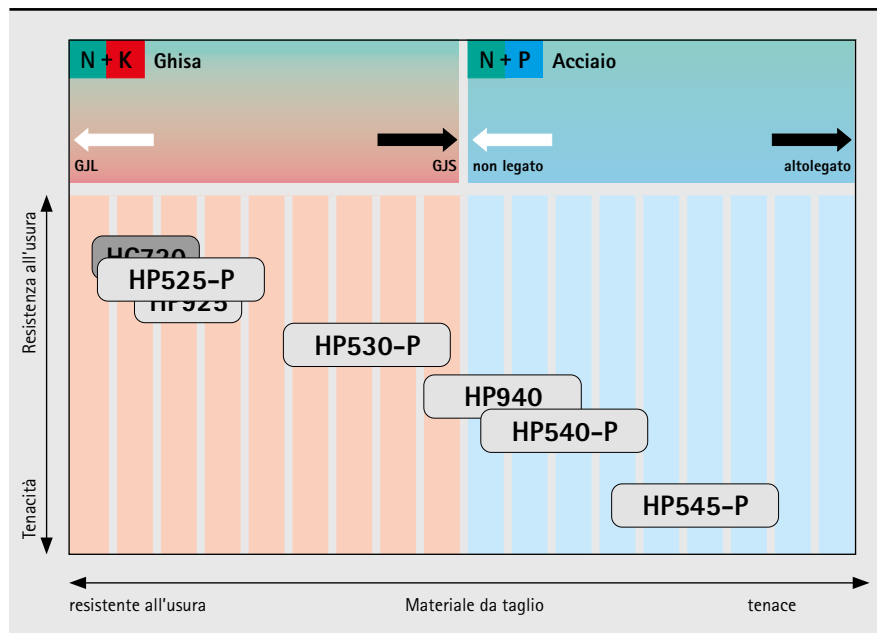

Lucidato in PVD

Riepilogo materiali da taglio Performance Line

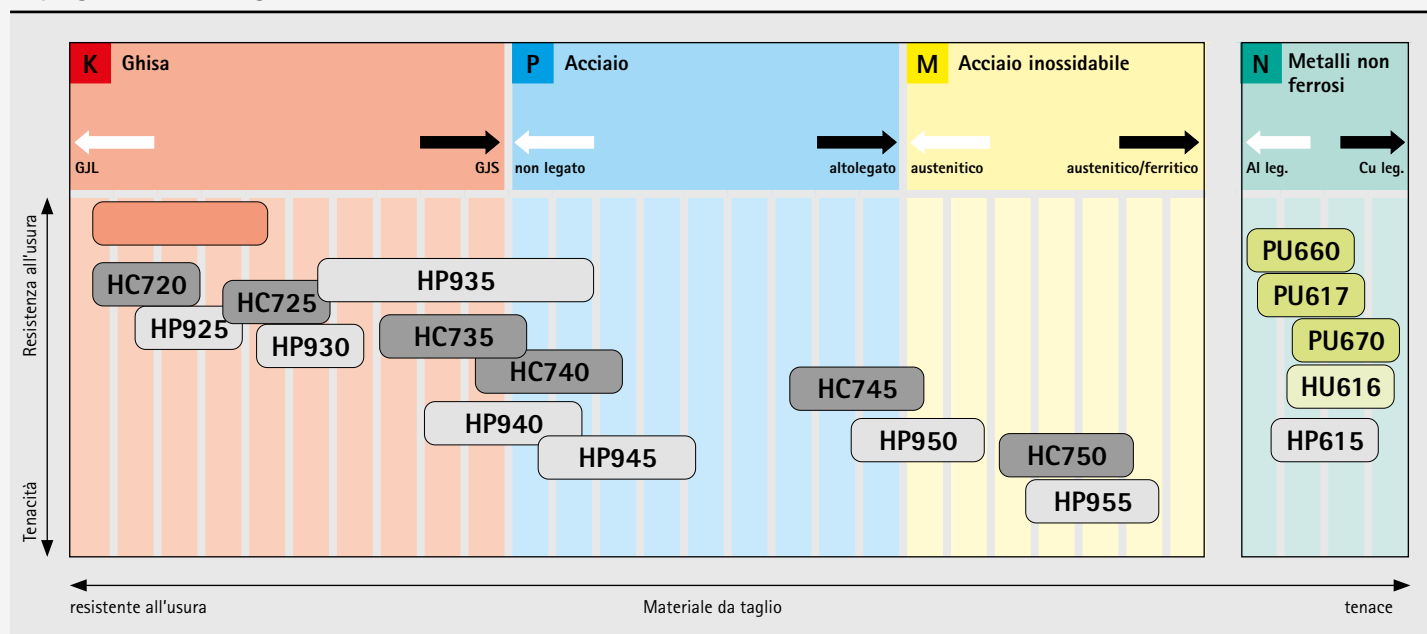

CVD

PVD

PcBN

PCD

non rivestito

Riepilogo materiali da taglio: Tipologie e relativa descrizione 1/2

Substrato	Rivestimento	Materiale da taglio	Composizione strato	Colore rivestimento	Campo di applicazione	Applicazione consigliata
Cermet	Rivestito in CVD	CC112	TiCN+Al ₂ O ₃	A più colori	●	Tipo di Cermet a grana finissima con rivestimento in Al ₂ O ₃ per finitura e semilavorazione di acciaio e materiali in ghisa con elevate velocità di taglio.
PcBN	Non rivestito	FU430	-	-	●	Tipo di PcBN ad alto contenuto di CBN per finitura e semifinitura di GJL e metallo sinterizzato.
Metallo duro	Rivestito in CVD	HC698*	Diamante	Nero-antracite	●	Metallo duro con rivestimento diamantato in CVD per la lavorazione dell'alluminio.
		HC725	TiCN+Al ₂ O ₃	Nero	●	Metallo duro a grana finissima con elevata resistenza all'usura e rivestimento CVD a più strati con strato di copertura Al ₂ O ₃ per la lavorazione di GJL e GJS con elevate velocità di taglio. Per taglio da liscio a leggermente interrotto, dalla lavorazione media fino alla lavorazione di sgrossatura.
		HC740	TiCN+Al ₂ O ₃	Nero	●	Metallo duro a grana fine con elevata resistenza all'usura e con rivestimento in CVD a più strati con copertura in Al ₂ O ₃ . Per taglio da liscio a leggermente interrotto, dalla lavorazione media fino alla lavorazione di sgrossatura in GJS, acciaio non legato e acciaio fuso resistente al calore.
		HC745	TiCN+Al ₂ O ₃	Nero	⚡	Metallo duro a grana fine con un rapporto bilanciato tra resistenza all'usura e tenacia e con rivestimento CVD a più strati con copertura in Al ₂ O ₃ per la lavorazione ad elevate velocità di taglio. Per taglio interrotto o condizioni instabili e materiali con elevata resistenza alla trazione, acciaio da altolegato a inossidabile e acciaio fuso resistente al calore.
		HC750	TiCN+Al ₂ O ₃	Nero	⚡	Metallo duro a grana fine con un rapporto bilanciato della tenacia e con un rivestimento CVD a più strati con strato di copertura Al ₂ O ₃ . Per taglio interrotto o condizioni instabili e materiali con massima resistenza alla trazione, acciaio inossidabile e acciaio fuso resistente al calore.
		HC815	TiCN+Al ₂ O ₃	Nero	●	Tipologia di metallo duro a grana fine resistente all'usura con rivestimento Al ₂ O ₃ . Adatto alla lavorazione di materiali in ghisa in condizioni stabili.
		HC820	TiCN+Al ₂ O ₃	Nero	●	Metallo duro con rivestimento in Al ₂ O ₃ con trattamento successivo ottimizzato per incrementare la stabilità dei taglienti. Adatto per la lavorazione di GJL in condizioni stabili e con taglio leggermente interrotto.
		HC825	TiCN+Al ₂ O ₃	Nero	●	Elevata resistenza all'usura grazie allo spesso rivestimento CVD. Adatto alla lavorazione di ghisa in condizioni instabili.
		HC830	TiCN+Al ₂ O ₃	Nero	●	Tipologia di metallo duro a grana fine con rivestimento spesso e stabilità dei taglienti migliorata. Adatto a tagli fortemente interrotti nella lavorazione della ghisa.
		HC850	TiCN+Al ₂ O ₃ +TiN	Oro	●	Metallo duro gradiente con rivestimento in MT-TiCN e Al ₂ O ₃ e strato superficiale TiN. Adatto alla lavorazione di acciaio per via della ridotta ruvidità della superficie.
		HC855	TiCN+Al ₂ O ₃ +TiN	Oro	●	Metallo duro gradiente con rapporto bilanciato tra tenacità e resistenza all'usura. Adatto a lavorazioni di semi-finitura e alla lavorazione media di acciaio.
		HC865	TiCN+Al ₂ O ₃ +TiN	Oro	⚡	Tipologia tenace di metallo duro gradiente con rivestimento in Al ₂ O ₃ e strato superficiale TiN liscio. Adatto a lavorazioni di semi-finitura e alla lavorazione media di acciaio e acciaio legato.
		HC875	TiCN+Al ₂ O ₃ +TiN	Oro	●	Tipologia di metallo duro gradiente a grana fine con sottile rivestimento CVD. Adatto alla lavorazione di acciaio altolegato e acciaio inossidabile.
		HC885	TiCN+Al ₂ O ₃ +TiN	Oro	⚡	Tipologia di metallo duro con elevata tenacità e rivestimento CVD. Adatto alla lavorazione di acciaio inossidabile.

* Materiale da taglio per la foratura di alluminio.

	P Acciaio						M Acciaio inossidabile						K Ghisa						N Metalli non ferrosi						N+K Lavorazione mista		P+K Lavorazione mista		
	resistente all'usura			tenace			resistente all'usura			tenace			resistente all'usura			tenace			resistente all'usura			tenace			resistente all'usura		tenace		
	05	15	25	35	45		05	15	25	35	45		05	15	25	35	45		05	15	25	35	45		Ghisa			Acciaio sinterizzato	
	01	10	20	30	40	50	01	10	20	30	40	50	01	10	20	30	40	50	01	10	20	30	40	50	GJL	GJS	non legato	altollegato	
	■	■					■	■	■																				
													■	■	■														
															■	■													
															■	■													
	■	■					■	■								■	■												
			■	■					■	■																			
										■	■																		
													■	■															
															■	■													
	■	■														■	■												
	■	■																											
			■	■																									
							■	■																					
										■	■																		

Riepilogo materiali da taglio: Tipologie e relativa descrizione 2/2

Substrato	Rivestimento	Materiale da taglio	Composizione strato	Colore rivestimento	Campo di applicazione	Applicazione consigliata	
Metallo duro	Con rivestimento in PVD	HP615	TiB2	Antracite	●	Metallo duro a grana fine con strato in PVD a elementi ridotti per la lavorazione di materiali adesivi. Prima scelta per aumentare la durata rispetto ai taglienti non rivestiti in leghe di alluminio con 7-12% di silicio.	
		HP880	TiAlN	Antracite	●	Eccellente resistenza all'usura e resistenza al calore grazie al nuovo rivestimento in PVD. Adatto alla finitura di acciaio inossidabile.	
		HP885	TiAlN + TiAlSiN	Rame	●	Tipo di materiale da taglio termostabile, metallo duro a grana finissima con rivestimento multistrato PVD per la lavorazione universale di acciai inossidabili.	
		HP895	TiAlN	Antracite	↔	Metallo duro a grana finissima con rivestimento TiAlN ad alto contenuto di leganti. Interazione ottimizzata tra resistenza all'usura e tenacità. Adatto alla lavorazione di semi-finitura di acciaio inossidabile.	
		HP930	AlTiCrN	Nero-antracite	●	Metallo duro a grana fine con strato di copertura in PVD. Tipologia per la semilavorazione ad asportazione di truciolo e sgrossatura ad asportazione di truciolo in GJL e GJS.	
		HP945	AlTiCrN	Nero-antracite	↔	Metallo duro a grana fine con strato di copertura in PVD. Per la barenatura di acciai e acciai inossidabili, nonché di acciaio fuso resistente alle alte temperature.	
		HP950	TiAlSiN	Rame	↔	Metallo duro tenace a grana fine con strato in PVD. Per la barenatura di materiali ad elevatissima resistenza alla trazione, acciai inossidabili e acciaio fuso resistente alle alte temperature.	
	Con rivestimento in PVD, lavorazione mista	HP525-P	TiAlXN	Oro-marrone	●	Metallo duro rivestito in PVD, particolarmente indicato per la lavorazione mista di alluminio e GJL/GJS in caso di taglio liscio.	
		HP530-P	TiAlXN	Oro-marrone	●	Metallo duro rivestito in PVD, particolarmente indicato per la lavorazione mista di alluminio e GJL/GJS in caso di taglio da liscio a leggermente interrotto.	
		HP540-P	TiAlXN	Oro-marrone	●	Metallo duro rivestito in PVD, particolarmente indicato per la lavorazione mista di alluminio e acciaio sinterizzato in caso di taglio da liscio a leggermente interrotto.	
		HP545-P	TiAlXN	Oro-marrone	●	Metallo duro rivestito in PVD con un rapporto bilanciato della tenacità, particolarmente indicato per la lavorazione mista di alluminio e acciaio sinterizzato in caso di taglio da leggermente a fortemente interrotto.	
	PCD	I	PU617	-	-	●	PCD a grana media per lavorazioni da sgrossatura a semilavorazione con metalli non ferrosi e per la lavorazione di materiali molto abrasivi.
			PU660	-	-	●	Tipologia di PCD a grana fine per la finitura di metalli non ferrosi e materiali non metallici come materie plastiche rinforzate con fibre. La grana fine conferisce al tagliente un'ottima affilatura (scabrosità), insieme a un'eccellente resistenza all'usura e alla possibilità di ottenere superfici di alta qualità.
			PU670	-	-	↔	Materiale da taglio PCD con grana da media a grossolana. Eccezionale resistenza all'usura meccanica con buona tenacità, adatto in particolare alla lavorazione di materiali abrasivi.

Codice di denominazione inserti a fissaggio radiale

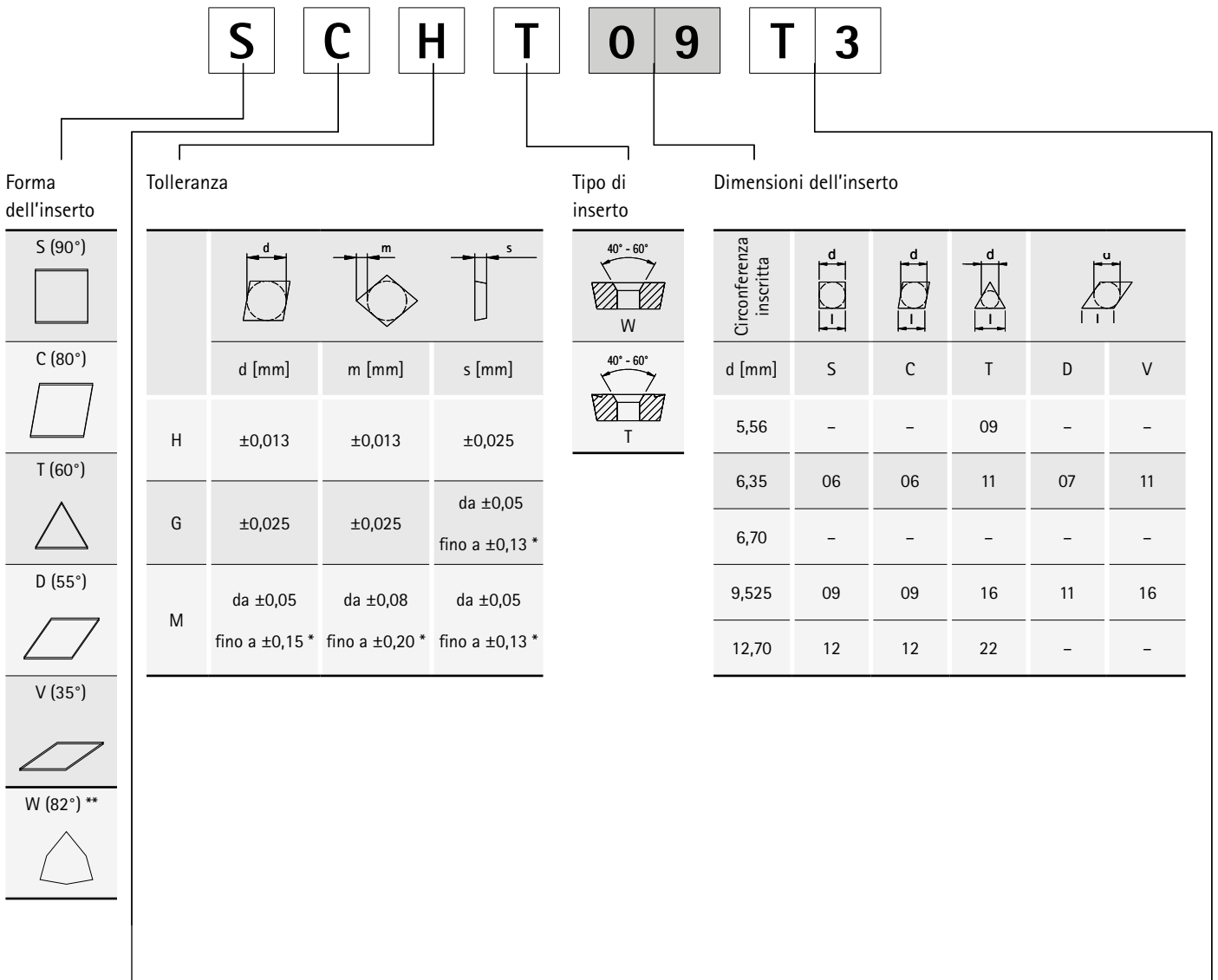

Angolo di spoglia inferiore

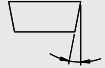
	
B	5°
C	7°
P	11°
O	Forma speciale

Spessore inserto

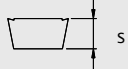
	
Numero identificativo	s [mm]
T1	1,98
02	2,38
03	3,18
T3	3,97
04	4,76

* Tolleranza in funzione della dimensione dell'inserto

** Foratura

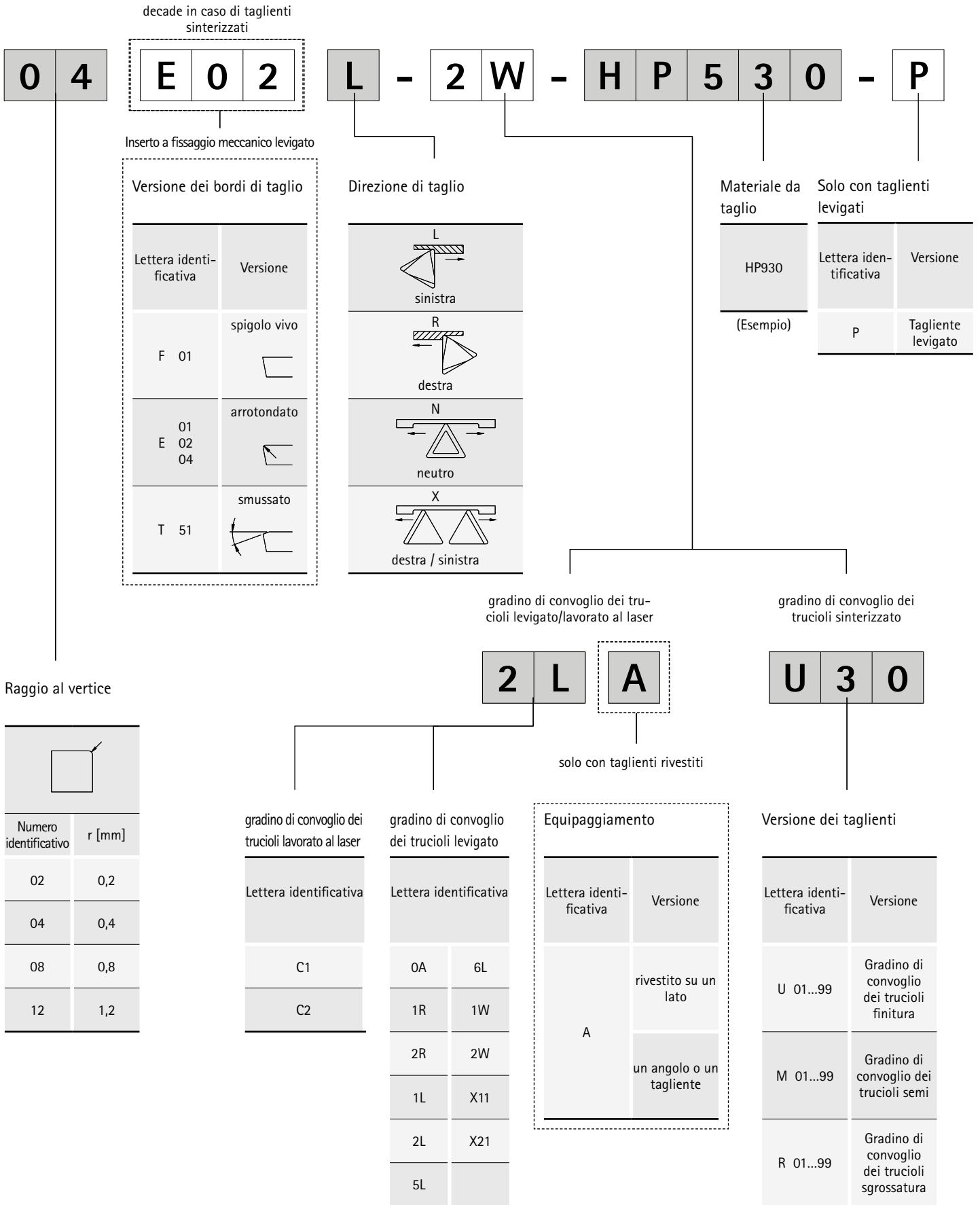

Codice di denominazione inserti a fissaggio tangenziale

C		T		H		Q		09		05		08	
Forma dell'inserto		Tolleranza		Tipo di inserto		Dimensioni dell'inserto							
C (80°)						Circonferenza inscritta							
F (70°)		d [mm]	s [mm]			d [mm]	C	F	S				
S (90°)		H	±0,013	±0,025		6,35	06/09	06	06				
		G	±0,025	±0,13		9,525	09/13	09	09				
		N	±0,05 - ±0,15	±0,025		12,7	12/18	12	-				
Inserto a fissaggio meccanico						Spessore inserto		Raggio al vertice					
T						Numero identificativo	s [mm]	Numero identificativo	r [mm]				
Tangenziale						03	3,18	00	0				
						T3	3,97	04	0,4				
						04	4,76	08	0,8				
						05	5,56	12	1,2				
						06	6,35						

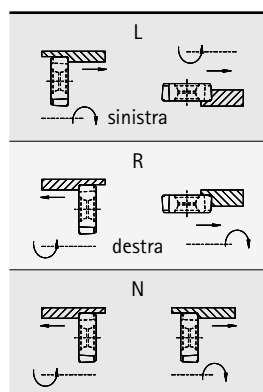
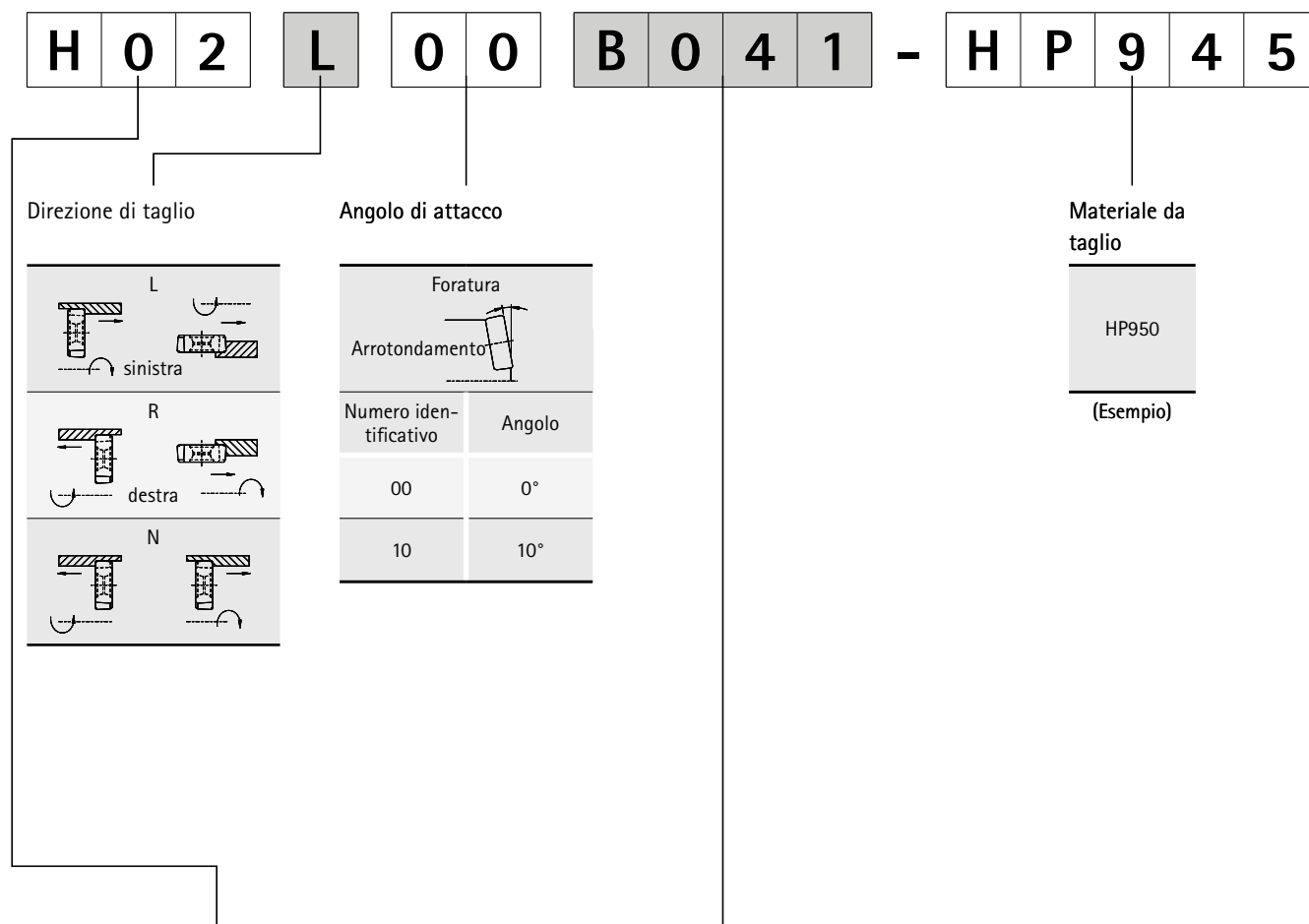

Foratura

Arrotondamento

Numero identificativo	Angolo
00	0°
10	10°

A diagram of a drill bit with a chamfered edge, labeled 'Arrotondamento'.

Materiale da taglio

HP950

(Esempio)

Gradino di convogliamento dei trucioli

Lettera identificativa
A 01...99
D 01...99
G 01...99
H 01...99







Arrotondamento

A diagram showing a chamfered edge on a cylindrical part.

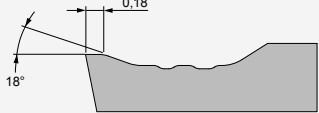
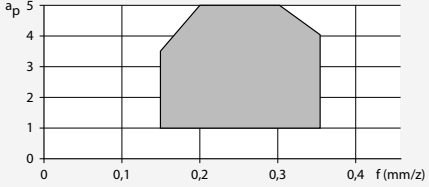
Posizione di montaggio	Numero identificativo	Raggio	CTHQ/FTHQ
	B012	12	
	B016	16	
	B021	21	
	B041	40	
	B081	80	

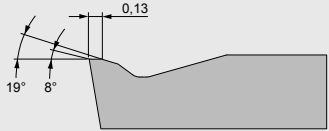
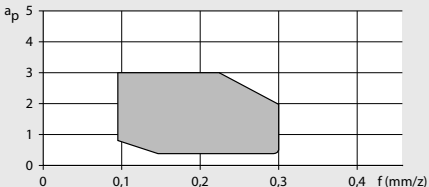
Panoramica gradini di convoglio dei trucioli - Barenatura

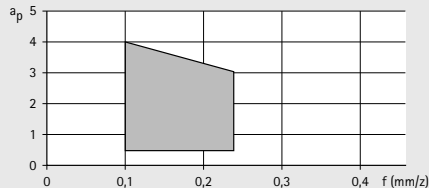
Inserto a fissaggio radiale

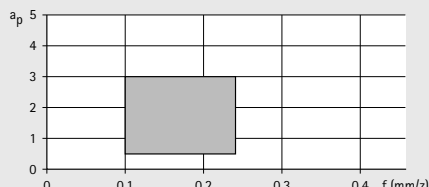



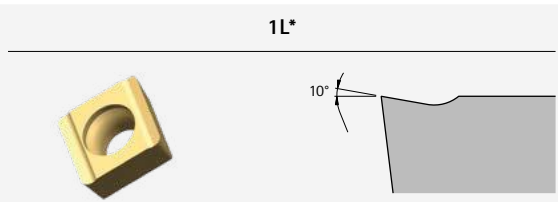
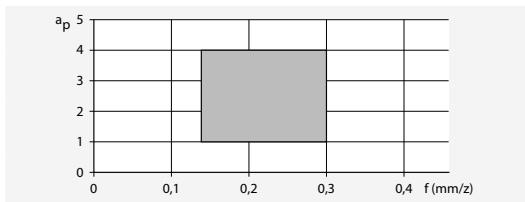
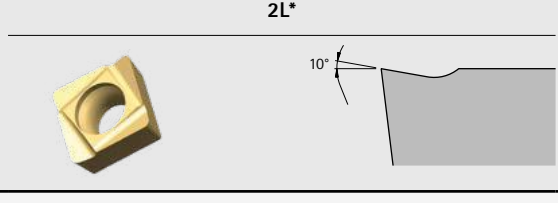
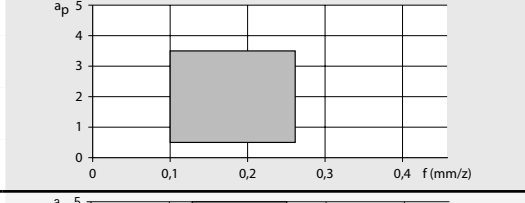
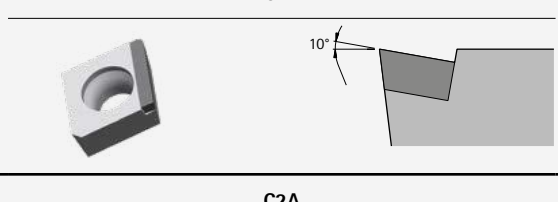
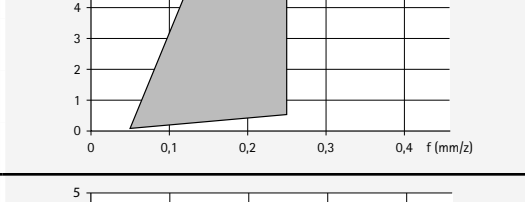
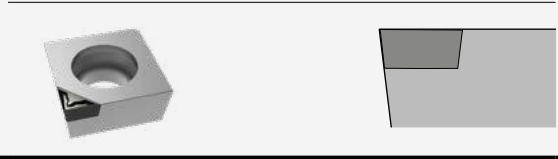
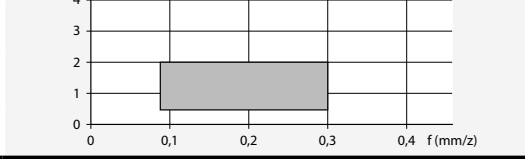
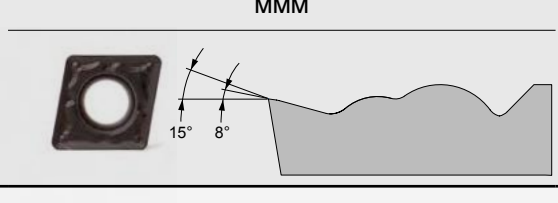
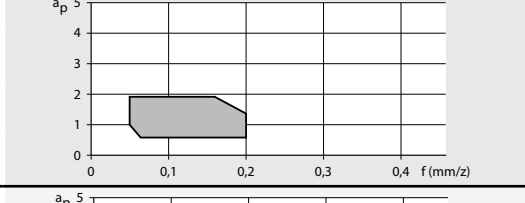
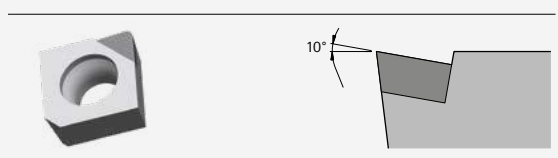
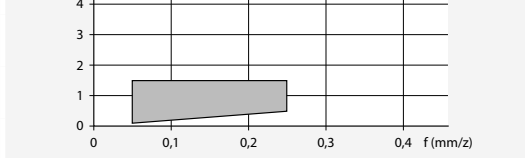
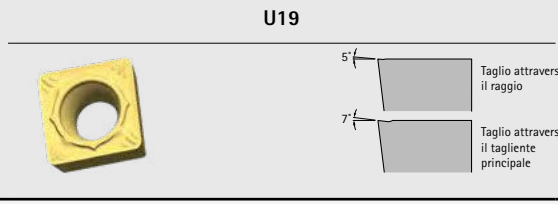
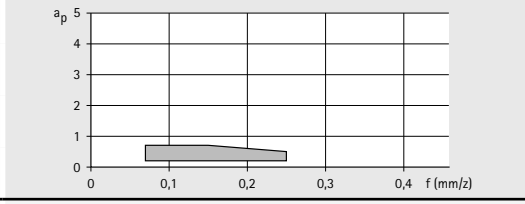
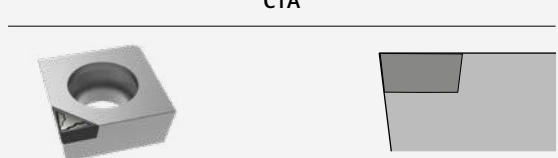
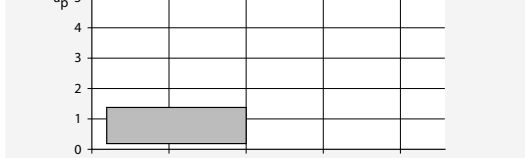



	Tipo	Categoria di materiali	Arrotondamento dei bordi	Diagramma
Sgrossatura	MKM  	P M K N	+++	
	MGP  	P M K N	++	
Lavorazione media	OA*  	P M K N	+ ++	
	OAA*  	P M K N	0 + ++	

* Questo gradino di convoglio dei trucioli è disponibile con diversi arrotondamenti dei taglienti.
 0 = spigolo vivo | + = leggermente arrotondato | ++ = mediamente arrotondato | +++ = fortemente arrotondato

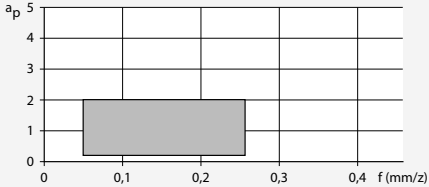
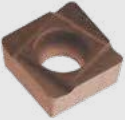
	Typo	Categoria di materiali	Arrottamento dei bordi	Diagramma
Lavorazione media	1L* 	P M K N	+ ++	
	2L* 	P M K N	+ ++	
	6LA 	P M K N	0	
	C2A 	P M K N	0	
Finitura	MMM 	P M K N	++	
	5LA 	P M K N	0	
	U19  <p>Taglio attraverso il raggio Taglio attraverso il tagliente principale</p>	P M K N	+	
	C1A 	P M K N	0	

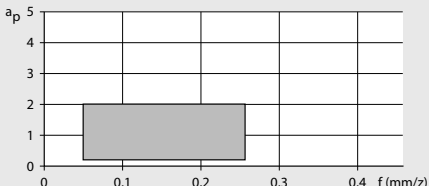
Panoramica gradini di convoglio dei trucioli - Barenatura

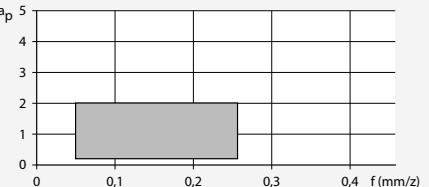
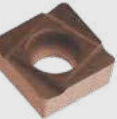
Inserto a fissaggio radiale

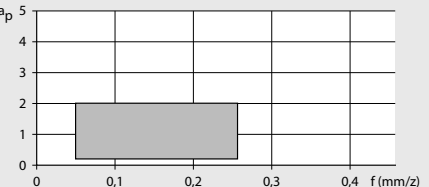
		Tipo	Categoria di materiali	Arrotondamento dei bordi	Diagramma
Lavorazione mista	1R*	 	P M K N	0 +	
	2R*	 	P M K N	0 +	
	1W	 	P M K N	+	
	2W	 	P M K N	+	

Contrassegni per inserto a fissaggio meccanico pressati "press-to-size"



* Questo gradino di convoglio dei trucioli è disponibile con diversi arrotondamenti dei taglienti.
 0 = spigolo vivo | + = leggermente arrotondato | ++ = mediamente arrotondato | +++ = fortemente arrotondato

Appunti

Panoramica gradini di convoglio dei trucioli - Barenatura

Inseri a fissaggio tangenziale

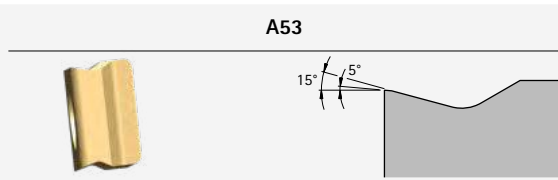
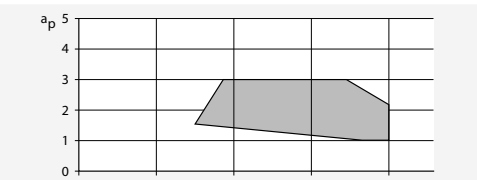
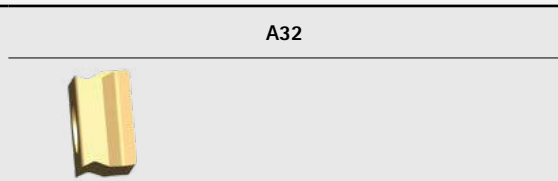
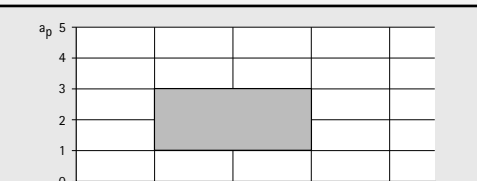
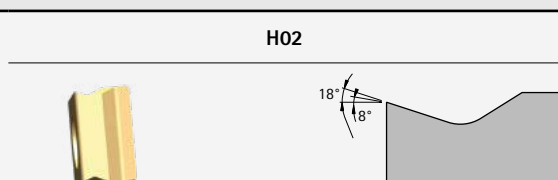
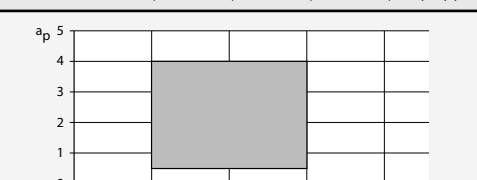
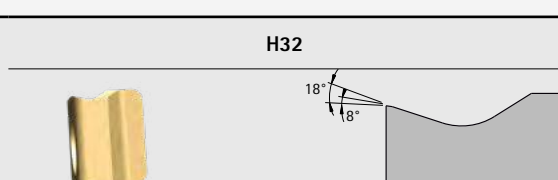
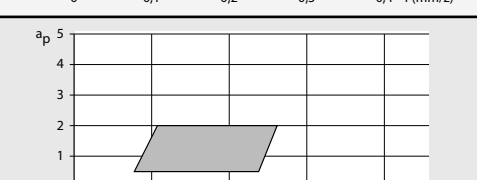
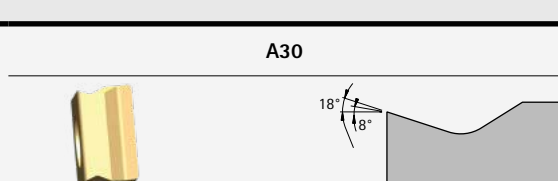
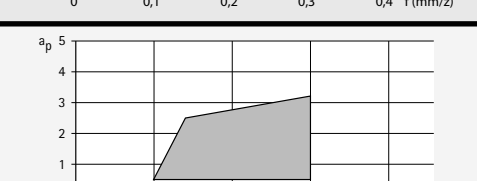
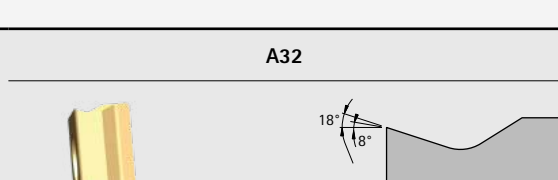
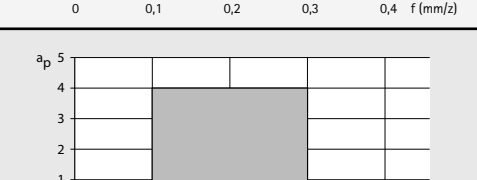
	Tipo	Categoria di materiali	Arrottamento dei bordi	Diagramma
Sgrossatura	A53 	P M K N	++	
	A32 	P M K N	++	
	H02 	P M K N	++	
	H32 	P M K K	++	
Lavorazione media	A30 	P M K N	0	
	A32 	P M K N	++	

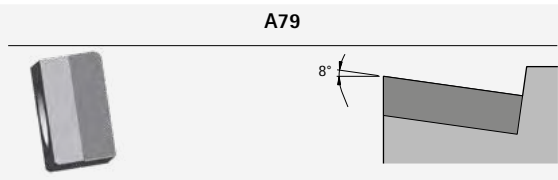
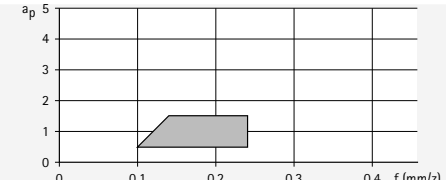
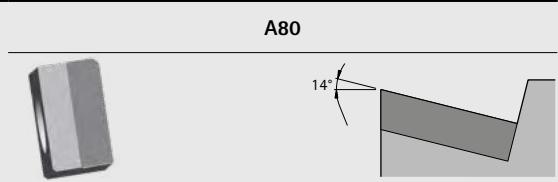
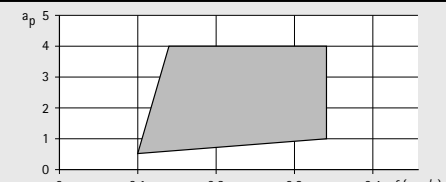
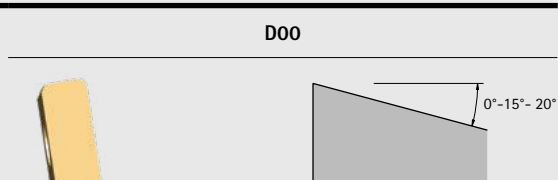
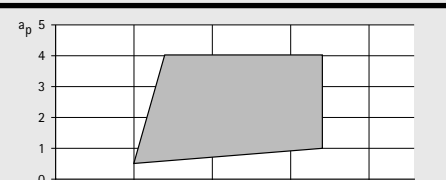
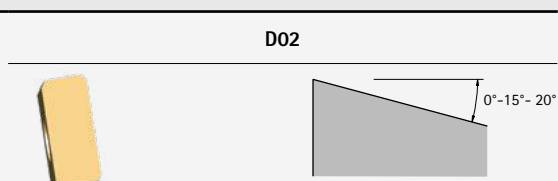
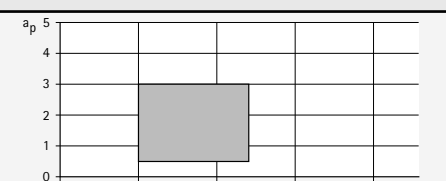
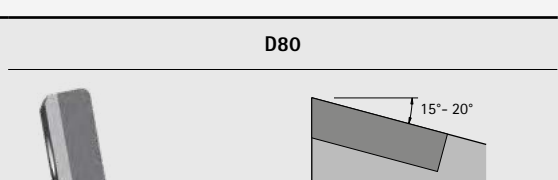
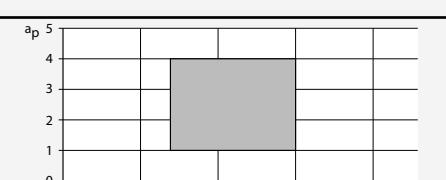
	Tipo	Categoria di materiali	Arrottamento dei bordi	Diagramma
Lavorazione media	A79 	P M K N	0	
	A80 	P M K N	0	
Universale	D00 	P M K N	0	
	D02 	P M K N	++	
	D80 	P M K N	0	

CCMT

Inserto a fissaggio radiale,
due taglienti, versione neutra



Materiale	P				
	non legato ← resistente all'usura		legato → tenace	non legato ← resistente all'usura	legato → tenace
Substrato	Metallo duro				
Rivestimento	CVD			PVD	
Tipo di materiale da taglio	HC850	HC855	HC865	HP880	HP895

Versione dei bordi di taglio		MKM		MKM			
CCMT06	a_p max. [mm]						
Sgrossatura	CCMT060204N-...-	1,5 - 2,5					
	CCMT09						
	CCMT09T304N-...-	1,5 - 3,0			30966062		
		1,5 - 4,0					
	CCMT09T308N-...-	1,5 - 3,0	31265843		30985462		
		1,5 - 4,0					
	CCMT12						
	CCMT120408N-...-	1,5 - 4,0	31265844		30985477		
		1,5 - 5,0					
	CCMT120412N-...-	1,5 - 4,0	31265846		30985485		
1,5 - 5,0							

Versione dei bordi di taglio		MGP	MGP	MGP	MGP	MGP	
CCMT06	a_p max. [mm]						
Lavorazione media	CCMT060202N-...-...	0,25 - 2,0					
	CCMT060204N-...-...	0,5 - 2,0		30985423		30985422	
	CCMT060208N-...-...	0,75 - 2,0	30985443			30985442	
	CCMT09						
	CCMT09T302N-...-...	0,25 - 3,0	30985451				
	CCMT09T304N-...-...	0,5 - 3,0		30985455	31092654	30966057	30966058
	CCMT09T308N-...-...	0,75 - 3,0	31265842	30985892	30985461	30985891	30985460
	CCMT12						
	CCMT120404N-...-...	0,5 - 3,0	30985470				
	CCMT120408N-...-...	0,75 - 3,0	30985473		30985474		
CCMT120412N-...-...	1,0 - 3,0	31265845		31092655			

Versione dei bordi di taglio		MMM		MMM	MMM	MMM	
CCMT06	a_p max. [mm]						
Finitura	CCMT060202N-...-...	0,5 - 1,0	30985415			30985414	
	CCMT060204N-...-...	0,5 - 1,0	30985435		30985436	30985432	30985433
	CCMT060208N-...-...	0,5 - 1,0					30985448
	CCMT09						
	CCMT09T302N-...-...	0,5 - 1,0	30985453				30985452
	CCMT09T304N-...-...	0,5 - 1,0	30985887		30966053	30966070	30955706
	CCMT09T308N-...-...	0,5 - 1,0	30985465		30985896	30985894	30985895

M					K			
austenitico ← resistente all'usura		ferritico → tenace	austenitico ← resistente all'usura		ferritico → tenace	GJL ← resistente all'usura		GJS → tenace
Metallo duro					Metallo duro			
CVD		PVD			CVD			
HC875	HC885	HP880	HP885	HP895	HC820	HC830		
					MKM	MKM		
					30985425	30985427		
					30966120	30985884		
					30966113	30985893		
					30985475	30985476		
					30985481	30985483		
	MGP	MGP	MGP	MGP	MGP	MGP		
	30985420	30985421		31245556	30985422	30985413	30985419	
				31245557	30985442	30985439	30985441	
						30985450		
	30985883	30966056	30966057	31245558	30966058	30985882	30985454	
	30985459	30985890	30985891	31245559	30985460	30985888	30985889	
						30985467	30985469	
	30985899					30985472	30985898	
						30985479		
			MMM	MMM	MMM	MMM	MMM	
					30985414			
			30985432	31245539	30985433	30985429	30985431	
				31245541	30985448	30985445	30985447	
					30985452			
			30966070	31245543	30955706	30985885	30985886	
			30985894	31245545	30985895	30985463	30985464	

CCGT

Inserto a fissaggio radiale, due taglienti, versione neutra



Metallo duro/Cermet

Varianti rivestita, a un tagliente:

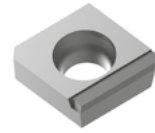

6LA

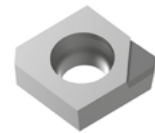

5LA



C1A



C2A

Materiale	P		M	N		
	Cermet	Metallo duro	Metallo duro	Al leg. resistente all'usura		
Substrato	Cermet	Metallo duro	Metallo duro	PCD		
Rivestimento	CVD	PVD	PVD	-		
Tipo di materiale da taglio	CC112	HP895	HP895	PU617	PU660	PU670

Versione dei bordi di taglio			MGP	MGP	6LA		C2A
CCGT06		a_p max. [mm]					
Lavorazione media	CCGT060202N-...-...	0,25 - 2,0		30985376	30985376		
	CCGT060204F01L-...-...	0,1 - 3,0			30708850		
	CCGT060204F01R-...-...	0,1 - 3,0			31277722		
	CCGT060204N-...-...	0,5 - 2,0		30985378	30985378		
	CCGT060208F01L-...-...	0,1 - 3,0			30375239		
	CCGT060208F01R-...-...	0,1 - 3,0			31204099		
	CCGT060208N-...-...	0,75 - 2,0		30985393	30985393		
	CCGT09						
	CCGT09T302N-...-...	0,25 - 3,0		30985398	30985398		
	CCGT09T304F01L-...-...	0,1 - 4,5			30370125		
	CCGT09T304F01R-...-...	0,1 - 4,5			30497774		
	CCGT09T304F01N-...-...	0,4 - 1,6					30234061
	CCGT09T304N-...-...	0,5 - 3,0		30985400	30985400		
	CCGT09T308F01L-...-...	0,1 - 4,5			30370124		
	CCGT09T308F01R-...-...	0,1 - 4,5			30370397		
	CCGT09T308F01N-...-...	0,5 - 2,0					30234062
	CCGT09T308N-...-...	0,75 - 3,0		30985406	30985406		
	CCGT12						
	CCGT120404N-...-...	0,5 - 3,0		30985410	30985410		
CCGT120404F01L-...-...	0,1 - 7,0			31025433			
CCGT120408N-...-...	0,5 - 3,0		30985411	30985411			
CCGT120408F01L-...-...	0,1 - 7,0			30589862			

Versione dei bordi di taglio			U19		5LA	C1A	
CCGT06		a_p max. [mm]					
Finitura	CCGT060204N-...-...	0,1 - 0,5	30874908				
	CCGT060204F01N-...-...	0,1 - 1,0			30708851	10104313	
	CCGT060208N-...-...	0,2 - 0,5	30799422				
	CCGT060208F01N-...-...	0,1 - 1,5			31277724		
	CCGT09						
	CCGT09T304F01N-...-...	0,1 - 2,0			31079089		
	CCGT09T304F01N-...-...	0,1 - 1,0				10099042	
	CCGT09T308F01N-...-...	0,1 - 2,0			31277725		
CCGT09T308F01N-...-...	0,15 - 1,4				30234050		

CCGW

Inserti a fissaggio radiale, due taglienti,
versione neutra

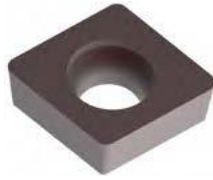

Variante rivestita,
a un tagliente:

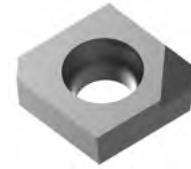

OAA

Materiale	K			N		
		GJL ← resistente all'usura	GJS → tenace	GJL ← resistente all'usura	GJS → tenace	GJL ← resistente all'usura
Substrato	Metallo duro			PcBN	PCD	
Rivestimento	CVD			PVD	-	
Tipo di materiale da taglio	HC740			HP930	FU430	

Versione dei bordi di taglio		OA	OA	OAA		
CCGW06 a_p max. [mm]						
Lavorazione media	CCGW060204E04N-...-...	0,5 - 3,2	31317178	30950259		
	CCGW060204T51N-...-...	0,5 - 2,0			10105523	
	CCGW060208E04N-...-...	0,5 - 3,2	31317202	30950280		
	CCGW09					
	CCGW09T304E04N-...-...	0,5 - 4,0	31027805	30950281		
	CCGW09T304T51N-...-...	0,5 - 2,5			10105636	
	CCGW09T308E04N-...-...	0,5 - 4,0	31023434	30950282		
	CCGW09T308T51N-...-...	0,5 - 2,5			10105650	
CCGW09T312E04N-...-...	0,5 - 4,0	31317207	30950283			

Versione dei bordi di taglio			OA	OAA	OAA	
CCGW06 a_p max. [mm]						
Finitura	CCGW060202F01N-...-...	0,1 - 1,0			31277730	
	CCGW060204F01N-...-...	0,1 - 1,0			30492177	
	CCGW060204E01N-...-...	0,1 - 1,0			10105520	
	CCGW060204E02N-...-...	0,2 - 1,0		30950284		
	CCGW060208E02N-...-...	0,2 - 1,0		30950285		
	CCGW09					
	CCGW09T304F01N-...-...	0,1 - 1,0				30418983
	CCGW09T304E01N-...-...	0,1 - 1,0			10105634	
	CCGW09T304E02N-...-...	0,2 - 2,0		30950286		
	CCGW09T308F01N-...-...	0,1 - 1,0				30492178
	CCGW09T308E01N-...-...	0,1 - 1,0			10105648	
	CCGW09T308E02N-...-...	0,2 - 2,0		30950287		

CCHT

Inserti a fissaggio radiale, due taglienti, versione sinistra

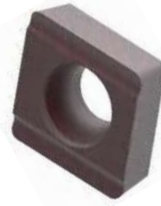

Materiale	K		N	
Substrato	Metallo duro		Metallo duro	
Rivestimento	CVD	PVD	-	PVD
Tipo di materiale da taglio	HC740	HP930	HU616	HP615

Versione dei bordi di taglio		1L	1L		1R	
CCHT06 a_p max. [mm]						
Lavorazione media	CCHT060204E04L-...-...	0,5 - 3,2	31041976	30950288		
	CCHT060208E04L-...-...	0,5 - 3,2	31115820	30950289		
	CCHT09					
	CCHT09T302F01L-...-...	0,5 - 4,0				30492197
	CCHT09T304F01L-...-...	0,5 - 4,0				30478168
	CCHT09T304E04L-...-...	0,5 - 4,0	30963744	30950290		
	CCHT09T308F01L-...-...	0,5 - 4,0				30484471
	CCHT09T308E04L-...-...	0,5 - 4,0	30884324	30950291		
	CCHT09T312E04L-...-...	0,5 - 4,0	30884469	30950292		
	CCHT12					
	CCHT120404E04L-...-...	0,5 - 5,0	30963715	30950293		
	CCHT120408E04L-...-...	0,5 - 5,0	30894700	30950294		
CCHT120412E04L-...-...	0,5 - 5,0	31317213	30950295			

Versione dei bordi di taglio			1L	1R	1R	
CCHT06 a_p max. [mm]						
Finitura	CCHT060202F01L-...-...	0,1 - 1,0		30010702		
	CCHT060204F01L-...-...	0,1 - 1,4		30010703		
	CCHT060204E02L-...-...	0,1 - 1,0		30950296		
	CCHT060208F01L-...-...	0,1 - 1,8		30010704		
	CCHT060208E02L-...-...	0,1 - 1,0		30950297		
	CCHT09					
	CCHT09T302F01L-...-...	0,1 - 2,0		30010705	30492197	
	CCHT09T304F01L-...-...	0,1 - 2,0		30010706	30478168	
	CCHT09T304E02L-...-...	0,1 - 2,0		30950298		
	CCHT09T308F01L-...-...	0,1 - 2,0		30010707	30484471	
	CCHT09T308E02L-...-...	0,1 - 2,0		30950299		
	CCHT09T312F01L-...-...	0,1 - 2,0		30084580		
	CCHT12					
	CCHT120402F01L-...-...	0,1 - 3,0		30010708		
	CCHT120404F01L-...-...	0,1 - 3,0		30010709		
CCHT120408F01L-...-...	0,1 - 3,0		30010710			
CCHT120412F01L-...-...	0,1 - 3,0		30010711			

CCHT

Inserti a fissaggio radiale, due taglienti, versione destra



Materiale	K		N	
Substrato	Metallo duro		Metallo duro	
Rivestimento	CVD	PVD	-	PVD
Tipo di materiale da taglio	HC740	HP930	HU616	HP615

Versione dei bordi di taglio		1L	1L		1R	
CCHT06 a_p max. [mm]						
Lavorazione media	CCHT060204E04R-...-...	0,5 - 3,2	31317208	30950300		
	CCHT060208E04R-...-...	0,5 - 3,2	31317209	30950301		
	CCHT09					
	CCHT09T304F01R-...-...	0,5 - 4,0				30478169
	CCHT09T304E04R-...-...	0,5 - 4,0	31115392	30950302		
	CCHT09T308F01R-...-...	0,5 - 4,0				30492211
	CCHT09T308E04R-...-...	0,5 - 4,0	31041977	30950303		
	CCHT09T312E04R-...-...	0,5 - 4,0	31317210	30950304		
	CCHT12					
	CCHT120404E04R-...-...	0,5 - 5,0	31317211	30950305		
	CCHT120408E04R-...-...	0,5 - 5,0	31317212	30950306		
	CCHT120412E04R-...-...	0,5 - 5,0	31317214	30950307		

Versione dei bordi di taglio			1L	1R	1R	
CCHT06 a_p max. [mm]						
Finitura	CCHT060202F01R-...-...	0,1 - 1,0		30010732		
	CCHT060204F01R-...-...	0,1 - 1,4		30010733		
	CCHT060204E02R-...-...	0,1 - 1,0		30950308		
	CCHT060208F01R-...-...	0,1 - 1,8		30010734		
	CCHT060208E02R-...-...	0,1 - 1,0		30950309		
	CCHT09					
	CCHT09T302F01R-...-...	0,1 - 2,0		30010735		
	CCHT09T304F01R-...-...	0,1 - 2,0		30010736	30478169	
	CCHT09T304E02R-...-...	0,1 - 2,0		30950310		
	CCHT09T308F01R-...-...	0,1 - 2,0		30010737	30492211	
	CCHT09T308E02R-...-...	0,1 - 2,0		30950311		
	CCHT09T312F01R-...-...	0,1 - 2,0		30492212		
	CCHT12					
	CCHT120402F01R-...-...	0,1 - 3,0		30010738		
	CCHT120404F01R-...-...	0,1 - 3,0		30010739		
	CCHT120408F01R-...-...	0,1 - 3,0		30010740		
	CCHT120412F01R-...-...	0,1 - 3,0		30010741		

DCMT | DCGT | DCGW

Inserto a fissaggio radiale, due taglienti, versione neutra



Materiale	P				
	← non legato resistente all'usura		legato tenace →	← non legato resistente all'usura	
Substrato	Metallo duro				
Rivestimento	CVD			PVD	
Tipo di materiale da taglio	HC850	HC855	HC865	HP880	HP895

Versione dei bordi di taglio				MKM		
DCMT11		a_p max. [mm]				
Sgrossatura	DCMT11T304N-...-...	1,5 - 2,5		30966087		
		1,5 - 3,0				
	DCMT11T308N-...-...	1,5 - 3,0		30966078		
		1,5 - 4,0				

Versione dei bordi di taglio		MGP	MGP	MGP	MGP	MGP	
DCMT07		a_p max. [mm]					
Lavorazione media	DCMT070202N-...-...	0,25 - 1,8					
	DCMT070204N-...-...	0,5 - 2,0	30985499			30985498	
	DCMT070208N-...-...	0,75 - 2,0		31092658			
	DCMT11						
	DCMT11T304N-...-...	0,25 - 2,0	31092656	30985510	30966101	30966092	30966093
	DCMT11T308N-...-...	0,5 - 2,5	30966103	30985518		30966082	30966083
	DCGT11						
	DCGT11T304F01N-...-...	0,4 - 1,5					
	DCGT11T308F01N-...-...	0,5 - 1,8					
	DCMT15						
DCMT150404N-...-...	0,5 - 2,5						
DCMT150408N-...-...	0,5 - 3,0						
DCMT150412N-...-...	0,5 - 3,0						

Versione dei bordi di taglio		MMM		MMM	MMM	MMM	
DCMT07		a_p max. [mm]					
Finitura	DCMT070202N-...-...	0,5 - 1,0		30985495		30985494	
	DCMT070204N-...-...	0,5 - 1,0	30986033			30985500	
	DCMT070208N-...-...	0,5 - 1,0					
	DCMT11						
	DCMT11T302N-...-...	0,5 - 1,5	30966100			30985505	
	DCMT11T304N-...-...	0,5 - 1,5	30985902	30966088	30966095	30966096	
	DCMT11T308N-...-...	0,5 - 1,5	30966104	30966079	30966085	30966086	
	DCGT11						
	DCGT11T304F01N-...-...	0,1 - 1,0					
	DCGT11T308F01N-...-...	0,15 - 1,4					
	DCGW11						
	DCGW11T304F01N-...-...	0,1 - 2,0					
	DCGW11T304E01N-...-...	0,1 - 1,0					
	DCGW11T308F01N-...-...	0,1 - 2,0					
DCGW11T308F01N-...-...	0,1 - 1,0						

Variante rivestita,
a un tagliente:

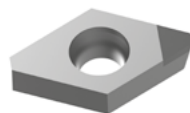

0AA



C1A



C2A

M					K			N				
austenitico resistente all'usura		ferritico tenace	austenitico resistente all'usura		ferritico tenace	GJL resistente all'usura		GJS tenace	Al leg. resistente all'usura		Cu leg. tenace	
Metallo duro					Metallo duro		PcBN	PCD				
CVD		PVD			CVD		-	-				
HC875	HC885	HP880	HP885	HP895	HC815	HC825	FU430	PU617	PU660	PU670		
					MKM	MKM						
					30985511	30985512						
					30985519	30985520						
MGP		MGP	MGP	MGP	MGP	MGP	MGP	C2A				
					30985493							
					30985498	30985496	30985497					
					30985501	30985502						
30985508	30966091	30966092	31245560	30966093	30985506	30985507						
30985517		30966082	31245562	30966083	30985515	30985516						
										30234066		
										30234067		
					30985522							
					30985523							
					30985524							
MMM		MMM			MMM	MMM	OAA	OAA	1CA			
30966105					30985494							
30966107			31245546	30985500								
					31245547							
					30985505							
		30966095	31245548	30966096	30985513							
30985903		30966085	31245549	30966086								
										30234052		
										30234053		
										31212079		
										10105921		
										31277726		
										10105952		

SCMT | SPMT | SCGT | SPGT

Inserto a fissaggio radiale,
quattro taglienti, versione neutra



Materiale	P					
		non legato resistente all'usura		legato tenace	non legato resistente all'usura	legato tenace
Substrato	Cermet	Metallo duro				
Rivestimento	CVD		CVD		PVD	
Tipo di materiale da taglio	CC112	HC850	HC855	HC865	HP880	HP895

Versione dei bordi di taglio			MKM		MKM		
SCMT09		a_p max. [mm]					
Sgrossatura	SCMT09T308N-...-...	1,5 - 3,0	31265847		30966072		
		1,5 - 4,0					
	SCMT12	1,5 - 4,0	31265848		30985564		
		1,5 - 5,0					
SCMT120412N-...-...	1,5 - 4,0	31265849					
	1,5 - 5,0						

Versione dei bordi di taglio			MGP	MGP	MGP		MGP	
SPMT06		a_p max. [mm]						
Lavorazione media	SPMT060304N-...-...	0,5 - 2,0	30985573		30985575			
	SPMT060308N-...-...	0,75 - 2,0			31265851			
	SCMT09	SCMT09T304N-...-...	0,5 - 3,0	31085129		31085141		30985536
		SCMT09T308N-...-...	0,75 - 3,0	31085140	30985543	30966127		
	SCMT09T312N-...-...	1 - 3,0	31276723		31273621			
	SCGT09	SCGT09T308F01N-...-...	0,5 - 2,0					
	SCMT12	SCMT120404N-...-...	0,5 - 3,0					
		SCMT120408N-...-...	0,75 - 3,0	31085142	30985560	31085143		

Versione dei bordi di taglio			U19	MMM	MMM	MMM	MMM		
SPMT06		a_p max. [mm]							
Finitura	SPMT060304N-...-...	0,5 - 2,0		30985579		30985580	30985577	30985913	
	SPGT06	SPGT060304F01N-...-...	0,1 - 0,8						
		SPGT060304F01L-...-...	0,1 - 3,0						
		SPGT060304F01R-...-...	0,1 - 3,0						
		SPGT060308F01N-...-...	0,1 - 0,8						
		SPGT060308F01L-...-...	0,1 - 3,0						
		SPGT060308F01R-...-...	0,1 - 3,0						
		SCMT09	SCMT09T304N-...-...	0,5 - 1,5		31085144		31085145	30985540
	SCMT09T308N-...-...	0,5 - 1,5		30983531		30966073	30966076	30955704	
	SCGT09	SCGT09T304N-...-...	0,1 - 0,5	30647885					
		SCGT09T304F01N-...-...	0,1 - 0,5						
		SCGT09T304F01L-...-...	0,1 - 4,5						
		SCGT09T304F01R-...-...	0,1 - 4,5						
		SCGT09T308N-...-...	0,1 - 0,5	10102893					
		SCGT09T308F01N-...-...	0,1 - 0,5						
		SCGT09T308F01N-...-...	0,15 - 1,4						
		SCGT09T308F01L-...-...	0,1 - 4,5						
		SCGT09T308F01R-...-...	0,1 - 4,5						

I campi a_p indicati sono raccomandazioni e possono variare in funzione del materiale lavorato.

Varianti rivestita,
a un tagliante:

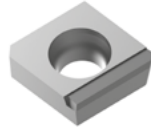

6LA

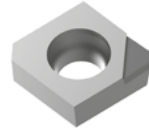

5LA



C1A



C2A

M				K		N									
austenitico resistente all'usura		ferritico tenace		austenitico resistente all'usura		ferritico tenace		GJL resistente all'usura		GJS tenace		Al leg. resistente all'usura		Cu leg. tenace	
Metallo duro						PCD									
CVD		PVD													
HC875	HC885	HP880	HP895	HC820	HC830	PU617	PU660	PU670							
				MKM	MKM										
									30985545	31092659					
									30985562	31092660					
									30985566	31092661					
	MGP			MGP	MGP	MGP									C2A
									30985574	30985576					
									30985914	30985915					
	30985535			30985536	30985908	30985534									
	31092662				30985911	30985912									
															30249457
	30985559				30985552	30985554			30985556	30985558					
		MMM	MMM	MMM	MMM	MMM	5LA	6LA	C1A						
		30972033	30985577	30985913	30985578	31084646									
											31277727				
												30373268			
												31279699			
											31279698				
												31217111			
												31279720			
				30985540	30985538	30985539									
			30966076	30955704	30985548	30985550									
											30374908				
												30546951			
												31279721			
											30692832				
														30250261	
												30568596			
												31279723			

SCGW | SPGW

Inseri a fissaggio radiale, quattro taglienti

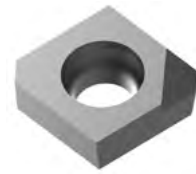

Variante rivestita,
a un tagliente:

OAA

Materiale	K			N		
		GJL ← resistente all'usura	GJS → tenace	GJL ← resistente all'usura	GJS → tenace	GJL ← resistente all'usura
Substrato	Metallo duro			PcBN		PCD
Rivestimento	CVD		PVD		-	
Tipo di materiale da taglio	HC740		HP930		FU430	

Versione dei bordi di taglio		OA	OA	OAA	
SPGW06 a_p max. [mm]					
Lavorazione media	SPGW060304E04N-...-...	0,5 - 3,2	31070945	30950312	
	SPGW060308E04N-...-...	0,5 - 3,2	31050739	30950313	
	SCGW09				
	SCGW09T304E04N-...-...	0,5 - 4,0	31022296	30950314	
	SCGW09T304T51N-...-...	0,5 - 2,5			10106285
	SCGW09T308E04N-...-...	0,5 - 4,0	31022297	30950315	
	SCGW09T308T51N-...-...	0,5 - 2,5			10106299
	SCGW12				
	SCGW120404E04N-...-...	0,5 - 5,0	31317220	30950316	
	SCGW120408E04N-...-...	0,5 - 5,0	30939413	30950317	

Versione dei bordi di taglio		OA	OAA	OAA	
SPGW06 a_p max. [mm]					
Finitura	SPGW060304F01N-...-...	0,1 - 1,2		31277731	
	SPGW060304E02N-...-...	0,2 - 1,0	30950318		
	SPGW060308F01N-...-...	0,1 - 1,0		31279738	
	SPGW060308E02N-...-...	0,2 - 1,0	30950319		
	SCGW09				
	SCGW09T304F01N-...-...	0,1 - 1,4			31277732
	SCGW09T304E01N-...-...	0,1 - 1,0		10106283	
	SCGW09T304E02N-...-...	0,2 - 2,0	30950320		
	SCGW09T308F01N-...-...	0,1 - 1,8			30429723
	SCGW09T308E01N-...-...	0,1 - 1,0		10106297	
	SCGW09T308E02N-...-...	0,2 - 2,0	30950321		
	SCGW12				
	SCGW120404F01N-...-...	0,1 - 1,4			31279752
	SCGW120408F01N-...-...	0,1 - 1,8			31279753

SCHT | SPHT

Inseri a fissaggio radiale, due taglienti, versione neutra



Materiale	K		N	
	GJL ← resistente all'usura	GJS → tenace	GJL ← resistente all'usura	GJS → tenace
Substrato	Metallo duro			Metallo duro
Rivestimento	CVD		PVD	
Tipo di materiale da taglio	HC740		HP930	

Versione dei bordi di taglio		1L	1L		
SPHT06 a_p max. [mm]					
Lavorazione media	SPHT060304E04X-...-...	0,5 - 3,2	31042317	30953122	
	SPHT060308E04X-...-...	0,5 - 3,2	31317315	30953126	
	SCHT09				
	SCHT09T304E04X-...-...	0,5 - 4,0	31121604	30953127	
	SCHT09T308E04X-...-...	0,5 - 4,0	30963756	30953128	
	SCHT09T312E04X-...-...	0,5 - 4,0	31317219	30953150	
	SCHT12				
	SCHT120404E04X-...-...	0,5 - 5,0	31081857	30953151	
	SCHT120408E04X-...-...	0,5 - 5,0	31317304	30953152	
	SCHT120412E04X-...-...	0,5 - 5,0	31317308	30953154	

Versione dei bordi di taglio			1L	1R	
SPHT06 a_p max. [mm]					
Finitura	SPHT060304E02X-...-...	0,1 - 1,0		30953158	
	SPHT060308E02X-...-...	0,1 - 1,0		30953164	
	SCHT09				
	SCHT09T302F01X-...-...	0,1 - 2,0			30141062
	SCHT09T304F01X-...-...	0,1 - 2,0			30010681
	SCHT09T304E02X-...-...	0,1 - 2,0		30953159	
	SCHT09T308F01X-...-...	0,1 - 2,0			30010682
	SCHT09T308E02X-...-...	0,1 - 2,0		30953168	
	SCHT09T312F01X-...-...	0,1 - 2,0			30492274
	SCHT12				
SCHT120404F01X-...-...	0,1 - 3,0			30010683	
SCHT120408F01X-...-...	0,1 - 3,0			30010684	

SCHT | SPHT

Inserti a fissaggio radiale, quattro taglienti



versione sinistra



versione destra

Materiale	K		N	
	GJL ← resistente all'usura	GJS → tenace	GJL ← resistente all'usura	GJS → tenace
Substrato	Metallo duro		Metallo duro	
Rivestimento	CVD		-	PVD
Tipo di materiale da taglio	HC740		HU616	HP615

Versione dei bordi di taglio		2L	2L		2R	
SPHT06		<i>a_p max. [mm]</i>				
Lavorazione media	SPHT060302F01L-...-...	0,5 - 3,2			30492231	
	SPHT060302F01R-...-...	0,5 - 3,2			30492248	
	SPHT060304F01L-...-...	0,5 - 3,2			30239958	
	SPHT060304F01R-...-...	0,5 - 3,2			30492249	
	SPHT060304E04L-...-...	0,5 - 3,2	31044035	30950322		
	SPHT060304E04R-...-...	0,5 - 3,2	30939004	30950346		
	SPHT060308F01L-...-...	0,5 - 3,2			30492232	
	SPHT060308F01R-...-...	0,5 - 3,2			30492250	
	SPHT060308E04L-...-...	0,5 - 3,2	31317311	30950323		
	SPHT060308E04R-...-...	0,5 - 3,2	31317314	30950347		
	SCHT09					
	SCHT09T304F01L-...-...	0,5 - 4,0			30492235	
	SCHT09T304F01R-...-...	0,5 - 4,0			30492252	
	SCHT09T304E04L-...-...	0,5 - 4,0	31043583	30950324		
	SCHT09T304E04R-...-...	0,5 - 4,0	30812298	30950348		
	SCHT09T308F01L-...-...	0,5 - 4,0			30042582	
	SCHT09T308F01R-...-...	0,5 - 4,0			30492253	
	SCHT09T308E04L-...-...	0,5 - 4,0	31039585	30950325		
	SCHT09T308E04R-...-...	0,5 - 4,0	31317215	30950349		
	SCHT09T312E04L-...-...	0,5 - 4,0	31317216	30950326		
SCHT09T312E04R-...-...	0,5 - 4,0	31317217	30950350			
SCHT12						
SCHT120404E04L-...-...	0,5 - 5,0	31317284	30950327			
SCHT120404E04R-...-...	0,5 - 5,0	31317287	30950351			
SCHT120408E04L-...-...	0,5 - 5,0	31317300	30950328			
SCHT120408E04R-...-...	0,5 - 5,0	31317301	30950352			
SCHT120412E04L-...-...	0,5 - 5,0	31317305	30950329			
SCHT120412E04R-...-...	0,5 - 5,0	31317307	30950353			

Tabella seguente:
Finitura



SCHT | SPHT

Inserti a fissaggio radiale, quattro taglienti



versione sinistra



versione destra

Materiale	K	N	
		Al leg. ← resistente all'usura	Cu leg. → tenace
Substrato		Metallo duro	
Rivestimento	PVD	-	PVD
Tipo di materiale da taglio	HP930	HU616	HP615

Versione dei bordi di taglio		2L	2R	2R	
SPHT06					
	a_p max. [mm]				
Finitura	SPHT060302F01L-...-...	0,1 - 1,0	30092077	30492231	
	SPHT060302F01R-...-...	0,1 - 1,0	30089678	30492248	
	SPHT060304F01L-...-...	0,1 - 1,0	30010644	30239958	
	SPHT060304F01R-...-...	0,1 - 1,0	30010662	30492249	
	SPHT060304E02L-...-...	0,1 - 1,0	30950330		
	SPHT060304E02R-...-...	0,1 - 1,0	30950354		
	SPHT060308F01L-...-...	0,1 - 1,0	30057636	30492232	
	SPHT060308F01R-...-...	0,1 - 1,0	30438143	30492250	
	SPHT060308E02L-...-...	0,1 - 1,0	30950331		
	SPHT060308E02R-...-...	0,1 - 1,0	30950355		
	SCHT09				
	SCHT09T304F01L-...-...	0,1 - 2,0		30010645	30492235
	SCHT09T304F01R-...-...	0,1 - 2,0		30010663	30492252
	SCHT09T304E02L-...-...	0,1 - 2,0	30950332		
SCHT09T304E02R-...-...	0,1 - 2,0	30950356			
SCHT09T308F01L-...-...	0,1 - 2,0		30010646	30042582	
SCHT09T308F01R-...-...	0,1 - 2,0		30010664	30492253	
SCHT09T308E02L-...-...	0,1 - 2,0	30950333			
SCHT09T308E02R-...-...	0,1 - 2,0	30950357			

TCMT | TCGW

Inserto a fissaggio radiale, tre taglienti, versione neutra



Materiale	P				
	non legato ← resistente all'usura	legato → tenace	non legato ← resistente all'usura	legato → tenace	
Substrato	Metallo duro				
Rivestimento	CVD		PVD		
Tipo di materiale da taglio	HC850	HC865	HP880	HP895	
Versione dei bordi di taglio		MKM			
TCMT11	a_p max. [mm]				
Sgrossatura	TCMT110204N-...-...	1,5 - 3,0	30985591		
		1,5 - 4,0			
	TCMT16				
	TCMT16T304N-...-...	1,5 - 3,0	30985608		
		1,5 - 5,0			
		1,5 - 3,0	30985615		
		1,5 - 5,0			
Versione dei bordi di taglio		MGP	MGP	MGP	
TCMT09	a_p max. [mm]				
Lavorazione media	TCMT090204N-...-...	0,5 - 2,0	30985582		
	TCMT11				
	TCMT110204N-...-...	0,5 - 2,5	30945048	30985589	30985588
	TCMT110208N-...-...	0,75 - 2,5	30985599	30985600	30985601
	TCGW11				
	TCGW110204T51N-...-...	0,5 - 2,5			
	TCGW110208T51N-...-...	0,75 - 2,5			
	TCMT16				
	TCMT16T304N-...-...	0,5 - 2,5	30985605	31092663	30985604
	TCMT16T308N-...-...	0,75 - 2,5	30985613	31092665	30985612
TCMT16T312N-...-...	1,0 - 2,5		31092666		
TCMT22					
TCMT220408N-...-...	0,75 - 3,0				
Versione dei bordi di taglio		MMM	MMM	MMM	
TCMT11	a_p max. [mm]				
Finitura	TCMT110202N-...-...	0,5 - 1,5	30985584	30985585	30985583
	TCMT110204N-...-...	0,5 - 1,5	30985595	30985596	30985594
	TCMT110208N-...-...	0,5 - 1,5		30985593	
	TCGW11				
	TCGW110204F01N-...-...	0,1 - 1,0			
	TCGW110204E01N-...-...	0,1 - 1,0			
	TCGW110208F01N-...-...	0,1 - 1,5			
	TCGW110208E01N-...-...	0,1 - 1,0			
TCMT16					
TCMT16T304N-...-...	0,5 - 1,5			30985609	
TCMT16T308N-...-...	0,5 - 1,5			30985617	



Variante rivestita,
a un tagliente:

OAA

M				K			N	
austenitico ← resistente all'usura				ferritico → tenace	GJL ← resistente all'usura	GJS → tenace		
Metallo duro				Metallo duro		PcBN	PCD	
CVD		PVD		CVD		-	-	
HC875	HP880	HP885	HP895	HC815	HC825	FU430	PU617	
				MKM				
				30985590				
				30985607				
				30985614				
	MGP		MGP	MGP	MGP	OAA		
				30985917				
30985587			30985588	30985586				
30985598		31245563	30985601	30985597				
						30227880		
						30227892		
			30985604	30985602	30985603			
			30985612	30985610	30985611			
		31245564		30985618	30985619			
				30985622	30985623			
	MMM	MMM	MMM	MMM	MMM	OAA	OAA	
			30985583					
	30985593	31245550	30985594	30985592				
		31245551						
							31279724	
						30227878		
						30227890		31279725
		31245552	30985609					
30985616		31245553	30985617					

TCHT

Inserti a fissaggio radiale, tre taglienti, versione sinistra/destra

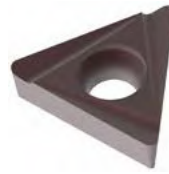

versione sinistra

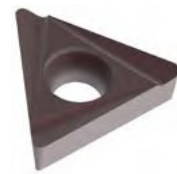

versione destra

Materiale	K		N
	Metallo duro		Metallo duro
Substrato	Metallo duro		Metallo duro
Rivestimento	CVD	PVD	
Tipo di materiale da taglio	HC740	HP930	HU616

Versione dei bordi di taglio		2L	2L		
TCHT09 a_p max. [mm]					
Lavorazione media	TCHT090204E04L-...-...	0,5 - 2,5	31317317	30950224	
	TCHT090204E04R-...-...	0,5 - 2,5	31317318	30950235	
	TCHT090208E04L-...-...	0,5 - 2,5	31317319	30950225	
	TCHT090208E04R-...-...	0,5 - 2,5	31317320	30950236	
	TCHT11				
	TCHT110204E04L-...-...	0,5 - 3,0	31317321	30950226	
	TCHT110204E04R-...-...	0,5 - 3,0	31317322	30950237	
	TCHT110208E04L-...-...	0,5 - 3,0	31317325	30950227	
	TCHT110208E04R-...-...	0,5 - 3,0	31317326	30950238	
	TCHT16				
	TCHT16T304E04L-...-...	0,5 - 4,0	31317327	30950228	
	TCHT16T304E04R-...-...	0,5 - 4,0	31317328	30950239	
	TCHT16T308E04L-...-...	0,5 - 4,0	31317340	30950229	
	TCHT16T308E04R-...-...	0,5 - 4,0	31317342	30950240	

Versione dei bordi di taglio			2L	2R	
TCHT06 a_p max. [mm]					
Finitura	TCHT06T104F01L-...-...	0,1 - 1,0		30492290	
	TCHT06T104F01R-...-...	0,1 - 1,0		30492307	
	TCHT06T104E02L-...-...	0,1 - 1,0		30950230	
	TCHT06T104E02R-...-...	0,1 - 1,0		30950241	
	TCHT09				
	TCHT090204F01L-...-...	0,1 - 1,0		30010759	
	TCHT090204F01R-...-...	0,1 - 1,0		30010777	
	TCHT090204E02L-...-...	0,1 - 1,0		30950231	
	TCHT090204E02R-...-...	0,1 - 1,0		30950242	
	TCHT090208E02L-...-...	0,1 - 1,0		30950232	
	TCHT090208E02R-...-...	0,1 - 1,0		30950243	
	TCHT11				
	TCHT110202F01L-...-...	0,1 - 1,5		30010761	
	TCHT110202F01R-...-...	0,1 - 1,5		30010779	
	TCHT110204F01L-...-...	0,1 - 1,5		30010762	
	TCHT110204F01R-...-...	0,1 - 1,5		30010780	
	TCHT110204E02L-...-...	0,1 - 1,5		30950233	
	TCHT110204E02R-...-...	0,1 - 1,5		30950244	
	TCHT110208F01L-...-...	0,1 - 1,5		30010763	
	TCHT110208F01R-...-...	0,1 - 1,5		30478186	
	TCHT110208E02L-...-...	0,1 - 1,5		30950234	
	TCHT110208E02R-...-...	0,1 - 1,5		30950245	
	TCHT16				
	TCHT16T304F01L-...-...	0,1 - 2,5		30478187	
	TCHT16T304F01R-...-...	0,1 - 2,5		30478188	
	TCHT16T308F01L-...-...	0,1 - 2,5		30019882	
	TCHT16T308F01R-...-...	0,1 - 2,5		30478189	

TCHT

Inserti a fissaggio radiale, un tagliente, versione neutra

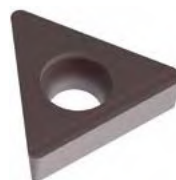

Materiale	K		N
Substrato	Metallo duro		Metallo duro
Rivestimento	CVD	PVD	
Tipo di materiale da taglio	HC740	HP930	HU616

Versione dei bordi di taglio		1L	1L	
TCHT09 a_p max. [mm]				
Lavorazione media	TCHT090204E04X-...-...	0,5 - 2,5	31319106	30950246
	TCHT090208E04X-...-...	0,5 - 2,5	31319107	30950247
	TCHT11			
	TCHT110204E04X-...-...	0,5 - 3,0	31319108	30950248
	TCHT110208E04X-...-...	0,5 - 3,0	31319109	30950249
	TCHT16			
TCHT16T304E04X-...-...	0,5 - 4,0	31039581	30950250	
TCHT16T308E04X-...-...	0,5 - 4,0	31319140	30950251	

Versione dei bordi di taglio			1L	1R
TCHT06 a_p max. [mm]				
Finitura	TCHT06T104F01X-...-...	0,1 - 1,0		30492325
	TCHT06T104E02X-...-...	0,1 - 1,0	30950252	
	TCHT09			
	TCHT090204F01X-...-...	0,1 - 1,0		30010795
	TCHT090204E02X-...-...	0,1 - 1,0	30950253	
	TCHT090208E02X-...-...	0,1 - 1,0	30950254	
	TCHT11			
	TCHT110202F01X-...-...	0,1 - 1,5		30010797
	TCHT110204F01X-...-...	0,1 - 1,5		30010798
	TCHT110204E02X-...-...	0,1 - 1,5	30950255	
	TCHT110208F01X-...-...	0,1 - 1,5		30010799
	TCHT110208E02X-...-...	0,1 - 1,5	30950256	
	TCHT16			
	TCHT16T304F01X-...-...	0,1 - 2,5		30019940
	TCHT16T308F01X-...-...	0,1 - 2,5		30019941

VCMT | VCGT | VBGW | VCGW

Inserti a fissaggio radiale, due taglienti, versione neutra



Materiale	P		
	non legato ← resistente all'usura		legato → tenace
Substrato	Metallo duro		
Rivestimento	CVD		PVD
Tipo di materiale da taglio	HC850	HC865	HP880
Versione dei bordi di taglio			
VCMT16			MKM
a_p max. [mm]			
Sgrossatura	VCMT160408N-...-...	1,5 - 3,0	30985630
Versione dei bordi di taglio			
VCGT11		MGP	MGP
a_p max. [mm]			
Lavorazione media	VCGT110304N-...-...	0,25 - 2,0	30966122
	VCMT160404N-...-...	0,5 - 2,0	30966097
			30966098
	VCMT160408N-...-...	0,75 - 2,0	31093307
			30985629
Versione dei bordi di taglio			
VBGW16			
a_p max. [mm]			
Finitura	VBGW160404E01N-...-...	0,1 - 1,0	
	VBGW160408E01N-...-...	0,1 - 1,0	
	VCGW160404E01N-...-...	0,1 - 1,0	
	VCGW160408E01N-...-...	0,1 - 1,0	



Variante rivestita,
a un tagliente:

OAA

	M	K	
	Metallo duro	Metallo duro	PcBN
	PVD	CVD	-
	HP880	HC815	FU430
	MGP	MGP	
	30966122		
		30985627	
		30985628	
			OAA
			10106686
			10106698
			10106768
			10106780

CCHT | Lavorazione mista

Inserti a fissaggio radiale, due taglienti, lavorazione mista



versione destra



versione sinistra

Materiale	N + K		N + P			
	GJL ← resistente all'usura	GJS → tenace	non legato ← resistente all'usura	legato → tenace		
Substrato	Metallo duro		Metallo duro			
Rivestimento	PVD		PVD			
Tipo di materiale da taglio	HP525-P	HP530-P	HP540-P	HP545-P		
Versione dei bordi di taglio	1W	1W	1R	1R		
CCHT09	a_p max. [mm]					
Raggio	CCHT09T304E02L-...-...	0,1 - 2,0 *	30909374	30909375	30907411	30909351
	CCHT09T304E02R-...-...	0,1 - 2,0	30909376	30909377	30909352	30909353
	CCHT09T308E02L-...-...	0,1 - 2,0	30909378	30909379	30909354	30909355
	CCHT09T308E02R-...-...	0,1 - 2,0	30909380	30909381	30909356	30909357

* A seconda del cuscinetto calibrato.
Disponibile anche per taglienti speciali.

SCHT | Lavorazione mista

Inserti a fissaggio radiale, quattro taglienti, lavorazione mista



con raggio,
versione sinistra



con raggio,
versione destra

Materiale	N + K		N + P			
	GJL ← resistente all'usura	GJS → tenace	non legato ← resistente all'usura	legato → tenace		
Substrato	Metallo duro		Metallo duro			
Rivestimento	PVD		PVD			
Tipo di materiale da taglio	HP525-P	HP530-P	HP540-P	HP545-P		
Versione dei bordi di taglio	2W	2W	2R	2R		
SCHT09	a_p max. [mm]					
Raggio	SCHT09T304E02L-...-...	0,1 - 2,0	30909366	30909367	30909345	30909346
	SCHT09T304E02R-...-...	0,1 - 2,0	30909368	30909369	30909347	30909348
	SCHT09T308E02L-...-...	0,1 - 2,0	30909370	30909371	30909349	30909350
	SCHT09T308E02R-...-...	0,1 - 2,0	30909372	30909373	30903215	30907589

CTNQ

Inserti a fissaggio tangenziale, quattro taglienti, senza arrotondamento del tagliente



Materiale	P			M ₁	
	← non legato resistente all'usura			legato tenace →	
Substrato	Metallo duro			Metallo duro	
Rivestimento	CVD	PVD		CVD	
Tipo di materiale da taglio	HC740	HP945	HP950	HC750	

Versione dei bordi di taglio		H02	H02	H02	A32	
CTNQ da ø 41 mm		a _p max. [mm]				
Sgrossatura	CTNQ090508...L-...	1,5 - 3,0	30933846	30933848	30933849	30950088
		1,5 - 4,0				
	CTNQ090508...R-...	1,5 - 3,0	30933850	30933851	30950091	30950092
		1,5 - 4,0				
	CTNQ090512...L-...	1,5 - 3,0	30933852	30933854	30933855	30950094
		1,5 - 4,0				
	CTNQ090512...R-...	1,5 - 3,0	30933856	30933857	30950097	30950099
		1,5 - 4,0				
	CTNQ da ø 54 mm					
	CTNQ120608...L-...	1,5 - 3,0	30933864	30933866	30933867	
		1,5 - 5,0				
	CTNQ120612...L-...	1,5 - 3,0	30933868	30933869	30980913	
1,5 - 5,0						

Versione dei bordi di taglio		A32	A32	A32	A32	
CTNQ da ø 41 mm		a _p max. [mm]				
Lavorazione media	CTNQ090508...L-...	0,5 - 2,0	30933892	30933894	30933895	30950088
	CTNQ090508...R-...	0,5 - 2,0	30933896	30933897	30950112	30950092
	CTNQ090512...L-...	0,5 - 2,0	30933898	30933900	30933901	30950094
	CTNQ090512...R-...	0,5 - 2,0	30933902	30933903	30950118	30950099

M₁ Acciaio inossidabile

M₂ Acciaio fuso resistente alle alte temperature (materiali per turbocompressori)

I campi ap indicati sono raccomandazioni e possono variare in funzione del materiale lavorato.

M ₂			K				
austenitico ← resistente all'usura		ferritico → tenace	GJL ← resistente all'usura		GJS → tenace	GJL ← resistente all'usura	GJS → tenace
Metallo duro			Metallo duro				
CVD		PVD	CVD		PVD		
HC740	HC750	HP945	HC725	HC740	HP930	HP945	
H02	H02	H02	H02	H02	H02	H02	
30933846	30980873	30933848					
			30933926	30933846	30933929	30933848	
30933850	30980900	30933851					
			30933931	30933850	30933934	30933851	
30933852	30980902	30933854					
			30933936	30933852	30933939	30933854	
30933856	30980905	30933857					
			30933941	30933856	30933944	30933857	
30933864	30980907	30933866					
			30933956	30933864	30933959	30933866	
30933868	30980911	30933869					
			30933961	30933868	30933964	30933869	
A32	A32	A32	A32	A32	A32	A32	
30933892	30950088	30933894	30934005	30933892	30934008	30933894	
30933896	30950092	30933897	30934010	30933896	30934013	30933897	
30933898	30950094	30933900	30934015	30933898	30934018	30933900	
30933902	30950099	30933903	30934020	30933902	30934023	30933903	

CTGQ

Inserti a fissaggio tangenziale, quattro taglienti, foro cieco, con arrotondamento del tagliente



Materiale	P				K			
	non legato ← resistente all'usura	legato → tenace	non legato ← resistente all'usura	legato → tenace	GJL ← resistente all'usura	GJS → tenace	GJL ← resistente all'usura	GJS → tenace
Substrato	Metallo duro				Metallo duro			
Rivestimento	CVD		PVD		CVD		PVD	
Tipo di materiale da taglio	HC740	HC745	HP945	HP950	HC725	HC740	HP930	HP945

Versione dei bordi di taglio	H02	H02	H02	H02	H02	H02	H02	H02
------------------------------	-----	-----	-----	-----	-----	-----	-----	-----

CTGQ ø 65 mm		a_p max. [mm]								
Sgrossatura	CTGQ090504... LOOB041-...	1,5 - 3,0	31173955	31173956	31173957	31173958				
		1,5 - 4,0					31173959	31173955	31173980	31173957
	CTGQ090508... LOOB041-...	1,5 - 3,0	31173981	31173982	31173983	31173984				
		1,5 - 4,0					31173985	31173981	31173986	31173983
	CTGQ090512... LOOB041-...	1,5 - 3,0	31173987	31184714	31173988	31184715				
		1,5 - 4,0					31173989	31173987	31173990	31173988
	CTGQ ø 78 mm									
	CTGQ120604... LOOB081-...	1,5 - 3,0	31184725	31184726	31184728	31184729				
		1,5 - 5,0					31184724	31184725	31184727	31184728
	CTGQ120608... LOOB081-...	1,5 - 3,0	31173995	31173996	31173997	31173998				
		1,5 - 5,0					31173999	31173995	31174000	31173997
	CTGQ120612... LOOB081-...	1,5 - 3,0	31184731	31184732	31184734	31184735				
	1,5 - 5,0					31184730	31184731	31184733	31184734	

Versione dei bordi di taglio	A32	A32	A32	A32	A32	A32	A32	A32
------------------------------	-----	-----	-----	-----	-----	-----	-----	-----

CTGQ ø 65 mm		a_p max. [mm]								
Lavorazione media	CTGQ090504... LOOB041-...	0,5 - 2,0	31174001	31184716	31174002	31184717	31174003	31174001	31174004	31174002
	CTGQ090508... LOOB041-...	0,5 - 2,0	31174005	31184718	31174006	31184719	31174007	31174005	31174008	31174006
	CTGQ090512... LOOB041-...	0,5 - 2,0	31174009	31184720	31174010	31184721	31174011	31174009	31174012	31174010

CTGQ

Inserti a fissaggio tangenziale, quattro taglienti, foro passante, con arrotondamento del tagliente



Materiale	P				K					
	← non legato resistente all'usura	legato → tenace	← non legato resistente all'usura	legato → tenace	← GJL resistente all'usura	GJS → tenace	← GJL resistente all'usura	GJS → tenace		
Substrato	Metallo duro				Metallo duro					
Rivestimento	CVD		PVD		CVD		PVD			
Tipo di materiale da taglio	HC740	HC745	HP945	HP950	HC725	HC740	HP930	HP945		
Versione dei bordi di taglio	H02	H02	H02	H02	H02	H02	H02	H02		
CTGQ da \varnothing 65 mm		a_p max. [mm]								
Sgrossatura	CTGQ090508... L10B041-...	1,5 - 3,0	31174013	31174014	31174015	31174016				
		1,5 - 4,0					31174017	31174013	31174018	
	CTGQ da \varnothing 78 mm									
	CTGQ120608... L10B081-...	1,5 - 3,0	31174019	31174020	31174021	31174022				
	1,5 - 5,0					31174023	31174019	31174024	31174021	
Versione dei bordi di taglio	A32	A32	A32	A32	A32	A32	A32	A32		
CTGQ da \varnothing 65 mm		a_p max. [mm]								
Lavorazione media	CTGQ090508... L10B041-...	0,5 - 2,0	31174029	31184722	31174031	31184723	31174030	31174029	31174032	
									31174031	

CTHQ

Inserti a fissaggio tangenziale, quattro taglienti, senza arrotondamento del tagliente

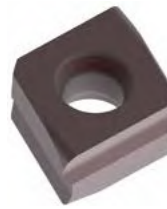

versione sinistra



versione destra

Materiale	P		M ₁	M ₂		M ₂
				non legato ← resistente all'usura		legato → tenace
Substrato	Metallo duro		Metallo duro	Metallo duro		Metallo duro
Rivestimento	CVD	PVD	CVD	CVD		PVD
Tipo di materiale da taglio	HC740	HP945	HC750	HC740	HC750	HP945

Versione dei bordi di taglio							
CTHQ da ø 28 mm		a_p max. [mm]					
Sgrossatura	CTHQ060408...L-...	1,5 - 2,5					
	CTHQ060408...R-...	1,5 - 2,5					
	Versione dei bordi di taglio			A32	H02	H02	H02
	CTHQ da ø 41 mm		a_p max. [mm]				
	CTHQ090508...L-...	1,5 - 3,0		30950084	30980629	30980631	30980632
		1,5 - 4,0					
	CTHQ090508...R-...	1,5 - 3,0		30950086	30980712	30980714	30980751
		1,5 - 4,0					
	CTHQ da ø 54 mm						
	CTHQ120608...L-...	1,5 - 3,0			30980759	30980765	30980766
		1,5 - 5,0					
	CTHQ120608...R-...	1,5 - 3,0			30980784	30980786	30980787
1,5 - 5,0							
Versione dei bordi di taglio			A32	A32	A32	A32	
CTHQ da ø 28 mm		a_p max. [mm]					
Lavorazione media	CTHQ060404...R-...	0,5 - 2,0					
	CTHQ da ø 41 mm						
	CTHQ090504...L-...	0,5 - 2,0	30933878	30933880	30933878	30980967	30933880
	CTHQ090504...R-...	0,5 - 2,0				30980968	
	CTHQ090508...L-...	0,5 - 2,0	30813598	30933885	30813598	30950084	30933885
	CTHQ090508...R-...	0,5 - 2,0				30950086	
	CTHQ da ø 54 mm						
	CTHQ120604...L-...	0,5 - 2,0	30933904		30933904		
CTHQ120604...R-...	0,5 - 2,0	30980051		30980051			

M₁ Acciaio inossidabile

M₂ Acciaio fuso resistente alle alte temperature (materiali per turbocompressori)

I campi a_p indicati sono raccomandazioni e possono variare in funzione del materiale lavorato.



Varianti rivestita,
a un tagliante:

A79, A80

K				N		
GJL ← resistente all'usura		GJS → tenace	GJL ← resistente all'usura	GJS → tenace		
Metallo duro				Metallo duro		PCD
CVD		PVD		-	PVD	-
HC725	HC740	HP930	HP945	HU616	HP615	PU617
H32	H32	H32	H32			
30933907	30980615	30933910	30980618			
30933912	30980621		30980625			
H02	H02	H02	H02			A80
30921024	30980629	30933917	30980632			30492720
30921023	30980712	30933923	30980751			30515656
30933946	30980759	30933949	30980766			
30933951	30980784	30933954	30980787			
A32	A32	A32	A32	A30	A30	A80
30679873	30942364		30942366	30477914	31010211	
30679874	30933878	30933979	30933880	30492760	31010211	30492764
30679875		30942374		30492770		30515411
30724676	30813598	30933994	30933885	31186236	30610917	
30789885		30942382		31264530	31203830	
30789886	30933904	30934028		30477929		
30789887	30980051	30980054		30477930		

CTHQ

Inserti a fissaggio tangenziale, quattro taglienti, foro cieco, con arrotondamento del tagliente

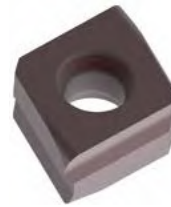

Materiale	P				M ₂	
	non legato resistente all'usura	legato tenace	non legato resistente all'usura	legato tenace		
Substrato	Metallo duro				Metallo duro	
Rivestimento	CVD		PVD		CVD	
Tipo di materiale da taglio	HC740	HC745	HP945	HP950	HC750	

Versione dei bordi di taglio		A53	A53	A53	A53	A32		
CTHQ da ø 65 mm		a _p max. [mm]						
Sgrossatura	CTHQ090508... L00B041-...	1,5 - 3,0	30933714	30933715	30933716	30933717	30933718	
		1,5 - 4,0						
	CTHQ090512... L00B041-...	1,5 - 3,0	30950047					
		1,5 - 4,0						
	CTHQ da ø 78 mm							
	CTHQ120608... L00B081-...	1,5 - 3,0	30933733	30933734				
	1,5 - 5,0							
CTHQ120612... L00B081-...	1,5 - 3,0	30950048						
	1,5 - 5,0							

Versione dei bordi di taglio		A32		A32				
CTHQ da ø 40 mm		a _p max. [mm]						
Lavorazione media	CTHQ060404... L00B021-...	0,5 - 2,0						
		0,5 - 2,0						
	CTHQ da ø 65 mm							
	CTHQ090504... L00B041-...	0,5 - 2,0	30950080		30988741			
	CTHQ090508... L00B041-...	0,5 - 2,0	30988732		30988742			
	CTHQ da ø 78 mm							
	CTHQ120604... L00B081-...	0,5 - 2,0						
	CTHQ120608... L00B081-...	0,5 - 2,0	30988734		30988744			

M₂ Acciaio fuso resistente alle alte temperature (materiali per turbocompressori)

I campi ap indicati sono raccomandazioni e possono variare in funzione del materiale lavorato.

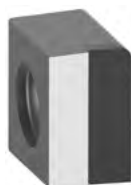

Variante rivestita,
a un tagliante:

A79, A80

K				N	
GJL ← resistente all'usura		GJS → tenace	GJL ← resistente all'usura	GJS → tenace	
Metallo duro				Metallo duro	PCD
CVD		PVD		-	-
HC725	HC740	HP930	HP945	HU616	PU617
H02	H02	H02	H02		A80
30933721	30988707	30933724	30988736		30492584
30933727	30988708	30933730	30988737		
30933735	30988709	30933738	30988738		
	30988730		30988739		
A32	A32	A32	A32	A30	A80
30679863	30988748	30933807	30988753	30477915	30492616
30679858	30950080	30933756	30988741	30328643	
30679859	30988732	30933765	30988742	30307194	30492584
30789881	31322355	31322356	31322357	30477928	
30789882	30988734	30933777	30988744	30477931	31213527

CTHQ

Inserti a fissaggio tangenziale, quattro taglienti, foro passante, con arrotondamento del tagliente



Materiale	P				M ₂		
	non legato resistente all'usura	legato tenace	non legato resistente all'usura	legato tenace			
Substrato	Metallo duro				Metallo duro		
Rivestimento	CVD		PVD		CVD		
Tipo di materiale da taglio	HC740	HC745	HP945	HP950	HC750		
Versione dei bordi di taglio	A53	A53	A53	A53	A32		
CTHQ da ø 65 mm a _p max. [mm]							
Sgrossatura	CTHQ090508... L10B041-...	1,5 - 3,0	30933783	30933784	30933785	30933786	30933787
	CTHQ da ø 78 mm						
	CTHQ120608... L10B081-...	1,5 - 3,0	30950082				
		1,5 - 5,0					
Versione dei bordi di taglio	A32		A32				
CTHQ da ø 40 mm a _p max. [mm]							
Lavorazione media	CTHQ060408... L10B021-...	0,5 - 2,0					
	CTHQ da ø 65 mm						
	CTHQ090508... L10B041-...	0,5 - 2,0	30988749		30988755		
	CTHQ da ø 78 mm						
	CTHQ120608... L10B081-...	0,5 - 2,0	30988750		30988756		

M₂ Acciaio fuso resistente alle alte temperature (materiali per turbocompressori)

I campi ap indicati sono raccomandazioni e possono variare in funzione del materiale lavorato.



Varianti rivestita,
a un tagliente:

A79, A80

K				N	
GJL ← resistente all'usura		GJS → tenace		GJL ← resistente all'usura	
GJS → tenace		GJS → tenace			
Metallo duro				Metallo duro	
CVD		PVD		PCD	
-		-		-	
HC725	HC740	HP930	HP945	HU616	PU617
H02	H02	H02	H02		A80
30933790	30988746	30933793	30988751		30492657
30933796	30988747	30933799	30988752		
A32	A32	A32	A32	A30	A80
30679863	30988748	30933807	30988753	30477916	
30679865	30988749	30933825	30988755	30307197	30492657
	30988750		30988756	30477932	

FTNQ

Inserti a fissaggio tangenziale, quattro taglienti, senza arrotondamento del tagliente



Materiale	P		M ₁	M ₂	
				austenitico resistente all'usura	ferritico tenace
Substrato	Metallo duro		Metallo duro	Metallo duro	
Rivestimento	CVD	PVD	CVD	CVD	
Tipo di materiale da taglio	HC740	HP945	HC750	HC740	HC750

Versione dei bordi di taglio	H02	H02	A32	H02	H02
------------------------------	-----	-----	-----	-----	-----

FTNQ da ø 30 mm a_p max. [mm]

Sgrossatura	FTNQ090508...L-...	1,5 - 3,0	30934169	30934170	30934171	30934169	30980508	
		1,5 - 4,0						
	FTNQ da ø 40 mm							
	FTNQ120608...L-...	1,5 - 3,0	30934188	30934189		30934188	30980523	
		1,5 - 5,0						
	FTNQ120608...R-...	1,5 - 3,0	30934196	30934197		30934196		
		1,5 - 5,0						

Versione dei bordi di taglio	A32	A32		A32	A32
------------------------------	-----	-----	--	-----	-----

FTNQ da ø 30 mm a_p max. [mm]

Lavorazione media	FTNQ090508...L-...	0,5 - 2,0	30934222	30934223		30934222	30934171
		0,5 - 2,0					

M₁ Acciaio inossidabile

M₂ Acciaio fuso resistente alle alte temperature (materiali per turbocompressori)

I campi ap indicati sono raccomandazioni e possono variare in funzione del materiale lavorato.

	M ₂	K				
		GJL ← resistente all'usura		GJS → GJL tenace resistente all'usura		GJS → tenace
	Metallo duro	Metallo duro				
	PVD	CVD		PVD		
HP945	HC725	HC740	HP930	HP945		
	H02	H02	H02	H02	H02	
	30934170					
		30934173	30934169	30934175	30934170	
	30934189					
		30934192	30934188	30934194	30934189	
	30934197					
		30934198	30934196	30934200	30934197	
	A32	A32	A32	A32	A32	
	30934223					
		30934173	30934222	30934175	30934223	

FTGQ

Inserti a fissaggio tangenziale, quattro taglienti, foro cieco, con arrotondamento del tagliente



Materiale	P				K			
	non legato ← resistente all'usura	legato → tenace	non legato ← resistente all'usura	legato → tenace	GJL ← resistente all'usura	GJS → tenace	GJL ← resistente all'usura	GJS → tenace
Substrato	Metallo duro				Metallo duro			
Rivestimento	CVD		PVD		CVD		PVD	
Tipo di materiale da taglio	HC740	HC745	HP945	HP950	HC725	HC740	HP930	HP945

Versione dei bordi di taglio		H02	H02	H02	H02	H02	H02	H02	H02	
FTGQ da ø 30 mm		a_p max. [mm]								
Sgrossatura	FTGQ090504...L00B016- ...	1,5 - 3,0	31174033	31174034	31174035	31174036				
		1,5 - 4,0					31174037	31174033	31174038	31174035
	FTGQ090508...L00B016- ...	1,5 - 3,0	31174039	31174040	31174041	31174042				
		1,5 - 4,0					31174043	31174039	31174044	31174041
	FTGQ090512...L00B016- ...	1,5 - 3,0	31184737	31184738	31184740	31184741				
		1,5 - 4,0					31184736	31184737	31184739	31184740
	FTGQ da ø 40 mm									
	FTGQ120604...L00B021- ...	1,5 - 3,0	31184755	31184756	31184758	31184759				
		1,5 - 5,0					31184754	31184755	31184757	31184758
	FTGQ120608...L00B021- ...	1,5 - 3,0	31174045	31174046	31174047	31174048				
		1,5 - 5,0					31174049	31174045	31174050	31174047
	FTGQ120612...L00B021- ...	1,5 - 3,0	31184761	31184762	31184764	31184765				
	1,5 - 5,0					31184760	31184761	31184763	31184764	

Versione dei bordi di taglio		A32	A32	A32	A32	A32	A32	A32	A32	
FTGQ da ø 30 mm		a_p max. [mm]								
Lavorazione media	FTGQ090504...L00B016- ...	0,5 - 2,0	31174051	31184742	31174053	31184743	31174052	31174051	31174054	31174053
	FTGQ090508...L00B016- ...	0,5 - 2,0	31174055	31184744	31174057	31184745	31174056	31174055	31174058	31174057
	FTGQ090512...L00B016- ...	0,5 - 2,0	31184747	31184748	31184750	31184751	31184746	31184747	31184749	31184750

FTGQ

Inserti a fissaggio tangenziale, quattro taglienti, foro passante, con arrotondamento del tagliente



Materiale	P				K					
	← non legato resistente all'usura	legato tenace →	← non legato resistente all'usura	legato tenace →	← GJL resistente all'usura	GJS tenace →	← GJL resistente all'usura	GJS tenace →		
Substrato	Metallo duro				Metallo duro					
Rivestimento	CVD		PVD		CVD		PVD			
Tipo di materiale da taglio	HC740	HC745	HP945	HP950	HC725	HC740	HP930	HP945		
Versione dei bordi di taglio	H02	H02	H02	H02	H02	H02	H02	H02		
FTGQ da ø 30 mm a _p max. [mm]										
Sgrossatura	FTGQ090508...L10B016-	1,5 - 3,0	31174059	31174060	31174061	31174062				
	...	1,5 - 4,0					31174063	31174059	31174065	
	FTGQ da ø 40 mm									
	FTGQ120608...L10B021-	1,5 - 3,0	31174066	31174067	31174068	31174069				
...	1,5 - 5,0					31174070	31174066	31174071	31174068	
Versione dei bordi di taglio	A32	A32	A32	A32	A32	A32	A32	A32		
FTGQ da ø 30 mm a _p max. [mm]										
Lavorazione media	FTGQ090508...L10B016-	0,5 - 2,0	31174076	31184752	31174078	31184753	31174077	31174076	31174079	31174078
	...									

FTHQ

Inserti a fissaggio tangenziale, quattro taglienti, senza arrotondamento del tagliente



Materiale	P		M ₁			austenitico resistente all'usura	ferritico tenace
	Metallo duro		Metallo duro				
Substrato	Metallo duro		Metallo duro				
Rivestimento	CVD	PVD	CVD	PVD			
Tipo di materiale da taglio	HC740	HP945	HC750	HC740	HC750		

Versione dei bordi di taglio		A53	A53	A32	H02	H02	
FTHQ da ø 30 mm		a_p max. [mm]					
Sgrossatura	FTHQ090508...L-...	1,5 - 3,0	30980167	30934159	30934160	30912756	30980484
		1,5 - 4,0					
	FTHQ090508...R-...	1,5 - 3,0	30934166	30934167	30950130	30980488	
		1,5 - 4,0					
	FTHQ da ø 40 mm						
	FTHQ120608...L-...	1,5 - 3,0	30934177	30934178	30934179	30980491	30980493
	1,5 - 5,0						
FTHQ120608...R-...	1,5 - 3,0	30934185	30934186	30950135	30980501		
	1,5 - 5,0						

Versione dei bordi di taglio		A32	A32	A32	A32	
FTHQ da ø 22 mm		a_p max. [mm]				
Lavorazione media	FTHQ060404...L-...	0,5 - 1,5				
	FTHQ060404...R-...	0,5 - 1,5				
	FTHQ060408...L-...	0,5 - 1,5				
	FTHQ060408...R-...	0,5 - 1,5				
	FTHQ da ø 30 mm					
	FTHQ090504...L-...	0,5 - 2,0				
	FTHQ090504...R-...	0,5 - 2,0				
	FTHQ090508...L-...	0,5 - 2,0	30934214	30934215	30934214	30934160
	FTHQ090508...R-...	0,5 - 2,0				30950130
	FTHQ da ø 40 mm					
	FTHQ120604...L-...	0,5 - 2,0				
	FTHQ120604...R-...	0,5 - 2,0				
	FTHQ120608...L-...	0,5 - 2,0	30934231	30934232	30934231	30934179
	FTHQ120608...R-...	0,5 - 2,0				30950135

M₁ Acciaio inossidabile

M₂ Acciaio fuso resistente alle alte temperature (materiali per turbocompressori)

I campi a_p indicati sono raccomandazioni e possono variare in funzione del materiale lavorato.

FTHQ

Inserti a fissaggio tangenziale, quattro taglienti, foro cieco, con arrotondamento del tagliente



Materiale	P		M	
	non legato ← resistente all'usura	legato → tenace	non legato ← resistente all'usura	legato → tenace
Substrato	Metallo duro		Metallo duro	
Rivestimento	CVD		PVD	
Tipo di materiale da taglio	HC740		HP945	

Versione dei bordi di taglio		A53	A53	A32	
FTHQ da ø 30 mm a_p max. [mm]					
Sgrossatura	FTHQ090508... L00B016-...	1,5 - 3,0	30980181	30934058	
		1,5 - 4,0			
	FTHQ090512...L00B016- ...	1,5 - 3,0	30934075	30934076	
		1,5 - 4,0			
	FTHQ da ø 40 mm				
	FTHQ120608... L00B021-...	1,5 - 3,0	30934081	30934082	
	1,5 - 5,0				
FTHQ120612...L00B021- ...	1,5 - 3,0	30934087	30934088		
	1,5 - 5,0				

Versione dei bordi di taglio		A32			
FTHQ da ø 22 mm a_p max. [mm]					
Lavorazione media	FTHQ060404...L00B012-...	0,5 - 1,5			
	FTHQ060408...L00B012-...	0,5 - 1,5			
	FTHQ da ø 30 mm				
	FTHQ090504...L00B016-...	0,5 - 2,0	30950123		
	FTHQ090508...L00B016-...	0,5 - 2,0	30901249		
	FTHQ da ø 40 mm				
	FTHQ120604...L00B021-...	0,5 - 2,0			
	FTHQ120608...L00B021-...	0,5 - 2,0	30934113		
FTHQ120612...L00B021-...	0,5 - 2,0				



Variante rivestita,
a un tagliante:

A79, A80

K		K		N		
GJL ← resistente all'usura		GJS → tenace	GJL ← resistente all'usura		GJS → tenace	
Metallo duro CVD		Metallo duro PVD		Metallo duro		PCD
HC725	HC740	HP930	HP945	–	–	–
				HU616		PU617
	H02	H02	H02	H02		A80
30934071	30934057	30934073	30988760			30492784
30934077	30988757	30934079	30988761			
30934083	30988758	30934085	30988762			
30934089	30988759	30934091	30988763			
	A32	A32	A32	A32	A30	A79
						A80
30679879	30950121	30934095	30988764	30477935		
30679880	30950122	30934099	30988765	30477936	30492816	
30679881	30950123	30934103	30988766	30477942		
30679882	30901249	30934111	30934106	30478043		30492784
				30477950		
30934115	30934113	30934118	30934114	30477952		
				30492842		

FTHQ

Inserti a fissaggio tangenziale, quattro taglienti, foro passante, con arrotondamento del tagliente



Materiale	P		M	K			
	Metallo duro		Metallo duro	Metallo duro			
Substrato	Metallo duro		Metallo duro	Metallo duro			
Rivestimento	CVD	PVD	CVD	CVD			
Tipo di materiale da taglio	HC740	HP945	HC750	HC725	HC740		
Versione dei bordi di taglio	A53	A53	A32	H02	H02		
FTHQ da ø 30 mm a_p max. [mm]							
Sgrossatura	FTHQ090508...L10B016- ...	1,5 - 3,0	30934120	30934121	30934122	30934124	30988767
	FTHQ da ø 40 mm						
	FTHQ120608...L10B021- ...	1,5 - 3,0	30934128	30934129			
		1,5 - 5,0				30934130	30988768
Versione dei bordi di taglio	A32	A32		A32	A32		
FTHQ da ø 22 mm a_p max. [mm]							
Lavorazione media	FTHQ060408... L10B012-...	0,5 - 1,5				30679886	30942386
	FTHQ da ø 30 mm						
	FTHQ090508... L10B016-...	0,5 - 2,0	30942389	30942390		30679888	30942389
	FTHQ da ø 40 mm						
FTHQ120608... L10B021-...	0,5 - 2,0	30942391	30942392		30789889	30942391	



Variante rivestita,
a un tagliante:

A79, A80

K		N		
GJL ← resistente all'usura		GJS → tenace		
Metallo duro		Metallo duro		PCD
PVD		-		-
HP930	HP945	HU616		PU617
H02	H02			A80
30934126	30988769			30492850
30934132	30988770			30668155
A32	A32	A30	A79	A80
30942394	30942388	30477937	30492868	
30942397	30942390	30477944		30492850
30942400	30942392	30477953		30668155

STHD - STHE

Inserti a fissaggio tangenziale, quattro taglienti, smussi, versione neutra



Variante rivestita,
a un tagliente:

D80

Materiale	M ₂	K		N	
Substrato	Metallo duro	Metallo duro		Metallo duro	PCD
Rivestimento	PVD	CVD	PVD	-	-
Tipo di materiale da taglio	HP930	HC725	HP930	HU616	PU617

Versione dei bordi di taglio		D02	D02	D02	D00	D80	
STH_06		a _p max. [mm]					
Smussi	STHD060300...N-...	0,1 - 4,2	30950141	30774242	30950141	30213884	30493003
	STHE060300...N-...	0,1 - 4,2	30950142	30789899	30950142	30228119	30370122
	STH_09						
	STHD09T300...N-...	0,1 - 6,3	30950143	30631370	30950143	30215016	30493005
	STHE09T300...N-...	0,1 - 6,3	30950144	30631351	30950144	30257365	30493006

M₂ Acciaio fuso resistente alle alte temperature (materiali per turbocompressori)

I campi ap indicati sono raccomandazioni e possono variare in funzione del materiale lavorato.

Appunti







Accessori per inserti a fissaggio tangenziale

Inserito a fissaggio meccanico	Dimensione inserto	Vite di serraggio					Cacciavite
		Dimensioni [MxI]	Denominazione	Coppia di serraggio [Nm]	Dimensioni Torx	Codice	Codice
CT... 	0604	M2.5 x 8.7	MN659 M2.5x8.7-TX8-IP	1	TX8-IP	30533284	30414760
	0905	M3.5 x 11	MN659 M3.5x11-TX10-IP	2,8	TX10-IP	10105079	30414763
	1206	M5 x 14	MN659 M5x14-TX20-IP	7,5	TX20-IP	10006485	30414766
FT... 	0604	M2.5 x 8.7	MN659 M2.5x8.7-TX8-IP	1	TX8-IP	30533284	30414760
	0905	M3.5 x 11	MN659 M3.5x11-TX10-IP	2,8	TX10-IP	10105079	30414763
	1206	M5x14	MN659 M5x14-TX20-IP	7,5	TX20-IP	10006485	30414766
ST... 	0603	M2.5 x 6	MN659 M2.5x6-TX8-IP	1	TX8-IP	10105073	30414760
	09T3	M3.5x9	MN659 M3.5x9-TX15-IP	2,8	TX15-IP	10105078	30414764

Pasta per viti resistente alle alte temperature

Pasta ceramica / tubo PE sigillabile da 30 g	30861389
--	----------

Accessori per inserti a fissaggio radiale

Inserto a fissaggio meccanico	Dimensione inserto	Vite di serraggio					Cacciavite
		Dimensioni [MxI]	Denominazione	Coppia di serraggio [Nm]	Dimensioni Torx	Codice	Codice
CC... 	0602	M2.5 x 6	MN659 M2.5x6-TX8-IP	1	TX8-IP	10105073	30414760
	09T3	M3.5 x 9	MN659 M3.5x9-TX15-IP	2,8	TX15-IP	10105078	30414764
	1204	M5 x 11	MN659 M5x11-TX20-IP	7,5	TX20-IP	10105082	30414766
DC... 	0702	M2.5 x 6	MN659 M2.5x6-TX8-IP	1	TX8-IP	10105073	30414760
	11T3	M3.5 x 9	MN659 M3.5x9-TX15-IP	2,8	TX15-IP	10105078	30414764
	1504	M5x11	MN659 M5x11-TX20-IP	7,5	TX20-IP	10105082	30414766
SP.. 	0603	M2.5 x 6	MN659 M2.5x6-TX8-IP	1	TX8-IP	10105073	30414760
TC... 	06T1	M2 x 4.95	MN659 M2x4.95-TX6-IP	0,5	TX6-IP	10002712	30414758
	0902	M2.2 x 5.5	MN659 M2.2x5.5-TX7-IP	0,8	TX7-IP	10105070	30414759
	1102	M2.5 x 6	MN659 MN2.5x6-TX8-IP	1	TX8-IP	10105073	30414760
	16T3	M3.5 x 9	MN659 M3.5x9-TX15-IP	2,8	TX15-IP	10105078	30414764
	2204	M5x11	MN659 M5x11-TX20-IP	7,5	TX20-IP	10105082	30414766
SC... 	09T3	M3.5 x 9	MN659 M3.5x9-TX15-IP	2,8	TX15-IP	10105078	30414764
	1204	M5 x 11	MN659 M5x11-TX20-IP	7,5	TX20-IP	10105082	30414766
VB-/VC... 	1103	M2.5 x 6	MN659 MN2.5x6-TX8-IP	1	TX8-IP	10105073	30414760
	1604	M3.5 x 9	MN659 M3.5x9-TX15-IP	2,8	TX15-IP	10105078	30414764

Parametri di lavorazione consigliati per utensili di barenatura con inserti a fissaggio meccanico (1/2)

Velocità di taglio [m/min]

GTM*	Materiale		Resistenza/durezza [N/mm ²] [HRC]	Cermet		PcBN	
				CVD rivestito	PVD rivestito	non rivestito	
				CC112	CP872	FU430	HC725
P	P1	P1.1	Acciai da costruzione, automatici, da cementazione e da bonifica, non legati	< 700	160-600	200-300	
		P1.2	Acciai da costruzione, automatici, da cementazione e da bonifica, non legati	< 1.200	160-500		
	P2	P2.1	Acciai da nitrurazione, da cementazione e da bonifica, legati	< 900	160-600	120-220	
		P2.2	Acciai da nitrurazione, da cementazione e da bonifica, legati	< 1.400	140-400		
	P3	P3.1	Acciai per utensili, per cuscinetti volventi, armonici e per lavorazioni veloci**	< 800	160-600	120-220	
		P3.2	Acciai per utensili, per cuscinetti volventi, armonici e per lavorazioni veloci**	< 1.000	140-400		
		P3.3	Acciai per utensili, per cuscinetti volventi, armonici e per lavorazioni veloci**	< 1.500			
	P4	P4.1	Acciai per utensili, per cuscinetti volventi, armonici e per lavorazioni veloci**		140-400		
	P5	P5.1	Acciai inossidabili, ferritici e martensitici		140-400		
	P6	P6.1	Acciaio fuso		140-400		
M	M1	M1.1	Acciaio fuso, ferritico e martensitico	< 700	100-500		
		M1.2	Acciai inossidabili, ferritici/austenitici (Duplex)	< 1.000	100-450		
	M2	M2.1	Acciaio fuso inossidabile, austenitico	< 700	100-500		
	M3	M3.1	Acciaio fuso inossidabile, ferritico/austenitico (Duplex)	< 1.000	100-450		
K	K1	K1.1	Ghisa con grafite lamellare (ghisa grigia), GJL	< 300		400-1.000	140-300
		K2.1	Ghisa con grafite sferoidale, GJS	< 500		350-800	120-260
	K2	K2.2	Ghisa con grafite sferoidale, GJS	≤ 800			120-220
		K2.3	Ghisa con grafite sferoidale, GJS	> 800			80-140
	K3	K3.1	Ghisa con grafite vermicolare, GJV; acciaio fuso malleabile, GJM	< 500			80-130
		K3.2	Ghisa con grafite vermicolare, GJV; acciaio fuso malleabile, GJM	> 500			80-120
N	N1	N1.1	Alluminio, non legato e legato < 3% Si				
		N1.2	Alluminio, legato ≤ 7% Si				
		N1.3	Alluminio, legato > 7-12% Si				
		N1.4	Alluminio, legato > 12% Si				
	N2	N2.1	Rame, non legato e bassolegato	< 300			
		N2.2	Rame, legato	> 300			
	N3	N2.3	Ottone, bronzo, ghisa rossa	< 1.200			
		N3.1	Grafite, > 8 µm	< 1.200			
	N4	N3.2	Grafite, ≤ 8 µm				
		N4.1	Plastica, thermoplast				
N4.2		Plastica, duroplast					
	N4.3	Plastica, materiali espansi					
K+K	K1.1, K1.2	Lavorazione mista di ghisa (GJL e GJS)					
K+P	K1.1, Sinter	Lavorazione mista di ghisa e acciaio sinterizzato					
N+K	N1.2, K1.1	Lavorazione mista di alluminio e ghisa (GJL)					
	N1.2, K1.2	Lavorazione mista di alluminio e ghisa (GJS)					
N+P	N1.2, Sinter	Lavorazione mista di alluminio e acciaio sinterizzato					

* Gruppi di materiale MAPAL

** Qualora la somma dei componenti di lega Cr, Mo, Ni, V, W equivalesse a > 8%, selezionare il gruppo di materiale MAPAL immediatamente superiore.

Metallo duro												
Rivestito in CVD												
	HC740	HC745	HC750	HC815	HC820	HC825	HC830	HC850	HC855	HC865	HC875	HC885
	100-220	100-200						180-300	170-280	120-220		
	100-220	100-200						170-280	160-250	120-200		
	100-180	100-180						150-270	150-250	100-180		
	80-150	80-150						150-260	150-240	80-170		
	100-180	100-180						150-260	140-240	80-160		
	90-130	80-130						140-240	140-230	80-140		
	90-130	80-130						140-240	130-230	80-140		
	90-130	80-130						140-240	120-220	80-140		
	90-130	80-130										
			100-160								200-300	180-280
			80-140								200-280	160-260
	70-120	70-120	70-120								180-260	140-240
			70-130								160-240	120-220
	120-240			200-380	200-380	180-300	180-300					
	110-230			150-280	150-280	130-260	130-260					
	100-200			150-220	150-220	130-200	130-200					
	80-120			150-200	150-200	130-200	130-200					
	80-120			150-200	150-200	130-200	130-200					
	80-120			150-200	150-200	130-200	130-200					

I valori di lavoro indicati sono valori orientativi.

I dati ottimali per la specifica applicazione devono essere rilevati eseguendo diversi tentativi o durante l'effettiva lavorazione.

Parametri di lavorazione consigliati per utensili di barenatura con inserti a fissaggio meccanico (2/2)

Velocità di taglio [m/min]

GTM*	Materiale		Resistenza/durezza [N/mm ²] [HRC]	Con rivestimento in PVD				
				HP615	HP880	HP885	HP895	
P	P1	P1.1	Acciai da costruzione, automatici, da cementazione e da bonifica, non legati	< 700		100-220		100-220
		P1.2	Acciai da costruzione, automatici, da cementazione e da bonifica, non legati	< 1.200		100-220		100-220
	P2	P2.1	Acciai da nitrurazione, da cementazione e da bonifica, legati	< 900		100-220		100-220
		P2.2	Acciai da nitrurazione, da cementazione e da bonifica, legati	< 1.400		100-200		100-200
	P3	P3.1	Acciai per utensili, per cuscinetti volventi, armonici e per lavorazioni veloci**	< 800		80-200		80-200
		P3.2	Acciai per utensili, per cuscinetti volventi, armonici e per lavorazioni veloci**	< 1.000		80-200		80-200
		P3.3	Acciai per utensili, per cuscinetti volventi, armonici e per lavorazioni veloci**	< 1500				
	P4	P4.1	Acciai per utensili, per cuscinetti volventi, armonici e per lavorazioni veloci**			80-200		80-200
	P5	P5.1	Acciai inossidabili, ferritici e martensitici			80-200		80-200
	P6	P6.1	Acciaio fuso					
M	M1	M1.1	Acciaio fuso, ferritico e martensitico	< 700		150-220	100-180	150-220
		M1.2	Acciai inossidabili, ferritici/austenitici (Duplex)	< 1.000		120-200	100-160	120-200
	M2	M2.1	Acciaio fuso inossidabile, austenitico	< 700		100-180	80-150	100-180
	M3	M3.1	Acciaio fuso inossidabile, ferritico/austenitico (Duplex)	< 1.000		100-180	60-140	100-180
K	K1	K1.1	Ghisa con grafite lamellare (ghisa grigia), GJL	< 300				
		K2.1	Ghisa con grafite sferoidale, GJS	< 500				
	K2	K2.2	Ghisa con grafite sferoidale, GJS	≤ 800				
		K2.3	Ghisa con grafite sferoidale, GJS	> 800				
	K3	K3.1	Ghisa con grafite vermicolare, GJV; acciaio fuso malleabile, GJM	< 500				
		K3.2	Ghisa con grafite vermicolare, GJV; acciaio fuso malleabile, GJM	> 500				
N	N1	N1.1	Alluminio, non legato e legato < 3% Si		150-600			
		N1.2	Alluminio, legato ≤ 7% Si		100-500			
		N1.3	Alluminio, legato > 7-12% Si		100-400			
		N1.4	Alluminio, legato > 12% Si					
	N2	N2.1	Rame, non legato e bassolegato	< 300		100-350		
		N2.2	Rame, legato	> 300		100-300		
		N2.3	Ottone, bronzo, ghisa rossa	< 1.200		100-250		
	N3	N3.1	Grafite, > 8 µm	< 1.200				
		N3.2	Grafite, ≤ 8 µm					
	N4	N4.1	Plastica, thermoplast					
N4.2		Plastica, duroplast						
N4.3		Plastica, materiali espansi						
K1+K2	K1.1, K1.2	Lavorazione mista di ghisa (GJL e GJS)						
K+P	K1.1, Sinter	Lavorazione mista di ghisa e acciaio sinterizzato						
N+K	N1.2, K1.1	N1.2, K1.1	Lavorazione mista di alluminio e ghisa (GJL)					
		N1.2, K1.2	Lavorazione mista di alluminio e ghisa (GJS)					
N+P	N1.2, Sinter	Lavorazione mista di alluminio e acciaio sinterizzato						

* Gruppi di materiale MAPAL

** Qualora la somma dei componenti di lega Cr, Mo, Ni, V, W equivalesse a > 8%, selezionare il gruppo di materiale MAPAL immediatamente superiore.

Metallo duro							PCD			
			Con rivestimento in PVD, lavorazione mista				non rivestito	non rivestito		
HP930	HP945	HP950	HP525-P	HP530-P	HP540-P	HP545-P	HU616	PU617	PU660	PU670
	100-180	100-160								
	100-180	100-160								
	100-180	100-160								
	80-150	80-150								
	100-180	100-160								
	80-130	90-130								
	80-130	90-130								
	80-130	90-130								
	80-130	90-130								
	70-120	70-120								
140-220	120-200									
120-200	120-180									
120-180	120-180									
80-140	80-120									
60-130	60-100									
60-120	60-100									
							150-500	450-2200	450-2200	410-1980
							100-450	400-1700	400-1700	360-1530
							100-400	350-1300	350-1300	320-1170
								200-800	200-800	180-720
							100-250	250-600	250-600	230-540
							100-220	200-600	200-600	180-540
							80-220	200-500	200-500	180-450
							120-480	300-600	300-600	270-540
							250-500	400-1000	400-1000	360-900
							250-500	400-1000	400-1000	360-900
			120-220	120-220	120-200					
				120-200	120-200	110-200				
			120-300	120-300	120-230					
			120-280	120-280	120-230					
				120-220	120-230	110-200				

I valori di lavoro indicati sono valori orientativi.

I dati ottimali per la specifica applicazione devono essere rilevati eseguendo diversi tentativi o durante l'effettiva lavorazione.

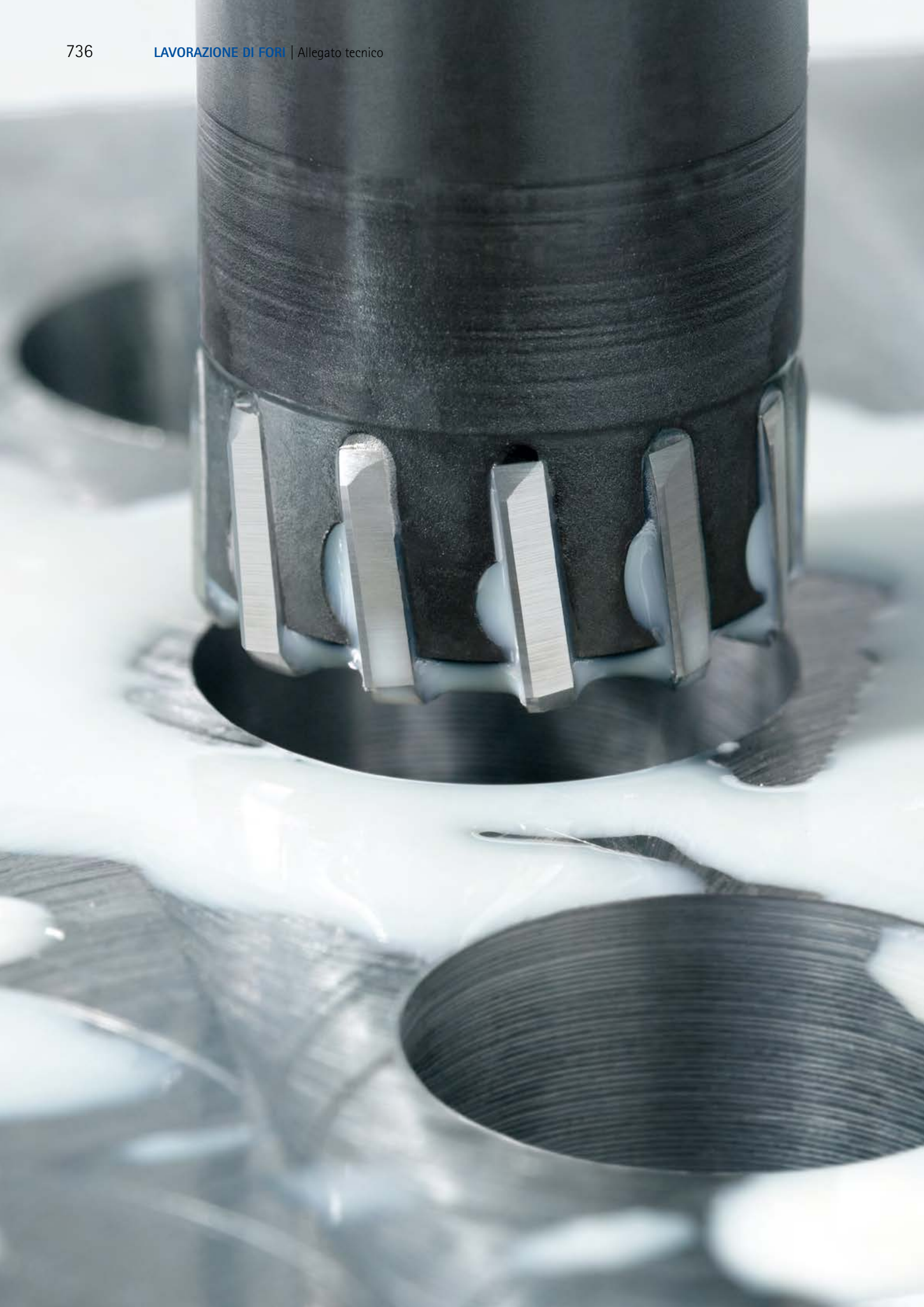

ALLEGATO TECNICO

Indicazioni per l'applicazione e l'utilizzo, dati di taglio



ALLEGATO TECNICO

Foratura

Indicazioni per l'applicazione	
Punta ad inserto intercambiabile TTD-Tritan	740
Foratura profonda	742
Punta con inserto a fissaggio meccanico	744
Indicazioni per l'utilizzo	
Punta con inserto QTD	746
Punta ad inserto intercambiabile TTD	748
Punta ad inserto intercambiabile TTD-Tritan	750

Alesatura e barenatura di precisione

Geometrie di imbocco e angoli di spoglia	752
Indicazioni per l'utilizzo	
Sistema HFS	754
HPR400 e HPR400 plus	756
Alesatori a un tagliente	758
Sistema EasyAdjust	760
Risoluzione dei problemi	764

Barenatura e tornitura

Terminologia e formule	766
Valori orientativi del diametro minimo di barenatura	770
Risoluzione dei problemi	
Forme di usura su inserti a fissaggio meccanico	772
Guida pratica	773

Indicazioni per l'applicazione delle punte ad inserto intercambiabile TTD-Tritan

La punta ad inserto intercambiabile a tre taglienti TTD-Tritan garantisce una trasmissione della coppia ottimale presso l'innesto, assicurando nel contempo un'elevata precisione di cambio e di concentricità. La testina intercambiabile può essere sostituita rapidamente e in completa sicurezza; il sistema esclude un eventuale posizionamento errato. L'utensile viene fornito completo della chiave TORX® adatta e della relativa impugnatura, che consentono di serrare con la massima precisione la testina intercambiabile al rispettivo supporto mediante la speciale vite di serraggio.

Situazione refrigerante:

La pressione del refrigerante dipende dalla profondità di foratura: 3xD: 8 bar | 5xD: 12 bar



Massimo angolo di entrata e di uscita:

In fase di inizio foratura e di fuoriuscita dal foro su superfici oblique, ridurre v_f del 50%.

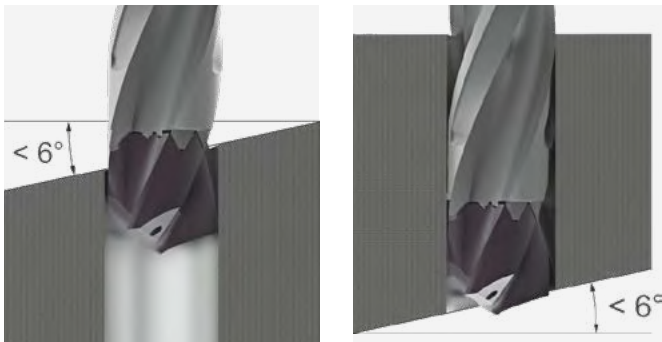

Foro passante:

All'uscita del foro si consiglia di non ridurre i parametri di lavorazione.

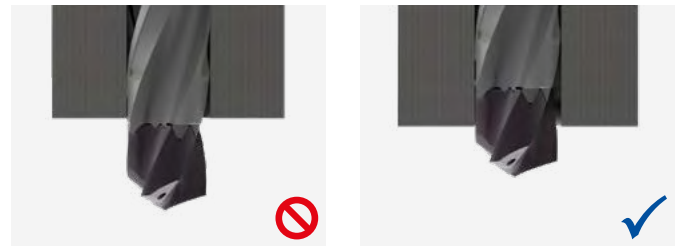

Precisione di concentricità:

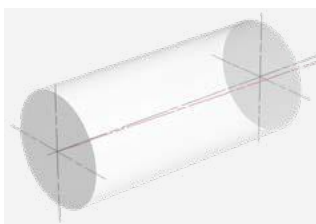

Max. 0,02 mm



Max. 0,04 mm

Niente corsa rapida in fase di estrazione:

Per la velocità di estrazione si consiglia il quintuplo del valore della velocità di avanzamento.

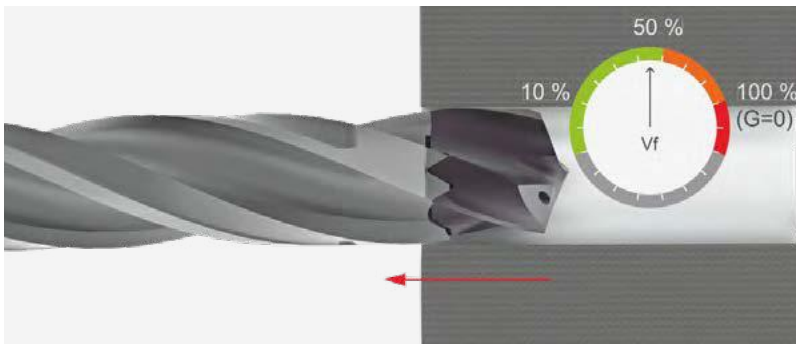
**Condizioni di lavorazione:**

Foro fuori centro;
Tagliante trasversale ingranato



Foro fuori centro;
Tagliante trasversale non ingranato



Sfondamento con controforo;
 $v_f = -50\%$



Foro centrale $e \ll D$



Foro centrale $e \approx D$



Foro centrale $e \gg D$

Foratura profonda

Per MEGA-Deep-Drill | MEGA-Deep-Drill-Alu

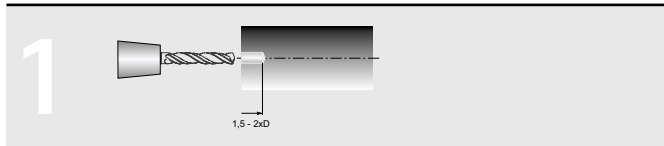

Impostazione di un foro pilota

- Per una raccomandazione per punta pilota, vedere pagina seguente (oppure più grande di 0,01-0,02 mm rispetto al diametro della punta di foratura profonda)
- Profondità del foro pilota tra 1,5 e 2xD

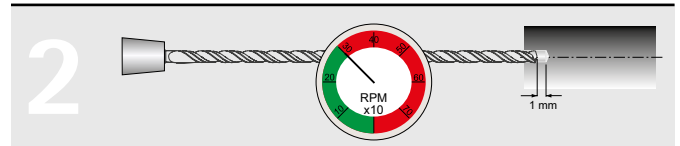

MEGA-Deep-Drill - Inserimento nel foro pilota

- Inserire con max. 300 min⁻¹ e v_f = 1000 mm/min
- Senza refrigerante, fino a 1 mm dal fondo del foro pilota
- Attivare il refrigerante

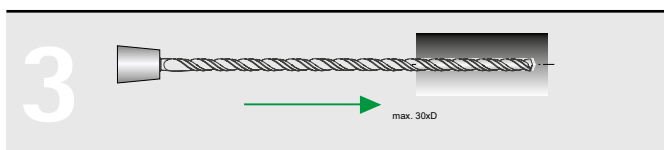

Foratura con MEGA-Deep-Drill

- Velocità di taglio (v_c) e avanzamento (f) secondo quanto indicato nella tabella (vedere pagina 286). Foratura senza cicli di allentamento

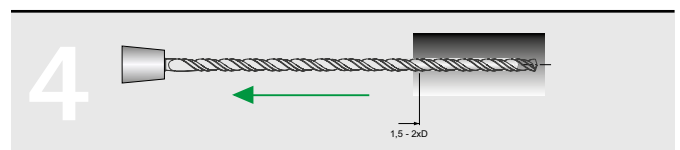

MEGA-Deep-Drill - Ritrazione

- Ritrazione con numero di giri attuale e avanzamento doppio (= 2 x v_f) fino a 1,5 - 2xD al termine del foro

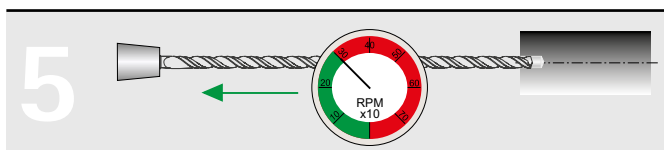

MEGA-Deep-Drill - Estrazione dal foro

- Disattivare il refrigerante
- Estrarre con max. 300 min⁻¹ e v_f = 1000 mm/min

Indicazioni per l'applicazione con diametri ≤ 3 mm:

- Selezionare un tipo di refrigerante adatto a utensili di dimensioni molto ridotte per un lubrorefrigerante ottimale
- Filtrazione efficace del fluido refrigerante per evitare l'intasamento dei canali di raffreddamento
- Scegliere il ciclo di foratura adatto (se necessario, foratura con cicli di allentamento)

Pressione del refrigerante necessaria

Per MEGA-Deep-Drill | MEGA-Deep-Drill-Alu

	ø 3 - 5 mm	ø 5 - 8 mm	ø 8 - 12 mm	ø 12 - 16 mm
AI	60 bar	40 bar	30 bar	25 bar
MQL	12 bar	10 bar	9 bar	8 bar

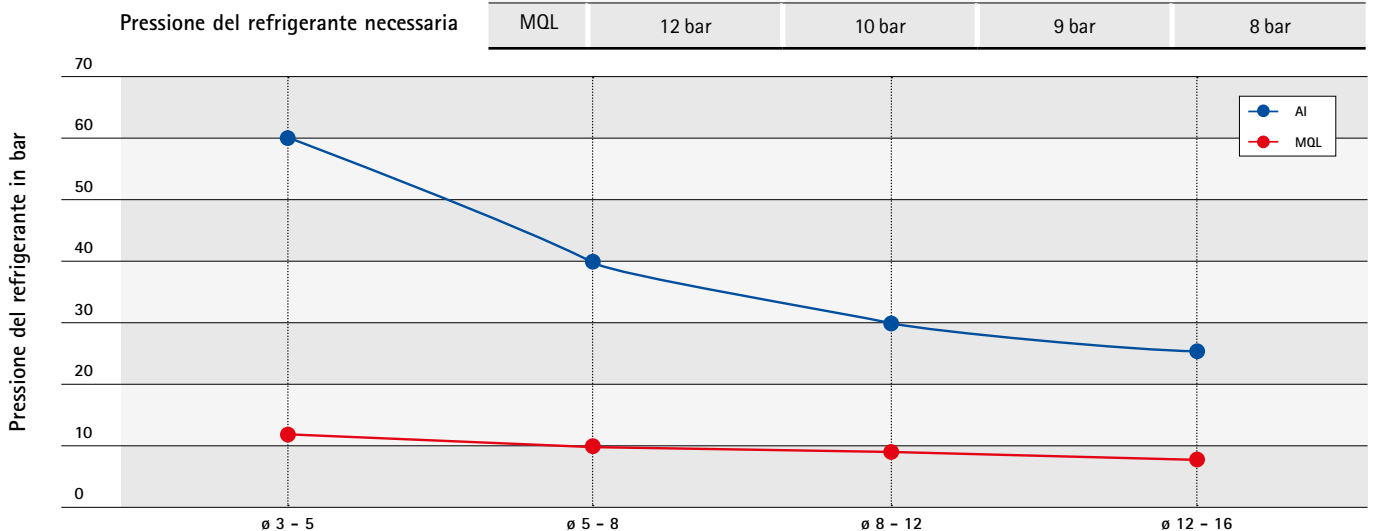

Foratura profonda 15xD - 30xD in due fasi:

Foratura profonda 15xD - 30xD con MEGA-Deep-Drill (SCD171) o MEGA-Deep-Drill-Alu (SCD181)

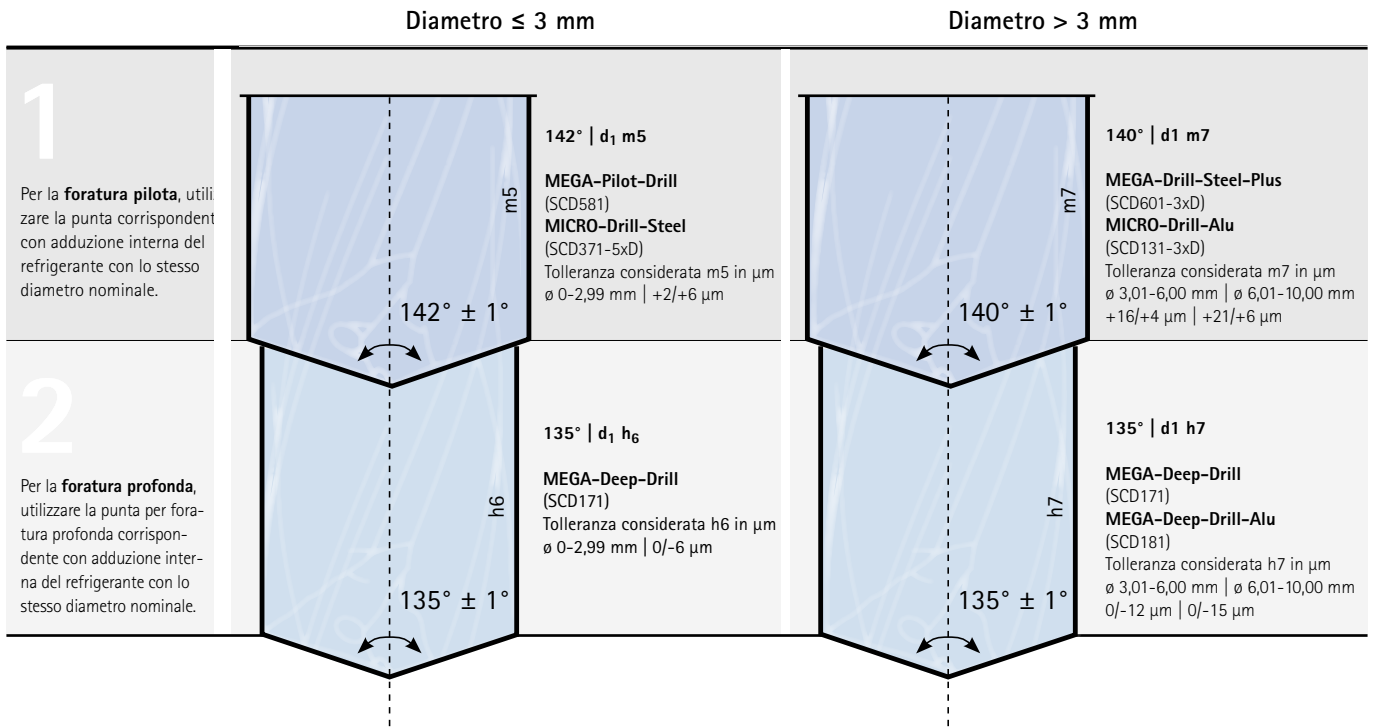

Foratura profonda 40xD in tre fasi:

Foratura profonda 40xD con MEGA-Deep-Drill (SCD171) o MEGA-Deep-Drill-Alu (SCD181)

Design ottimale per un processo di lavorazione sicuro.

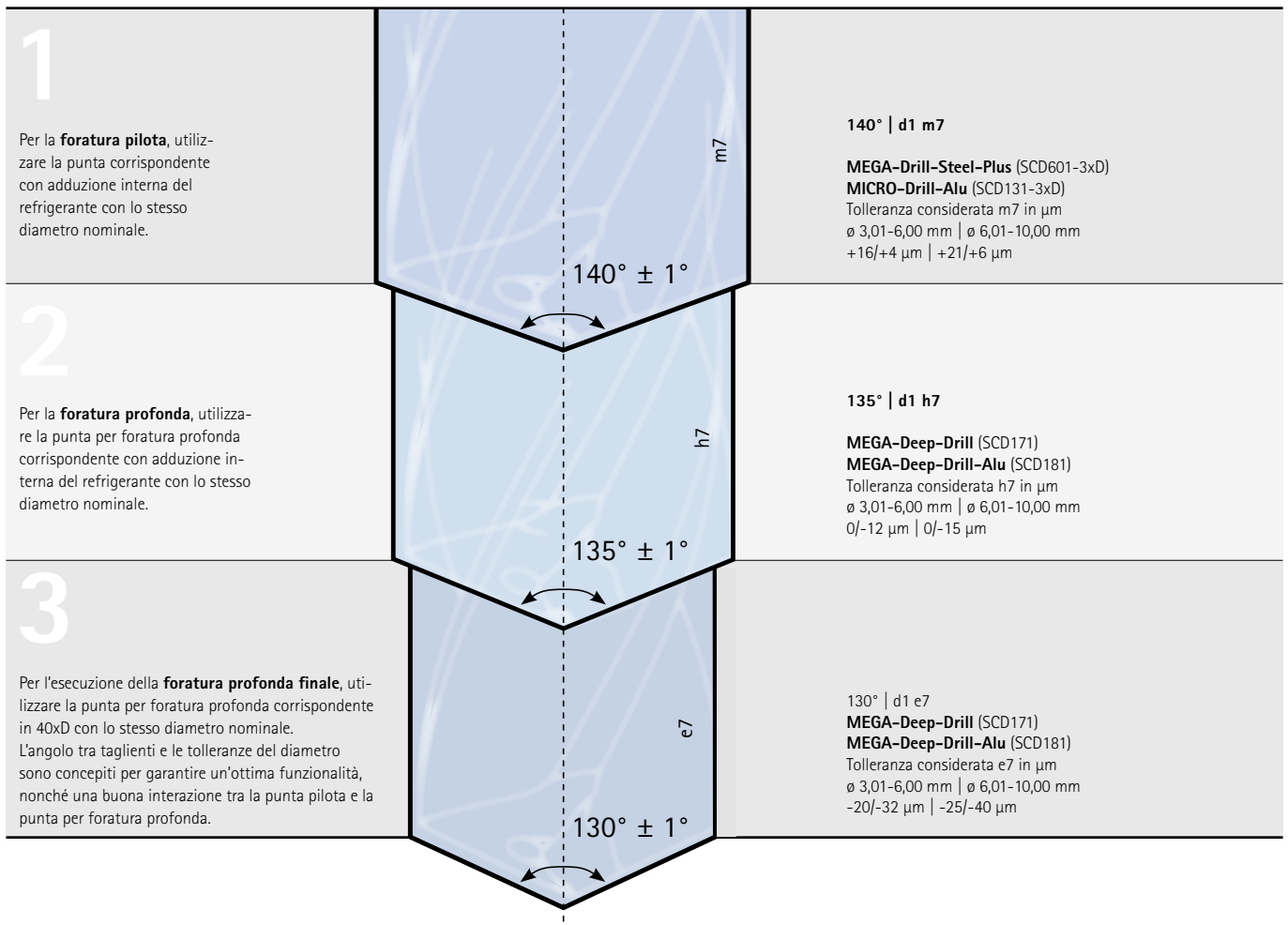

Indicazioni per l'applicazione di punte con inserto a fissaggio meccanico

NOTE

- Lunghezza massima utensile 5xD
- Nel caso di impiego di punte di foratura con un rapporto lunghezza/diametro maggiore di tre, sia per l'inizio della foratura che per l'uscita della punta dal foro si consigliano le seguenti riduzioni relativamente alla velocità di taglio v_c e all'avanzamento f :
 - 3xD: v_c -20% | f -30%
 - 4xD: v_c -30% | f -40%
 - 5xD: v_c -40% | f -50%



In condizioni ideali, la foratura iniziale avviene su materiale spianato, svasato o pre-fresato. Diversamente, è necessario ridurre l'avanzamento tra il 30% e il 60%:

- Foratura pilota e uscita della punta da superfici oblique e concave
- Ingresso in fori obliqui
- Foratura a pacco
- Foratura pilota su superfici non piane
- Foratura pilota su angolo
- Foratura pilota su superficie bombata
- Foratura pilota su profilo appuntito
- Fori in sequenza con sovrapposizioni
- Foratura pilota per centraggio
- Barenatura non disponibile



Foratura a pacco



Foratura pilota di una superficie bombata



Foro passante con foro obliquo



Foratura pilota di un profilo appuntito



Foratura pilota su superficie non piana

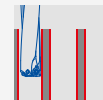

I fori in sequenza sono possibili con limitazioni a seconda del materiale

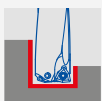

Foratura pilota su angolo



Foratura pilota per centraggio o scanalatura



Foratura pilota di superfici oblique / uscita foro obliqua



Barenatura non disponibile

Topografia sul fondo di un foro cieco

	Diametro D [mm]	A* [mm]	B* [mm]	C* [mm]
WOGT030206N-X40-HC698	16,00 - 20,90	3,61 (con \varnothing 16) - 3,52 (con \varnothing 20,9)	3,89 (con \varnothing 16) - 6,93 (con \varnothing 20,9)	0,40 (con \varnothing 16) - 0,71 (con \varnothing 20,9)
WOGT040206N-X40-HC698	21,00 - 25,90	4,06 (con \varnothing 21) - 4,00 (con \varnothing 25,9)	6,44 (con \varnothing 21) - 8,95 (con \varnothing 25,9)	0,76 (con \varnothing 21) - 0,98 (con \varnothing 25,9)
WOGT053006N-X40-HC698	26,00 - 30,90	5,18 (con \varnothing 26) - 5,11 (con \varnothing 30,9)	7,82 (con \varnothing 26) - 10,34 (con \varnothing 30,9)	0,81 (con \varnothing 26) - 1,04 (con \varnothing 30,9)
WOGT063008N-X40-HC698	31,00 - 44,90	6,41 (con \varnothing 31) - 6,28 (con \varnothing 44,9)	9,09 (con \varnothing 31) - 16,18 (con \varnothing 44,9)	1,06 (con \varnothing 31) - 1,62 (con \varnothing 44,9)
WOGT073808N-X40-HC698	45,00 - 54,90	7,70 (con \varnothing 45) - 7,63 (con \varnothing 54,9)	14,80 (con \varnothing 45) - 19,82 (con \varnothing 54,9)	1,57 (con \varnothing 45) - 7,63 (con \varnothing 54,9)

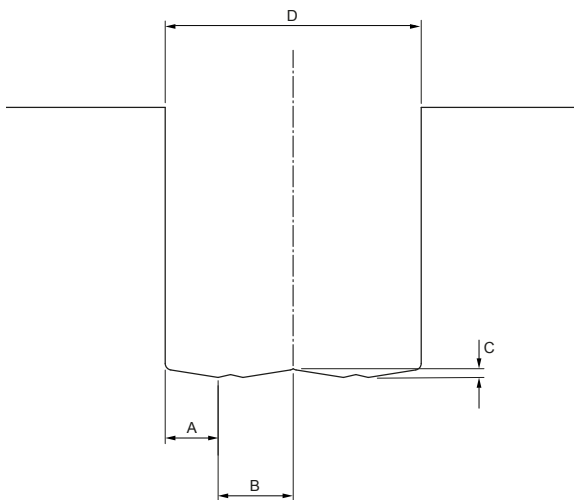
**Avvertenza di sicurezza:**

In caso di fori passanti, quando la punta fuoriesce si verifica il distacco del tappo del foro o di un dischetto con bordi affilati. In seguito a tale distacco, il tappo o il dischetto potrebbero essere scagliati via provocando danni o lesioni. Per evitare questo pericolo, è necessario adottare adeguate misure di protezione.

* A seconda della posizione di montaggio e dell'angolo di attacco degli inserti i valori A, B e C variano.

Indicazioni per l'utilizzo di punte con inserto QTD

Semplice sostituzione e regolazione dei taglienti QTD

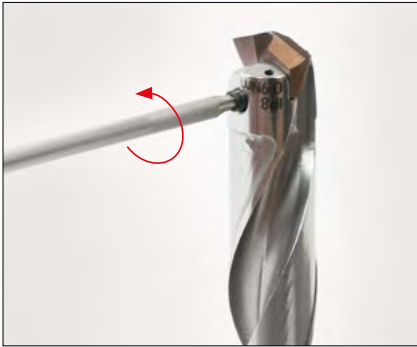

1. Utilizzando la chiave TORX® PLUS fornita in dotazione, allentare la vite speciale di serraggio ruotandola in senso antiorario.



2. Rimuovere l'inserto dalla rispettiva sede.



3. Pulire la sede dell'inserto con aria compressa.

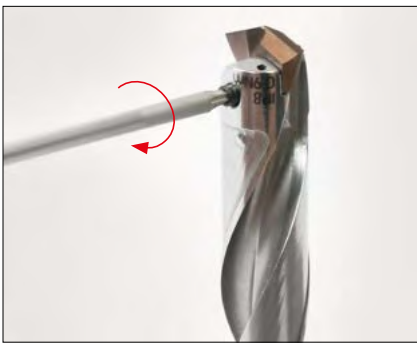

4. Inserire il nuovo inserto nella sua sede. Utilizzando la chiave TORX® PLUS in dotazione, stringere la vite speciale di serraggio ruotandola in senso orario.



5. Stringere la vite speciale di serraggio con la coppia di serraggio indicata.

NOTE

- Utilizzare esclusivamente viti originali!
- La vite speciale di serraggio deve essere sostituita al massimo dopo 5 cambi della testa di foratura
- La coppia di serraggio corretta è incisa sull'utensile

Risultato:

Ora l'inserto è stato completamente sostituito e l'utensile può essere utilizzato.



Appunti

Indicazioni per l'utilizzo della punta ad inserto intercambiabile TTD

Indicazioni per l'applicazione pratica

FORATURA PILOTA

- A partire da profondità di foratura $8xD$ è consigliabile eseguire un foro pilota
- Per la testina di foratura intercambiabile di tipo 02 si consiglia un foro pilota a partire da una profondità di foratura pari a $5xD$
- In caso di foro pilota con la testina di foratura intercambiabile di tipo 02 si consiglia una riduzione del 50% dell'avanzamento indicato
- In caso di foro pilota con le testine di foratura intercambiabili di tipo 01 e 03 possono essere utilizzati i valori di lavoro consigliati
- L'inserimento nel foro pilota avviene con la stessa geometria della testa di foratura e con valori di lavoro ridotti (raccomandazione: $v_c = 50\%$ e circa $f = 50\%$) fino a 1 mm prima del fondo del foro
- La foratura dopo il foro pilota avviene poi con i valori di lavoro consigliati (vedere pagine 224-227)

Utensile verticale

In caso di utensile verticale posizionare lo scarico del vano trucioli orizzontalmente, in modo da evitare che i trucioli formino un intasamento.

Situazione refrigerante

La pressione del refrigerante dipende dalla profondità di foratura:

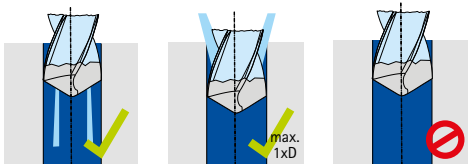

1xD: 8 bar | 3xD: 8 bar | 5xD: 12 bar | 8xD: 25 bar | 12xD: 40 bar

Massimo angolo di entrata e di uscita

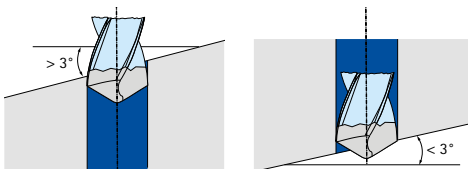

Condizioni di lavorazione

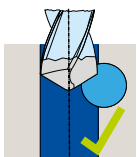

Foro fuori centro
Tagliante trasversale
ingranato

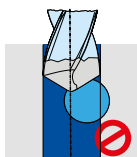

Foro fuori centro
Tagliante trasversale non
ingranato

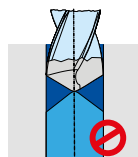

Sfondamento con
controforo

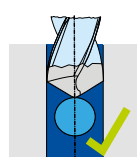

Foro centrale
 $e \ll D$

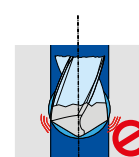

Foro centrale
 $e = D$

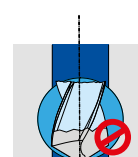

Foro centrale
 $e \gg D$

INDICAZIONI PER LA FORATURA CON SUPPORTO 12xD

- Con una profondità di foratura pari a $12xD$ è necessario eseguire un foro pilota
- La pressione del refrigerante deve corrispondere ad almeno 40 bar
- Nella lavorazione di materiali in acciaio potrebbe essere necessaria l'asportazione dei trucioli
- In caso di utensile azionato è possibile l'impiego sul tornio
- Si consiglia di aumentare la velocità di taglio del 30% rispetto al valore standard

Foro passante

All'uscita del foro si consiglia di non ridurre i parametri di lavorazione.

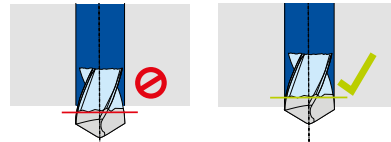

Precisione di concentricità

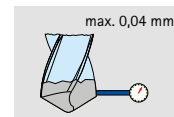
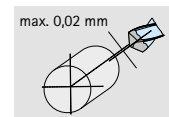

Niente corsa rapida in fase di estrazione

Per la velocità di estrazione si consiglia il quintuplo del valore della velocità di avanzamento.

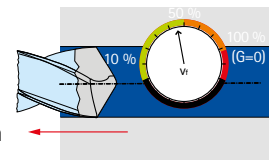

Montaggio

Rimuovere la testa di foratura

1. Ad ogni cambio della testa di foratura controllare che la vite di serraggio faccia sempre resistenza. Se la vite di serraggio si allenta con troppa facilità, deve essere sostituita. Utilizzare esclusivamente viti di serraggio originali!

Nota:

La vite speciale di serraggio deve essere sostituita al massimo dopo 8 cambi della testa di foratura.



2. Allentare la vite di serraggio utilizzando la chiave a brugola appositamente fornita.



3. Sfilare la testa di foratura dalla dentatura.

Serrare la testa di foratura



1. Pulire l'innesto TTS del supporto con una spazzola.



2. Inserire la nuova testa di foratura sul supporto.
3. Serrare a mano la vite di serraggio ruotandola in senso orario.

Nota:

Assicurarsi che l'ausilio per il posizionamento della testa di foratura combaci e si innesti con l'ausilio per il posizionamento del supporto, e assicurarsi anche che la scanalatura per i trucioli combaci con la dentatura della testa di foratura e del supporto.

Coppie di serraggio della vite di bloccaggio

Gamma di diametri [mm]	Porta-testa intercambiabile con filettatura	Larghezza tra le piastre	Trasmissibile ammissibile Coppia di serraggio [Nm]
12,00 - 13,49	M2,5	1,3	1,0
13,50 - 16,49	M3	1,5	1,3
16,50 - 24,49	M4x0,5	2	3,5
24,50 - 32,49	M5x0,5	2,5	4,0
32,50 - 41,49	M6x0,5	3	6,0
41,50 - 45,49	M8x1	4	10,0

Indicazioni per l'utilizzo della punta ad inserto intercambiabile TTD-Tritan

Montaggio utensile

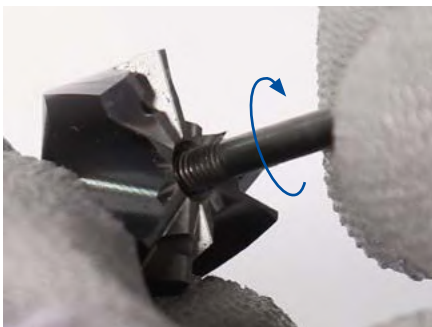

1. Inserire e avvitare la vite speciale di serraggio

Inserire la vite speciale di serraggio nel foro della testina di foratura intercambiabile con il lato filettato piccolo in avanti. Quindi avvitare la vite speciale di serraggio in senso orario fino all'arresto.



2. Pulizia con aria compressa

Pulire il supporto per testina intercambiabile e la testina di foratura intercambiabile con aria compressa.

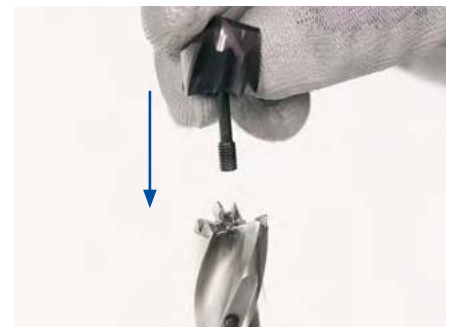

3. Innestare la testina di foratura intercambiabile

Innestare la testina di foratura intercambiabile sul supporto per testina intercambiabile.

Nota:

Allo stato di consegna, la vite speciale di serraggio è già montata sulla testina di foratura intercambiabile. Qualora fosse invece libera, la vite speciale di serraggio può essere nuovamente montata sulla testina di foratura intercambiabile semplicemente avvitandola nel foro.

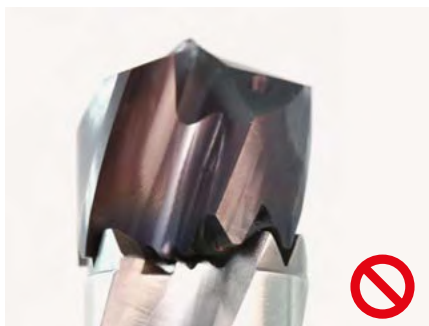
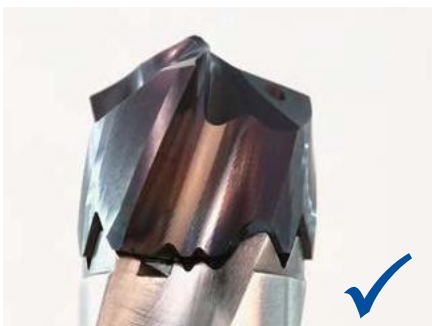

4. Verificare il posizionamento della testina di foratura

Controllare che la scanalatura per trucioli e la dentatura della testina di foratura intercambiabile e del supporto per testina intercambiabile combacino. Qualora non fossero allineate, ruotare la testina di foratura intercambiabile fino a far combaciare la scanalatura per trucioli e la dentatura.

Risultato:

La scanalatura per trucioli e la dentatura combaciano (sinistra) | non combaciano (destra)



- 1 Impugnatura per chiave TORX®
- 2 Supporto per testina intercambiabile TTS
- 3 Chiave TORX®
- 4 Testina di foratura intercambiabile con vite speciali di serraggio



5. Stringere la vite speciale di serraggio fino all'arresto

Premere leggermente la testina di foratura intercambiabile contro il suo supporto, in modo che mantenga la posizione innestata. Quindi inserire la chiave TORX® nel foro centrale del supporto per testina intercambiabile, fino al foro filettato della vite speciale di serraggio. Infine stringere a mano la vite speciale di serraggio mediante la chiave TORX®, avvitandola in senso orario fino all'arresto.



6. Stringere la vite speciale di serraggio con la coppia di serraggio

Utilizzare una chiave dinamometrica adatta con inserto a brugola in abbinamento alla chiave TORX® per stringere la vite speciale di serraggio con la coppia di serraggio indicata.

Nota:

La coppia di serraggio stabilita per la vite speciale di serraggio è riportata sul lato inferiore del supporto per testina intercambiabile.

Risultato:

La vite speciale di serraggio è stretta con la coppia di serraggio indicata e la testina di foratura intercambiabile è solidamente collegata al suo supporto. Il processo di montaggio è terminato.

Fornitura:

- 1 Impugnatura per chiave TORX®
- 2 Supporto per testina intercambiabile TTS
- 3 Chiave TORX®

Coppie di serraggio delle viti speciali di serraggio

Range di diametro [mm]	Filettatura Supporto per testina intercambiabile	Misura TORX®	Coppia di serraggio trasmissibile consentita [Nm]
12,00 - 13,99	M3 x 0,5	T6	0,40
14,00 - 17,49	M3,5 x 0,6	T7	0,70
17,50 - 19,49	M4 x 0,7	T8	1,30
19,50 - 24,49	M5 x 0,8	T10	2,00
24,50 - 28,49	M6 x 1,0	T15	3,10
28,50 - 32,49	M6 x 1,0	T15	5,60

Geometrie di imbocco e angoli di spoglia

Alesatori a più taglienti

Serie FXR, MOR, MPR, HPR

Imbocco

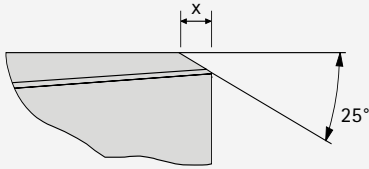
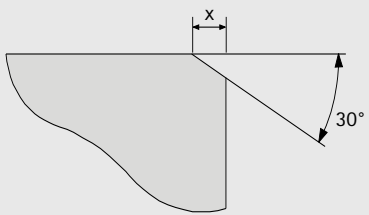
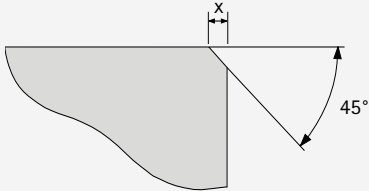
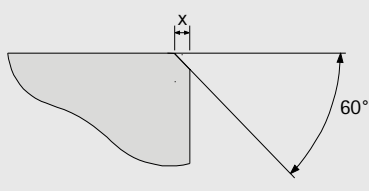
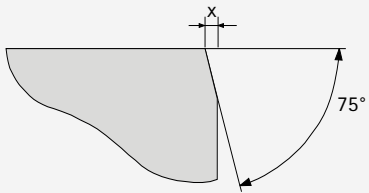
Geometria	Geometria di imbocco	
	Denominazione	Geometria
	ML	25°
	ME	30°
	MF	
	MG	
	MY	
	MC	45°
	MO	
	MU	
	MV	60°
	MT	
	MA	75°

Forma del truciolo/Angolo di spoglia

Angolo di spoglia	
Denominazione	Angolo
0A	0°
1 F	5°
1G	6°
1M	13°
2A	0° (per foro cieco)
2G	6° (per foro cieco)
3C	-2°

Spiegazione dei materiali da taglio	
Denominazione	Spiegazione
HU	Metallo duro non rivestito
HP	metallo duro rivestito in PVD
HC	Metallo duro rivestito in CVD
CU	Cermet non rivestito
CP	Cermet rivestito in PVD
PU	PCD

x = lunghezza
imbocco

Riepilogo serie | Range di diametro | Denominazione imbocco | Lunghezza imbocco

Serie	Denominazione imbocco	Range di diametro	Lunghezza imbocco x
FXR	MC	2,81 - 3,35	0,30
		3,36 - 4,05	0,40
		4,06 - 5,60	0,50
		5,61 - 6,60	0,60
		6,61 - 7,60	0,70
		7,61 - 11,60	0,80
		11,61 - 20,10	1,00
	MF	2,81 - 3,70	0,70
		3,71 - 6,20	0,90
		6,21 - 12,20	1,20
		12,21 - 20,20	1,50
	MG	2,81 - 3,70	0,70
		3,71 - 6,20	0,90
		6,21 - 12,20	1,20
		12,21 - 20,20	1,50
	MT	2,81 - 6,20	0,30
		6,21 - 10,70	0,40
		10,71 - 16,20	0,50
		16,21 - 20,20	0,60
	MV	2,81 - 6,20	0,30
		6,21 - 10,70	0,40
		10,71 - 16,20	0,50
		16,21 - 20,20	0,60

Serie	Denominazione imbocco	Range di diametro	Lunghezza imbocco x
MOR	MY	7,70 - 40,20	1,00
	MU	7,70 - 40,20	0,60
MRP	MG	3,85 - 6,20	0,90
		6,21 - 10,70	1,20
		10,71 - 20,20	1,50
		20,21 - 40,20	1,50
	MV	3,85 - 6,20	0,30
		6,21 - 10,70	0,40
		10,71 - 20,20	0,50
		20,21 - 26,20	0,60
	26,21 - 40,20	0,80	
HPR	MA	7,00 - 65,00	0,40
	MC	7,00 - 65,00	0,55
	ME	7,00 - 65,00	1,40
	MF	7,00 - 65,00	1,40
	ML	7,00 - 65,00	1,00
	MO	7,00 - 65,00	0,60

Indicazioni per l'utilizzo del sistema HFS®

Sistema HFS® MAPAL con serraggio assiale

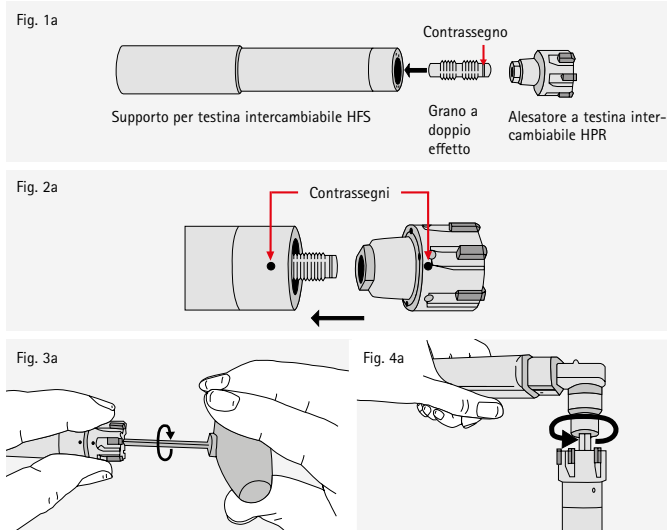

Sistema HFS® MAPAL con serraggio radiale

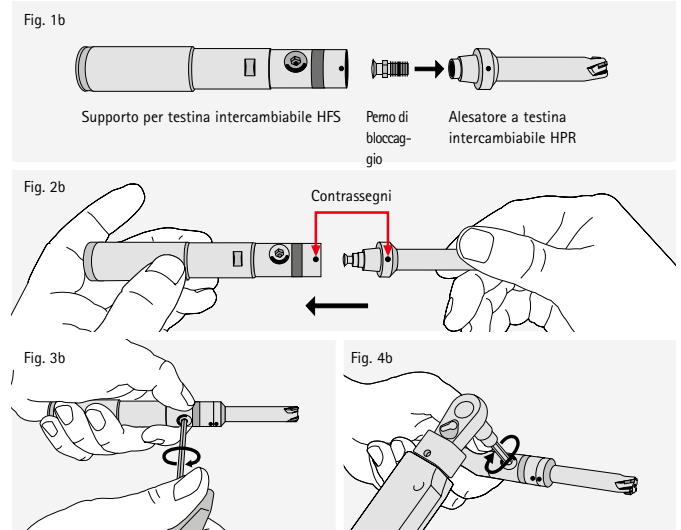

Pulizia

Pulire tutti i singoli elementi ed assicurarsi che il cono interno ed esterno, nonché la superficie piana del cono HFS siano privi di corpi estranei (ad es. trucioli). Per la pulizia del cono interno raccomandiamo l'apposito dispositivo di pulizia (vedere pagina 474).

Serraggio

- Inserire la parte terminale dell'grano a doppio effetto senza contrassegno nel supporto per testina intercambiabile HFS, senza però avvitare (vedere Fig. 1a).
- Posizionare l'alesatore a testina intercambiabile HPR sul grano a doppio effetto. In questa fase allineare il contrassegno presente sull'alesatore a testina intercambiabile HPR e quello sul supporto per testina intercambiabile HFS: "punto su punto" (vedere Fig. 2a). Quindi inserire completamente l'alesatore a testina intercambiabile HPR nel supporto per testina intercambiabile HFS e tenere fermi entrambi gli elementi.
- Avvitare l'alesatore a testina intercambiabile HPR sul supporto per testina intercambiabile HFS utilizzando una chiave a brugola, stringendo completamente. Assicurarsi che i contrassegni siano allineati e che la superficie piana aderisca bene (vedere Fig. 3a). **Nota:** HPR 100, 110, 150 vengono serrati tramite l'alesatore (direzione di rotazione in senso orario). HPR 130, 131, 180 vengono serrati tramite il supporto (direzione di rotazione in senso antiorario). Le direzioni di rotazione sono indicate sul supporto.
- Nota:** I supporti per testina intercambiabile HFS recano una scritta che indica la coppia di serraggio necessaria. Serrare l'alesatore a testina intercambiabile HPR utilizzando una chiave dinamometrica e ruotando in senso orario (vedere Fig. 4a).

Serraggio

- Avvitare il perno di bloccaggio con il lato filettato nell'alesatore a testina intercambiabile HPR con filettatura sinistra (vedere Fig. 1b).
- Inserire completamente l'alesatore a testina intercambiabile HPR nel supporto per testina intercambiabile HFS. In questa fase allineare il contrassegno presente sull'alesatore a testina intercambiabile HPR e quello sul supporto per testina intercambiabile HFS: "punto su punto" (vedere Fig. 2b). Quindi tenere fermi entrambi gli elementi.
- Ruotare il perno di serraggio in senso orario utilizzando una chiave a brugola (vedere Fig. 3b). La direzione di rotazione è indicata sul supporto per testina intercambiabile HFS.
- Nota:** I supporti per testina intercambiabile HFS recano una scritta che indica la coppia di serraggio necessaria. Serrare l'alesatore a testina intercambiabile HPR utilizzando una chiave dinamometrica e ruotando in senso orario (vedere Fig. 4b).

Dimensione attacco HFS	Coppia di serraggio [Nm]	
	assiale	radiale
10	4	-
12	6	7
14	6	7
16	15	12
20	15	12
24	20	-

Allentamento

- Nota:** La direzione di rotazione per allentare l'alesatore a testina intercambiabile HPR è in senso opposto al senso di rotazione del procedimento di serraggio. Per allentare l'alesatore a testina intercambiabile HPR ruotare il grano a doppio effetto utilizzando una chiave a brugola.
- Rimuovere l'alesatore a testina intercambiabile HPR.

Allentamento

- Per allentare l'alesatore ruotare il perno di serraggio in senso antiorario fino all'arresto, utilizzando una chiave a brugola.
→ L'alesatore a testina intercambiabile HPR viene espulso e può essere rimosso.

Settaggio dell'alesatore a testina intercambiabile HPR con regolazione fine

- Nota:** La coppia di taglianti posta di fronte, a prolungamento dei punti di contrassegno rotondi presso il supporto per testina intercambiabile HFS e l'alesatore a testina intercambiabile HPR, serve come riferimento per la misurazione e la regolazione del diametro utensile. Fissare l'alesatore a testina intercambiabile HPR nel supporto per testina intercambiabile HFS.
- Regolare il diametro utensile desiderato mediante la vite di misurazione con indicatore fine. Quindi accostare la vite di misurazione con indicatore fine ai taglianti di riferimento.
- Accostare la chiave TORX® alla vite di regolazione e ruotarla lentamente in senso orario. Regolare l'alesatore a testina intercambiabile HPR sulla misura desiderata.



In caso di varianti HPR con sistema di regolazione tenere in considerazione quanto segue:

In caso di alesatori a testina intercambiabile HPR con regolazione fine, fino a \varnothing 30 mm e con dimensione HFS da 12 a 20, il serraggio dell'alesatore a testina intercambiabile HPR è possibile solo in senso radiale. A partire da \varnothing 30 mm e dimensione HFS 24 l'alesatore a testina intercambiabile HPR può essere serrato anche mediante il grano a doppio effetto.

Adduzione del refrigerante per sistema HFS®

Per sfruttare appieno le prestazioni degli alesatori HPR, le diverse serie di testine intercambiabili necessitano di un'adduzione del refrigerante idonea. La differenza tra i componenti sta nel grano a doppio effetto o nel perno di bloccaggio. A seconda delle varianti di testina, questi elementi vengono utilizzati con o senza adduzione per il refrigerante, in modo che sia garantito un apporto diretto di refrigerante tramite l'innesto fino al tagliente.

Nota:

Per tutti i supporti con dimensione HFS 12, la fornitura comprende sempre entrambe le versioni. In fase di montaggio occorre quindi prestare attenzione a scegliere il sistema adatto alla testina intercambiabile utilizzata. (vedere Fig. in basso)

Adduzione del refrigerante senza passaggio centrale

Gli alesatori devono essere montati senza adduzione centrale per il refrigerante.

Il trasferimento del refrigerante dal supporto alla testina intercambiabile avviene tramite la superficie piana.



Adduzione del refrigerante con passaggio centrale

Tutti gli alesatori elencati devono essere montati con adduzione centrale per il refrigerante.

Il trasferimento del refrigerante avviene centralmente e inoltre, sia per il modello HPR150 che per l'HPR250, tramite la superficie piana.

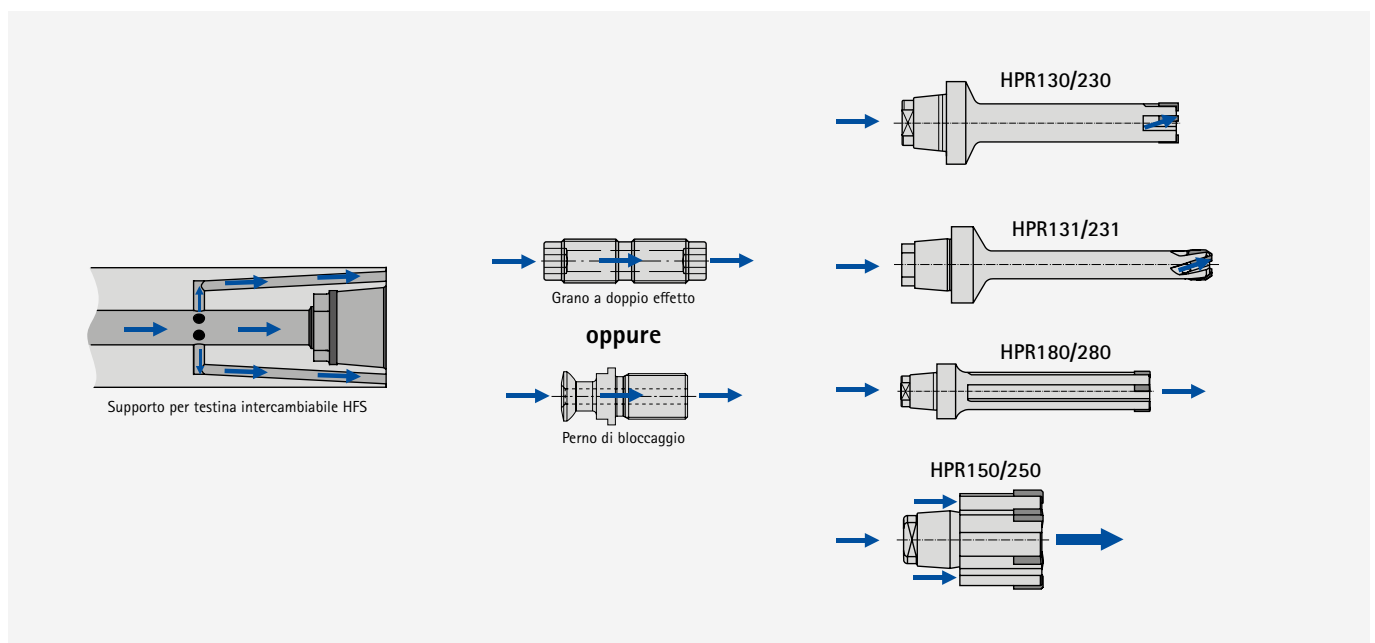

Indicazioni per l'utilizzo HPR400

Il modello HPR400 offre un sistema che consente al cliente di rinnovare l'equipaggiamento dell'utensile direttamente sul posto, in modo rapido e conveniente. Gli inserti intercambiabili vengono inseriti in senso assiale nella rispettiva sede e fissati stabilmente al corpo base mediante una vite TORX®. Resta sempre garantita la consueta qualità di lavorazione con precisione micrometrica.

Sostituzione degli inserti

Nota:

La sostituzione va effettuata in modo completo per tutti gli inserti!



1. Pulire l'HPR400 utilizzando aria compressa e un panno. Allentare la vite TORX® utilizzando un cacciavite TORX® adatto e girando la vite TORX® in senso antiorario. Una volta allentata, rimuovere la vite TORX®.



2. Far scorrere con cautela l'inserto in senso assiale fuori dalla rispettiva sede, quindi rimuoverlo. Rimuovere gli inserti restanti ripetendo le operazioni 1 e 2.



Nota:

Solo per personale appositamente formato.

3. Nota: Qualora si notino tracce di sporcizia, pulire le superfici di contatto degli inserti.

Pulire le sedi degli inserti con aria compressa. Passare quindi sulle sedi un apposito detergente a base di alcol.



4. Inserire il nuovo inserto nell'apposita sede fino a metà corsa. Quindi premere leggermente col pollice l'inserto nella rispettiva sede e contemporaneamente farlo scorrere in senso assiale verso il basso nella sua posizione finale. Per impedire che l'inserto possa fuoriuscire e cadere, fissarlo con la vite TORX®.



5. Nota: Serrare le viti TORX® solo mediante una chiave dinamometrica adatta.

Stringere la vite TORX® con una coppia di serraggio pari a 3,1 Nm.

Risultato:

Gli inserti sono stati interamente sostituiti e l'HPR400 è pronto per l'uso.

Indicazioni per l'utilizzo HPR400 plus

Gli inserti a quattro taglienti dell'HPR400 plus vengono prodotti con una precisione tale da consentirne la semplice sostituzione o l'agevole ribaltamento direttamente sul posto a cura dei collaboratori del cliente.



Sostituzione degli inserti

Requisito:

Prima di iniziare la sostituzione degli inserti, pulire l'utensile.

Nota:

Solo per personale appositamente formato.



1. Allentare la vite TORX® PLUS con un cacciavite idoneo ruotandola in senso antiorario. Quindi estrarre la vite TORX® PLUS.



2. Far scorrere delicatamente l'inserto in direzione assiale verso l'alto ed estrarlo facendolo fuoriuscire dalla rispettiva sede. Estrarre gli inserti restanti.



3. Pulire le sedi degli inserti con aria compressa, quindi passare un detergente a base di alcol. Pulire le superfici di contatto degli inserti con la pasta pulente.

Nota:

La sostituzione o il ribaltamento vanno effettuati in modo completo per tutti gli inserti!

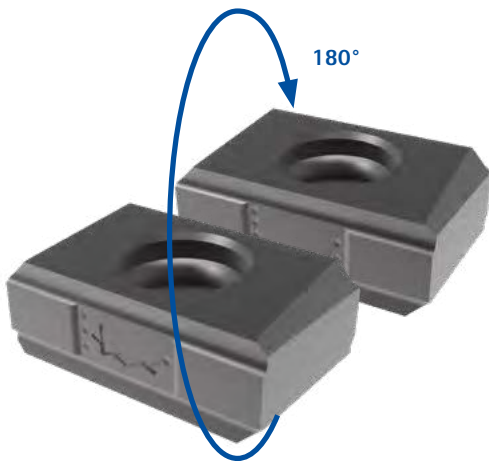

Nota:

Per il ribaltamento dell'inserto prestare attenzione alla sequenza dei taglienti considerando i relativi punti di contrassegno (da uno a quattro punti).



4. Inserire in sede l'inserto nuovo o ribaltato portandolo fino a metà corsa. Quindi premere leggermente col pollice l'inserto nella rispettiva sede e contemporaneamente farlo scorrere in senso assiale verso il basso. Fissare infine l'inserto mediante la vite TORX® PLUS.



5. Stringere la vite TORX® PLUS ruotandola in senso orario e applicando la coppia di serraggio indicata.

Nota:

Serrare le viti TORX® PLUS solo mediante una chiave dinamometrica adatta. La coppia di serraggio per le viti TORX® PLUS è pari a 3,5 Nm.

Risultato:

Gli inserti sono stati interamente sostituiti e l'utensile è pronto per l'uso.

Indicazioni sulla regolazione per alesatori WP a un tagliente

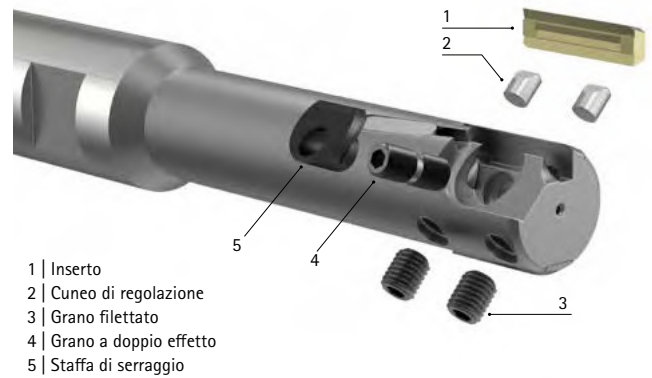

1. Ruotare i due grani filettati di $\frac{1}{2}$ giro in senso antiorario.



2. Allentare la staffa di serraggio: Ruotare il grano a doppio effetto su ambo i lati di 2-3 giri in senso antiorario (inserto rivolto verso il basso).



3. Rimuovere l'inserto.

4. Pulire l'inserto e la rispettiva sede.

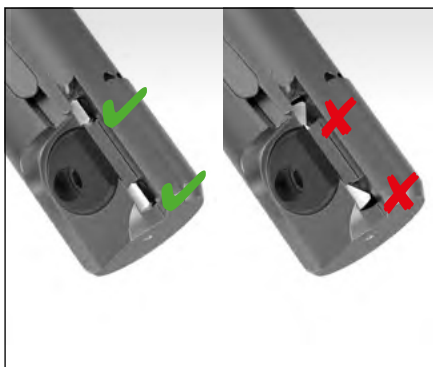

5. Verificare che il cuneo di regolazione sia in posizione diritta.

6. Inserire in sede l'inserto nuovo o girato.

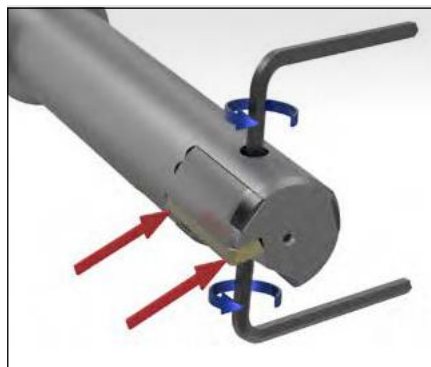

7. Tenere premuto l'inserto e stringere il grano a doppio effetto su entrambi i lati in senso orario alla coppia di serraggio richiesta.

8. Ruotare i due grani filettati di $\frac{1}{4}$ di giro in senso orario.

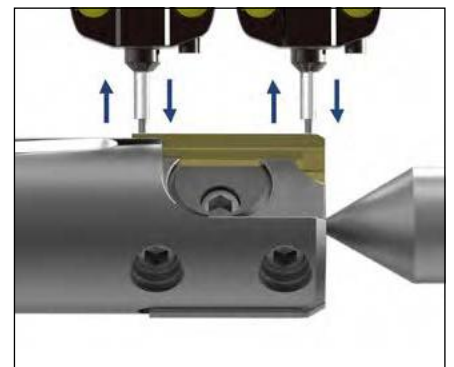

9. Settare la misura di regolazione anteriore e posteriore, a intervalli alternati, mediante i grani filettati. Rastrezione all'indietro circa $1 \mu\text{m}/\text{mm}$.

NOTA:

Per una panoramica delle coppie di serraggio in formato PDF si rimanda al sito web di MAPAL:

mapal.com/it-it/ → Mediateca → Istruzioni e indicazioni per l'utilizzo → Informazioni tecniche generali → Coppie di serraggio per viti MAPAL

Indicazioni sulla regolazione per alesatori a un tagliente HX

Dimensione 2 e dimensione 3

- | | |
|----------------------------|--------------------------|
| 1 Staffa di serraggio | 4 Cartuccia |
| 2 Grano a doppio effetto | 5 Cuneo di regolazione |
| 3 Inserto HX | 6 Grano filettato |

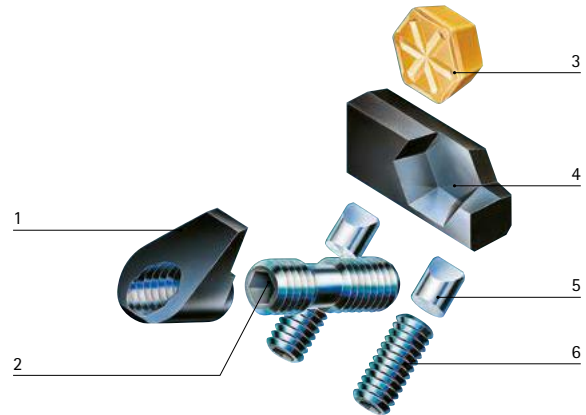

Sostituzione dell'inserto e regolazione

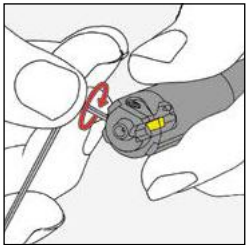

1. Ruotare i grani filettati anteriore e posteriore di mezzo giro verso sinistra.

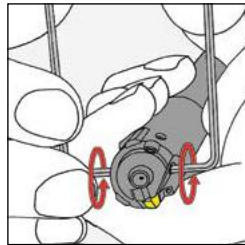

2. **Nota:** Per l'apertura è necessario utilizzare due chiavi. Per allentare l'inserto e la cartuccia, ruotare il grano a doppio effetto in senso orario e antiorario.

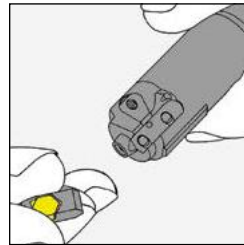

3. Estrarre l'inserto e la cartuccia. Pulire accuratamente l'inserto, la cartuccia e la sede dell'inserto (non utilizzare aria compressa, fare attenzione ai cunei di regolazione). Ruotare l'inserto di ulteriori 60° oppure inserire un nuovo inserto nella cartuccia. Montare nuovamente la cartuccia.

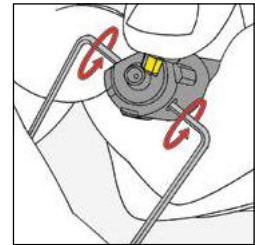

4. **Nota:** Per il serraggio è necessario utilizzare due chiavi. Premere l'inserto e la cartuccia contro l'arresto posteriore e il cuneo di regolazione. Ruotare il grano a doppio effetto da sopra verso destra e da sotto verso sinistra, quindi serrare.

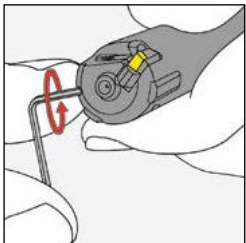

5. Per una regolazione grossolana, ruotare i grani filettati anteriore e posteriore di un quarto di giro verso destra.

Per una maggiore semplicità di utilizzo e una sicurezza di regolazione garantita, consigliamo di utilizzare un dispositivo di regolazione MAPAL.

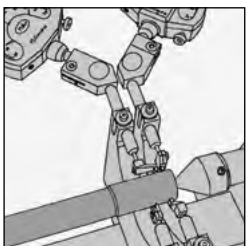

7. Calibrare il MASTERSET MAPAL con la spina di regolazione (da ordinare separatamente). La spina di regolazione ha la misura minima del foro.

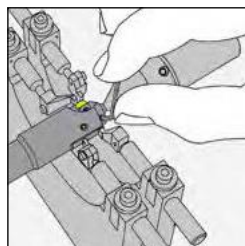

8. Settare la misura di regolazione anteriore e posteriore, a intervalli alternati, mediante i grani filettati. La rastremazione all'indietro va da 0,005 a 0,010 mm circa.

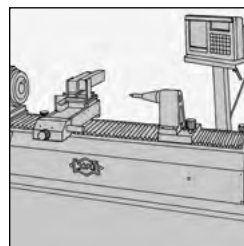

9. MAPAL UNISSET: Per una comoda regolazione degli alesatori, MAPAL propone dei dispositivi di regolazione elettronici in versione verticale oppure orizzontale. Ulteriori informazioni in proposito sono riportate nel catalogo "PRESETTAGGIO | MISURAZIONE | STOCCAGGIO".

Per indicazioni dettagliate sulla regolazione consultare le istruzioni per l'uso del dispositivo.

Indicazioni per l'utilizzo del sistema EasyAdjust

Sostituire e regolare l'inserto

Il sistema EasyAdjust consente una sostituzione nel contempo semplice e veloce dell'inserto. Per sostituire un inserto e regolarlo con precisione micrometrica sono necessari solo pochi, semplici passaggi.



1. Allentare il cono di regolazione mediante una chiave a brugola e ruotarlo di mezzo giro in senso antiorario.

Nota:

Utilizzo solo per personale appositamente formato.



2. **Nota:** Per l'operazione di allentamento sono necessarie due chiavi a brugola.

Per allentare la staffa di serraggio, ruotare la chiave a brugola 1 in senso antiorario e la chiave a brugola 2 in senso orario.



3. Spingere la cartuccia insieme al cono di regolazione in avanti, in direzione dell'utensile.



4. Estrarre l'inserto dalla cartuccia.



5. Sostituire o girare l'inserto. Quindi inserire l'inserto nella cartuccia.



6. **Nota:** Per l'operazione di serraggio sono necessarie due chiavi a brugola.

Per serrare la staffa di serraggio, ruotare la chiave a brugola 1 in senso orario e la chiave a brugola 2 in senso antiorario.



7. **Nota:** Proseguire con la misurazione della sporgenza oppure con la misurazione assoluta.

Serrare l'utensile nella sede di un apposito dispositivo di regolazione. Utilizzare il tastatore di misurazione per accostare il punto più alto del pattino di guida, quindi azzerare il valore di misurazione in questo punto.

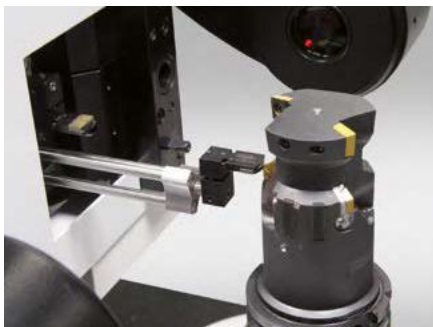

8. Utilizzare il tastatore di misurazione per accostare il punto più alto dell'inserto.



9. Regolare la misura della sporgenza o la misura assoluta dell'inserto: a tale scopo ruotare il grano filettato in senso orario con una chiave a brugola.

Risultato:

La misura della sporgenza o la misura assoluta dell'inserto desiderata è stata impostata.



Indicazioni per il montaggio e la regolazione dell'alesatore esterno con sistema EA



Sostituire l'inserto

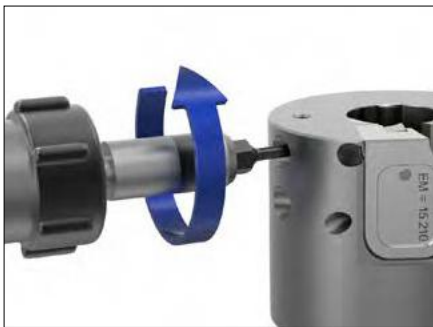

1. Ruotare le due viti di fissaggio TORX in senso antiorario e rimuovere la cartuccia.



2. Riportare l'inserto all'impostazione base: Ruotare la vite di regolazione di mezzo giro in senso antiorario.



3. Ruotare il grano a doppio effetto di 1,5 giri in senso antiorario.



4. Rimuovere l'inserto TEC. Pulire l'inserto TEC e la rispettiva sede.

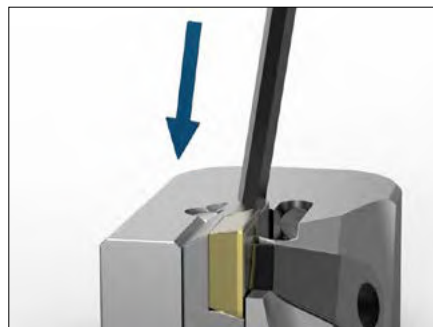

5. Inserire in sede l'inserto nuovo o girato prestando attenzione alla pressione assiale e radiale. Premere leggermente la cartuccia contro la direzione di regolazione.

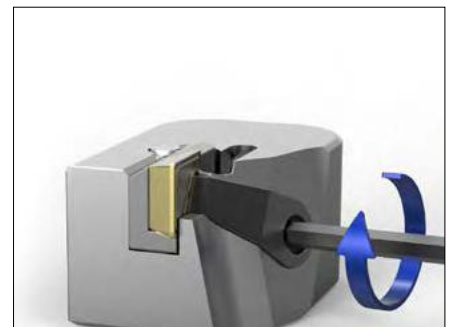

6. Serrare manualmente il grano a doppio effetto della staffa di serraggio procedendo in senso orario.

Regolazione dell'inserto



7. Impostare la misura finale in base a quanto riportato sulla cartuccia e resettare il tastatore.

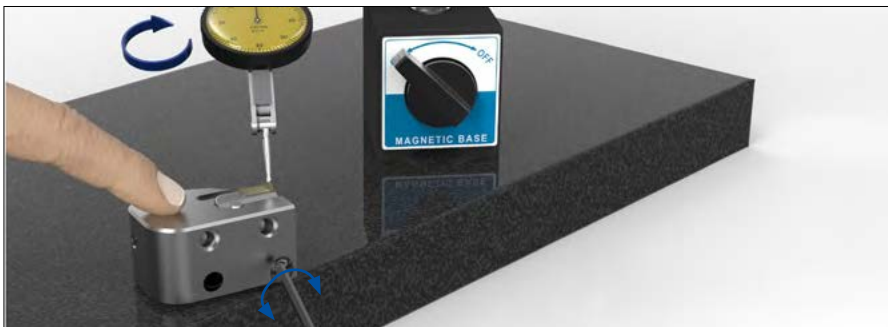

8. Portare il tastatore sul punto più elevato dell'inserto TEC. Girare la vite di regolazione in senso orario fino a quando l'indicatore del comparatore non si troverà sullo zero.

Montaggio



9. Inserire la cartuccia nell'apposita sede. Stringere leggermente entrambe le viti di fissaggio. Serrare quindi le viti di fissaggio Torx a 2,8 Nm.

Risoluzione dei problemi per utensili per microperforazione e alesatori fissi

Foro non circolare - irregolare

Cause		Soluzione	
Utensile per microperforazione	Alesatore a più taglienti		
Sporgenza impostata eccessiva	-	Verificare/regolare le impostazioni dell'utensile	
-	fz troppo piccolo / vc troppo grande	Adeguare i parametri di lavorazione (raccomandazioni v. catalogo)	
Anticipo eccessivo	-	Verificare l'anticipo	

Foro non circolare - ripetitivo

Cause		Soluzione	
Utensile per microperforazione	Alesatore a più taglienti		
Componente bloccato (poligono, tipicamente mandrino a ganaschia)		Verificare serraggio/pressione di serraggio	
Componente con sezioni asimmetriche		Ridurre la pressione di taglio (maggiore rastremazione, minore numero di denti, imbocco più inclinato, minore avanzamento)	

Foro troppo grande

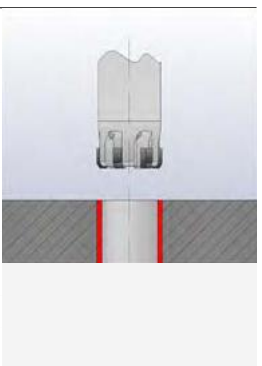
Cause		Soluzione	
Utensile per microperforazione	Alesatore a più taglienti		
Errore di concentricità troppo grande		Verificare la concentricità / Utilizzare adattatore di allineamento	
Cattivo posizionamento		Controllare la posizione di foratura	
Tagliente di riporto		Aumentare vc, controllare lubrorefrigerante / caratteristiche del materiale da taglio / geometria di imbocco (raccomandazioni v. catalogo)	
Vibrazioni/rumori		Adeguare parametri di taglio/sovrametallo (raccomandazioni v. catalogo)	
Sporgenza eccessiva	-	Verificare/correggere il diametro impostato	
-	Diametro utensile non ok	Verificare il diametro	

Foro troppo piccolo

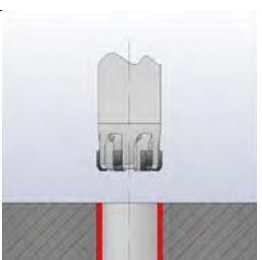
Cause		Soluzione	
Utensile per microperforazione	Alesatore a più taglienti		
Tagliente/i usurato/i		Cambiare/Riaffilare	
Verificare la profondità di passata assiale ap (lavorazione preliminare)		Adeguare la profondità di passata assiale, raccomandazioni v. catalogo	
Componenti a sezione limitata (deformazione elastica del componente)		Ridurre le forze di taglio (aumentare rastremazione, ridurre numero di denti, imbocco più inclinato, minore avanzamento)	
Sporgenza insufficiente	-	Verificare/regolare le impostazioni	

Ingresso foro conico | Uscita foro conica

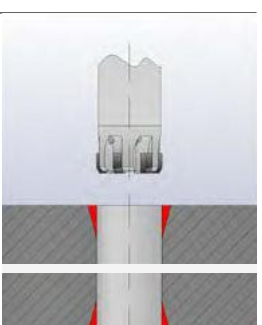
Cause		Soluzione	
Utensile per microperforazione	Alesatore a più taglienti		
Errore di concentricità troppo grande		Verificare la concentricità / Utilizzare adattatore di allineamento	
Problema di posizionamento / Disassamento		Verificare la posizione per la lavorazione preliminare e la linearità dell'asse	
-	Tragitto eccessivo	Oltrepassare max. lunghezza di imbocco +1 mm presso l'uscita del foro	
Anticipo eccessivo	-	Verificare l'anticipo	
Pressione lubrorefrigerante eccessiva		Ridurre la pressione del lubrorefrigerante	

Superficie del foro non ok | irregolare

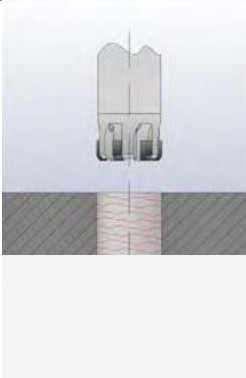
Cause		Soluzione	
Utensile per microperforazione	Alesatore a più taglienti		
Struttura / difetti macroscopici		Verificare e se necessario sostituire utensile/taglienti Parametri di lavorazione v. catalogo	
Sovrametallo troppo esiguo		Verificare lavorazione preliminare e sovrmetalto	
Scarsa lubrificazione/refrigerazione		Controllare lubrificazione minima, lubrorefrigerante e livello olio Controllare idoneità lubrorefrigerante per il tipo di lavorazione	
Anomalia in asportazione dei trucioli Usura		Aumentare pressione lubrorefrigerante / Adeguare geometria del tagliente Sostituire taglienti/utensile	
Sbilanciamento		Verificare che la combinazione attacco/adattatore e utensile sia sufficientemente equilibrata	

Superficie del foro non ok | regolare

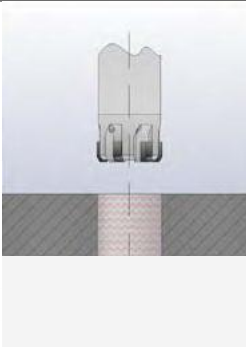
Cause		Soluzione	
Utensile per microperforazione	Alesatore a più taglienti		
Disassamento/Errato posizionamento fz troppo piccolo / vc troppo grande		Verificare l'allineamento dei fori e la posizione Adeguare i parametri di lavorazione (raccomandazioni v. catalogo)	
Rapporto diametro/lunghezza critico		Verificare il rapporto diametro/lunghezza critico	
Interferenze mandrino e unità di trasmissione		Modificare i parametri di taglio, verificare le caratteristiche dell'imbocco (raccomandazioni v. catalogo)	
Sbilanciamento		La combinazione attacco/adattatore e utensile è sufficientemente equilibrata?	
Rastremazione troppo piccola		Verificare/regolare	
Sporgenza eccessiva		Verificare/regolare	

Traiettoria del foro / Forma cilindrica non ok

Cause		Soluzione	
Utensile per microperforazione	Alesatore a più taglienti		
Lavorazione preliminare errata		Contattare reparto/esperto, verificare/regolare	
Geometria di imbocco o utensile non idonei		Contattare reparto/esperto	
Strategia di lavorazione non idonea		Contattare reparto/esperto	

Rottura completa geometria di imbocco – in generale rivolgersi a un esperto/collaboratore MAPAL

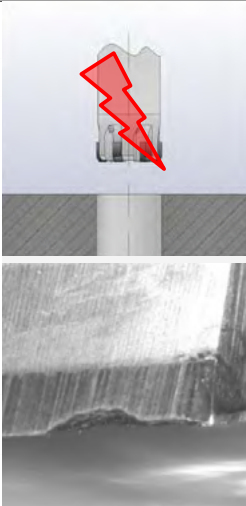
Cause		Soluzione	
Utensile per microperforazione	Alesatore a più taglienti		
Asportazione dei trucioli		Aumentare pressione lubrorefrigerante / geometria del tagliente	
Rastremazione troppo piccola/grande		Verificare/regolare	
Eccessivo sovrmetalto ap		Verificare/regolare	
Eccessiva usura		Sostituire taglienti/utensile	
Vibrazioni		Rilevare ed eliminare causa	
Parametri di lavorazione non ok		Adeguare i parametri di lavorazione (raccomandazioni v. catalogo)	
Anticipo eccessivo		Ridurre l'anticipo se necessario	

Formule di asportazione truciolo generali per barenatura

Velocità e avanzamento

Numero di giri	$n = \left[\frac{1}{\text{min}} \right]$	$n = \frac{v_c \cdot 1000}{\pi \cdot D_c}$
Velocità di taglio	$v_c = \left[\frac{\text{m}}{\text{min}} \right]$	$v_c = \frac{\pi \cdot D_c \cdot n}{1000}$
Velocità di avanzamento	$v_f = \left[\frac{\text{mm}}{\text{min}} \right]$	$v_f = f_z \cdot z \cdot n$
Avanzamento/dente	$f_z = [\text{mm}]$	$f_z = \frac{v_f}{z \cdot n}$
Avanzamento	$f = [\text{mm}]$	$f = f_z \cdot z$
Numero di taglienti	z	

Forza di taglio

Forza di taglio F_c	$F_c = A \cdot k_c = b \cdot h \cdot k_c$	F_c in N k_c in N/mm ²
Forza di taglio specifica	$k_c = \left[\frac{k_c \cdot 1.1}{h \cdot mc} \right]$	

Dimensioni di asportazione nella barenatura

Oltre alla forza di taglio specifica del materiale, la forza di asportazione truciolo è determinata sostanzialmente dalla sezione di asportazione A . Il valore di avanzamento per tagliente f_z e la profondità di passata assiale a_p sono misure importanti a questo proposito.

Vigono le seguenti relazioni:

Avanzamento	$f = [\text{mm}]$	$f = f_z \cdot z$
Angolo di regolazione	$\kappa = [^\circ]$	$\kappa = \frac{\sigma}{2}$
Larghezza di asportazione truciolo	$b = [\text{mm}]$	$b = \frac{a_p}{\sin \kappa}$
Spessore di asportazione truciolo	$h = [\text{mm}]$	$h = f_z \cdot \sin \kappa$
Profondità di passata assiale	$a_p = [\text{mm}]$	$a_p = \frac{(D - d)}{2}$

La figura mostra la sezione di asportazione A in barenatura.

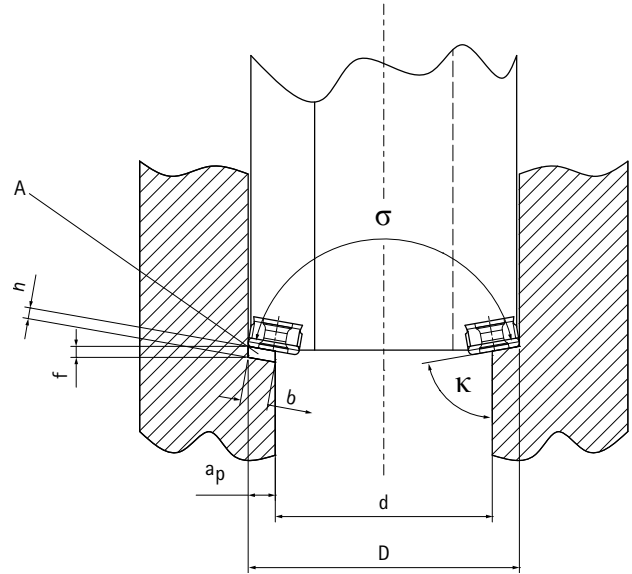

Sezione di asportazione truciolo per barenatura	$A = [\text{mm}^2]$	$A = \frac{(D - d) \cdot f_z}{2}$	oppure	$A = a_p \cdot f_z$
---	---------------------	-----------------------------------	--------	---------------------

Calcolo della forza di taglio per barenatura

Versione semplificata

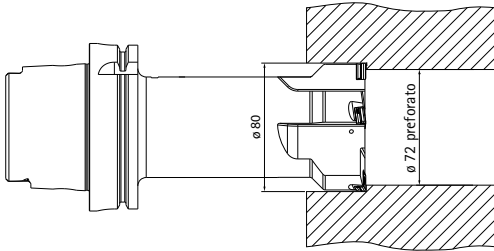

Esempio di calcolo:

Utensile di barenatura ø 80 mm;
Z = 5; ø preforato 72 mm, κ = 90°

Materiale: EN-GJL-250
k_{c1.1}* = 1160, M_c = 0,26
v_c = 200 m/min, f_z = 0,2 mm
Smussatura 30%

	Formula di base	Calcolo	Risultato
1. Numero di giri	$n = \frac{V_c \cdot 1000}{\pi \cdot D}$	$n = \frac{200 \cdot 1000}{\pi \cdot 80}$	n = 800 1/min
2. Profondità di passata assiale	$a_p = \frac{(D - d)}{2}$	$a_p = \frac{(80 - 72)}{2}$	a _p = 4 mm
3. Sezione di asportazione truciolo	$A = a_p \cdot f \cdot z$	$A = 4 \text{ mm} \cdot 0,2 \text{ mm} \cdot 5$	A = 4 mm ²
4. Spessore di asportazione truciolo	$h = f_z \cdot \sin \kappa$	$h = 0,2 \text{ mm} \cdot \sin 90^\circ$	h = 0,2 mm
5. Forza di taglio specifica senza fattore di smussatura	$k_c = \frac{k_{c1.1}}{h^{m_c}}$	$k_c = \frac{1160}{0,2^{0,26}}$	k _c = 1763 N/mm ² con smussatura 30%: 1763 N/mm ² × 1,3 = 2292 N/mm ²
6. Forza di taglio	$F_c = A \cdot k_c = b \cdot h \cdot k_c$	$F_c = 4 \text{ mm}^2 \cdot 2292 \text{ N/mm}^2$	F _c = 9,17 kN
7. Coppia di taglio d _m = diametro medio in metri	$M_c = F_c \cdot \frac{d_m}{2}$	$M_c = 9167,3 \text{ N} \cdot \frac{0,076 \text{ m}}{2}$	M _c = 348,3 Nm
8. Potenza di taglio	$P_c = \frac{2 \cdot \pi \cdot n \cdot M_c}{60s}$	$P_c = \frac{2 \cdot \pi \cdot 800 \text{ min}^{-1} \cdot 348,3 \text{ Nm}}{60s}$	P _c = 29,2 kW

* Valore dal calcolo della forza di taglio, WTO GmbH

Nota: Il valore di efficacia dell'azionamento del mandrino principale non è considerato. I relativi calcoli di potenza possono essere eseguiti da MAPAL.

Come scegliere una macchina utensile

Confronto con coppia e potenza della macchina utensile

Di seguito due diagrammi numero di giri/potenza.

A seconda della macchina devono essere stabiliti il numero di denti e i parametri di taglio.

Nell'esempio di calcolo la macchina con il mandrino motore non è idonea, poiché con un numero di giri pari a 800 min^{-1} si ottengono solo una coppia di 187 Nm e una potenza di circa 20 kW (Figura 1).

Soluzione:

Ridurre il numero di denti, ridurre la velocità di taglio e l'avanzamento, dividere il taglio su due utensili, oppure scegliere una macchina più potente (ad es. con mandrino di trasmissione, Figura 2).

Mandrino motore (Figura 1)

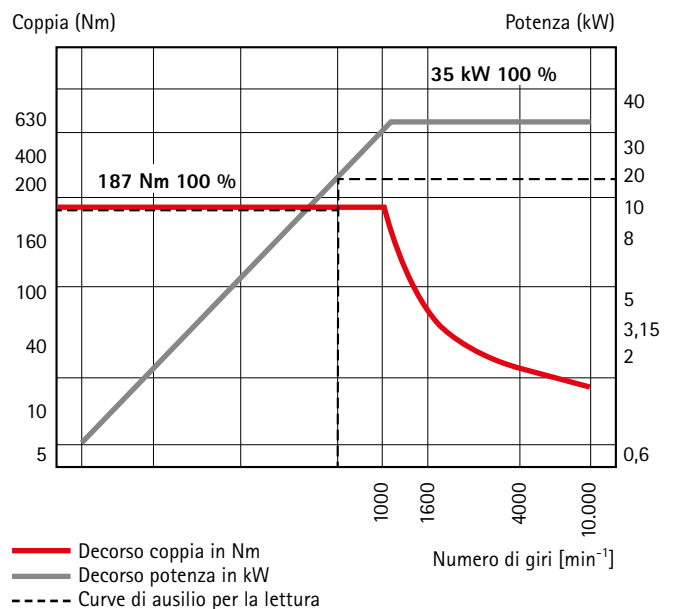

Mandrino di trasmissione (Figura 2)

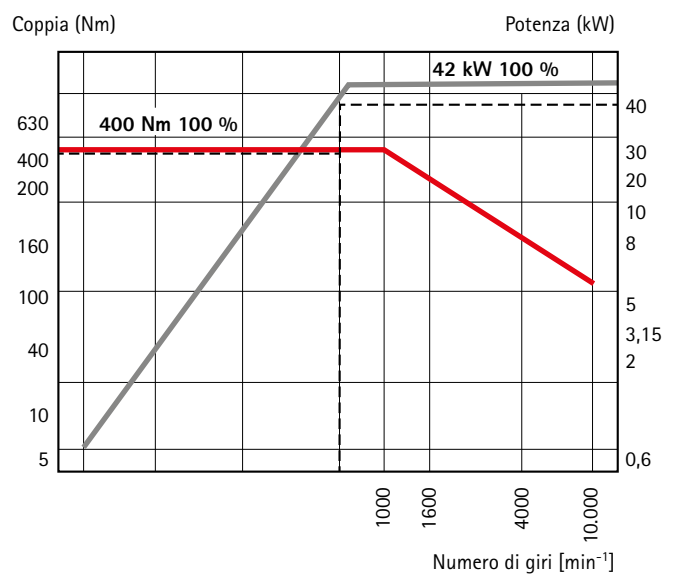

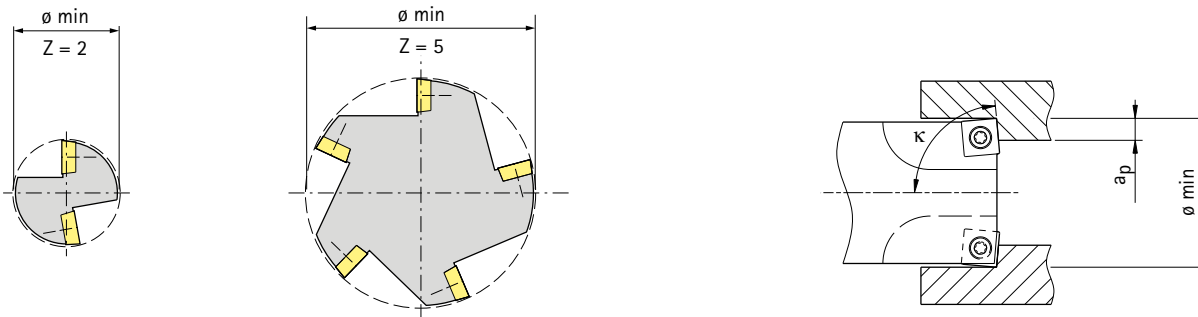

Valori orientativi del diametro minimo di barenatura – Radiale

A seconda del numero di denti e dell'inserto a fissaggio meccanico



Taglienti di barenatura radiali senza arrotondamento

Forma inserto	Dimensione inserto				Numeri di denti	Nota
	0603	09T3	1204			
S (90°)	Diametro minimo di barenatura con κ 85°					Adatto a foro passante
	17	25	28		1	
	17	25	31		2	
	23	32	39		3	
	31	43	53		4	
	51	63	73		5	
C (80°)	0602	09T3	1204			Indicato per spallamento retto
	Diametro minimo di barenatura con κ 90°					
	17	24	28		1	
	18	26	33		2	
	23	34	41		3	
	31	45	54		4	
49	63	77		5		
T (60°)	06T1	0902	1102	16T3		Applicabile in particolari condizioni per fori passanti e spallamento retto
	Diametro minimo di barenatura con κ 90°					
	15	17	17	24	1	
	18	21	24	37	2	
	21	25	28	43	3	
	27	34	37	57	4	
37	51	67	76	5		

Valori orientativi del diametro minimo di barenatura – Tangenziale

A seconda del numero di denti e dell'inserto a fissaggio meccanico

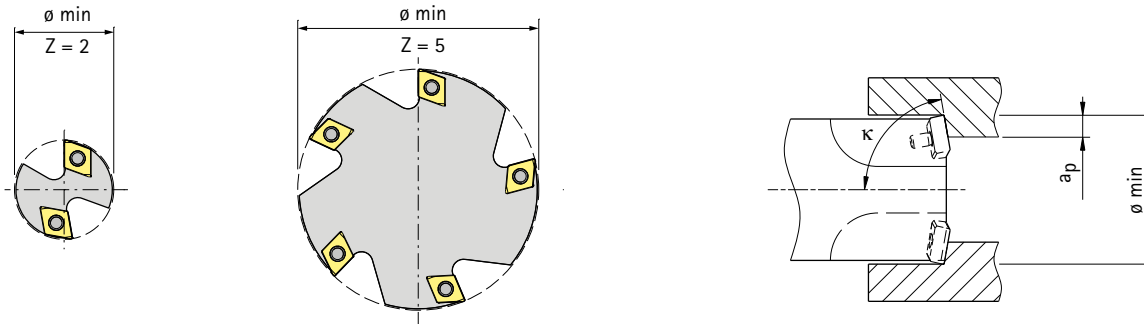

Taglienti di barenatura tangenziali senza arrotondamento

Forma inserto	Dimensione inserto			Numeri di denti	Nota
	0603/0604	09T3/0905	1204/1206		
C (80°)	Diametro minimo di barenatura con κ 80° e 90°				Indicato per fori passanti e spallamento retto
	28	41	54	1	
	28	41	54	2	
	30	41	54	3	
	40	56	64	4	
	59	84	94	5	

Taglienti di barenatura tangenziali con arrotondamento

Forma inserto	Dimensione inserto			Numeri di denti	Nota
	0604	0905	1206		
C (80°)	Diametro minimo di barenatura con κ 80° e 90°				Indicato per fori passanti e spallamento retto
	40	65	78	1	
	40	65	78	2	
	40	65	78	3	
	41	65	78	4	
	64	86	102	5	

Taglienti di barenatura tangenziali con e senza arrotondamento

Forma inserto	Dimensione inserto			Numeri di denti	Nota
	0604	0905	1206		
F (70°)	Diametro minimo di barenatura con κ 80° e 90°				Indicato per fori passanti e spallamento retto
	22	30	40	1	
	22	30	40	2	
	31	43	53	3	
	42	56	67	4	
	64	83	99	5	

Risoluzione dei problemi

Forme di usura su inserti a fissaggio meccanico

Forma di usura

Usura delle superfici libere

tangenziale



radiale

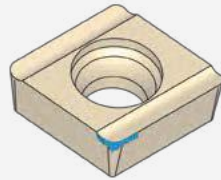

Usura del cratere

tangenziale



radiale

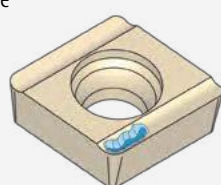

Usura della tacca

tangenziale

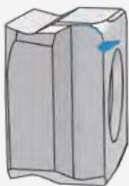

radiale

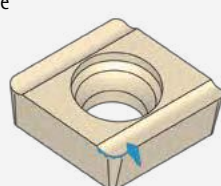

Tagliente di riporto

tangenziale



radiale

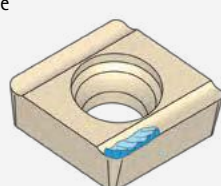

Difetti macroscopici

tangenziale



radiale

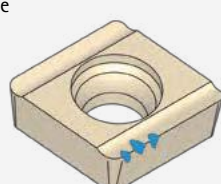

Rottura del tagliente

tangenziale



radiale

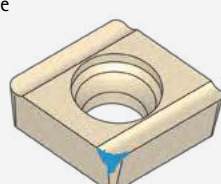

Misure risolutive

- Ridurre la velocità di taglio
- Scegliere un tipo di materiale da taglio con una maggiore resistenza all'usura

- Ridurre l'avanzamento
- Ridurre la velocità di taglio
- Scegliere un tipo di materiale da taglio con una maggiore resistenza all'usura
- Utilizzare del refrigerante

- Ridurre la velocità di taglio
- Selezionare un angolo di regolazione minore
- Ridurre l'avanzamento

- Aumentare la velocità di taglio
- Aumentare l'avanzamento
- Scegliere una geometria a taglio facile (taglienti affilati)

- Aumentare la velocità di taglio
- Ridurre l'avanzamento
- Scegliere un tipo di metallo duro più tenace
- Scegliere una geometria più forte
- Migliorare la stabilità (ad esempio utensile corto)
- Raffreddamento, continuato o a secco (evitare gli shock termici)

- Ridurre l'avanzamento
- Ridurre la profondità di passata assiale
- Scegliere una geometria dell'inserto a fissaggio meccanico più forte
- Scegliere un tipo di metallo duro più tenace
- Scegliere un inserto con uno spessore maggiore

Guida pratica - Risoluzione dei problemi in barenatura

Il foro diventa troppo grande	Il foro diventa troppo piccolo	Il foro diventa conico	Cattiva qualità della superficie nel foro
<p>Causa?</p> <ul style="list-style-type: none"> - Diametro utensile eventualmente troppo grande - Velocità di taglio troppo elevata - Avanzamento troppo elevato - Errore di concentricità troppo grande - Imbocco irregolare - Lubrificante non idoneo 	<p>Causa?</p> <ul style="list-style-type: none"> - Utensile usurato - Velocità di taglio troppo bassa - Avanzamento troppo basso - Materiale duttile, si restringe dopo la lavorazione - Sovrametallo troppo esiguo 	<p>Causa?</p> <ul style="list-style-type: none"> - Errore di concentricità troppo grande - Imbocco non ok - Lavorazione preliminare non ok 	<p>Causa?</p> <ul style="list-style-type: none"> - Lubrificante non idoneo - Depositi sul tagliente - Utensile smussato, eventuali danni macroscopici sul tagliente - Cattiva asportazione dei trucioli - Sbilanciamento residuo troppo grande
			

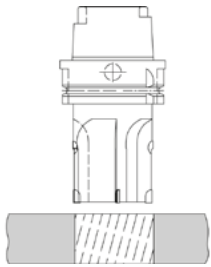
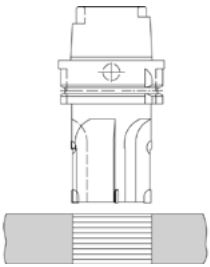
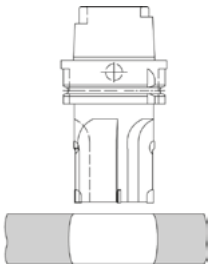
Il foro presenta intaccature dovute a vibrazioni	Il foro presenta segni dovuti all'avanzamento	Il foro diventa bombato
<p>Causa?</p> <ul style="list-style-type: none"> - Depositi sul tagliente - Utensile smussato - Lubrificante non idoneo - Errore di concentricità troppo grande - Sbilanciamento residuo troppo grande - Serraggio non ok 	<p>Causa?</p> <ul style="list-style-type: none"> - Utensile smussato, eventuali danni macroscopici sul tagliente - Depositi sul tagliente - Lubrificante non idoneo 	<p>Causa?</p> <ul style="list-style-type: none"> - Utensile non serrato correttamente
		



Simboli

Foratura		Foratura		Foratura pilota		Foratura a gradino		Foratura profonda
		Foratura-alesatura H7		Lavorazione ad alto avanzamento HFC		Lavorazione ad alta velocità HSC		Foratura a pacco
		Foratura trasversale		Ingresso inclinato del foro		Uscita inclinata del foro		Fondo di foratura piano 180°
		Foro da maschiare		Foro pilota		Massima tolleranza di foratura raggiungibile $\geq IT$		Serie selezionata in H7
		Tolleranza diametro di affilatura utensile Grind		Profondità di foratura massima 3xD		Adduzione del refrigerante		Attacco CFS
		Con inserto a fissaggio meccanico		Innesto QTS		Attacco TTS-100		Attacco TTS-300
		Forma del codolo HA secondo DIN HA DIN 6535		Forma del codolo HB secondo DIN HB DIN 6535		Forma del codolo HE secondo DIN HE DIN 6535		

Alesatura e barenatura di precisione		Foro passante		Foro cieco		Sistema di serraggio assiale HFS		Sistema di serraggio radiale HFS
		Serie selezionata in H7 H7		Massima tolleranza di foratura raggiungibile $\geq IT$ IT7		Tolleranza diametro di affilatura utensile Grind		Alesatore a un tagliente
		Inserto a fissaggio meccanico WP WP		Adduzione del refrigerante		Attacco HFS		Attacco modulo
		Attacco HSK-A HSK-A		Attacco codolo conico Morse (MK) MK		Codolo cilindrico HA secondo DIN HA DIN 6535		Forma del codolo HE secondo DIN HE DIN 6535
		Codolo cilindrico con superficie di serraggio						

Svasatura		Utensili di svasatura secondo DIN DIN 335 C		Svasatura 90° 90°
------------------	--	---	--	-----------------------------

Configurazione		Prodotto con caratteristiche configurabili CONFIG
-----------------------	--	---

Simboli

Classe di prodotto



Basic Line:
utensili universali, vasto campo di applicazione, bassi costi di acquisto



Performance Line:
utensili ad alte prestazioni, vasto campo di applicazione, elevata produttività nella produzione di serie



Expert Line:
utensili specifici per le applicazioni selezionate, massima precisione e massima produttività

Idoneità del materiale



 Particolarmente indicato

 Applicabile in particolari condizioni

Es. Tabella di idoneità standard del materiale

P	1	2	3	4	5	6	M	1	2	3	K	1	2	3	N	1	2	3	4	S	1	2	3	4	5	H	1	2	3	
	■	■	■	■			■				■	■			■						■									

Es. Tabella di idoneità del materiale per materiali non ferrosi e leggeri

N	1.1	1.2	1.3	1.4	2.1	2.2	2.3	3.1	4.1	4.2	4.3	G	1.1	1.2	1.3	2.1	3.1	4.1	4.2	5.1	5.2	5.3	
										■		■				■			■	■			

Gruppi di materiale MAPAL

Gruppo di materiale		Materiale	Resistenza/durezza [N/mm ²] [HRC]	Materiali lavorati frequentemente
P	P1	P1.1 Acciai da costruzione, automatici, da cementazione e da bonifica, non legati	< 700 N/mm ²	1.0122 (S235/St 37), 1.0401 (C15), 1.0503 (C45), 1.0570 (S355/St 52), 1.1213 (Cf53)
		P1.2 Acciai da costruzione, automatici, da cementazione e da bonifica, non legati	< 1200 N/mm ²	1.1249 (Cf70)
	P2	P2.1 Acciai da nitrurazione, da cementazione e da bonifica, legati	< 900 N/mm ²	1.7131 (16MnCr5)
		P2.2 Acciai da nitrurazione, da cementazione e da bonifica, legati	< 1400 N/mm ²	1.7227 (42CrMoS4)
	P3	P3.1 Acciai per utensili, per cuscinetti volventi, armonici e per lavorazioni veloci*	< 800 N/mm ²	1.2343 (X37CrMoV5-1), 1.2762 (75CrMoNiW6-7)
		P3.2 Acciai per utensili, per cuscinetti volventi, armonici e per lavorazioni veloci*	< 1000 N/mm ²	1.2367 (X38CrMoV5-3), 1.2713 (55NiCrMoV6)
		P3.3 Acciai per utensili, per cuscinetti volventi, armonici e per lavorazioni veloci*	< 1500 N/mm ²	1.2379 (X153CrMoV12), 1.2738 (40CrMnNiMo8-6-4)
	P4	P4.1 Acciai inossidabili, ferritici e martensitici		1.4510 (X3CrTi17), 1.4589 (X5CrNiMoTi15-2)
P5	P5.1 Acciaio fuso		1.7231 (G42CrMo4)	
P6	P6.1 Acciaio fuso, ferritico e martensitico			
M	M1	M1.1 Acciai inossidabili, austenitici	< 700 N/mm ²	1.4301 (V2A), 1.4571 (V4A)
		M1.2 Acciai inossidabili, ferritici/austenitici (Duplex)	< 1000 N/mm ²	1.4362 (Alloy 2304), 1.4501, 1.4662 (LDX 2404)
	M2	M2.1 Acciaio fuso inossidabile, austenitico	< 700 N/mm ²	
	M3	M3.1 Acciaio fuso inossidabile, ferritico/austenitico (Duplex)	< 1000 N/mm ²	
K	K1	K1.1 Ghisa con grafite lamellare (ghisa grigia), GJL	< 300 N/mm ²	GJL-250 (GG-25), GJL-260 (GG-26 Cr)
		K2.1 Ghisa con grafite sferoidale, GJS	< 500 N/mm ²	GJS-400 (GGG-40), GJS-450 (GGG-45)
	K2	K2.2 Ghisa con grafite sferoidale, GJS	≤ 800 N/mm ²	GJS-600 (GGG-60), GJS-800-2 (GGG-80), GJS-800-8 (ADI 800)
		K2.3 Ghisa con grafite sferoidale, GJS	> 800 N/mm ²	GJS-900-2 (GGG-90), GJS-1000-5 (ADI 1000), GJS-1200-2 (ADI 1200), GJS-1400-1 (ADI 1400)
	K3	K3.1 Ghisa con grafite vermicolare, GJV; acciaio fuso malleabile, GJM	< 500 N/mm ²	GJV-300, GJV-400, GJMW-400-5 (GTW-40)
		K3.2 Ghisa con grafite vermicolare, GJV; acciaio fuso malleabile, GJM	> 500 N/mm ²	GJV-500, GJV-700
N	N1	N1.1 Alluminio, non legato e legato < 3% Si		Alloy 2024, Alloy 7075, Al99
		N1.2 Alluminio, legato ≤ 7% Si		AlSi7
		N1.3 Alluminio, legato > 7-12% Si		AlSi9, AlSi9Cu
		N1.4 Alluminio, legato > 12% Si		AlSi12, AlSi17
	N2	N2.1 Rame, non legato e bassolegato	< 300 N/mm ²	SE-Cu
		N2.2 Rame, legato	> 300 N/mm ²	CuSn6
	N3	N2.3 Ottone, bronzo, ghisa rossa	< 1200 N/mm ²	CuZn33, CuAl9Mn3
		N3.1 Grafite, > 8 µm		
	N3	N3.2 Grafite, ≤ 8 µm		
		N4.1 Plastica, thermoplast		PA, PE, PC, PS, PVC, PP, PTFE, POM, PMMA
N4	N4.2 Plastica, duroplast		PU, PF, EP, UP, VE, CR	
	N4.3 Plastica, materiali espansi		EPS, PUR, PVC-E, PS-E, PP-E	
C	C1	C1.1 Matrice plastica, rinforzata con fibre di aramide (AFK)		Nomex, Kevlar, Twaron, KOREX
		C1.2 Matrice plastica (duroplastica), CFK/GFK		IMS, HTA
		C1.3 Matrice plastica (termoplastica), CFK/GFK		GMT-PP, PEEK
	C2	C2.1 Matrice in carbonio, rinforzata con fibre di carbonio (CFC)		CF222, CF225, CF226, CF227, CF260
	C3	C3.1 Matrice metallica (MMC)		CeramTec AO-403 (AlSi9MgMn-Al2O3), Al/Cu/Mg-SiO2/Al2O3/AlN/TiC/SiC/BN/TiB2
	C4	C4.1 Struttura a sandwich, nucleo a nido d'ape (Honeycomb)		
		C4.2 Struttura a sandwich, nucleo in materiale espanso		PLASCORE PAMG-XR1 5052, PCGA-XR1 3003, PAMG-XR1 5056, Micro-Cell (core made of Alloy 5052/5056)
	C5	C5.1 Composito stratificato (stack), composito non metallico/non ferroso		CFK-Aluminium, IMS/HTA + Alloy 2024/6061/7075
		C5.2 Composito stratificato (stack), composito non metallico/metallico		CFK-Titan, IMS/HTA + TiAl6V4/AMS4905
		C5.3 Composito stratificato (stack), composito non metallico/non metallico		CFK-CFK
		C5.4 Composito stratificato (stack), composito non ferroso/non ferroso		Alluminio/Alluminio
		C5.5 Composito stratificato (stack), composito non ferroso/metallico		Alluminio/Titanio
C5.6 Composito stratificato (stack), composito metallico/metallico			Titanio/Inox	
S	S1	S1.1 Titanio, leghe di titanio	< 400 N/mm ²	
		S2.1 Titanio, leghe di titanio	< 1200 N/mm ²	TiAl6V4
	S2	S2.2 Titanio, leghe di titanio	> 1200 N/mm ²	
		S3.1 Nichel, non legato e legato	< 900 N/mm ²	1.3912 (Invar, Ni36)
	S3	S3.2 Nichel, non legato e legato	> 900 N/mm ²	
S4	S4.1 Superlega resistente ad alte temperature a base di Ni, Co e Fe		Hardox, Hastelloy, Incoloy, Inconel, NIMONIC, Stellite, Waspaloy	
S5	S5.1 Leghe di tungsteno e molibdeno			
H	H1	H1.1 Acciaio temprato/acciaio fuso	< 44 HRC	1.2738 HH, 1.2085, Toolox 33, Toolox 44
		H1.2 Acciaio temprato/acciaio fuso	< 55 HRC	1.2343, 1.2311, 1.2312, 1.2714, 1.2083, 1.2738
	H2	H2.1 Acciaio temprato/acciaio fuso	< 60 HRC	1.1730, 1.2379, 1.2358, 1.2767, 1.4112, ASP 2012
		H2.2 Acciaio temprato/acciaio fuso	< 65 HRC	1.2379, 1.2363, 1.2436, 1.2842, 2005, ASP 23
	H3	H2.3 Acciaio temprato/acciaio fuso	< 68 HRC	ASP 2017, ASP 2023, Vanadis 30, Vanadis 60
H3	H3.1 Ghisa resistente all'usura/ghisa temperata, GJN			

* Qualora la somma dei componenti di lega Cr, Mo, Ni, V, W equivalesse a > 8%, selezionare il gruppo di truciatura MAPAL immediatamente superiore.



Scoprite subito le soluzioni complete di utensili e servizi che Vi daranno grandi vantaggi:

LAVORAZIONE DI FORI

ALESATURA | BARENATURA DI PRECISIONE

FORATURA | BARENATURA | SVASATURA

FRESATURA

SISTEMI DI SERRAGGIO

TORNITURA

UTENSILI A MOVIMENTAZIONE INTERNA

PRESETTAGGIO | MISURAZIONE | STOCCAGGIO

SERVIZI